



This Service Information bulletin supersedes SI B11 04 04 dated October 2004.

PERFORM THE PROCEDURE OUTLINED IN THIS SERVICE INFORMATION ON ALL AFFECTED VEHICLES THE NEXT TIME THEY ARE IN THE SHOP FOR MAINTENANCE OR REPAIRS.

**NEW** designates changes to this revision

#### SUBJECT

Service Action: E46 M3 S54 Connecting Rod Bearings Replacement

#### MODEL

E46 M3 coupe/convertible with S54B32 engine produced from 02/12/2001 up to 05/22/2003

#### SITUATION

The connecting rod bearings installed in M3 coupe/convertible vehicles produced from February 2001 through May 2003 were not manufactured to BMW quality standards. As a result, the connecting rod bearings are susceptible to overheating and subsequent premature failure if vehicles are driven at higher engine speeds over an extended timeframe. This condition will cause a total engine failure.

A Service Action will be conducted on those vehicles to replace the connecting rod bearings. Additionally, the engine control module will be programmed with the latest software. Customers will be mailed letters notifying them of the Service Action shortly (copy of letters and Q&A list are attached).

The M3 vehicles produced from October 2001 through February 2002, which already had the Connecting Rod Bearings/Oil Pump Campaign 356 (SI B 11 02 03) previously performed, are also affected by this Service Action.

**Important note:** All M3 coupe/convertible vehicles equipped with SMG transmission affected by this Service Action Campaign are also in the range of the Service Action 423: Reprogramming of the SMG Control Module with DIS CD 39 (SI B23 05 04). Make sure that both Service Actions are performed during the same service visit.

To minimize the customer inconvenience caused by this Service Action, you may pick-up (and deliver after repair) the affected vehicle from customer's home and provide appropriate alternative transportation.

Customers will be impressed when you return their cars cleaned inside and out and with a full tank of gas. Reimbursement information for the vehicle fueling and valet costs may be found in the Warranty portion of this bulletin.

#### AFFECTED VEHICLES

This Service Action involves E46 M3 coupe/convertible vehicles with S54B32 engines which were produced from February 12, 2001 up to May 22, 2003.

In order to determine if a specific vehicle is affected by this Service Action, it will be necessary to utilize the "Service Menu" of the DCS (Dealer Communication System). Based on the response of the system, either proceed with the corrective action or take no further action.

The Chassis Number Ranges listed below are only for informational purposes and are not to be considered as the only deciding factor.

Model	Chassis Number Range
M3 convertible	EX20040 - EX24999 PK00000 – PK03913
M3 coupe	JR10051 – JR23641

#### CORRECTION

In the affected vehicles, replace the connecting rod bearings. Reprogram DME control module.

Following completion of this Service Action, the following engine break-in instructions must be observed by customers; for the first 1,200 miles engine speed should not exceed 5,500 rpm or road speed should not exceed 105 mph.

Engine oil service is not required after the completion of engine break-in period.

**PROCEDURE**

Detailed Service Action repair instructions can be found on the CD ROM "SIP S54 Connecting Rod Bearings Replacement", which was included in the Oil Pump Kit with Connecting Rod Bearings (p/n 11 41 0 301 359) used for the previous M3 Engine Campaign 356 (SI B11 02 03). It takes approximately 15 minutes to review the content of the CD.

**FAMILIARIZE YOURSELF WITH THE CONTENT OF THE INSTRUCTION CD PRIOR TO STARTING THE REPAIR. ALL STEPS MUST BE CARRIED OUT AS PRESENTED.**

The connecting rod bearings will be replaced without removing the engine from the vehicle. In order to remove the oil pan, the complete front axle carrier must be detached from the body and lowered by approximately 100 mm.

Since the front strut top mounts are not being disturbed in the process, there is no need to perform a wheel alignment check after the repair is completed.

All parts required to perform this Service Action are included in the Connecting Rod Bearings Kit (p/n 11 41 0 395 192), with the exception of the Oil Pan Gasket (p/n 11 13 1 437 237), the M10 x 1.25 Connecting Rod Bolts (p/n 11 24 7 834 310) for vehicles from 12/13/2002 production and the Oil Sump Cover Gasket (p/n 11 13 7 834 886) for vehicles from 04/2003 production, which should be ordered separately.

1. Remove front wheels.
2. Remove intake filter housing. For removal instruction refer to RA 13 71 000 found in BMW TIS.

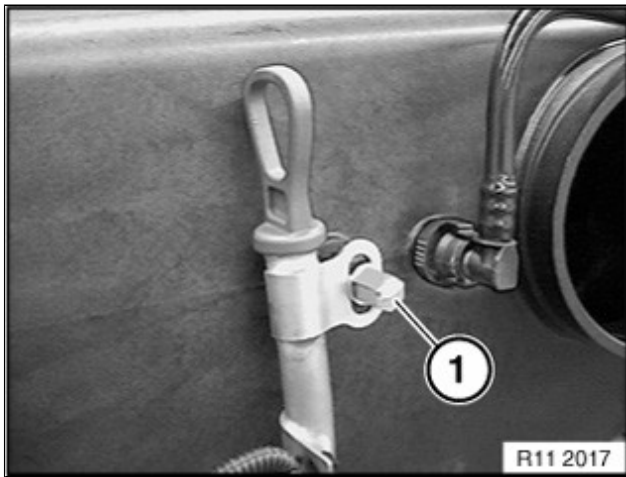

3. Detach guide tube (1) for oil dipstick from the intake manifold.

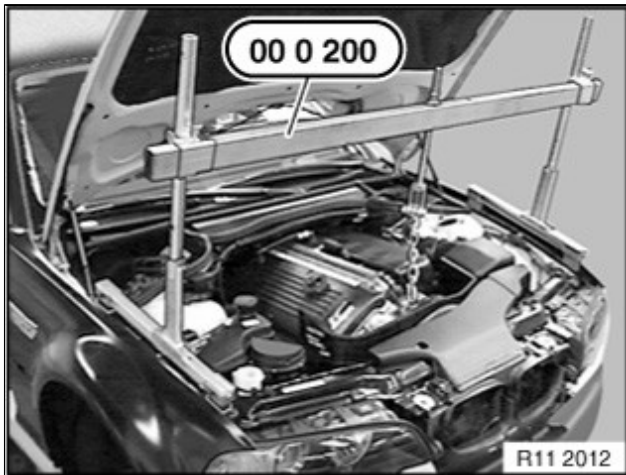

4. Install special tool (p/n 88 88 6 00 0 200 "engine brace") in engine compartment in order to support engine during the repair. For installation instructions refer to RA 11 13 000.

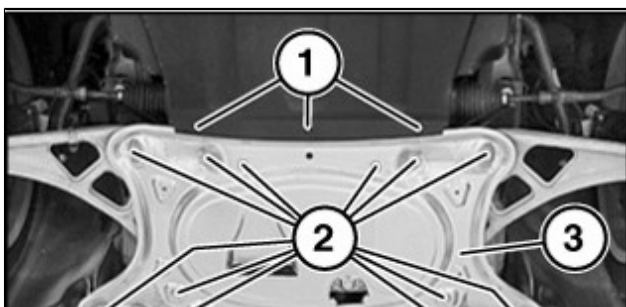

5. Remove engine splashguard. Remove thrust (3) plate on front axle support. For removal instructions refer to RA 51 71 374.

6. Drain engine oil.

**Important:** When reinstalling thrust plate, use a set of new M10 x 30 x 1.5 screws provided in the parts kit. Then, the



reinforcement plate screws must be tightened in two stages:  
 - first, torque with 59 Nm  
 - then, angle torque to 90°  
 Using Torque Angle Measuring Tool (p/n 90 88 6 009 120 available through the Automatic Tools Shipment Program)

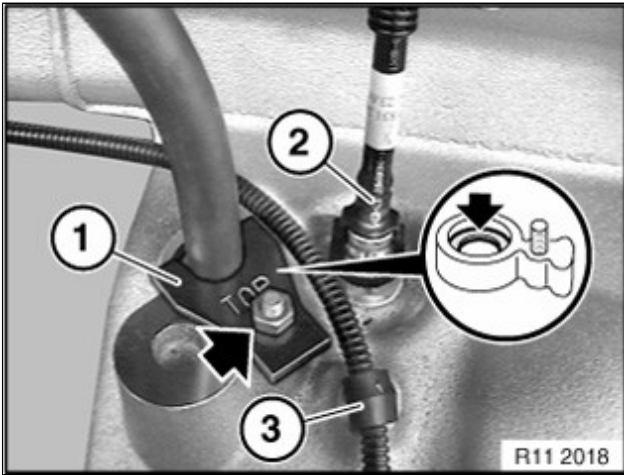

7. Remove dipstick holder (1) from the oil sump, and remove dipstick.

8. Detach oil condensate return hose (2).

**Important:** When reinstalling the oil dipstick, replace the O-ring (as indicated by black arrow) included in the parts kit.

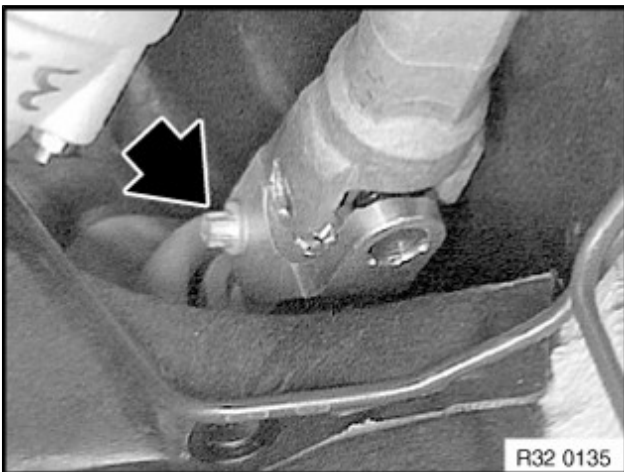

9. Detach steering spindle from the steering rack by removing clamping screw.

**Important:** Use the new clamping screw M8 x 33 (provided in the parts kit) when reinstalling steering spindle. Tightening torque should be 22 Nm.

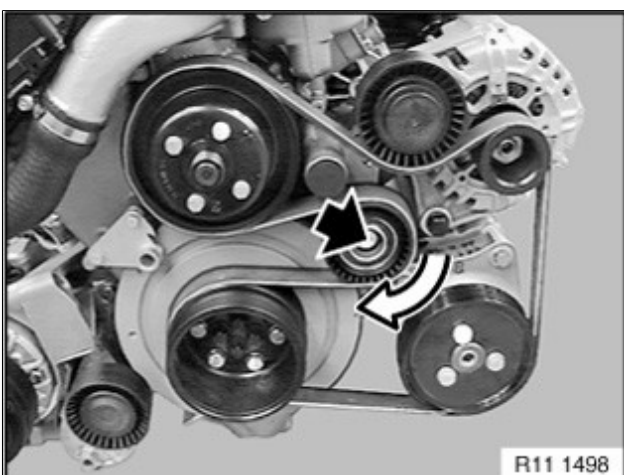

10. Detach oil lines from the power steering pump bracket.

11. Remove drive belt from the power steering pump belt pulley. In order to do this, remove the plastic cover from the belt tensioner pulley. Using a 6 mm Allen key, compress tensioner by rotating it clockwise until p/s belt can be removed.

12. Remove power steering pump without disconnecting power steering lines. Secure steering pump to the body by using plastic wire ties.

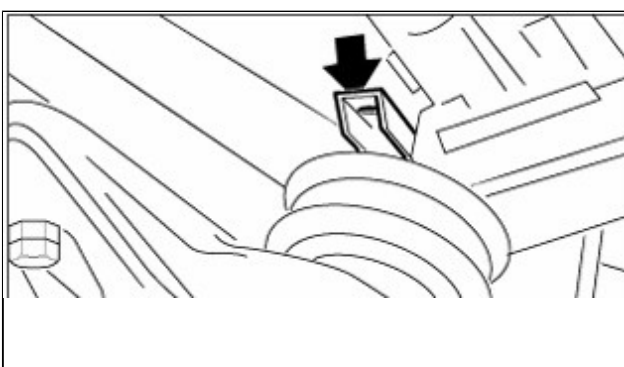

13. Unfasten two nuts at the bottom of the engine mounts.

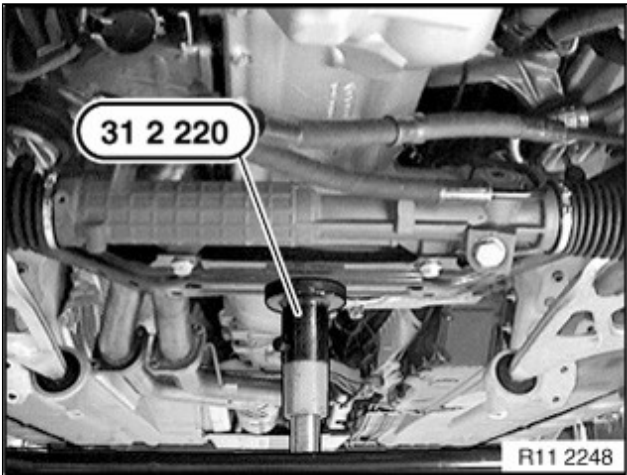

14. Release retaining brackets for front stabilizer bar.

15. Detach brackets for left and right wishbone lower control arms.

16. Support front axle carrier with a suitable hydraulic support jack (e.g. Universal Hydraulic Stand p/n 88 88 6 00 2 030).

17. Release 4 bolts securing front axle carrier and lower the whole axle by approximately 100 mm.

**Important:** There is no need to detach the steering rack from the front axle during this procedure.

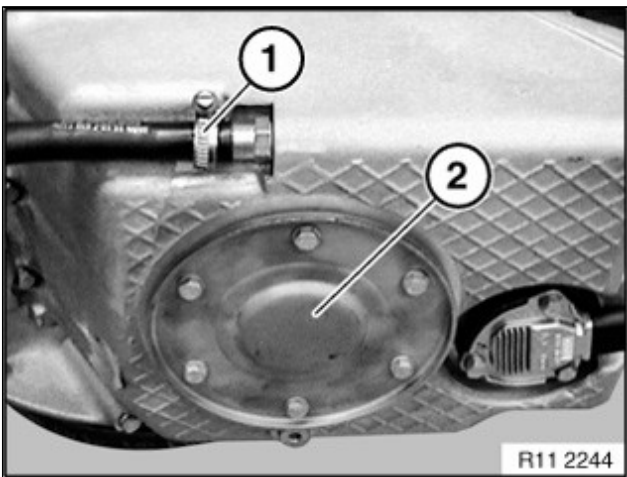

18. Detach return hose (1) from oil sump.

19. Remove cover (2) from oil sump.

20. Disconnect oil level sensor connector.

**Important:** Replace gasket for sump cover (2) when reinstalling oil sump (gasket is provided in the parts kit). For vehicles up to 04/2003 production, Oil Sump Cover Gasket (p/n 11 13 7 832 023) is provided in the parts kit. For vehicles from 04/2003, the new design Oil Sump Cover Gasket (p/n 11 13 7 834 886) has to be ordered separately.

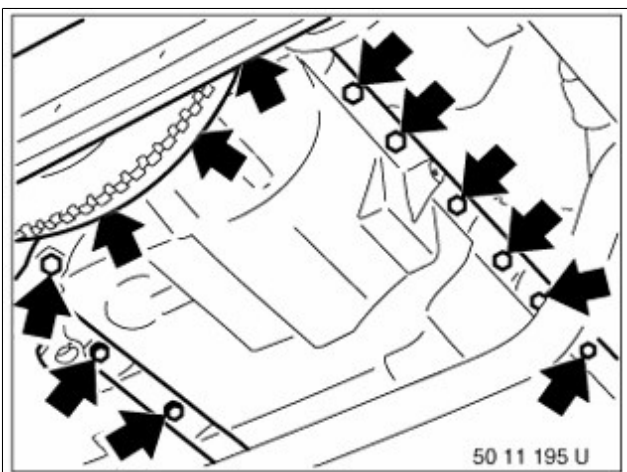

21. Unfasten oil sump screws and carefully remove oil pan.

**Important:** Three screws on the left side of the oil pan (near the oil condensate return hose) are 5 mm longer than the rest of them. On SMG transmission equipped vehicles, if necessary, disconnect bracket for engine oil lines to ensure sufficient clearance for oil sump movement. When reinstalling, use new Oil Pan Gasket (p/n 11 13 1 437 237 ordered separately). Also, apply a small amount (bead approximately 3 mm wide and 2 mm high) of HYLOMAR Sealing Compound (p/n 81 22 9 400 339) in areas around timing cover/engine block/bell housing joints. Detailed procedure can be found in the instructional CD. Then, torque down oil pan screws (M6) to 10 Nm when reinstalling.

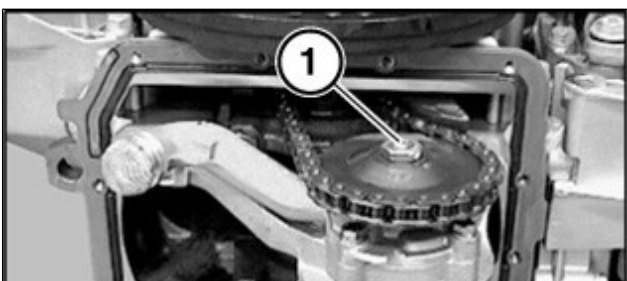

22. Using M17 mm socket remove oil pump sprocket nut (1).



Important: Left-hand threads (turn clockwise to loosen).



23. **Important:** To reduce tension exerted by the oil pump chain when loosening the sprocket nut, remove all slack existing in the chain. It can be done by tightening chain around the sprocket (as shown on the illustration) with approx. 7" of soft wire (e.g., from a wire hanger). This will protect plastic tensioner from possible damage while loosening the sprocket nut.

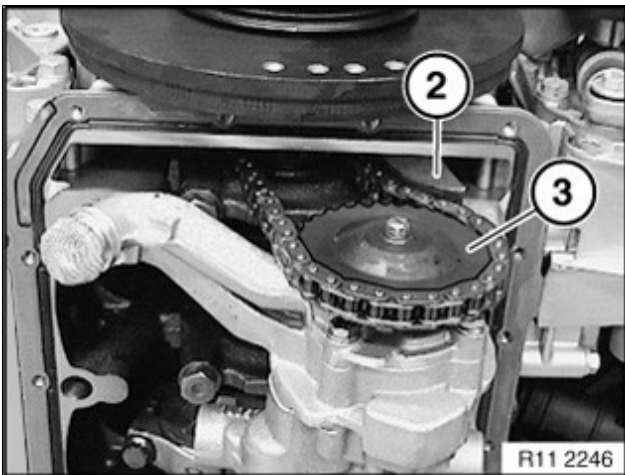

24. Press back the chain tensioner (2). Detach sprocket wheel (3) from oil pump shaft.

**Important:** When reinstalling, align teeth of the sprocket wheel and oil pump shaft. Torque down sprocket nut to 25 Nm.

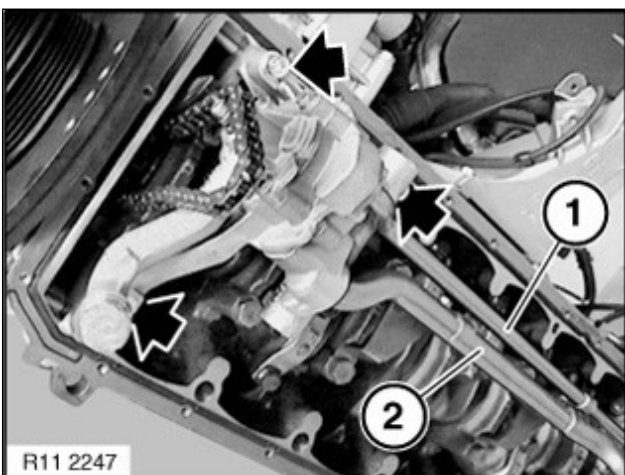

25. Remove oil pump return pipe (1) and suction pipe (2). Remove oil pump.



26. Remove two fastening screws (1) for oil cooler. Detach



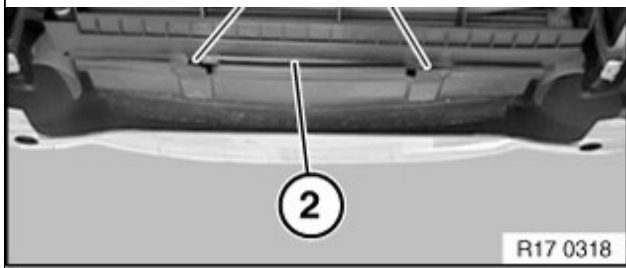

oil cooler (2) from the bottom of radiator without disconnecting oil hoses. Secure oil cooler to the body by means of plastic wire ties.

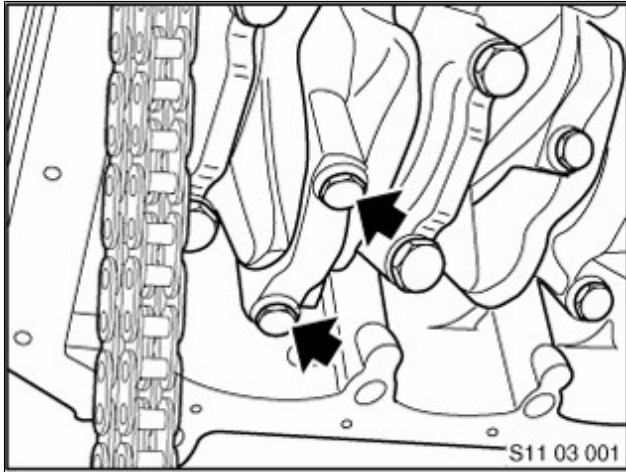

27. Connecting rod bearings bolts can be accessed from the bottom, in the following sequence: cylinders 1 and 6, cylinders 3 and 4, finally cylinders 2 and 5, when rotating crankshaft in clockwise direction. Using a special tool (p/n 90 88 6 115 100) at the crankshaft vibration damper pulley, turn crankshaft clockwise until number 1 cylinder connecting rod bolts are accessible.

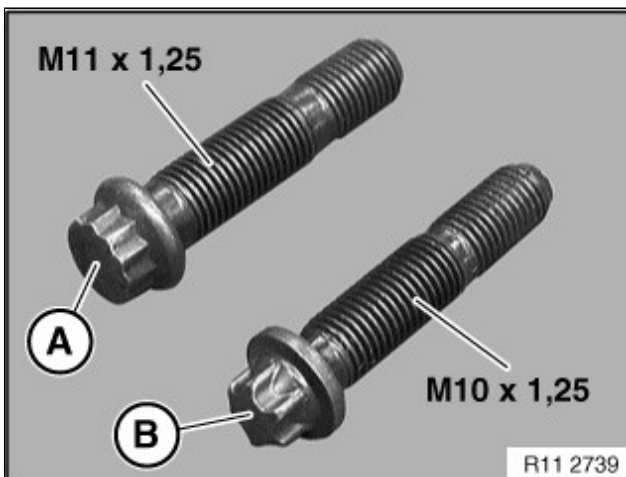

28. Remove connecting rod bolts (use M12 mm, 12-point socket on vehicles with M11 x 1.25 bolts; or Torx E12 on vehicles equipped with M10 x 1.25).

**Important:** On vehicles produced up to 12/13/2002, the M11 x 1.25 connecting rod bolts (A) will be reused with the new bearings. It is essential to mark them and then reinstall them in the same order (e.g. bolt from the exhaust side must be reinstalled again on the exhaust side, etc). On vehicles produced from 12/13/2002, the new design M10 x 1.25 connecting rod bolts (B) have to be replaced with the new connecting rod bearings. The M10 x 1.25 bolts have to be ordered separately (p/n 11 24 7 834 310 – 12 bolts per vehicle).

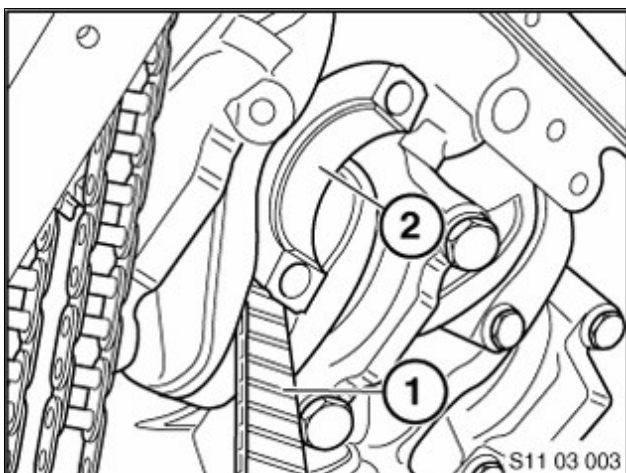

29. Cut off a strip (1) from a clean and fiber-free cardboard with approximate dimensions of 20 mm x 150 mm. Use such a cardboard strip to protect crankshaft bearing surface.

30. After removing connecting rod cap, gently push connecting rod upwards, and then after securing enough clearance from the crankshaft, slowly pull it down in order to remove the upper bearing shell (2).

**Important:** Do not use sharp tools to pry out the bearing shells out of the connecting rod or cap.

**Note:** If the removed connecting rod bearings exhibit signs of excessive wear (e.g.: exposed shiny, copper bedding on the inner surface; missing, sheared-off locking tabs; or deep, shiny grooves on the outer surface indicating "spinning"), then contact the Technical Hotline Drivetrain for further instructions.

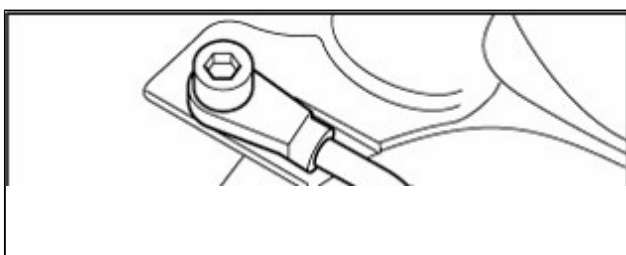

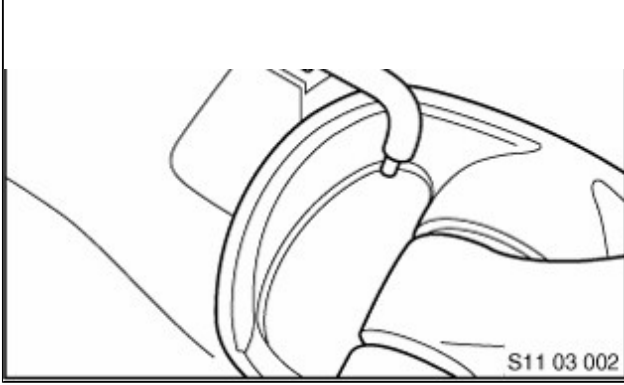

**Important:** When pulling down pistons for connecting rod bearing shell disassembly, make sure not to damage oil spray nozzles, which are located at the bottom side of the block (between crank bearing supports).

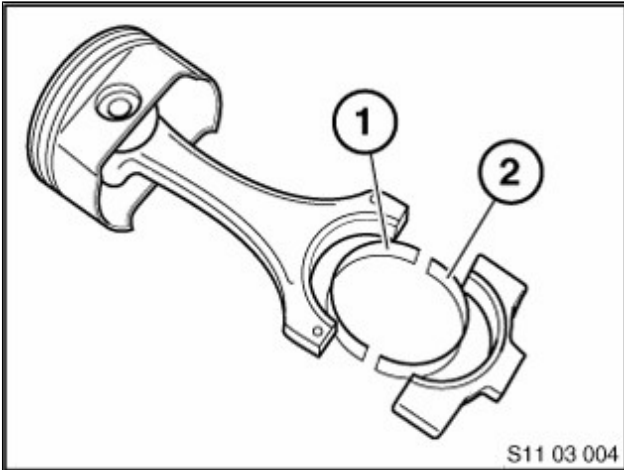

One classification of connecting rod bearings will be used in this Service Action. Connecting rod bearings are color-coded:

- Blue (1) for the connecting rod side
- Red (2) for the cap side.

**Important:** In order to ensure engine reliability, it is essential to install bearing shells in the order specified above.

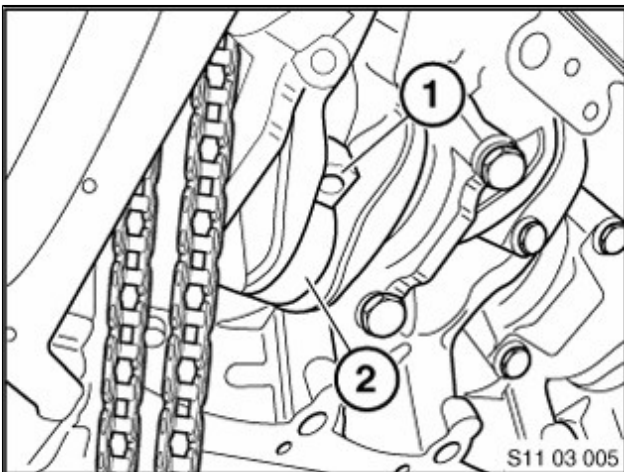

31. Clean connecting rod bearing surface with fiber-free cloth, then install "blue" bearing shell and moisten it with clean 10W-60 engine oil.

32. Then, carefully push the connecting rod (1) upwards and over the crankshaft journal (2), making sure that crankshaft surface is not scratched in the process.

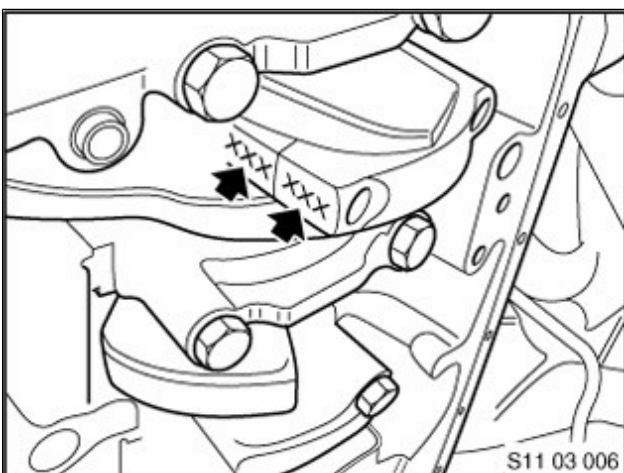

33. Install "red" bearing shell in the corresponding connecting rod cap and moisten it with clean 10W-60 engine oil.

34. Install connecting rod cap in the proper position, with matching serial numbers stamped on cap and rod as shown on the illustration.

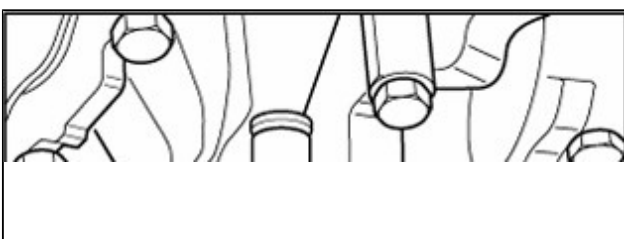

35. On vehicles produced up to 12/13/2002, install the original M11 x 1.25 connecting rod bolts in the same positions as when removed. On vehicles produced from 12/13/2002, install new set of M10 x 1.25 Connecting

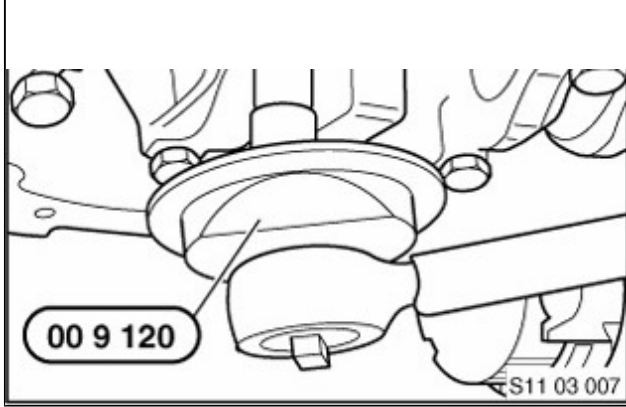

Rod Bolts (p/n 11 24 7 834 310).

36. With help of a second person, torque the connecting rod bolts in the following sequence:

Vehicles with M11 x 1.25 conrod bolts;

- settling torque: 5 Nm
- initial torque: 30 Nm
- angle torque to 70°, in one single stroke.

Use the Torque Angle Tool (p/n 90 88 6 00 9 120 available through the Automatic Parts Shipment Program).

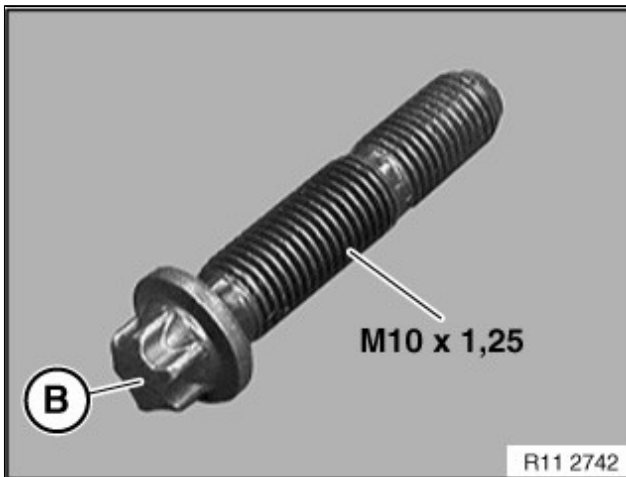

37. On vehicles from 12/12/2002 production, the M10 x 1.25 con rod bolts must be tighten at least **three** times in order to reach its maximum tensile strength.

**Important:** Not adhering to the tightening specifications detailed below, will result in serious engine damage.

Vehicles with M10x1.25 con rod bolts;

First tightening of conrod bolts:

- settling torque: 5 Nm
- initial torque: 30 Nm
- angle torque to 105°, in one single stroke.

Use the Torque Angle Tool (p/n 90 88 6 00 9 120 available through the Automatic Parts Shipment Program). Then, release the torque by backing off conrod bolts by approximately one turn and then retighten them again.

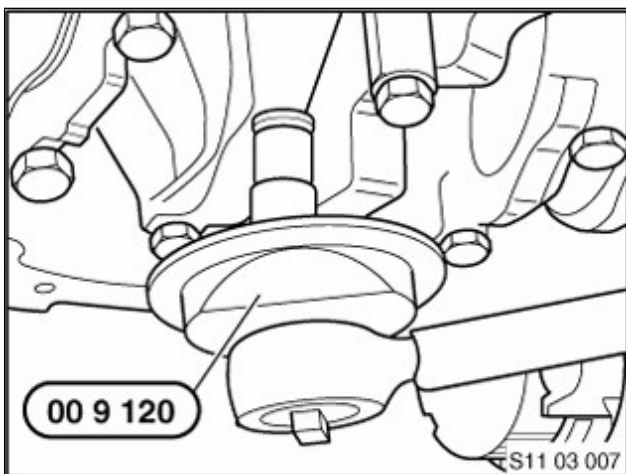

Secondtightening of conrod bolts:

- settling torque: 5 Nm
- initial torque: 30 Nm
- angle torque to 105°, in one single stroke.

Then, back off conrod bolts again by approximately one turn and finally retighten them again.

Third tightening of conrod bolts:

- settling torque: 5 Nm
- initial torque: 30 Nm
- angle torque to 105°, in one single stroke.

38. Reinstall all previously removed components.

**NEW** 39. Replace oil filter and refill engine with 6.5 liters of fresh 10W-60 oil (Castrol Formula RS, or Castrol TWS Motorsport BMW p/n 07 51 0 009 420).

**NEW Note:** With the removal of oil pan, some minor quantity of oil (which otherwise would stay inside pan during regular oil/filter service) is disposed during draining and cleaning of oil pan from inside. To compensate for this loss, the additional 1.0 liter of oil (to the total of 6.5 liters) was allocated for this Service Action repair.

**Important:** S54B32 engine oil refill capacity used during **scheduled oil service** (with oil filter replaced) is **5.5 liters (5.8 quarts)** of Castrol 10W-60 Synthetic Oil (p/n 07 51 0 009 420). For the proper procedure of checking oil level, refer to [SI B11 03 03](#) (04/2003).

Engine Oil Level Checking Procedure:

1. Park the vehicle on a level surface.
2. With engine warmed to its normal operating temperature (one yellow LED illuminated on the tachometer), allow it to idle for at least 15 seconds, then switch off.
3. After approximately 1 minute, pull the dipstick out and wipe it off with a clean lint-free cloth, paper towel, or similar material.



4. Carefully push the dipstick into the guide tube and pull it out again.
5. The oil level should be between the two marks on the dipstick.

**NEW** **Note:** With 6.5 liter of fresh oil, and when correctly checked, the oil level should be between the two marks on the dipstick. It is not necessary, nor recommended to bring oil level to the "max" mark on the dipstick. The oil volume between two marks on the dipstick corresponds to approximately 1.3 liters (1.4 quarts).

Do not fill beyond the upper mark on the dipstick. Excess oil will induce excessive oil consumption, and may damage the engine.

40. Reprogram DME control module using DISPlus/GT1 with CD 38.0 or higher.

To reprogram DME:

- Connect vehicle to the BMW approved battery charger.
- Connect DISplus/GT1 loaded with CD 38.0, or higher.
- Select: BMW Coding/Programming .
- Select: 5 Programming, then right arrow.
- Select: 3 DME Programming, then right arrow.
- Select: 2 Exchange control unit, then right arrow.
- Display appears: First determine and then program basic control unit , then right arrow.
- Select: 1 Determine basic control unit, then right arrow. Automatic determination is going to be performed.
- DME, is the faulty control unit still installed in the car? Select Yes
- Start automatic determination? Select Yes
- Display appears: Compare chassis number displayed with number in the car. Chassis number ..... Do numbers correspond? Select Yes
- Part number basic control unit ...../..... are displayed, then scroll down.
- Display appears: Followed part numbers (basic control unit) can likewise be used. A new program version is also programmed for these part numbers. Duration depends on control unit between 4 – 16 minutes, then scroll down.
- At this point vehicle data is stored in the tester for the automatic identification. Disregard screen prompt which refers to obtaining and installing a new basic control unit and scroll to the left.
- Select: 2 Program basic control module, then right arrow.
- Follow instruction: Chassis number, enter the last 7 characters of VIN. Is the number correct? Select Yes
- Disregard the next instruction: Install new basic control module, just go forward by pressing right arrow.
- Display will appear: There is new program version and new data version for this control unit. Depending on the control unit, programming may last between 4-16 minutes. First programming and then data are programmed. After programming, with diagnosis program, the fault memories have to be cleared. EWS alignment is automatically carried-out with reprogramming. The adaptation values must be cleared after programming, then right arrow.
- The next screen displays: The control module can be programmed X times, then right arrow.
- Follow the command: Please enter reading mileage.....Entry correct? Select: Yes
- Start automatic programming? Select: Yes
- When programming starts, the following message is displayed: MSS54 Program programming active. Voltage terminal 30.....

- After programming part is finished , the following message is displayed: MSS54 data programming active. Voltage terminal 30.....
- After successful programming, message is displayed: Programming completed.
- Next, follow-up screen instructions for EWS alignment and for clearing of adaptation values.

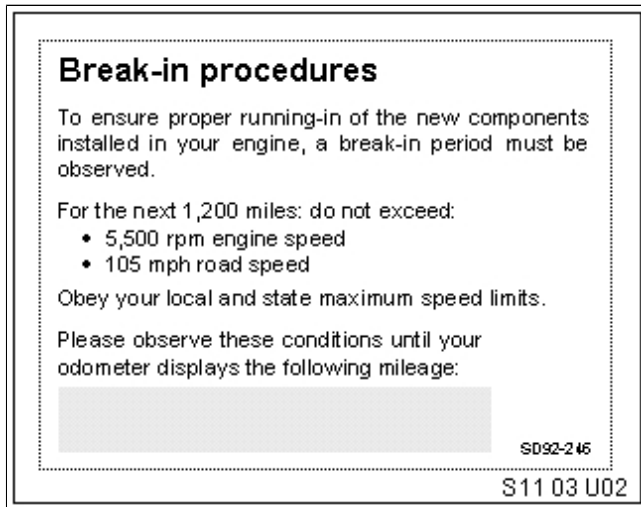

41. Obtain one "Break-in procedures" label (SD92-246). Using a ball-point pen, write the appropriate mileage (current mileage + 1,200 miles) on the label, and apply to the upper left corner of the windshield. Initial quantity (50 labels per center) has been shipped to every BMW Service Center. Additional quantities can be ordered online at BMW TIS.

#### PARTS INFORMATION

Part Number	Description	Quantity
11 41 0 395 192	S54 Connecting Rod Bearing Kit	1
11 13 1 437 237	Oil Pan Gasket	1
11 24 7 834 310	M10 x 1.25 Conrod Bolt (vehicles from 12/12/02)	12
07 51 0 009 420	10W-60 Castrol Motor Oil (liter)	<b>NEW</b> 6.5
11 13 7 834 886	Oil Sump Cover Gasket (vehicles from 04/2003)	1

Orders for the S54 Connecting Rod Bearing Kit (p/n 11 41 0 395 192) will be VIN specific. Orders may be placed as a VOR or stock order. The VIN is to be placed in the "comment/text" field. It is recommended that VIN not be used as the P.O. number. This will prevent using the VIN again for subsequent VIN specific orders. Only orders with a VIN will be released. All other orders will be cancelled.

#### LABEL INSTRUCTIONS

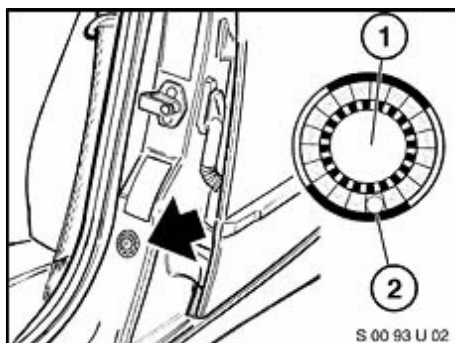

This Service Action has been assigned code number 422 After the vehicle has been checked, and corrected if necessary, obtain a label (SD92-267) and:

- @. emboss your BMW dealer warranty number in the middle of the label (1);
  - a. punch out code number 422(2) printed on the label and,
  - b. affix the label to the B pillar as shown.

If the vehicle already has a label from a previous Service Action/Recall Campaign, affix the new label next to the old one. Do not affix one label on top of another one because a number from an underlying label could appear in the punched-out hole of the new label.

#### WARRANTY INFORMATION

Reimbursement for this Service Action will be via Campaign Entry. Utilize the defect code for the open campaign identified in DCS. Each affected vehicle will only have one of the following defect codes "open". Claims will not be accepted if they are submitted using the incorrect defect code.

Defect Code            00 11 95 01 00

<b>Work Package #1:</b>	Replace set of connecting rod bearings and reprogram DME.	
Labor Operation:	00 55 057	
Labor Allowance:	69 FRU	
Parts Allowance:	11 41 0 395 192 – Connecting Rod Bearings Kit	Qty (1)
	11 13 1 437 237 – Oil Pan Gasket	Qty (1)
Sublet Allowance	<b>NEW</b> 6.5 liters of 10W-60 Castrol Motor Oil	\$65.06
Sublet Code:	4	
<b>Defect Code</b>	00 11 94 01 00	
<b>Work Package #1:</b>	Replace set of connecting rod bearings and reprogram DME on vehicles with M11 x 1.25 conrod bolts (up to 12/13/2002 production).	
Labor Operation:	00 55 056	
Labor Allowance:	69 FRU	
Parts Allowance:	11 41 0 395 192 – Connecting Rod Bearings Kit	Qty (1)
	11 13 1 437 237 – Oil Pan Gasket	Qty (1)
Sublet Allowance	<b>NEW</b> 6.5 liters of 10W-60 Castrol Motor Oil	\$65.06
Sublet Code:	4	
<b>Work Package #2:</b>	Replace set of connecting rod bearings and bolts and reprogram DME on vehicles with M10 x 1.25 bolts (from 12/13/2002 production).	
Labor Operation:	00 55 115	
Labor Allowance:	72 FRU	
Parts Allowance:	11 41 0 395 192 – Connecting Rod Bearings Kit	Qty (1)
	11 13 1 437 237 – Oil Pan Gasket	Qty (1)
	11 24 7 834 310 – M10 x 1.25 Conrod Bolt	Qty (12)
Sublet Allowance	<b>NEW</b> 6.5 liters of 10W-60 Castrol Motor Oil	\$65.06
Sublet Code:	4	
<b>Work Package #3:</b>	Replace set of connecting rod bearings and bolts and reprogram DME on vehicles with M10 x 1.25 bolts (from 04/2003 production).	
Labor Operation:	00 55 115	
Labor Allowance:	72 FRU	
Parts Allowance:	11 41 0 395 192 – Connecting Rod Bearings Kit	Qty (1)
	11 13 1 437 237 – Oil Pan Gasket	Qty (1)
	11 24 7 834 310 – M10 x 1.25 Conrod Bolt	Qty (12)
	11 13 7 834 886 – Oil Sump Cover Gasket	Qty (1)
Sublet Allowance	<b>NEW</b> 6.5 liters of 10W-60 Castrol Motor Oil	\$65.06
Sublet Code:	4	

As previously communicated to the owners of the affected vehicles, the warranty for internal engine oil lubricated parts is extended to 6 years, 100,000 miles, whichever comes first. This will be valid for the model year 2001, 2002 and 2003 S54 equipped vehicles, including 2001 and 2002 model year M roadster/coupe vehicles with S54 engines.

Please make sure the customers of these vehicles are aware of this warranty extension and coverage.

#### RE-FUELING COSTS

BMW of North America, LLC, will provide reimbursement to have the gas tank topped off once as required, for each vehicle affected by this Service Action.

Defect Code: 85 99 00 66 NA Refuel M3 when performing Service Action Code 422

Sublet: Actual gas cost to top off fuel tank

Sublet Code: 4

Please attach the gas purchase receipt to the repair order to document cost.

#### RENTAL VEHICLES

Please note that the Warranty Policy and Procedure Manual in Section 9 on Page 8, spells out for those participating BMW centers the opportunity to self-authorize a rental vehicle if needed by your customer for this type of repair.

#### VALET COST

BMW of North America, LLC, will provide reimbursement for vehicle valet services (pick up & delivery) for each vehicle affected by this Service Action Campaign. Attach the appropriate receipt to the work order.

Defect Code 99 99 77 77 NA Valet Service

Sublet: \$25.00

Sublet Code: 4

#### ATTACHMENTS

- Customer Notification Letter 1 (vehicles previously repaired under Service Action 356)
- Customer Notification Letter 2 (vehicles with the first connecting rod bearings replacement)
- Questions & Answers

view PDF attachment [B110404CustLetter1](#)

view PDF attachment [B110404CustLetter2](#)

view PDF attachment [B110404Q&A](#)