

ENGINE	BARRA 190			E-GAS			BARRA 245T		BARRA 220		BOSS 260	
Engine Type	4.0L DOHC DIVCT I6			4.0L DOHC DIVCT I6			4.0L DOHC DIVCT I6 Turbo		5.4L SOHC 3V V8		5.4L DOHC 4V V8	
Compression ratio	10.3:1			10.7:1			8.7:1		9.7:1		9.5:1	
Maximum power (DIN)	190kW @ 5250rpm			156kW @ 5000rpm			245kW @ 5250rpm <sup>1</sup>		220kW @ 4750rpm		260kW @ 5250rpm <sup>1</sup>	
Maximum torque (DIN)	383Nm @ 2500rpm			374Nm @ 2750rpm			480Nm @ 2000rpm <sup>1</sup>		470Nm @ 3250rpm		500Nm @ 4000rpm <sup>1</sup>	
Bore x stroke	92.3 x 99.3mm			92.3 x 99.3mm			92.3 x 99.3mm		90.2 x 105.8mm		90.2 x 105.8mm	
Displacement (L)	3.984			3.984			3.984		5.408		5.408	
TRANSMISSION/RATIOS	Auto	Man	Auto	Auto	Man	Auto	Man	Auto	Auto	Man	Auto	Man
1st	2.39	3.35	-	4.17	2.66	2.39	4.17	2.97	2.39	4.17	2.97	2.97
2nd	1.45	1.92	-	2.34	1.78	1.45	2.34	1.78	1.45	2.34	1.78	1.78
3rd	1.00	1.29	-	1.52	1.30	1.00	1.52	1.30	1.00	1.52	1.30	1.30
4th	0.68	1.00	-	1.14	1.00	0.68	1.14	1.00	0.68	1.14	1.00	1.00
5th	-	0.72	-	0.87	0.80	-	0.87	0.80	-	0.87	0.80	0.80
6th	-	-	-	0.69	0.63	-	0.69	0.63	-	0.69	0.63	0.63
Reverse	2.09	3.15	-	3.40	2.90	2.09	3.40	2.90	2.09	3.40	2.90	2.90
FUEL	75L			90L (usable)			75L		75L		75L	
ELECTRICAL/CLUTCH	54Ah			-			54Ah		54Ah		54Ah	
Alternator	110A			-			110A		110A		110A	
Clutch type	Self-adjusting Diaphragm Spring			-			Diaphragm Spring		Self-adjusting Diaphragm Spring		Self-adjusting Diaphragm Spring	
Diameter	254mm			-			267mm		279mm		279mm	
MAXIMUM TOWING CAPACITY <sup>2</sup>	Manual			1200kg <sup>3,6</sup>			Automatic		2300kg <sup>4,5,6</sup> /1600kg <sup>3,6,7</sup>		E-Gas	
E-Gas	2300kg <sup>4,5,6</sup>			2300kg <sup>4,5,6</sup>			2300kg <sup>4,5,6</sup>		2300kg <sup>4,5,6</sup>		2300kg <sup>4,5,6</sup>	
EXTERIOR DIMENSIONS (mm)	XL		XLS				RTV		XR6	XR6	XR8	
	Cab Chassis <sup>8</sup>	Styleside Box	Cab Chassis <sup>8</sup>	Styleside Box	Cab Chassis <sup>8</sup>	Styleside Box	Cab Chassis <sup>8</sup>	Styleside Box	XR6	Turbo	XR8	
Overall length	5331	5069	5331	5069	5331	5069	5331	5069	5101	5101	5101	
Overall width <sup>9</sup>	1908	1871	1908	1871	1908	1871	1908	1898	1871	1871	1871	
Wheelbase	3095	3095	3095	3095	3100	3100	3100	3100	3095	3095	3095	
Front track	1553	1553	1553	1553	1584	1584	1584	1584	1553	1553	1553	
Rear track	1547	1547	1547	1547	1577	1577	1577	1577	1547	1547	1547	
Front overhang	909	909	909	909	909	909	909	909	932	932	932	
Rear overhang	1327	1065	1327	1065	1327	1065	1327	1065	1074	1074	1074	
CARGO DIMENSIONS (mm)	1-tonne		¾-tonne	1-tonne	1-tonne	Sports	1-tonne	1-tonne	Sports	Sports	Sports	
Suspension type	1-tonne		¾-tonne	1-tonne	1-tonne	Sports	1-tonne	1-tonne	Sports	Sports	Sports	
Floor level load length	2209.0		1818.8	2209.0	1818.8	2209.0	1818.8	1818.8	1818.8	1818.8	1818.8	
Belt level load length	2209.0		1848.0	2209.0	1848.0	2209.0	1848.0	1848.0	1848.0	1848.0	1848.0	
Wheelhouse cargo width	-		1204.5	-	1204.5	-	1204.5	1154.0	1154.0	1154.0	1154.0	
Floor and belt level rear opening width	1804.0		1394.0	1804.0	1394.0	1804.0	1394.0	1394.0	1394.0	1394.0	1394.0	
Liftover height	914.3		745.1	746.1	914.3	663.0	746.1	961.0	794.0	663.0	663.0	
Cargo depth	240.8		410.1	240.8	410.1	240.8	410.1	240.8	410.1	410.1	410.1	
VEHICLE MASSES (kg)	1-tonne		¾-tonne	1-tonne	1-tonne	Sports	1-tonne	1-tonne	Sports	Sports	Sports	
Suspension type	1-tonne		¾-tonne	1-tonne	1-tonne	Sports	1-tonne	1-tonne	Sports	Sports	Sports	
GVM	2805		2505	2805	2805	2350	2805	2805	2280	2280	2280	
Kerb mass	1545		1680	1700	1525	1685	1705	1575	1745	1730	1835	
Payload (maximum)	1260		825	1105	1280	665	1100	1230	1060	550	445	
Front axle load (maximum)	1165		1165	1165	1165	1165	1165	1165	1165	1165	1165	
Rear axle load (maximum)	1700		1380	1700	1700	1240	1700	1700	1170	1170	1170	
GCM – manual	3885		3585	3885	3885	3430	3885	3885	3885	3360	3360	
– auto	4245		3945	4245	4245	3790	4245	4245	4245	3720	3720	

#### VEHICLE MASS RULES

- A.** Kerb Mass and Payload values are approximate only. Kerb (unladen) Mass quoted includes full tank of fuel, and without occupants or luggage/cargo and with all standard equipment (plus air-conditioning option where not standard).
- B.** Kerb Mass values in table are given for Barra 190 engine with standard manual transmission (5-speed on XL, XLS, RTV and XR6) (6-speed on XR6T and XR8).
- C.** GVM (Gross Vehicle Mass) is defined as the sum of the Kerb Mass and the Payload, and must not exceed the relevant maximum allowable front and rear axle loads (as measured at the wheel to ground interface).
- D.** Payload (maximum) is defined as the maximum combined value for the occupants/cargo/added options/additional structures/towball download when towing.
- E.** For optional automatic transmission, add 22kg to the Kerb Mass and deduct 22kg from Payload (maximum).

- F.** For optional E-Gas engine, add 50kg to Kerb Mass and deduct 50kg from Payload.
- G.** For optional Barra 220 engine with either 1-tonne or standard suspension add 60kg to Kerb Mass, add 40kg to both GVM and GCM, and deduct 20kg from Payload (maximum).
- H.** For optional Barra 220 engine with sports suspension, add 60kg to Kerb Mass, maintain GVM and GCM, and deduct 60kg from Payload (maximum).
- I.** For optional heavy duty suspension, add 25kg to Kerb Mass and deduct 25kg from Payload (maximum).
- J.** For optional factory aluminium tray, add 115kg to Kerb Mass (for Cab Chassis) and deduct 115kg from Payload (maximum).
- K.** GCM quoted = GVM + Towing Capacity (1200kg for manual/1600kg for auto) – Towball loading (120kg for manual/160kg for auto). For optional 2300kg towing kit (auto only excluding XR6 Turbo) add 630kg to GCM for auto.

DRIVE RATIO	XL		XLS				RTV		XR6	XR6	XR8
Ratio	Cab Chassis	Styleside Box	Cab Chassis	Styleside Box	Cab Chassis	Styleside Box	Cab Chassis	Styleside Box	XR6	Turbo	XR8
3.23:1 <sup>A</sup>	O	S	S	S	O	O	-	-	-	-	-
3.45:1 <sup>B</sup>	-	-	-	-	-	-	-	-	-	-	S
3.45:1 <sup>C</sup>	S	O	O	O	S	S	S	S	-	-	-
2.73:1 <sup>D</sup>	-	-	-	-	-	-	-	-	-	O	O
3.73:1 <sup>E</sup>	-	-	-	-	-	-	-	-	-	S	-

#### DRIVE RATIO RULES

- A.** Standard on 3/4 tonne XL Styleside Box and XLS models. Mandatory when the 1-tonne option is specified with automatic transmission. Mandatory when Barra 220 engine option is specified on RTV with manual transmission.
- B.** Standard on XR8 (manual transmission only).

- C.** Standard on 1-tonne XL C/C (manual transmission only), RTV and XR6 models. Mandatory when the 1-tonne option is specified with manual transmission.
- D.** Mandatory on XR6 Turbo and XR8 when automatic transmission option specified.
- E.** Standard on XR6 Turbo manual transmission.

S – Standard. O – Options that can be ordered before a vehicle is manufactured. A – Options that can be added at any time.

1. Power and torque figures measured using Premium unleaded fuel (95 RON). 2. Subject to State and Territory regulations. 3. When fitted with Genuine Ford towbar. 4. When fitted with Genuine Ford heavy duty towbar and load levelling kit. 5. 4-speed transmission models require auxiliary transmission oil cooler, excluding RTV and Cab Chassis models. 6. Towball download and rear axle limits must not be exceeded. Please refer to your Ford Dealer for advice. 7. Maximum towing capacity of Falcon XR6 Turbo is 1,600kg. 8. Cab Chassis dimensions quoted with optional factory fitted tray. 9. Excludes exterior side mirrors.

FEATURES MECHANICAL	ALL MODELS	XL		XLS		RTV		XR6	XR6 TURBO	XR8
		C/C	SSB	C/C	SSB	C/C	SSB			
<b>Barra 190 4.0L DOHC DIVCT I6</b>	-	S	S	S	S	S	S	S	-	-
5-Speed manual transmission	-	S	S	S	S	S	S	S	-	-
4-Speed Sequential Sports Shift automatic transmission (including adaptive shift)	-	O	O	O	O	O	O	O	-	-
4-Speed column automatic transmission (including adaptive shift)	-	O	O	-	-	O	O	-	-	-
<b>E-Gas 4.0L DOHC DIVCT I6</b>	-	O	O	O	O	O	O	-	-	-
4-Speed Sequential Sports Shift automatic transmission (including adaptive shift)	-	S	S	S	S	S	S	-	-	-
4-Speed column automatic transmission (including adaptive shift)	-	O	O	-	-	O	O	-	-	-
<b>Barra 245T 4.0L DOHC DIVCT I6 Turbo</b>	-	-	-	-	-	-	-	-	S	-
6-Speed manual transmission	-	-	-	-	-	-	-	-	S	-
ZF 6-Speed Sequential Sports Shift automatic transmission (including adaptive shift)	-	-	-	-	-	-	-	-	O	-
<b>Barra 220 5.4L SOHC 3V V8<sup>10</sup></b>	-	O <sup>11</sup>	O <sup>11</sup>	O	O	O	O	-	-	-
4-Speed Sequential Sports Shift automatic transmission (including adaptive shift)	-	S	S	S	S	S	S	-	-	-
<b>Boss 260 5.4L DOHC 4V V8</b>	-	-	-	-	-	-	-	-	-	S
6-Speed manual transmission	-	-	-	-	-	-	-	-	-	S
ZF 6-Speed Sequential Sports Shift automatic transmission (including adaptive shift)	-	-	-	-	-	-	-	-	-	O
<b>RIDE &amp; HANDLING</b>										
Fully independent double wishbone front suspension	S	-	-	-	-	-	-	-	-	-
Hotchkiss rear suspension	S	-	-	-	-	-	-	-	-	-
3/4 tonne suspension	-	-	S	-	-	-	-	-	-	-
1-tonne suspension	-	S	O	S	O	S	S	-	-	-
Heavy duty suspension <sup>10</sup>	-	O	O	O	O	-	-	-	-	-
Sports suspension	-	-	-	-	S	-	-	S	S	S
Vented disc front brakes with twin piston caliper	-	S	S	S	S	S	S	S	-	-
Solid disc rear brakes with single piston caliper	-	S	S	S	S	S	S	S	-	-
Performance brakes with vented front disc with twin piston caliper	-	-	-	-	-	-	-	-	S	S
Performance brakes with vented rear disc with single piston caliper	-	-	-	-	-	-	-	-	S	S
Rack and pinion power assisted steering	S	-	-	-	-	-	-	-	-	-
Turns (lock-to-lock)	2.8	-	-	-	-	-	-	-	-	-
Turning circle (kerb-to-kerb)	11.5	-	-	-	-	-	-	-	-	-
16" X 6.5" silver steel wheel (rated 1-tonne) – 215/60 R16 99H tyre <sup>11</sup>	-	-	S	-	-	-	-	-	-	-
16" X 6.5" silver steel wheel (rated 1-tonne) – 215/60 R16 C 1-tonne tyre <sup>11</sup>	-	S	-	-	-	-	-	-	-	-
16" X 7.0" alloy wheel (rated 1-tonne) – 215/60 R16 C 1-tonne tyre	-	-	-	S	-	-	-	-	-	-
16" x 7.0" alloy wheel (rated 1-tonne) – 215/55 R16 95W tyre	-	-	-	-	S	-	-	-	-	-
16" x 7.0" alloy wheel (rated 1-tonne) – 215/65 R16 C 1-tonne tyre	-	-	-	-	-	S	S	-	-	-
17" x 8.0" alloy wheel – 235/45 R17 93W tyre	-	-	-	-	-	-	-	S	S	S
16" x 6.5" silver steel spare wheel (rated 1-tonne) <sup>12</sup>	-	S	S	S	S	-	-	S	-	-
17" x 7.5" black steel spare wheel <sup>12</sup>	-	-	-	-	-	-	-	-	S	S
16" x 7.0" silver steel spare wheel (rated 1-tonne) <sup>12</sup>	-	-	-	-	-	S	S	-	-	-
Limited Slip Differential (LSD)	-	O	O	O	O	-	-	O	S	S
Differential locking system (with remote dash mounted switch)	-	-	-	-	-	S	S	-	-	-
<b>EXTERIOR</b>										
Body colour mirrors	-	-	-	S	S	-	-	S	S	S
Body colour body side protection mouldings	-	-	-	S	S	-	-	S	S	S
Variable speed intermittent windscreen wipers	S	-	-	-	-	-	-	-	-	-
Rear/side demister	S	-	-	-	-	-	-	-	-	-
On-glass antenna	S	-	-	-	-	-	-	-	-	-
Wiring facility for cargo lamp and high mount stop lamp	S	-	-	-	-	-	-	-	-	-
Polyethylene loadbed	-	-	S	-	S	-	S	S	S	S
Tonneau cover – black with 2 steel bows <sup>13</sup>	-	-	A/O	-	S	-	A/O	S	S	S
Underbody protection shields	-	-	-	-	-	S	S	-	-	-
Wheel arch fender flares	-	-	-	-	-	S	S	-	-	-
Delete tonneau hooks	-	-	O	-	O <sup>14</sup>	-	O	O <sup>14</sup>	O <sup>14</sup>	O <sup>14</sup>
Aluminium tray	-	O	-	O	-	-	-	-	-	-
Aluminium tray (with side steps and rear mudflaps)	-	-	-	-	-	O	-	-	-	-
Rear mudflaps	-	-	-	-	-	-	S	-	-	-
Partial body styling kit	-	-	-	S	S	-	-	-	-	-
Full body styling kit	-	-	-	-	-	-	-	S	S	S
Dual outlet exhaust system – chrome tip	-	-	-	-	-	-	-	-	S	S
Ladder rack <sup>15</sup>	-	-	A	-	A	-	A	A	A	A

10. ABS mandatory with Barra 220 engine option and/or heavy duty 1-tonne suspension. 11. 16" x 7" 1-tonne rated alloy wheel mandatory with Barra 220 engine option on XL models. 12. Spare tyre supplied is identical to standard tyre fitted, dependent upon model, engine and suspension combination. 13. Not supplied when delete tonneau hooks option specified. 14. Soft tonneau cover not supplied when this option specified. 15. Not available on vehicles with hard tonneau cover.

INTERIOR	ALL MODELS	XL		XLS		RTV		XR6	XR6 TURBO	XR8
		C/C	SSB	C/C	SSB	C/C	SSB			
Interior Command Centre featuring audio and climate LCD screen	S	-	-	-	-	-	-	-	-	-
Carpet floor covering	-	O	O	S	S	O	O	S	S	S
Rubber floor covering	-	S	S	-	-	S	S	-	-	-
Unique XR carpet mats (available in blue, grey or red)	-	-	-	-	-	-	-	A	A	A
Adjustable rake and reach steering column (floor shift only) <sup>16</sup> .	S	-	-	-	-	-	-	-	-	-
Leather wrapped steering wheel	-	-	-	S	S	-	-	S	S	S
Sports leather steering wheel	-	-	-	-	-	-	-	O	O	O
Momo steering wheel (available in blue, grey or red) <sup>17</sup> .	A/O	-	-	-	-	-	-	-	-	-
Momo gear knob <sup>18</sup> ./Sequential Sports Shifter <sup>19</sup> . (available in blue, grey or red)	-	A	A	A	A	A	A	A	A <sup>20</sup> .	A <sup>20</sup> .
Alloy pedal covers	-	A	A	A	A	A	A	S	S	S
Cruise control with steering wheel mounted controls	-	A/O	A/O	S	S	A/O	A/O	S	S	S
Power mirrors <sup>21</sup> .	S	-	-	-	-	-	-	-	-	-
Power windows with engine off time delay	S	-	-	-	-	-	-	-	-	-
Automatic headlamps ON/OFF	S	-	-	-	-	-	-	-	-	-
Air-conditioning <sup>22</sup> .	-	A/O	A/O	A/O	A/O	A/O	A/O	S	S	S
Pollen air filter	A	-	-	-	-	-	-	-	-	-
Illuminated entry/exit - remote activated	-	-	-	S	S	-	-	S	S	S
Key-out courtesy light	S	-	-	-	-	-	-	-	-	-
Auto-off interior light	S	-	-	-	-	-	-	-	-	-
Driver/passenger adjustable reading lamps	S	-	-	-	-	-	-	-	-	-
Sports instrument cluster with blue illumination and unique XR graphics	-	-	-	-	-	-	-	S	S	S
Trip computer including trip time, fuel used, average fuel, average speed, distance-to-empty	S	-	-	-	-	-	-	-	-	-
LCD display including trip computer, odometer and speed alert indicator (audible warning)	S	-	-	-	-	-	-	-	-	-
<b>INTERIOR STORAGE</b>										
Centre console bin with lid (except with fixed centre seat) <sup>16</sup> .	S	-	-	-	-	-	-	-	-	-
Cup holders, door bins, ICC storage console	S	-	-	-	-	-	-	-	-	-
Cabin tidy	A	-	-	-	-	-	-	-	-	-
Lockable glove box	S	-	-	-	-	-	-	-	-	-
Driver and passenger coat hooks	S	-	-	-	-	-	-	-	-	-
Cargo swing net	-	A	A	A	A	A	A	S	S	S
<b>SEATING</b>										
Cloth trim bucket seats	-	S	S	-	-	S	S	-	-	-
Fixed centre seat with lap/sash seat belt <sup>23</sup> .	-	O	O	-	-	O	O	-	-	-
Cloth trim sports bucket seats	-	-	-	S	S	-	-	S	S	S
4-way power adjustment for driver <sup>16</sup> .	S	-	-	-	-	-	-	-	-	-
Adjustable lumbar support for driver	S	-	-	-	-	-	-	-	-	-
Adjustable lumbar support for passenger	-	-	-	S	S	-	-	S	S	S
Quick-tilt forward seats	S	-	-	-	-	-	-	-	-	-
<b>AUDIO</b>										
100 watt AM/FM stereo radio with single CD	S	-	-	-	-	-	-	-	-	-
100 watt AM/FM stereo radio with 6-disc in-dash CD (prestige) <sup>16,24</sup> .	O	-	-	-	-	-	-	-	-	-
Steering wheel mounted audio controls	S	-	-	-	-	-	-	-	-	-
<b>SAFETY &amp; SECURITY</b>										
Driver airbag	S	-	-	-	-	-	-	-	-	-
Passenger airbag	O	-	-	-	-	-	-	-	-	-
Adjustable seatbelt height	S	-	-	-	-	-	-	-	-	-
Beltminder™ system (light and audible warning - driver only)	S	-	-	-	-	-	-	-	-	-
Pyrotechnic seatbelt buckle pretensioner	S	-	-	-	-	-	-	-	-	-
Restraints control module, driver seat position sensor, crash severity sensor	S	-	-	-	-	-	-	-	-	-
Child seat anchorage point	S	-	-	-	-	-	-	-	-	-
Smartshield security system	S	-	-	-	-	-	-	-	-	-
Remote central locking	S	-	-	-	-	-	-	-	-	-
Anti-lock Brakes (ABS)	-	O	O	O	O	S	S	S	S	S
Traction Control	-	-	-	-	-	-	-	S	S	S
<b>TOWING</b> Figures quoted are for braked trailer, using Genuine Ford towpack.										
1600kg rated (auto)/1200kg rated (manual) towpack <sup>25</sup> .	A/O	-	-	-	-	-	-	-	-	-
2300kg rated heavy duty towpack (auto only) <sup>26</sup> .	-	A	A	A	A	A	A	A	-	A

16. Not available with column shift auto option. 17. Must specify cruise control. 18. Available on manual transmission only. 19. 4-speed automatic transmission only. 20. Sequential Sports Shifter not available on this model. 21. RTV fitted with convex mirrors. 22. Mandatory with 6-disc audio option. 23. Only available with column shift auto option. 24. Must specify air-conditioning. 25. Includes towbar, towball and trailer wiring. 26. Includes towbar, towball, trailer wiring and load levelling kit. 4-speed transmission models require auxiliary transmission oil cooler, excluding RTV and Cab Chassis models.

## [ XL/XLS Styleside Box ]

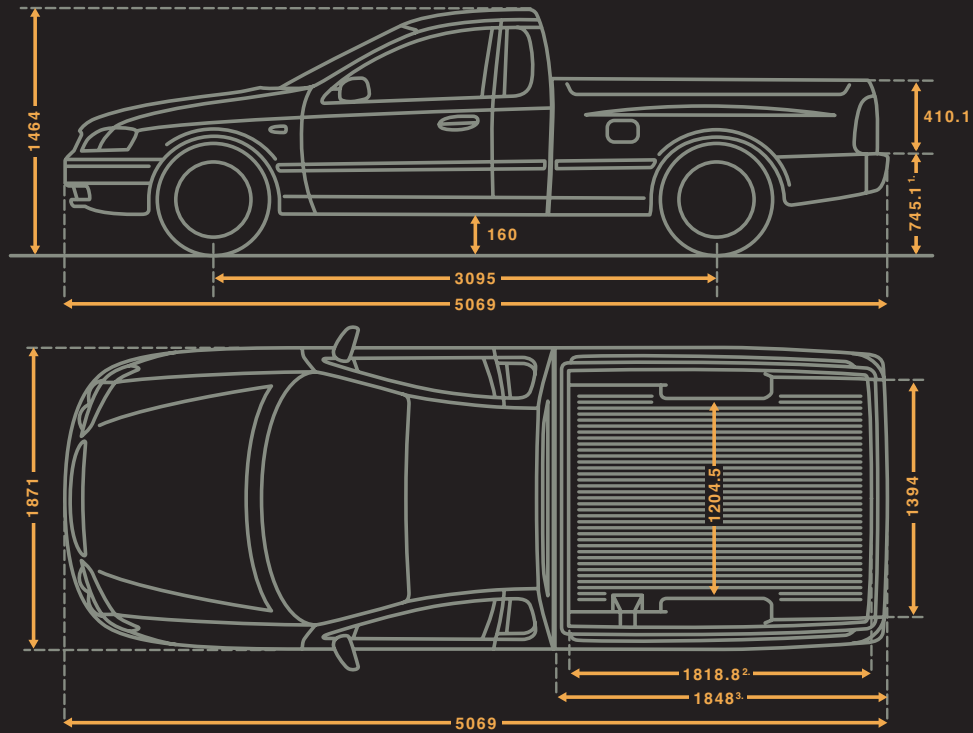

## [ XL/XLS Cab Chassis ]

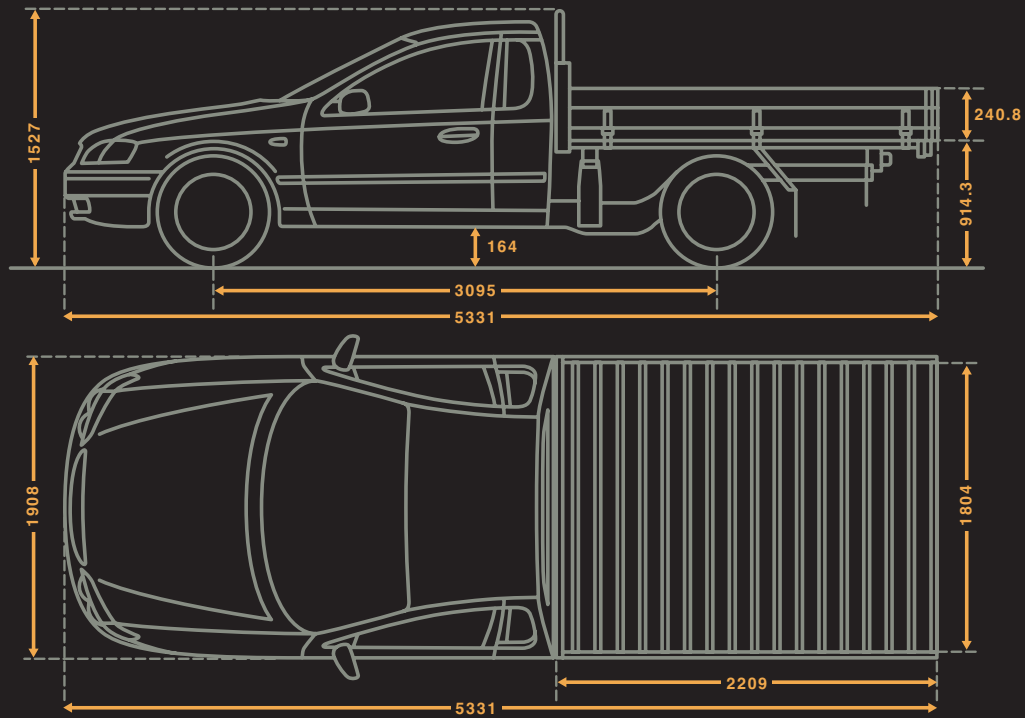

1. XL Styleside Box standard suspension liftover height quoted. XL and XLS Styleside Box 1-tonne suspension = 746.1 mm. XLS Styleside Box sports suspension = 663mm. 2. Measurement refers to base of Styleside Box. 3. Measurement refers to top of Styleside Box.