

FALCON UTE



Go Further

Play hard

| Good times are just around the corner with the Falcon Ute. |



Falcon XR6 Turbo Ute shown in Kinetic with optional Luxury Pack (Includes 19" alloy wheels).

When the work day is over, the Falcon Ute comes into its own. Nothing proves it more than the Falcon XR Ute. Slick design, low stance and full body styling kit meets an 8" colour touch screen, car-like comfort and superb driving performance. Inside and out, it takes fun seriously.

Work hard

Get the job done with the Falcon Ute. Tough, powerful and always ready for work.



Falcon XR6 Cab Chassis shown in Lightning Strike with optional aluminium tray.

Falcon Ute has the brute strength and power to tackle just about any job going. There are payloads of up to 1.2 tonnes* and towing capacities of up to 2,300kg.# And with its car-like comfort, dynamic handling and a host of smart on-board technologies, working conditions have never been better.

*Standard on Falcon Ute base model Cab Chassis and available on XR6 Cab Chassis with optional 1-tonne suspension. #Braked towing capacity of vehicles with optional automatic transmission, when fitted with Genuine Ford heavy duty towpack including load levelling kit. Subject to State and Territory regulations.

A real workhorse

Built for heavy payloads and with serious towing power, the Falcon Ute means business.



Falcon XR6 Styleside Box shown in Kinetic. Falcon Ute Cab Chassis shown in Lightning Strike with optional aluminium tray.

Whether you're loading up the tools or towing the boat, the Falcon Ute is a true workhorse. The Styleside Box has a tough, fully integrated bedliner to protect your work equipment against daily wear and tear. And with the Cab Chassis option, you can choose the factory fitted aluminium tray or tailor something for your own specific needs.

Car-like comfort

The perfect antidote to a long day on the job, the Falcon Ute's interior is smart, stylish and comfortable.



Falcon XR Ute interior shown with optional automatic transmission.

After a long day on the job, the 4-way power adjustable driver's seat is the perfect place to be. Enjoy a long, engaging drive or simply relax in the peace and quiet of the ergonomically designed interior. The spacious cabin in the Falcon Ute maximises space and comfort drawing you in from the moment you turn the key.



Bluetooth® mobile phone integration:

Hands free communication is integrated into the vehicle's audio system to make driving smarter and safer.



Advanced integration.

Listening to your favourite songs and staying connected is easier than ever. From the Falcon Ute's 8" colour touch screen* you can take full control of your iPod,** smart phone, MP3 or USB device, keeping you hooked into your music and your life wherever you go.

Technology at your fingertips

Toolled up with the latest technology, the Falcon Ute puts the controls firmly in your hands.



Human Machine Interface (HMI).

Incorporating the Interior Command Centre (ICC), steering wheel controls and multi-function display, the HMI allows for simple operation of various vehicle functions. This greatly increases safety by bringing driving information and audio controls together on the 8" colour touch screen,* ensuring your eyes spend more time on the road than off it.



Satellite navigation:

With keyword search, Traffic Message Channel (TMC)* and easy-to-read colour maps, you can get where you need to be quickly and efficiently.



Multi-function display.

The easy-to-read multi-function display allows you to check everything at a glance, from speed and journey distance to temperature, vehicle warnings and more.



Falcon XR Ute interior shown with optional Luxury Pack.



Cruise control.

Steering wheel mounted controls conveniently place smoother driving and even speed right at your fingertips.

Comprehensive iPod** and USB integration plus Bluetooth® mobile phone integration* with steering wheel controls, puts the technology on-board the Falcon Ute right at your fingertips. And with a satellite navigation system* available in the optional Luxury Pack, you can get where you want to go quickly, efficiently and without fuss.

*Bluetooth® is a registered trademark of Bluetooth SIG Inc., and is used under licence. Customers should consult their Ford Dealer on the ability of their mobile phone handset to integrate with the Bluetooth® system prior to making a purchase decision. **Standard on XR models and optional on Falcon Ute base models. †Only available as part of the optional Luxury Pack on XR6 and XR6 Turbo. Not available on Falcon Ute base models. ‡Ford has an arrangement to provide the Suna Traffic Channel broadcast for a minimum of 5 years from the time of vehicle manufacture. Coverage includes Melbourne, Sydney, Brisbane, Canberra, Adelaide, Perth and Gold Coast metropolitan areas. Refer to www.sunattraffic.com.au for full details. **iPod is a trademark of Apple Inc. Please refer to ford.com.au for iPod compatibility.



4.0L Turbo I6 engine.

Delivers the type of performance that is guaranteed to get the adrenalin pumping. The turbo system creates an awesome 270kW of power and 533Nm of torque.



EcoLPI engine.

Designed to deliver serious power and torque but with reduced running costs and environmental impact, Ford's EcoLPI engine is a truly innovative piece of technology.

Power meets performance

| A range of powerful engines and responsive transmissions, | offer a smooth, car-like driving experience.



Falcon XR6 Turbo Ute shown in Mars Red with optional towpack and accessory EGR hard tonneau cover.



4.0L I6 engine.

Fuel efficient, yet boasting 195kW of power and 391Nm of torque, this engine is a real workhorse.



ZF 6-speed automatic transmission.

Employing advanced mechatronic units that deliver precise control and refinement to all 6 gears, the ZF transmission ensures smooth delivery of power and torque for a thoroughly enjoyable drive.

Falcon Ute offers you a range of smart and technologically advanced engines, from the torquy 4.0L I6 and the breathtaking I6 Turbo, to the economical yet powerful EcoLPI. You can choose to get more involved with the responsive 6-speed manual transmission, or enjoy the smoothness of the ZF 6-speed automatic. And with a car-like front suspension system and precision tuned rear suspension, you're guaranteed incredible control, power and an altogether smoother ride.

ULP Fuel Consumption

LPG Fuel Consumption

Save up to 40%[^]

Fuel cost comparisons.

With petrol prices rising, it's a good time to consider the alternatives and with EcoLPi you could save up to 40%[^] compared with a petrol model without sacrificing power and torque. The EcoLPi engine delivers an exhilarating 198kW of power and 409Nm of torque to ensure you continue to get the performance you've come to expect in a tough workhorse. As an LPG user, you may also be eligible for a \$2000 government rebate.*

EcoLPi smart engine technology

Enjoy outstanding power and torque while taking advantage of the fuel cost benefits of LPG.



EcoLPi Falcon XR6 Styleside Box shown in Lightning Strike.



Ford's EcoLPi engine* uses LPG fuel for lower environmental impact and considerable cost savings. For three years, the EcoLPi engine was exhaustively tested with a fleet of trial vehicles driving over 550,000kms across every State and Territory in the nation, through tough climates and terrains. The result is an engine that delivers more power and torque than a petrol engine, as well as outstanding running cost savings and reduced carbon emissions.

[^]Fuel costs and savings calculated using ADR 81/02 fuel consumption figures of 10.7L/100km (Falcon Ute with 4.0L petrol engine and 6 speed auto) and 13.9L/100km (Ford Falcon Ute with optional EcoLPi engine and 6 speed auto). Estimated fuel costs are calculated using the average fuel price for the five major Australian capital cities of 0.6c/L (LPG) and 1.39c/L (unleaded petrol) from Dec 2010 to Nov 2011. Source: www.motormouth.com.au. The estimated fuel cost savings based on fuel costs to travel 20,000km and are: Falcon Ute 4.0L petrol \$2,975 and Falcon Ute EcoLPi \$1,779. Fuel cost savings are true for the example given and changes in unleaded petrol and LPG prices will alter the cost savings calculations. *Optional EcoLPi not available on XR6 Turbo. #From 1 July 2011 the LPG Vehicle Scheme has been capped at 25,000 eligible claims paid in each financial year for the duration of the scheme to 30 June 2014. Should the 25,000 cap be reached before the end of the financial year, application processing will continue and eligible claims will be paid in the following financial year. Grant amounts for eligible applications will be determined from the date of new LPG vehicle purchase. For further information regarding the LPG Vehicle Scheme please visit www.ausindustry.gov.au.

Safety in the workplace

Safety is a priority. The ANCAP 5-star rated Falcon Ute is equipped with the very latest safety features and technologies.

Beltminder™ system.

A simple but effective system that offers an audible reminder for passengers to fasten their seatbelts, increasing safety at all speeds.

Dynamic Stability Control (DSC).

DSC helps keep your vehicle under control, by strengthening your connection to the road to reduce over-steer and under-steer, and by tracking and adjusting the vehicle's movement using the Traction Control and ABS. Now standard across the range.

Follow-me-home lighting.

Front headlights that remain lit for a short period after the vehicle is locked, providing lighting to guide you to your door.

Antilock Braking system (ABS).

The latest Anti-lock Braking System with Electronic Brakeforce Distribution (EBD) is standard across the range.

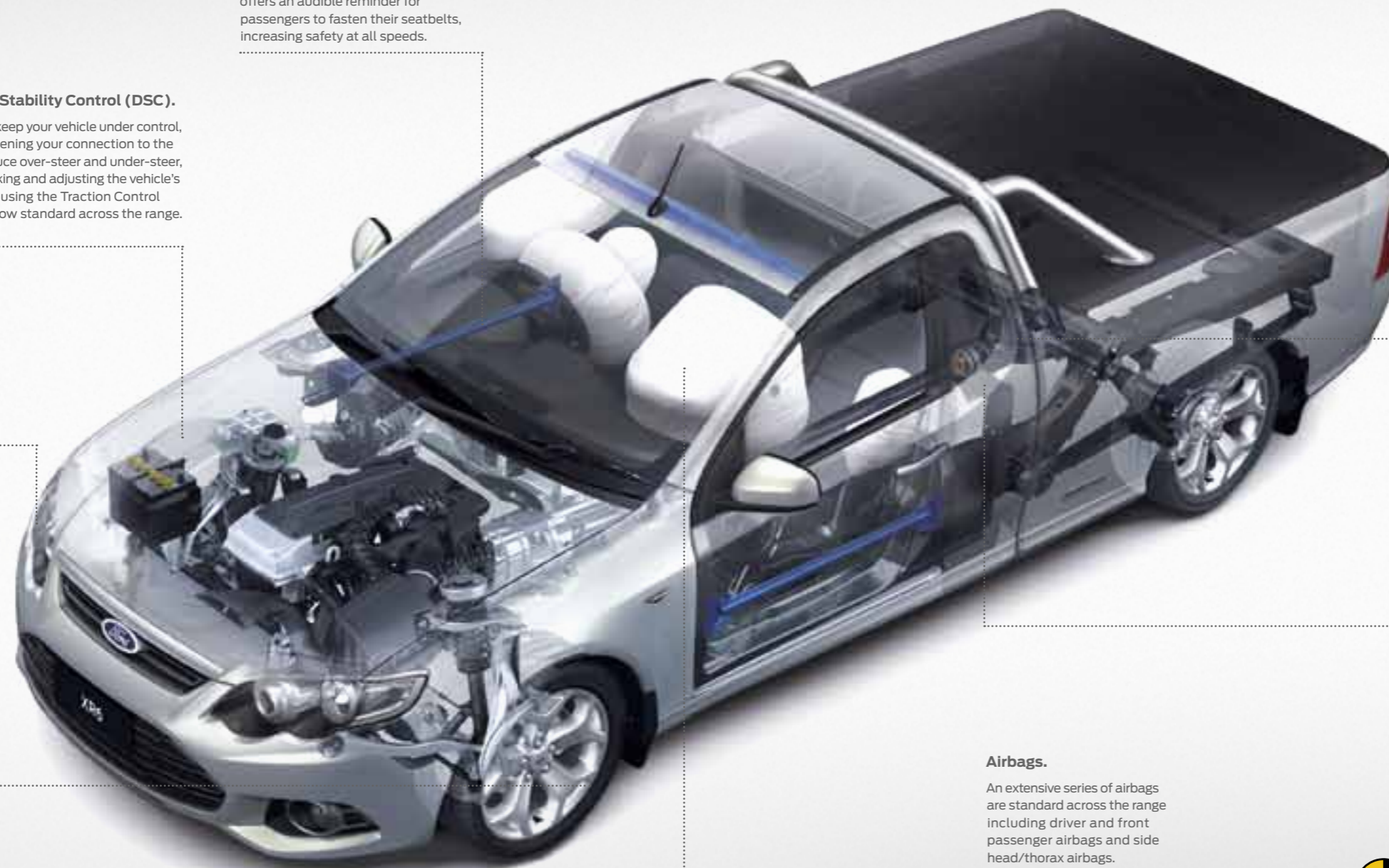

Limited Slip Differential (LSD).#

Helps to maintain traction on slippery surfaces or where the rear wheels are on different types of road surface.

#Standard on all models. Optional on Falcon Ute base model with automatic transmission.

Supercab design.

Provides a generous space behind the seats that also gives you a lockable storage area.

Airbags.

An extensive series of airbags are standard across the range including driver and front passenger airbags and side head/thorax airbags.



Australia's highest safety rating.

In addition to a long list of standard features, you have added peace of mind knowing that the entire Falcon Ute range has a 5-star ANCAP safety rating.



Keyless entry.

Ford's remote control flip key fits neatly in the pocket and offers convenient keyless entry and central locking.



Fatigue warning.

Tackling one of the largest hazards to road safety, this feature sounds a warning to drivers to rest after prolonged periods of continuous driving.



Side head/thorax airbags.

Now standard across the range, side head/thorax airbags help to reduce the severity of injury to the driver and front passenger in the case of impact.



Immobiliser.

Standard on all models, the electronic immobiliser provides high security protection for your Falcon Ute.

The Falcon Ute range

Work hard or play hard, with a Falcon Ute range that's bursting with power, performance and style.



Falcon Ute Cab Chassis shown in Lightning Strike with optional aluminium tray. Falcon XR6 Turbo Ute shown in Swift with optional Luxury Pack (includes 19" alloy wheels).

From the base model Cab Chassis to the top of the range XR6 Turbo, there's a Falcon Ute for you. Tough and powerful, yet offering the driveability and comfort you'd expect from a car. The Falcon Ute is made for the hard work, but is just as ready to play hard.

Cab Chassis

| Get back to basics with a cab chassis that means serious business. |



Falcon Ute Cab Chassis shown in Lightning Strike with optional aluminium tray.



Falcon XR6 Cab Chassis shown in Lightning Strike with optional aluminium tray.

Versatile and flexible, the Falcon Ute Cab Chassis offers you the choice of a factory fitted aluminium tray or to have one tailored to fit your specific work needs. Either way, the Falcon Ute Cab Chassis is always ready to work. And with an interior loaded with the latest safety, comfort and driving technologies, you've got a vehicle that's comfortable in any surroundings.

FALCON UTE

6-speed manual or optional ZF 6-speed auto[∞]

Optional 6-speed automatic column shift transmission

One-tonne suspension (1)

USB and iPod[®] integration (2)

Bluetooth[™] mobile phone integration

Cruise control with steering wheel mounted controls (3)

Driver, front passenger and side head/thorax airbags (4)

Dynamic Stability Control (DSC) incorporating Traction Control and Emergency Braking Assist (EBA)

Anti-lock Braking System (ABS) with Electronic Brakeforce Distribution (EBD)

Limited Slip Differential (LSD)^{**}

Optional fixed centre seat[‡]

Optional aluminium tray

XR6

Includes most base model features,[†] plus:

Standard sports suspension

Optional one-tonne suspension[†]

Premium ICC with 8" colour touch screen

18" alloy wheels

Sports leather wrapped steering wheel

Cloth trim sports seats

Standard Limited Slip Differential (LSD)

Projector headlamps

Fog lamps



[∞]Automatic Transmission standard with EcoLPi engine. [†]iPod is a trademark of Apple Inc. Please refer to www.ford.com.au for iPod compatibility. [™]Bluetooth is a registered trademark of Bluetooth SIG Inc., and is used under licence. Customers should consult their Ford Dealer on the ability of their mobile phone handset to integrate with the Bluetooth system prior to making a purchase decision. ^{**}Standard on Falcon Ute with manual transmission. Optional on Falcon Ute with automatic transmission. [‡]Only available with optional automatic column shift transmission. ^{††}Optional fixed centre seat and column shift transmission not available on XR models. One-tonne suspension optional on XR6 Cab Chassis models. ^{†††}16" alloy wheels fitted when 1-tonne suspension is optioned.

Styleside box

| The Styleside Box is eager to work and just as eager to play. |



Falcon Ute Styleside Box shown in Petroleum.



Falcon XR6 Styleside Box shown in Petroleum.



Falcon XR6 Turbo Ute shown in Petroleum.

The Falcon Ute Styleside Box is just as at home on the town as it is on the worksite. With a tough, fully integrated bedliner, it protects your work equipment from daily wear and tear. With sporty, sleek lines and commanding road presence, there's simply no mistaking the Falcon XR Ute.

FALCON UTE

6-speed manual or optional ZF 6-speed auto*

Optional 6-speed automatic column shift transmission

Optional one-tonne suspension

USB and iPod® integration

Bluetooth®- mobile phone integration (1)

Cruise control with steering wheel mounted controls

Driver, front passenger and side head/thorax airbags

Dynamic Stability Control (DSC) incorporating Traction Control and Emergency Braking Assist (EBA)

Anti-lock Braking System (ABS) with Electronic Brakeforce Distribution (EBD)

Limited Slip Differential (LSD)**

Optional fixed centre seat‡

XR6

Includes most base model features,† plus:

Flush fit soft tonneau cover (2)

Standard sports suspension

Premium ICC with 8" colour touch screen

18" alloy wheels

Sports leather wrapped steering wheel

Cloth trim sports seats

Alloy sports bar

Standard Limited Slip Differential (LSD)

Optional XR Luxury pack

- 19" alloy wheels

- SatNav with Traffic Massage Channel (TMC)° (3)

- Leather trim sports seats (4)

- Premium audio system

- Dual-zone climate control

Projector headlamps

Fog lamps

XR6 TURBO

Includes most XR6 features, plus:

4.0L I6 Turbo engine

Chrome exterior accents



1



2



3

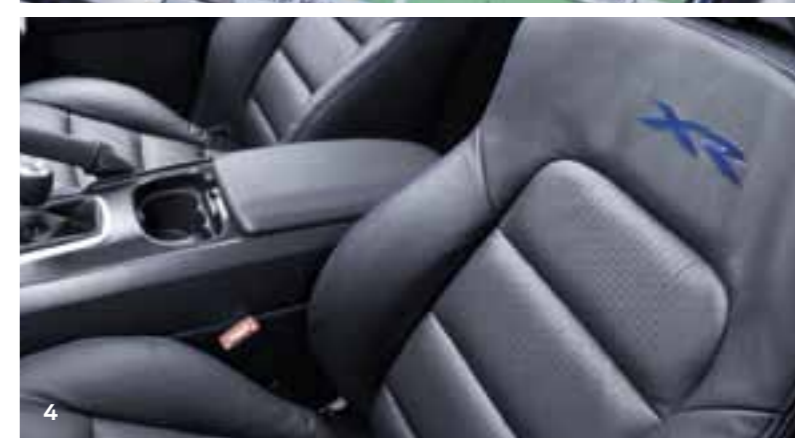

4

*Automatic Transmission standard with EcoLPi engine. †iPod is a trademark of Apple Inc. Please refer to www.ford.com.au for iPod compatibility. ‡Bluetooth® is a registered trademark of Bluetooth SIG Inc., and is used under licence. Customers should consult their Ford Dealer on the ability of their mobile phone handset to integrate with the Bluetooth® system prior to making a purchase decision. †One-tonne suspension not available on XR6 Styleside Box models. **Standard on Falcon Ute with manual transmission. Optional on Falcon Ute with automatic transmission. ‡Only available with optional automatic column shift transmission. *Optional fixed centre seat and column shift transmission not available on XR models. °Ford has an arrangement to provide the Suna Traffic Channel broadcast for a minimum of 5 years from the time of vehicle manufacture. Coverage includes Melbourne, Sydney, Brisbane, Canberra, Adelaide, Perth and Gold Coast metropolitan areas. Refer to www.sunatrafic.com.au for full details.

Colours and trim

With a great range of stylish colours and trims, you can customise the new Falcon Ute and make it yours.

EXTERIOR COLOURS



Winter White



Silhouette[^]



Lightning Strike[^]



Vanish[^]



Vixen



Emperor[^]



Kinetic[^]



Swift[^]



Mars Red[^]



Petroleum[^]



Falcon Ute
16" x 6.5" steel



XR6 Cab Chassis
(with optional 1-tonne suspension)
16" x 7.0" alloy



XR6 and XR6 Turbo
(standard)
18" x 8.0" alloy



XR6 Styleside Box and XR6 Turbo
(part of optional Luxury Pack)
19" x 8.0" alloy

INTERIOR TRIMS

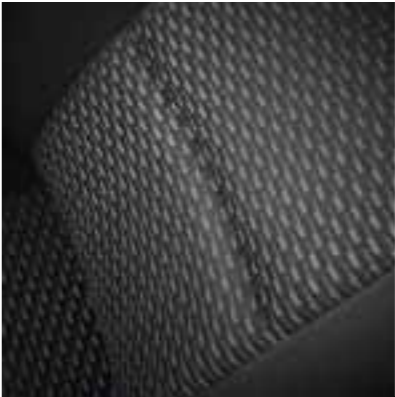

Falcon Ute
Metro Shadow cloth trim seats with Jacob Shadow bolsters.

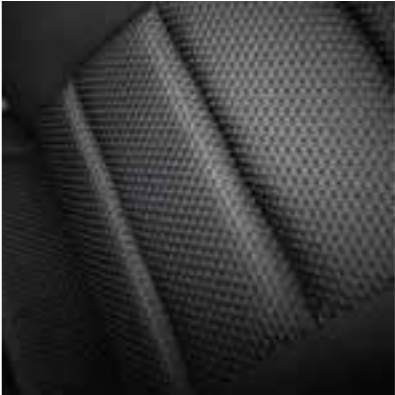

XR6 and XR6 Turbo
(standard)
Streetwise Graphite cloth trim seats with Attitude Shadow bolsters and XR embroidery.



XR6 and XR6 Turbo
(optional)
Nudo Shadow Weave Leather trim seats with Nudo Shadow Leather bolsters and XR embroidery.

[^]Not available on Falcon Ute Models.
[^]Prestige paint is an option that incurs an additional charge.

Details make the difference

Get exactly what you want from your Falcon Ute, by picking the perfect features and accessories to tailor it to your needs and requirements.



Spoiler. Designed for use with the EGR hard tonneau cover with power bulge. Makes your Falcon Ute look even more sporty.



Rubber floor mats. Help protect the floor of your vehicle from water, mud and sand with this set of premium, heavy duty rubber floor mats.



Scuff plates. Available as a set of two, these stylish alloy scuff plates feature either the 'Ford' or 'XR' logo.



Garmin Nüvi portable satellite navigation systems. The easy-to-read navigation systems give you clear directions to your destination.



EGR hard tonneau cover. Lightweight and impact resistant, this cover helps keep your equipment secure and protected from rain and dust.



Fridge 'Day Tripper' 15L. Connects to the 12V power outlet in the vehicle to keep food and drinks cool on the worksite.



Soft tonneau cover. The flush-fit soft tonneau cover is stylish and flexible enough to handle a range of load types.



XR waterproof seat covers. Help protect your seat fabric from dirt, sand and liquids and everyday wear and tear.



Cabin tidy. The clever design of the cabin tidy makes it ideal for storing loose items.



Perimeter alarm. Exclusively designed for Falcon Ute, and is fully integrated with the vehicle's central body computer.



Towpack. Choose the standard towpack for a carrying capacity of up to 1,600kg, or the heavy duty towpack (including load levelling kit) for towing up to 2,300kg.*



EGR 3 piece hard tonneau cover. Features single point push button locking mechanism, the hard tonneau cover helps keep your valuable equipment and tools secure. Compatible with XR sports bar.

Accessories

	Falcon Ute C/C	Falcon Ute SSB	XR6 C/C	XR6 SSB	XR6 Turbo SSB
Exterior styling					
16" x 7" 5-spoke alloy wheels (rated 1-tonne) ¹	A	A	-	-	-
EGR 3 piece hard tonneau cover ³	-	A	-	A	A
EGR 1 piece hard tonneau cover ³	-	A	-	-	-
EGR flat hard tonneau cover ³	-	A	-	-	-
EGR leather grain hard tonneau cover ³	-	A	-	-	-
Alloy sports bar	-	A	-	S	S
Spoiler	-	A	-	A	A
CSA Raker 17" alloy wheels ^{1,3,4}	-	-	A ²	A	A
CSA Haze 17" alloy wheels ^{1,3,4}	-	-	A ²	A	A
CSA Raker 18" alloy wheels ^{1,3,4}	-	-	A	A	A
CSA Vanquish 18" alloy wheels ^{1,3,4}	-	-	A ²	A	A
CSA Haze 18" alloy wheels ^{1,3,4}	-	-	A ²	A	A
CSA Vanquish 19" alloy wheels ^{1,3,4}	-	-	-	A	A
Exterior protection					
Bonnet protector / headlamp guards / weathershields	A	A	A	A	A
Mudspats - front ⁵	A	A	A	A	A
Soft tonneau cover ⁶	A	A	A	-	-
Interior styling, comforts and storage					
Carpet mats / rubber floor mats	A	A	A	A	A
Scuff plates (set of 2)	A	A	A	A	A

S = Standard. O = Optional. A = Accessory that can be added at any time. - = Not available.

	Falcon Ute C/C	Falcon Ute SSB	XR6 C/C	XR6 SSB	XR6 Turbo SSB
Interior styling, comforts and storage (continued)					
Cabin tidy	A ⁷	A ⁷	A	A	A
Cargo swing net	A	A	A	A	A
Dash mat	A	A	A	A	A
Pollen filter	A	A	A	A	A
Smoker's pack	A ⁷	A ⁷	A	A	A
XR waterproof seat covers ⁸	-	-	A	A	A
In car entertainment and electrical					
Garmin Nüvi portable satellite navigation system ²	A	A	A	A	A
Go Technologies rear camera bumper mount ³	A	A	A	A	A
Go Technologies reversing camera system ³	A	A	A	A	A
Go Technologies wireless adaptor ³	A	A	A	A	A
Fridge 'Day Tripper' 15L/fridge power adaptor	A	A	A	A	A
Safety and security					
Perimeter alarm	A	A	A	A	A
Towing and carrying					
Towpack - standard 1600kg rated (auto)/1200kg rated (manual) ⁹	O/A	O/A	O/A	O/A	O/A
Towpack - heavy duty 2300kg rated (incl. load levelling kit) ^{9,10}	A	A	A	A	A
Rhino-Rack sportz carry bars ³	A	A	A	A	A

¹This accessory is a Supplier Branded Accessory and is not manufactured or warranted by Ford. The warranty is provided by the manufacturer of the accessory. Contact your Authorised Ford Dealer for details of the accessory manufacturer's warranty applicable to this accessory. ²Subject to State and Territory regulations.

¹Wheels and tyres sold separately when fitted in Dealership. ²Not available with optional 1-tonne suspension. ³This accessory is a Supplier Branded Accessory and is not manufactured or warranted by Ford. The warranty is provided by the manufacturer of the accessory. Contact your Authorised Ford Dealer for details of the accessory manufacturer's warranty applicable to this accessory. ⁴It is recommended that tyres matching original equipment specification be fitted to CSA alloy wheels. ⁵Rear mudspats standard on Falcon Ute models. ⁶Available for standard Styleside Box, for sports bar and when optional factory aluminium tray is fitted to Cab Chassis models. ⁷Not available when optional column shift automatic is specified. ⁸Driver and front passenger seat covers sold separately. ⁹Subject to State and Territory regulations. ¹⁰Available on automatic transmission models only.

Mechanical specifications

Engine type	4.0L DOHC DI-VCT I6		EcoLPi DOHC DI-VCT I6	4.0L DOHC DI-VCT TURBO I6	
Applicable models	Falcon Ute, XR6		Falcon Ute, XR6	XR6 Turbo	
Engine size (cc)	3984		3984	3984	
Compression ratio	10.3:1		12:1	8.8:1	
Maximum power (DIN)	195kW @ 6000rpm		198kW @ 5000rpm	270kW @ 5250rpm ¹	
Maximum torque (DIN)	391Nm @ 3250rpm		409Nm @ 3250rpm	533Nm @ 2000rpm – 4750rpm ¹	
No. of valves			24		
Bore x stroke			92.25 x 99.31mm		
Fuel management system	Sequential multipoint electronic fuel injection		Liquid phase injection	Sequential multipoint electronic fuel injection	
Engine management	Powertrain control module incorporating electronic throttle control				
Transmission ratios	6-speed manual	6-speed auto	6-speed auto	6-speed manual	6-speed auto
1st	3.36	4.17	4.17	2.98	4.17
2nd	2.07	2.34	2.34	1.78	2.34
3rd	1.35	1.52	1.52	1.30	1.52
4th	1.00	1.14	1.14	1.00	1.14
5th	0.71	0.87	0.87	0.71	0.87
6th	0.57	0.69	0.69	0.55	0.69
Reverse	3.28	3.40	3.40	2.90	3.40
Differential	Manual	Auto	Auto	Manual	Auto
Drive ratio	3.45:1	2.73:1	2.73:1	3.73:1	2.73:1
Fuel					
Fuel tank capacity (L)	81		86	81	
Recommended fuel	ULP or PULP E10 compatible		LPG only	ULP or PULP E10 compatible	
Electrical/clutch					
Battery			54Ah		
Clutch type (manual only)	Self-adjusting diaphragm		–	Self-adjusting diaphragm	
Diameter (manual only)	254mm		–	290mm	
Maximum braked towing capacity ²					
Manual	1200Kg ^{3,4}		–	1600Kg ^{3,4}	
Automatic			2300Kg ^{4,5}		
Brakes					
Front brakes	Standard vented disc brakes with twin piston caliper (performance brakes on XR6 Turbo)				
Rear brakes	Standard solid disc brake with single piston caliper				
Anti-lock Braking System (ABS)	ABS with Electronic Brakeforce Distribution (EBD)				
Dynamic Stability Control (DSC)	Dynamic Stability Control (DSC) incorporates Emergency Brake Assist (EBA) and ABS with Electronic Brakeforce Distribution (EBD)				

Specifications and options

Exterior dimensions (mm)	Falcon Ute C/C ⁶	Falcon Ute SSB	XR6 C/C ⁶	XR6 SSB	XR6 Turbo SSB
Overall length	5391	5105	5397	5130	5130
Overall width ⁷	1897	1934	1897	1934	1934
Wheelbase	3104	3104	3104	3104	3104
Front track	1583	1583	1583	1583	1583
Rear track	1583	1583	1583	1583	1583
Front overhang	951	951	957	957	957
Rear overhang	1336	1050	1336	1069	1069
Interior dimensions (mm)					
Front headroom	1026	1026	1026	1026	1026
Front legroom	1073	1073	1073	1073	1073
Front shoulder room	1523	1523	1523	1523	1523
Front hiproom	1486	1486	1486	1486	1486
Luggage volume behind seats (L)	235	235	235	235	235
Cargo dimensions (mm)					
Suspension type	1-tonne	¾-tonne	1-tonne	Sports	Sports
Floor level load length	2209	1843	1843	2209	1843
Belt level load length	2209	1843	1843	2209	1843
Wheelhouse cargo width	1804	1224	1224	1804	1173
Tailgate opening width	1804	1356	1356	1804	1356
Liftover height	969	728	789	835	688
Cargo depth	240	442	442	240	442

1. Power and torque figures measured using premium unleaded fuel (95 RON). 2. Figures quoted are for braked trailers. Subject to State and Territory regulations. 3. When fitted with Genuine Ford towbar. Subject to state and territory regulations. 4. Towball download and rear axle limits must not be exceeded. Please refer to your Ford Dealer for advice. 5. When fitted with a Genuine Ford heavy duty towpack and load levelling kit. Subject to state and territory regulations. 6. Cab Chassis dimensions quoted with optional factory fitted tray. 7. Excludes exterior side mirrors. 8. Kerb mass and payload maximum values are approximate only. Kerb mass quoted includes full tank of fuel, without occupants or luggage/cargo and with all standard equipment (plus automatic climate control where not standard). 9. Payload (maximum) = GVM (Gross Vehicle Mass) minus the kerb mass. 10. Payload is defined as the combined value inclusive of occupants, cargo, added options, additional structures and towball download when towing. 11. For petrol engine with optional automatic transmission, add 5kg to kerb mass. For optional EcoLPi engine, add 72kg to kerb mass.

Specifications and options (continued)

Vehicle masses ⁸⁻¹⁵ . (kg)	Falcon Ute C/C ⁶ .	Falcon Ute SSB	XR6 C/C ⁶ .	XR6 SSB	XR6 Turbo SSB		
Suspension type	1-tonne	¾-tonne	1-tonne	Sports	1-tonne	Sports	Sports
GVM	2820	2510	2820	2325	2820	2325	2355
Kerb mass (manual transmission)	1606	1747	1757	1600	1615	1765	1810
Payload (maximum) (manual)	1214	763	1063	725	1205	560	545
Front axle load (maximum)	1165	1165	1165	1165	1165	1165	1165
Rear axle load (maximum)	1700	1380	1700	1240	1700	1240	1240
Tailgate load rating (maximum)	–	500	500	–	–	500	500
GCM							
- 1200kg towing	3900	3590	3900	3405	3900	3405	3435
- 1600kg towing	4260	3950	4260	3765	4260	3765	3795
- 2300kg towing	4890	4580	4890	4395	4890	4395	4425
Minimum turning circle (m)							
Diameter (kerb-to-kerb)	11.8	11.8	11.8	11.8	11.8	11.8	11.8
Engine and transmission							
4.0L DOHC DI-VCT I6	S	S	S	S	S	–	–
6-speed manual transmission	S	S	S	S	S	–	–
ZF 6-speed automatic transmission with sequential sports shift	O	O	O	O	O	–	–
ZF 6-speed automatic column shift transmission ¹⁶	O	O	–	–	–	–	–
4.0L DOHC DI-VCT TURBO I6	–	–	–	–	–	S	S
6-speed manual transmission	–	–	–	–	–	–	S
ZF 6-speed automatic transmission with sequential sports shift	–	–	–	–	–	–	O
EcoLPI 4.0L DOHC DI-VCT I6 (Dedicated LPG)	O	O	O ¹⁷	O ¹⁷	O ¹⁷	–	–
ZF 6-speed automatic transmission with sequential sports shift	S	S	S	S	S	–	–
ZF 6-speed automatic column shift transmission ¹⁶	O	O	–	–	–	–	–
Ride and handling							
Virtual Pivot Control Link front suspension	S	S	S	S	S	S	S
Hotchkiss rear suspension	S	S	S	S	S	S	S
¾-tonne suspension	–	S	–	–	–	–	–
1-tonne suspension	S	O	O	–	–	–	–
Sports suspension	–	–	–	S	S	S	S
Limited Slip Differential (LSD)	S ¹⁸ /O ¹⁹ .	S ¹⁸ /O ¹⁹ .	S	S	S	S	S
16" x 6.5" silver steel wheel (rated 1-tonne) ²⁰ .	S	S	–	–	–	–	–
16" x 7" 5-spoke alloy wheel (rated 1-tonne) ²⁰ .	A ²¹ .	A ²¹ .	O ²² .	–	–	–	–
215/60 R16 (1-tonne) tyres	S	O ²² .	O ²² .	–	–	–	–
215/60 R16 tyres	–	S	–	–	–	–	–
18" x 8" XR 5-spoke alloy wheels - 245/40 R18 tyres ²⁰ .	–	–	S	S	S	S	S
19" x 8" XR 10-spoke alloy wheel - 245/35 R19 tyres ²⁰ .	–	–	–	P	P	P	P
Steel spare wheel ²³	S	S	S	S	S	S	S
Exterior							
Prestige paint	O	O	O	O	O	O	O
Projector headlamps	–	–	S	S	S	S	S
XR front bumper	–	–	S	S	S	S	S
Alloy sports bar	–	–	–	S	S	S	S
Sports side skirts	–	–	S	S	S	S	S
Sports rear bumper	–	–	–	S	S	S	S
Fog lamps	–	–	S	S	S	S	S
Body colour mirrors	–	–	S	S	S	S	S
Wiring facility for cargo lamp	S	S	S	S	S	S	S
Cargo bedliner	–	S	–	S	S	S	S
Flush fit soft tonneau cover	–	A	–	S	S	S	S
Aluminium tray	O	–	O	–	–	–	–
Adjustable tie-down hooks	–	S	–	S	S	S	S
Instrumentation and controls							
Human Machine Interface (HMI) with Interior Command Centre (ICC) with monochrome display	S	S	–	–	–	–	–
Human Machine Interface (HMI) with Premium Interior Command Centre (ICC) with 8" colour touch screen	O	O	S	S	S	S	S
Multi-function display including distance to empty, average speed, outside air temperature, average fuel consumption, speed warning	S	S	S	S	S	S	S

S = Standard. O = Optional. P = Part of optional pack. – = Not available. A = Accessory available at any time.

12. When optional 19" wheels and tyres specified, reduce GVM, payload and rear axle load maximum by 70kg. 13. When optional factory aluminium trays specified, add 120kg to kerb mass. 14. Front and rear axle load limits must not be individually exceeded. The combined weight of the fully loaded vehicle and trailer must not exceed the GCM. GVM must not be exceeded. 15. Refer to Owner's Manual for full vehicle mass details. 16. 4-way power driver's seat not available with automatic column shift. 17. Optional EcoLPI engine increase front ride by 25mm when sports suspension is specified. 18. Standard on Falcon Ute with manual transmission. 19. Optional on Falcon Ute with automatic transmission. 20. Set of four. 21. Wheels and tyres sold separately when Dealer fit. 22. When optional 1-tonne suspension is specified. 23. Vehicles fitted with 16"/17" wheels come with a 16" steel spare wheel. Vehicles fitted with 18"/19" wheels come with a 17" steel spare wheel. Vehicles with 1-tonne suspension come with a 1-tonne rated steel spare wheel. If spare wheel, rim or tyre size differs from the other wheels fitted, the vehicle should be driven with caution and the standard wheel and tyre fitted as soon as possible.

Specifications and options (continued)

Instrumentation and controls (continued)	Falcon Ute C/C	Falcon Ute SSB	XR6 C/C	XR6 SSB	XR6 Turbo SSB
Cruise control with steering wheel mounted controls	S	S	S	S	S
Steering wheel mounted audio controls	S	S	S	S	S
Sports leather wrapped steering wheel	-	-	S	S	S
Comfort and convenience					
Single-zone automatic climate control	O	O	S	S	S
Dual-zone automatic climate control	-	-	-	P	P
Power windows	S	S	S	S	S
Automatic headlamps ON/OFF feature	S	S	S	S	S
Power adjustable side mirrors	S	S	S	S	S
Alloy pedal covers	-	-	S	S	S
Carpet floor covering	S	S	S	S	S
Driver/passenger reading lamps	S	S	S	S	S
Centre console bin with lid ²⁵	S	S	S	S	S
Lockable glove box	S	S	S	S	S
Remote keyless entry	S	S	S	S	S
Seating					
Cloth trim seats	S	S	-	-	-
Fixed centre seat with lap/sash seatbelt ²⁶	O	O	-	-	-
Cloth trim sports seats	-	-	S	S	S
Leather trim sports seats	-	-	O	O/P	O/P
4-way power driver's seat ²⁵	S	S	S	S	S
Adjustable driver's seat lumbar support	S	S	S	S	S
Adjustable passenger's seat lumbar support	-	-	S	S	S
Quick-tilt forward seats	S	S	S	S	S
Audio and communication					
Standard audio system with monochrome display, AM/FM radio, single slot CD and 2 speakers	S	S	-	-	-
Prestige audio system with 8" colour touch screen, AM/FM radio, single slot CD and 6 speakers (total 112 watts)	O	O	S	S	S
Premium audio system with AM/FM radio, single slot CD and 8 speakers (total 112 watts)	-	-	-	P	P
MP3 CD capability	S	S	S	S	S
3.5mm auxiliary audio input	S	S	S	S	S
Bluetooth® mobile phone integration ²⁷	S	S	S	S	S
iPod integration ²⁸	S	S	S	S	S
USB integration	S	S	S	S	S
Satellite Navigation	-	-	-	P	P
Safety and security					
Intelligent Safety System	S	S	S	S	S
Driver and front passenger airbags	S	S	S	S	S
Side head/thorax airbags	S	S	S	S	S
Pyrotechnic seatbelt buckle pretensioners	S	S	S	S	S
Advanced restraints module	S	S	S	S	S
Crash severity sensor	S	S	S	S	S
Driver's seat position sensor	S	S	S	S	S
Beltminder™ system	S	S	S	S	S
Dynamic Stability Control incorporating: Traction Control, Emergency Brake Assist (EBA), Anti-lock Braking System (ABS) and Electronic Brakeforce Distribution (EBD)	S	S	S	S	S
Driver fatigue warning	S	S	S	S	S
Central locking	S	S	S	S	S
Towing					
Towbar - 1600kg rated	O ²⁹ /A	O ²⁹ /A	O ²⁹ /A	O ²⁹ /A	O ²⁹ /A
Optional packs					
XR Luxury Pack					
Leather trim sports seats, satellite navigation with Suna Traffic Channel ²⁷ , 19" x 8" 5 spoke alloy wheels with 245/35 R19 tyres ³⁰ , dual-zone automatic climate control and premium audio system with 8 speakers	-	-	-	O	O

S = Standard. O = Optional. P = Part of optional pack. - = Not available. A = Accessory available at any time.

²⁵ Not available with optional automatic column shift transmission. ²⁶ Must specify optional automatic column shift transmission. ²⁷ Bluetooth® is a registered trademark of Bluetooth SIG Inc., and is used under licence. Customers should consult their Ford Dealer on the ability of their mobile phone handset to integrate with the Bluetooth® system prior to making a purchase decision. ²⁸ iPod is a trademark of Apple Inc. Please refer to www.ford.com.au for iPod compatibility. ²⁹ Towball sold separately when factory fitted. ³⁰ Vehicle must be fitted with Bluetooth®. Ford has an arrangement to provide the Suna Traffic Channel broadcast for a minimum of 5 years from the time of vehicle manufacture. Coverage includes Melbourne, Sydney, Brisbane, Adelaide, Perth and Gold Coast metropolitan areas. Refer to www.sunatrafic.com.au for full details.

Styleside Box

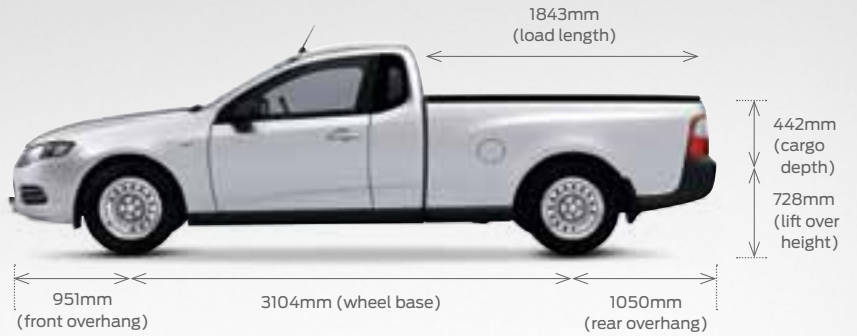

Cab Chassis

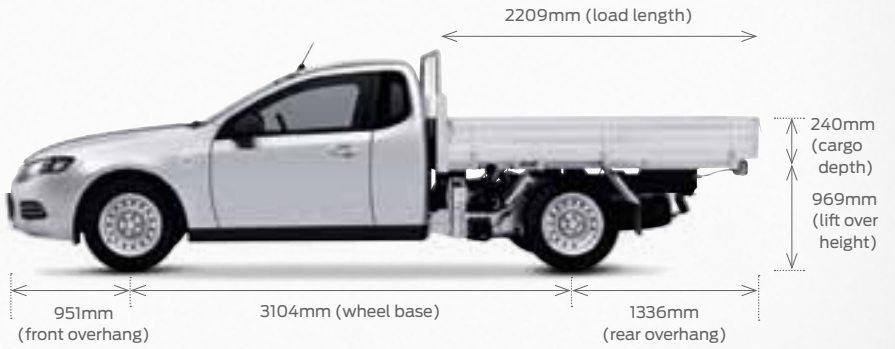

*Excludes side mirrors.



Quality

We design and build your Ford to feel as good after many years of service as it did the day you picked it up. And to drive just as beautifully, too.



Sustainability

Using advanced technology, we're committed to creating vehicles with improved fuel economy, reduced CO₂ emissions and a lower overall cost of ownership.



Safety

Ford's Intelligent Protection System uses sophisticated technology designed to help prevent an accident and, if one should happen, to help protect you.



Smart

Vehicles with smart, intuitive technologies designed to connect you to your world and many clever solutions that make life a little easier.

Speak to your Ford Dealer today about how we can help you make the most out of your vehicle ownership experience.

3 year/100,000km new car warranty.#

For three years or 100,000km, whichever comes first, your Ford is covered against any defects in factory materials or workmanship. This also applies to Genuine Ford Accessories you may have had fitted before you took delivery.

5 year warranty against perforation corrosion.#

It's reassuring to know that the original body of your gleaming new Ford is guaranteed against perforation corrosion for the first five years of its life. If perforation corrosion occurs, we'll fix it for free.

myFord Warranties and Insurance.

When you first turn the key of your brand new Ford you want to do so without a care in the world. Our range of myFord products gives you that extra peace of mind. For more information about myFord Warranties and Insurance, visit your participating Ford Dealer for further details on the plans that best suit your needs. Terms, conditions and eligibility criteria apply.

12 months/15,000km service intervals.

Under normal driving conditions service intervals are 12 months or 15,000km, whichever occurs first.

Running a fleet?

Our Ford Fleet team is available to assist fleet customers with information on Ford products and services. Call 1300 13 13 30 or email askfleet@ford.com

Want to contact us?

For answers to your questions, or help with any concern, contact our Customer Relationship Centre on 13 FORD (13 3673) or email customers@fordcrc.com.au

Visit us on the web.

If you want more information on Ford or our entire product range, visit us at ford.com.au

myFord Capped Price Servicing.

Your new Ford vehicle now gives you access to myFord Capped Price Servicing, which means it makes even more sense to have your Ford looked after by the people who know your Ford back to front, inside and out. With myFord Capped Price Servicing, Ford will publish the maximum price you will pay for a standard A or B logbook service at participating Authorised Ford Dealers for all vehicles built from 2007 up to 6 years or 105,000 kilometres, whichever comes first.

In addition, when vehicles are serviced under myFord Capped Price Servicing, Retail and Small Business Customers will also receive 12 months myFord Standard Roadside Assistance (RRP \$90).

For more details visit your local Ford Dealer or visit www.ford.com.au/myfordcps for full terms and conditions.



myFord Roadside Assistance.

Our commitment to your complete satisfaction plays a major role in everything we do. That is why we provide 1 year myFord Roadside Assistance for all Ford Falcon Ute models. Wherever and whenever you need emergency roadside assistance, help is available 24 hours a day, 365 days a year. If your vehicle breaks down and cannot be repaired, we will organise to transport your vehicle to the nearest Ford Dealer or approved service centre for repair. myFord Roadside Assistance is valid for 1 year from the vehicle's first registration.

Click to Request



Quote



Hot Deals



Test Drive

#Conditions and exclusions apply. For more information visit ford.com.au/newvehiclewarranties

This brochure details specifications and features of the FG Falcon Ute MkII. Please consult your Ford Dealer for the most recent specifications and availability information.

This brochure is designed to provide you with a general introduction to the Ford Products (including available optional equipment) referred to, and should be read in conjunction with the latest specification sheet. Because of changes in conditions and circumstances Ford* reserves the right, subject to all applicable laws, at any time, at its discretion, and without notice, to discontinue or change the features, designs, materials, colours and other specifications and the prices of its products, and to either permanently or temporarily withdraw any such products from the market without incurring any liability to any prospective purchaser or purchasers. The latest specification sheet should be referred to for information on the availability, ordering and use of optional equipment. Always consult an authorised Ford Dealer for the latest information with respect to features, specifications, prices, optional equipment and availability before deciding to place an order.

*FORD MOTOR COMPANY OF AUSTRALIA LIMITED. (A.B.N. 30 004 116 223) Registered Office: 1735 Sydney Road, Campbellfield, Victoria 3061, Australia. Printed October, 2012. FUTE0026. FG Falcon Ute MkII Brochure. FRD001537.



Go Further

ford.com.au