	<b>VOLUME</b>  3	GROUP Fuel	MODEL Sedona, Sorento Optima, Amanti
		NUMBER 006	DATE December 2004
<b>TECHNICAL SERVICE BULLETIN</b>			
SUBJECT: ENHANCED DIAGNOSIS AND REPAIR FOR P0446/P2422			

This bulletin provides information relating to diagnostic trouble code (DTC) P0446/P2422 (Scanner Description: EVAP System: Vent Control) for all Sedona, Sorento, Amanti and Optima (2.4L only) vehicles. The DTC P0446/P2422 sets when the fuel tank pressure sensor measures excessive vacuum in the fuel tank. P0446/P2422 is NOT related to a system leak. The Hi-Scan EVAP LEAK CHECK will NOT check for DTC P0446/P2422.

**NORMAL SYSTEM OPERATION:**

In an evaporative emissions system, fuel vapors and air in the charcoal canister are drawn into the intake manifold through the canister purge valve. The vapor/air drawn from the charcoal canister is replenished by fresh air being drawn through the EVAP air filter and canister close valve. Normally, there is a small but measureable amount of vacuum at the fuel tank pressure sensor during purging.

During the system leak check (the vehicle must be driving at a steady speed with engine RPM over 1800), the canister close valve shuts and purging occurs until the system is drawn to approximately 1.8 volts (measured at the fuel tank pressure sensor). The vacuum will remain at the specified value for up to 30 seconds (depending on the fuel level). This is NORMAL operation, and should NOT be confused with the diagnostic procedures described later.

In a system that sets P0446/P2422, the amount of vapors being purged from the canister is greater than the volume of fresh air entering into the canister. This causes the canister to build up vacuum. When the canister increases in vacuum, the remainder of the system (fuel tank, hoses, separator, etc.) will also increase in vacuum. The fuel tank pressure sensor measures and reports the vacuum level (in volts) to the ECM. If the vacuum level reaches beyond the ECM threshold, P0446/P2422 is set into ECM memory. If this condition occurs on two consecutive drive cycles, then the MIL will illuminate.

**EVAPORATIVE EMISSION COMPONENTS:**

1. Canister Close Valve (CCV)
2. Fuel Tank Pressure Sensor (FTPS)
3. Canister Purge Valve
4. Fuel Cut Valve
5. CCV Air Filter (Sedona shown)
6. Charcoal Canister

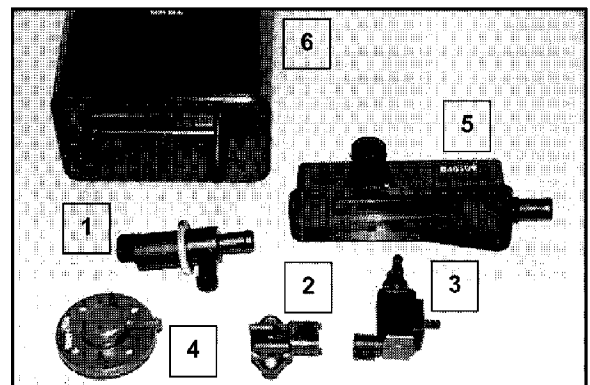

Note: Sedona Components Shown

**File Under: Fuel**

- Circulate To:**
- |  |   |   |
|--|---|---|
| <input checked="" type="checkbox"/> General Manager    | <input checked="" type="checkbox"/> Service Manager | <input checked="" type="checkbox"/> Parts Manager     |
| <input checked="" type="checkbox"/> Service Advisor(s) | <input checked="" type="checkbox"/> Technician(s)   | <input checked="" type="checkbox"/> Body Shop Manager |
|  |   | <input checked="" type="checkbox"/> Fleet Repair      |

**SUBJECT:**

## ENHANCED DIAGNOSIS AND REPAIR FOR P0446/P2422

**Diagnostic Aid:**

**CCV Clogging Error (P0446/P2422)** is detected when the fuel tank pressure goes below the specified threshold for longer than 10 seconds, the DTC will then be stored in the ECM. See attached chart threshold values, compare against recorded values.

**Evaporative Test Set-up:**

- Perform a visual inspection of the related electrical connector and terminals, vacuum hoses and routings. Correct any loose pin tension, cracked, disconnected or kinked hoses before proceeding.
- Install BOB to monitor the FTPS signal voltage.
- Measure the FTPS voltage, normal voltage should be between 2.2~2.8 DCV with no pressure or vacuum in the fuel tank with Key-On, Engine Off.
- The engine coolant temperature must be above 140 degree F before starting the engine. Failure to do so may result in erratic canister close valve operation during the test.

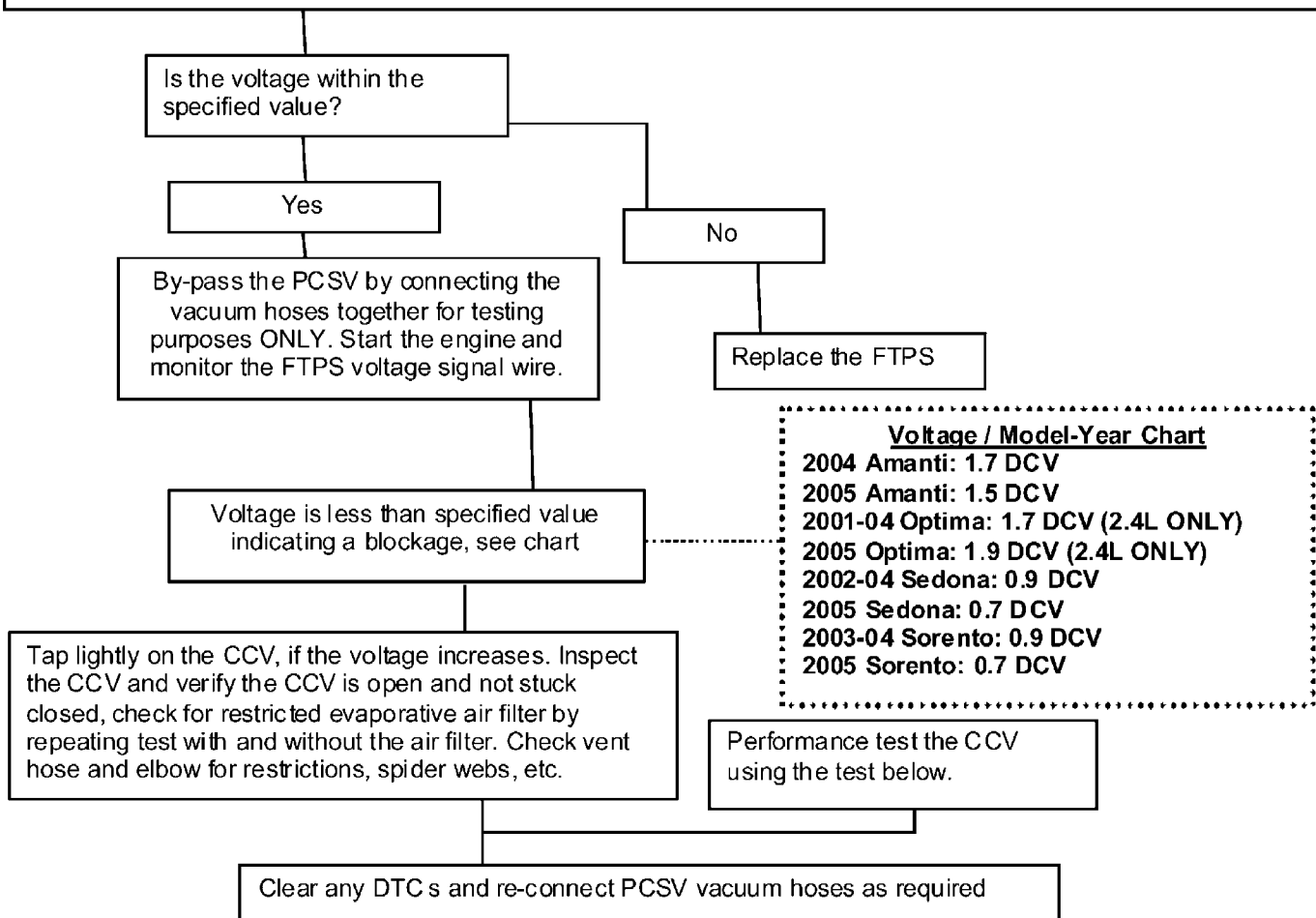

**Performance Test CCV:**

Apply battery voltage and ground to CCV, if valve does not hold pressure or vacuum when energized, replace CCV.

**Component Resistance Test:**

PSCV - 30~40 Ohms @ 68 degree F  
 CCV - 23~26 Ohms @ 68 degree F

SUBJECT:

**ENHANCED DIAGNOSIS AND REPAIR FOR P0446/P2422**

## SORENTO AND SEDONA TANK PRESSURE SENSOR CHART

Fuel Tank Pressure Voltage	Fuel Tank Pressure in Millibar	Fuel Tank Pressure in mmAq
0.50	-37.6	-381
0.60	-35.5	-362
0.70	-33.6	-343
0.80	-31.7	-324
0.90	-29.9	-305
1.00	-28.0	-286
1.10	-26.1	-267
1.20	-24.3	-248
1.30	-22.4	-229
1.40	-20.4	-209
1.50	-18.6	-190
1.60	-16.7	-171
1.70	-14.9	-152
1.80	-13.0	-133
1.90	-11.1	-114
2.00	-9.3	-95
2.10	-7.4	-76
2.20	-5.5	-57
2.30	-3.7	-38
2.40	-1.8	-19
2.50	0.0	0
2.60	1.8	19
2.70	3.7	38
2.80	5.5	57
2.90	7.4	76
3.00	9.3	95
3.10	11.1	114
3.20	13.4	133
3.30	14.9	152
3.40	16.7	171
3.50	18.6	190
3.60	20.4	209
3.70	22.4	229
3.80	24.3	248
3.90	26.1	267
4.00	28.0	286
4.10	29.9	305
4.20	31.7	324
4.30	33.6	343
4.40	35.5	362
4.50	37.6	381

Sorento/Sedona  
05MY Threshold\*

Sorento/Sedona  
02 - 04MY  
Threshold\*

\* Dark grey area shows restriction and clogging concerns.

SUBJECT:

**ENHANCED DIAGNOSIS AND REPAIR FOR P0446/P2422**

## AMANTI AND OPTIMA TANK PRESSURE SENSOR CHART

Fuel Tank Pressure Voltage	Fuel Tank Pressure in Millibar	Fuel Tank Pressure in mmAq	
0.50	-66.9	-683	
0.60	-63.6	-649	
0.70	-60.3	-615	
0.80	-56.9	-581	
0.90	-53.6	-547	
1.00	50.2	-512	
1.10	-46.8	-478	
1.20	-43.5	-444	
1.30	-40.2	-410	
1.40	-36.8	-376	
1.50	-33.5	-342	← Amanti/Optima 05MY Threshold*
1.60	-30.1	-307	
1.70	26.7	273	← Amanti 04MY Threshold*
1.80	-23.4	-239	
1.90	20.0	205	← Optima (2.4L only) 01 - 04MY Threshold*
2.00	-16.7	-171	
2.10	-13.4	-137	
2.20	-10.0	-102	
2.30	-6.6	-68	
2.40	-3.3	-34	
2.50	0.0	0	
2.60	3.3	34	
2.70	6.6	68	
2.80	10.0	102	
2.90	13.4	137	
3.00	16.7	171	
3.10	20.0	205	
3.20	23.4	239	
3.30	26.7	273	
3.40	30.1	307	
3.50	33.5	342	
3.60	36.8	376	
3.70	40.2	410	
3.80	43.5	444	
3.90	46.8	478	
4.00	50.2	512	
4.10	53.6	547	
4.20	56.9	581	
4.30	60.3	615	
4.40	63.6	649	
4.50	66.9	683	

\*Grey area shows restriction and clogging concerns.

SUBJECT:

## ENHANCED DIAGNOSIS AND REPAIR FOR P0446/P2422

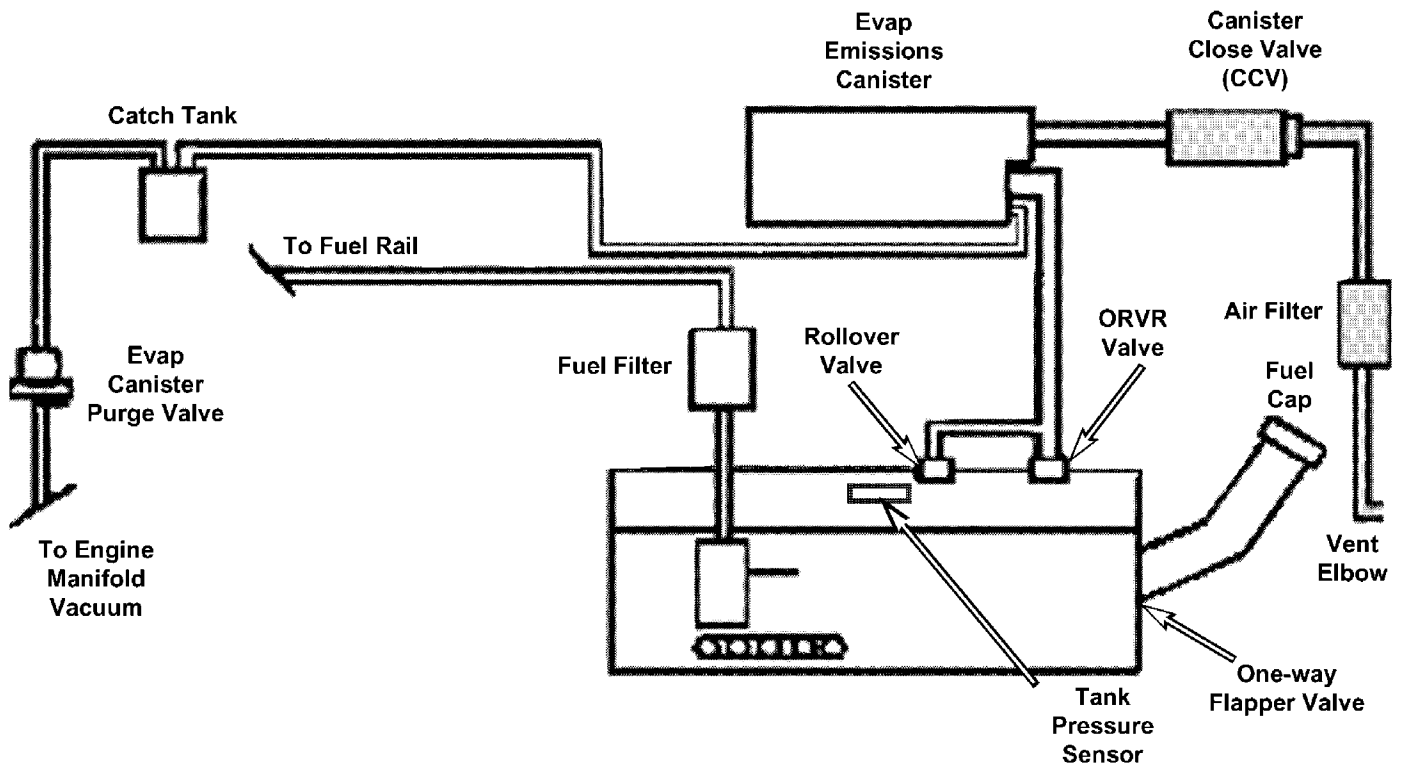

Note: Sorento/Sedona System Shown

- Restrictions in the shaded areas will set a DTC P0446 or P2422.
- Inspect Canister Close Valve (CCV) for proper operation.
- Inspect Vent Vacuum hoses for restrictions, spider webs, cocoon nests, kinks, etc.
- Inspect the Fuel Tank Pressure Sensor (FTPS) atmospheric pressure port for restrictions, shipping cap.
- Inspect air filter for clogging, use charts on pages 3 and 4 to determine filtering ability.