



**Technical Service  
Information Bulletin**

January 7, 2004

Title:

# STEERING COLUMN NOISE

Models:

'98 - '00 LS 400 & '01- '04 LS 430

STEERING  
ST001-04

**Introduction** Some LS 400 and LS 430 vehicles may experience steering column noise due to insufficient torsional strength of the telescopic steering column cable. The cable has been replaced with a universal joint to prevent steering column noise. Follow the repair procedures described in this bulletin to improve the condition.

- Applicable Vehicles**
- 1998 - 2000 model year **LS 400** vehicles.
  - 2001 - 2004 model year **LS 430** vehicles.

MODEL	APPLICABLE VEHICLE VIN RANGE	REPLACE PARTS*
'99 - '00 LS 400	JT8BH28F#X0139061 to JT8BH28F#Y0181876	A and B
'01 - '02 LS 430	JTHBN30F#10001067 to JTHBN30F#20059626	
'02 - '04 LS 430	JTHBN30F#20059627 to JTHBN36F040141419	A

\* Refer to Parts Information Table.

**Parts Information**

PROCEDURE PARTS	PART NUMBER	PART NAME	QTY
A	45230-50020	Joint Assembly, Steering Shaft Universal	1
B	45766-60011	Support, Telescopic Steering Slider	1
	45898-60020	Bolt, Support Stopper	2

**Warranty Information**

OP CODE	DESCRIPTION	TIME	OFF	T1	T2
ST3002	Steering Shaft Universal Joint Assembly Replacement	0.9	45230-50010	44	44
ST3003	Telescopic Steering Slider Support/ Steering Shaft Universal Joint	1.0			

**Applicable Warranty\*:**

This repair is covered under the Lexus Comprehensive Warranty. This warranty is in effect for 48 months or 50,000 miles, whichever occurs first, from the vehicle's in-service date.

\* Warranty application is limited to correction of a problem based upon a customer's specific complaint.



'98 - '00  
LS 400  
Component  
Information

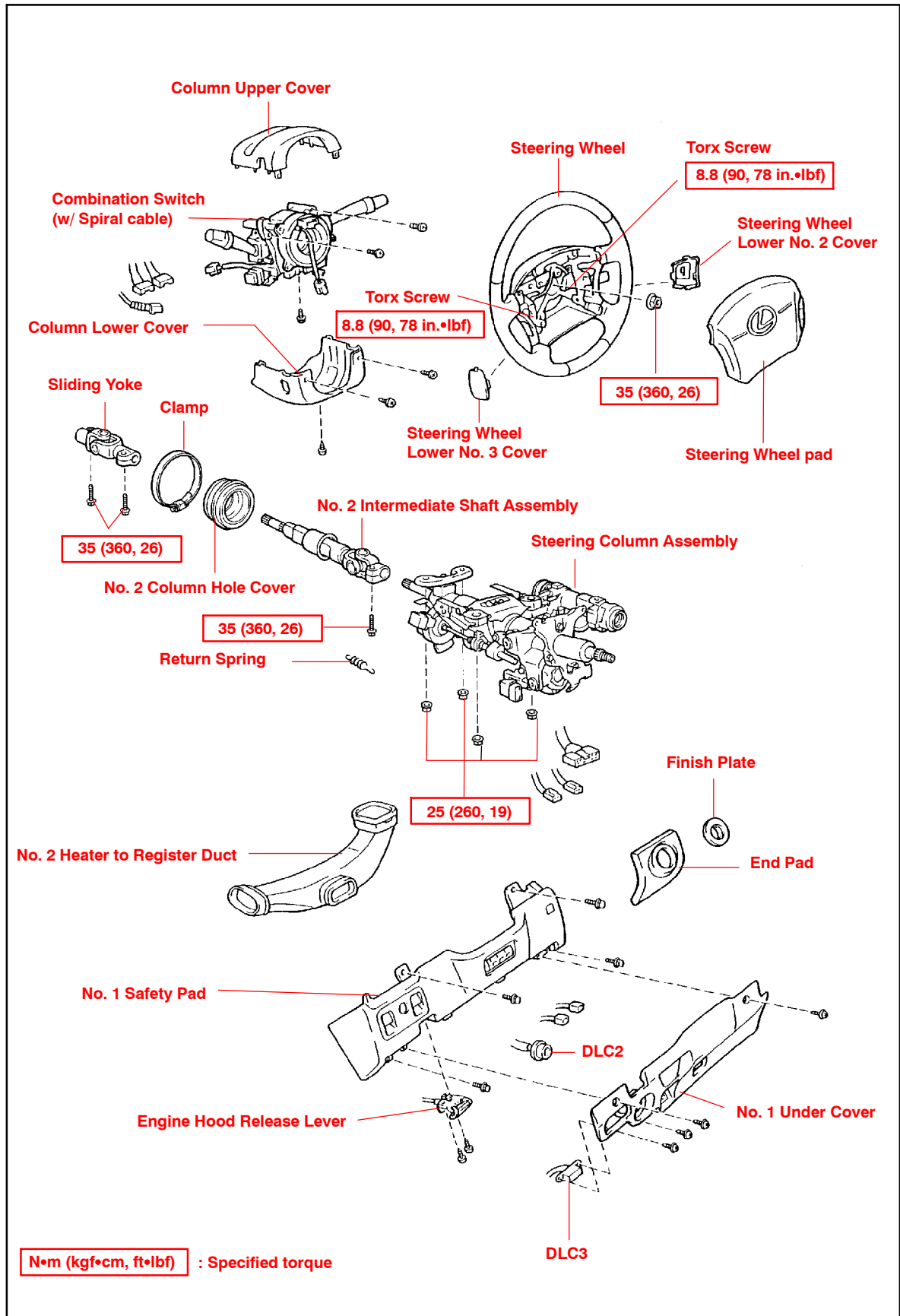

**LS 400 Trim  
Removal**

- 1. Remove No. 1 Under Cover.**
  - A. Remove the 2 screws and No. 1 under cover.
  - B. Disconnect the 2 connectors and DLC2.
  - C. Remove the 2 screws and DLC3.
  
- 2. Remove End Pad and Finish Plate.**
  
- 3. Remove No. 1 Safety Pad.**
  - A. Remove the 2 screws and disconnect the engine hood release lever.
  - B. Remove the 4 pad set bolts and No. 1 safety pad.
  
- 4. Remove No. 2 Heater to Register Duct.**
  
- 5. Remove Column Upper and Lower Covers.**

Remove the 3 screws, column upper and lower covers.
  
- 6. Turn to Page 10 for Component Repair Instructions.**

'01 - '03  
LS 430  
Component  
Information

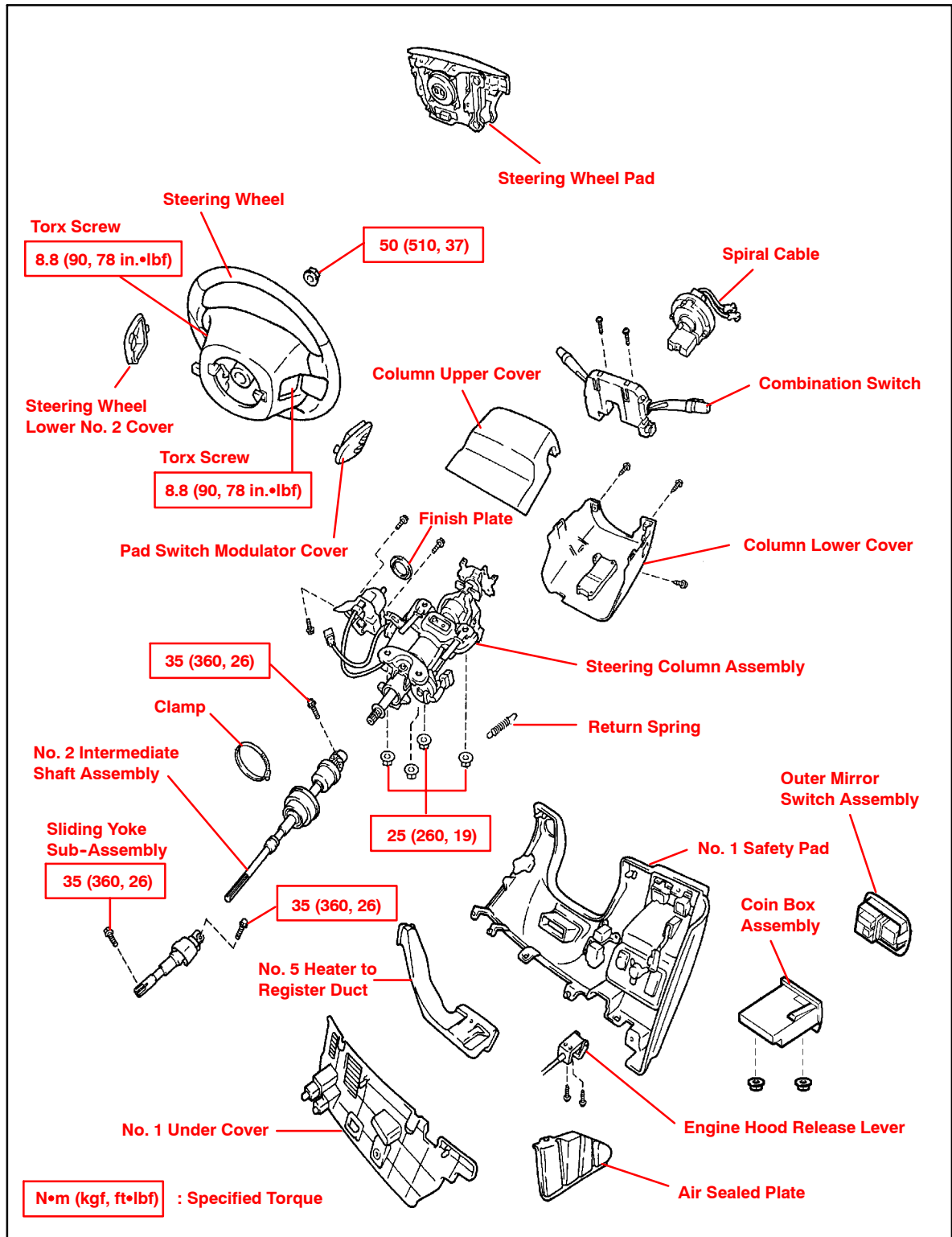

'04 LS 430  
w/knee Airbag  
Component  
Information

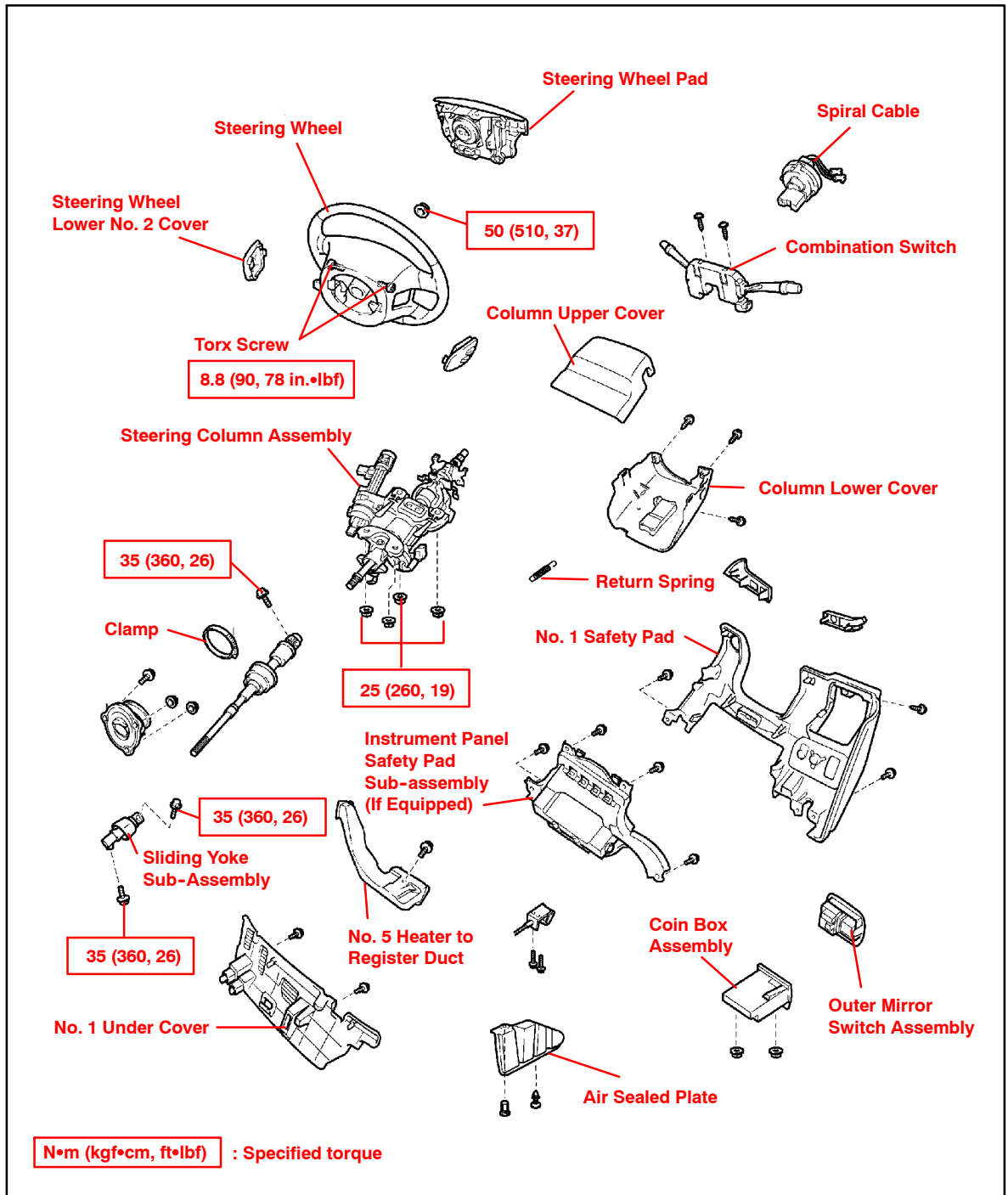

'01 - '04  
LS 430  
Trim Removal

**1. Remove Instrument Panel Under Cover Sub-assembly No. 1.**

- A. Remove the 2 screws.
- B. Disengage the 2 clips and remove the instrument panel under cover sub-assembly No. 1.
- C. Disconnect the connectors.

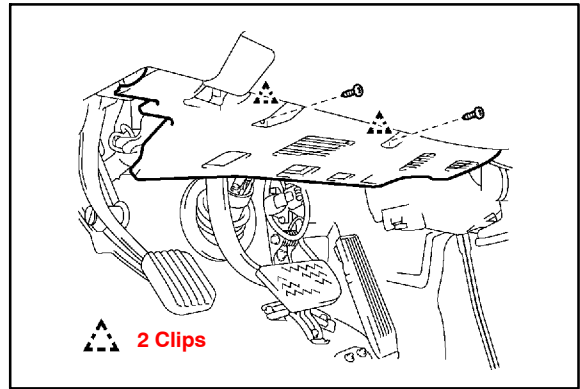

**2. Remove Coin Box Assembly.**

- A. Pull the parking brake and remove the 2 nuts from the coin box assembly.
- B. Using a molding remover, disengage the 2 claws and remove the coin box assembly.
- C. Disconnect the connector.

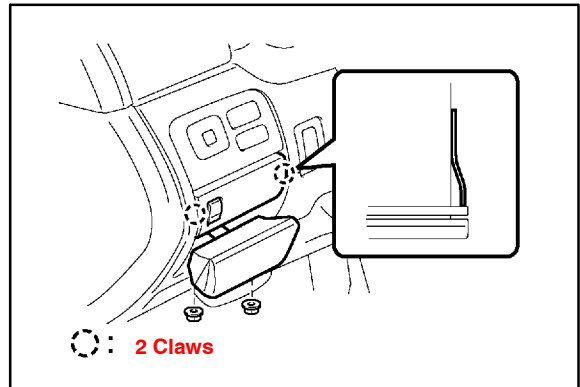

**3. Remove Outer Mirror Switch Assembly.**

- A. Using a molding remover, disengage the 2 claws and remove the outer mirror switch assembly.
- B. Disconnect the connectors.

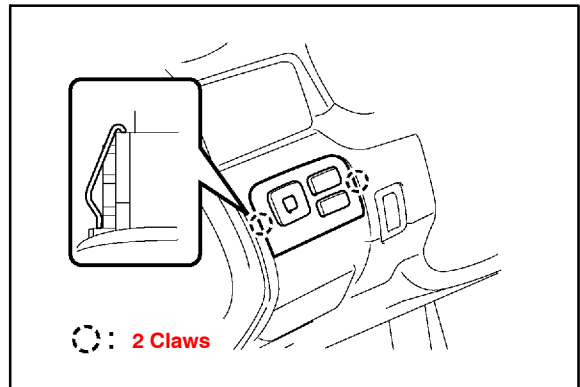

'01 - '04  
LS 430  
Trim Removal  
(Continued)

**4. Remove Instrument Cluster Finish Panel Center Lower.**

- A. Using a screwdriver, disengage the 2 claws and remove the instrument cluster finish panel center lower.
- B. Disconnect the connector.

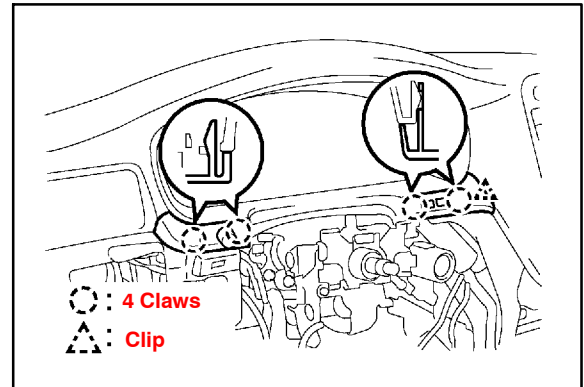

**5. Remove Instrument Cluster Finish Panel End.**

- A. Using a screwdriver, disengage the 2 claws and the clip and remove the instrument cluster finish panel center end.
- B. Disconnect the connector.

**6. Remove Instrument Panel Safety Pad Sub-assembly No. 1.**

- A. Remove the screw "A" and the 2 bolts "B."
- B. Remove the 2 bolts and the hood lock control cable assembly.
- C. Disengage the 4 clips and remove the instrument panel safety pad sub-assembly No. 1.
- D. Disconnect the connectors.

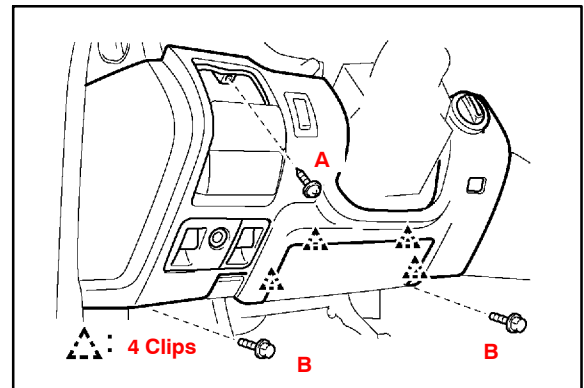

'04 LS 430  
w/Knee Airbag  
Trim Removal

**In cases of '04 LS 430 with Knee Airbag:**

**7. Remove Instrument Panel Air Bag Assembly Lower No. 1.**

- A. Disconnect the connector from the instrument panel air bag assembly lower No. 1.

**NOTE:**  
When handling the airbag connector, take care not to damage the airbag wire harness.

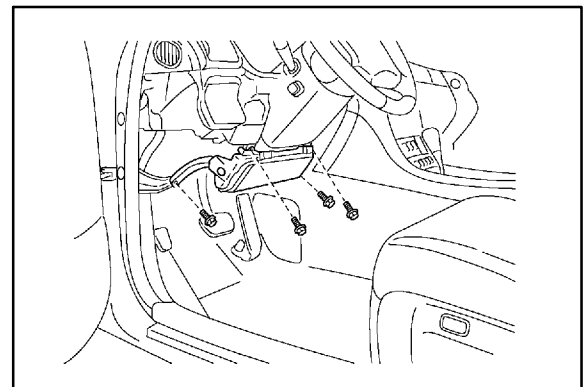

- B. Remove the 4 bolts and the instrument panel air bag assembly lower No. 1.

'04 LS 430  
w/Knee Airbag  
Trim Removal  
(Continued)

**8. Remove Steering Column Cover.**

- A. Remove the 3 screws and the steering column cover.

**NOTE:**

The illustration has the steering wheel removed to show the screw location. It is NOT necessary to remove the steering wheel for this repair.

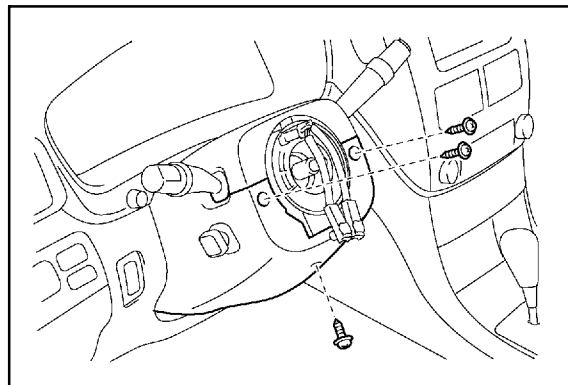



All LS 400/430  
Component  
Information  
(Continued)

All LS 400/430 Steering Shaft Component Information

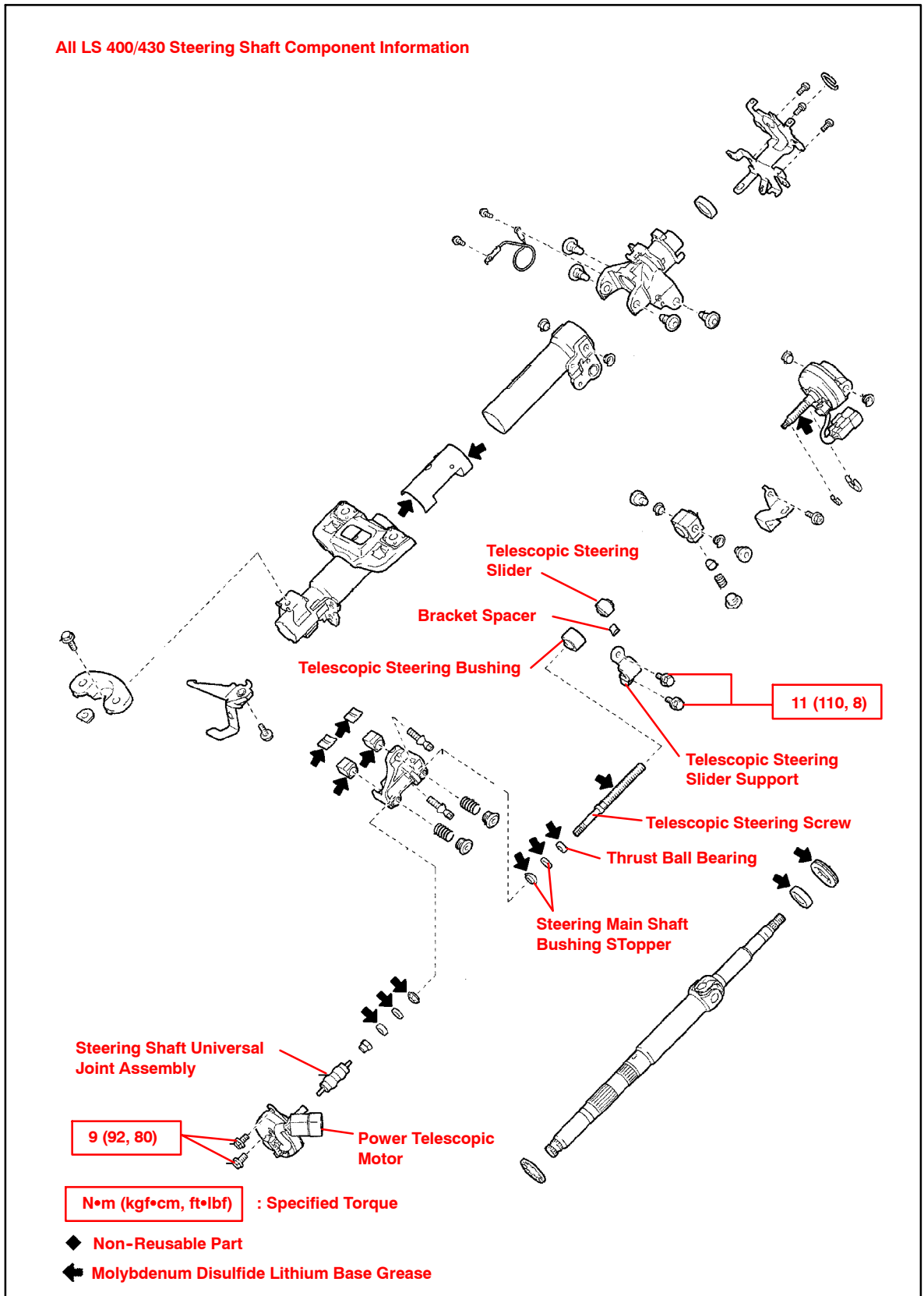

All  
LS 400/430  
Repair  
Procedure

**9. Remove Power Telescopic Motor.**

- A. Remove the 2 bolts and the power telescopic motor.

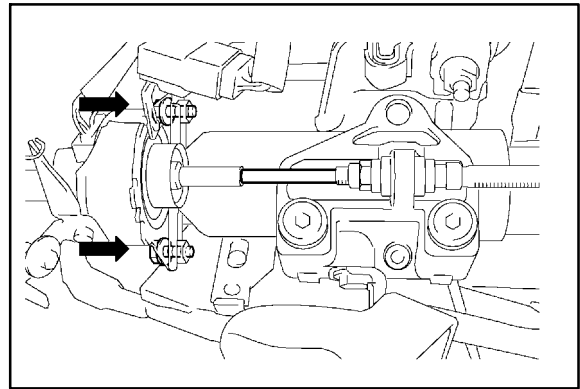

**10. Replace Telescopic Steering Support and Support Stopper Bolts.**

- A. Check the VIN.
- B. If necessary, replace the telescopic steering support and the support stopper bolts.

**Torque: 11 N•m (112 kgf•cm, 8 ft•lbf)**

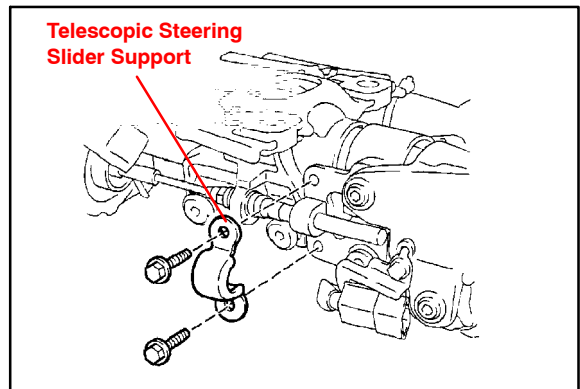

**11. Remove Telescopic Steering Column Cable Assembly.**

- A. Remove the telescopic steering column cable.

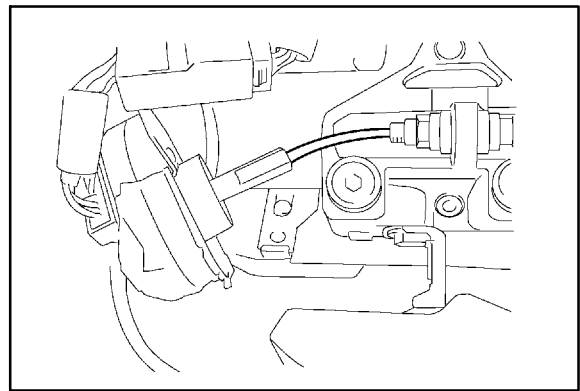

**12. Install Steering Shaft Universal Joint Assembly.**

- A. Install the steering shaft universal joint assembly.
- B. Tighten the power telescopic motor with the 2 bolts.

**Torque: 9 N•m (92 kgf•cm, 80 in.•lbf)**

**13. Install Interior Trim in Reverse Order.**

