



E-Class Coupé

Mercedes-Benz



od looks. It flexes its muscles. It has an engine which is the definition of power
which can think for itself. Way to go: the multifunction steering wheel. Talk of
command centre. Not a hint of weakness: the muscular tail end is the embodiment
of power. The rear suspension keeps your feet firmly on the ground. No doubt about it: the new E-Class
with panoramic glass roof lets it come flooding in. More of a view! See the world – the road –
through your pulse rate. And the AMG Sports package will set it racing, guaranteed! 180
km/h, rear apron and side sill panels: athletic. AMG bodystyling: unmistakable
on the carriageway. **Object of desire.** The centrifugal force is tamed: object of desire
because minutes and hours are what count. Only one thing matters here: the time you spend

Mercedes-Benz





Beauty is in the genes

Good looks run in the family – the new E-Class Coupé is living proof of this widely held belief. As early as 1956 the 220 S Coupé set a significant milestone in automotive history with its progressive technology and comfortable self-supporting chassis-body structure, not to mention its sheer elegance. These same qualities are still very much in evidence to this day: elegance is the distinguishing character trait of today's Mercedes-Benz coupés.

The 220 S Coupé is one of the forebears of the Gran Turismo, the culture of “splendid travel”. In 1958 journalists at MOTOR REVUE rejoiced: “The 220 S offers so much in terms of comfort and performance. The interior equipment is absolutely outstanding.”

As the youngest member of the Mercedes-Benz coupé family the new E-Class Coupé certainly lives up to this claim. Alongside its impressive technology it has everything it takes to be a classic right from the word go: the genes of the Mercedes-Benz coupé family.



Inspired

It exerts a magical allure. The new E-Class Coupé turns heads. It makes you want to get in. With its extroverted design and timeless good looks. With its sheer power delivery and refined handling. With its integral safety and highest-possible levels of comfort. With everything that distinguishes a Mercedes-Benz coupé: with the kind of passion that just won't loosen its grip.

At a glance | from page 6, Insight | from page 28

E-Class Coupé



Facts

Dynamism in top form: engines, transmissions, exhaust systems, AGILITY CONTROL package and Dynamic Handling package.

Drive system & chassis | from page 36

Safety down to the last detail: innovations and tried-and-tested technologies which prevent accidents from happening in the first place, reduce the consequences of an accident and support rescue procedures.

Safety | from page 46

Relax on the journey: all you need to know about the multimedia and assistance systems, air conditioning and seats.

Comfort | from page 50

A coupé with character: interior concepts, AMG Sports package designo, paintwork, standard and optional equipment, wheels and genuine accessories.

Equipment | from page 56

Figures that count: technical data and dimensions.

Facts and figures | from page 78

Star service: everything you need to know about Mercedes-Benz Centers and its sales and service outlets, the MercedesCard, Mercedes-Benz mobility and test drives.

Services | from page 81



Like a magnet!

Resistance useless

The machine has stirred. The new E-Class Coupé shows its face. It displays its good looks. It flexes its muscles. And it demonstrates style. All to get your undivided attention.





In focus: the E 350 CGI BlueEFFICIENCY with direct injection | AGILITY CONTROL package | ADAPTIVE BRAKE with HOLD function

Like a shot!

Hooked on torque

It has an engine which is the definition of power. A suspension which smooths out the road. A transmission which skips gears. A brake which can think for itself. It has it all. The only thing that's missing is a driver.

→ Page 38-45



Set the pace!

Ready to go? Once you start you won't want to stop









Way to go: the multifunction steering wheel. Talk of the town: the multimedia system with a telephone function. At your fingertips: your personal command centre.

→ Page 50

Your option: the COMAND APS multimedia system with the LINGUATRONIC voice-operated control system



E 350



CGI

D S UN 537

Full of suspense!

A strong standpoint. Not least when driving

Not a hint of weakness: the muscular tail end is the embodiment of passion. Nothing shadowy here: the LED tail lights shine brightly. No holds barred: the diffuser keeps your feet firmly on the ground. No doubt about it: the new E-Class Coupé is the stuff dreams are made of.

→ Page 42, 47





What an aura!

It has what it takes to light up your eyes

More light! Time for the sun to rise and shine – the panoramic glass roof lets it come flooding in. More of a view! See the world – the retractable side windows let you take in the scenery. More elegance! Let the dream begin.

→ Page 73

Your option: panoramic sliding glass sunroof

Like muscles!

Tangibly alluring



Your option: AMG Sports package



Sport is the muscular design. The directness of the steering. Sport is the tuning of the sports suspension. The dimensions of the light-alloy wheels. Sport is your pulse rate. And the AMG Sports package will set it racing, guaranteed!

→ Page 62-65

18-inch AMG wheels: high-sheen. Tailpipes: trapezoidal-section in a black insert. Front apron, rear apron and side sill panels: athletic. AMG bodystyling: unmistakable.

→ Page 62-65

Your option: AMG Sports package









Pulling power!

First-rate roadholding

There lies the road: its contours as yet undisclosed. You're following one line only: that of the carriageway. Your speed remains constant: only the direction changes. The centrifugal force is tamed: the Dynamic Handling package is set to "Sport". The bends in the road become your training partner. At the touch of a button.

→ Page 29, 44

Your option: Dynamic Handling package (standard for the E 500)





Non-stop!

Pleasure all the way





Forget distances. Seconds, minutes and hours are what count. Only one thing matters here: the time you spend in the new E-Class Coupé.



Even bumps in the road can be smoothed out

Roads have their highs and lows, just like the swell of the ocean. Whilst jetties are built for ships, so that they can move in shallow waters when in harbour, things are a little trickier where roads are concerned: new uneven sections and holes are constantly appearing, caused by rain, frost and construction work.

If a car is to drive as comfortably and quietly as a ship on a calm sea, its suspension has to adapt to the roads; it has to smooth them out. Mercedes-Benz has come up with the solution: the AGILITY CONTROL package. It lessens the impact of uneven sections of road by constantly setting its dampers in accordance with the surface being driven over. And at the same time it enhances the road roar and tyre vibration characteristics. This, along with the optional Dynamic Handling package, which tightens the shock absorber characteristic at the touch of a button in sports mode, sees to it that there are no obstacles to enjoying a trip in the new E-Class Coupé.

By far the most relaxing way to travel

Wild geese fly thousands of miles in their impressive V-shaped wedge formation – without any stress whatsoever. They inspired the Mercedes-Benz engineers carrying out research into how driving a car might be made even more comfortable, efficient and safe.

The result of their work comes in the shape of a system that makes journeys in the new E-Class Coupé more relaxed than ever and that can even adjust the car's distance from other vehicles according to the road and traffic conditions: the optional DISTRONIC PLUS proximity control. Short and long-range radar sensors constantly monitor the area surrounding the vehicle and regulate its speed – both in stop-and-go traffic and in the speed range up to 200 km/h.

As soon as the vehicle in front accelerates the E-Class Coupé also gently speeds up until the set speed is reached again. This makes even a longer journey stress-free, and because this driving style is particularly efficient, fuel consumption is also reduced.

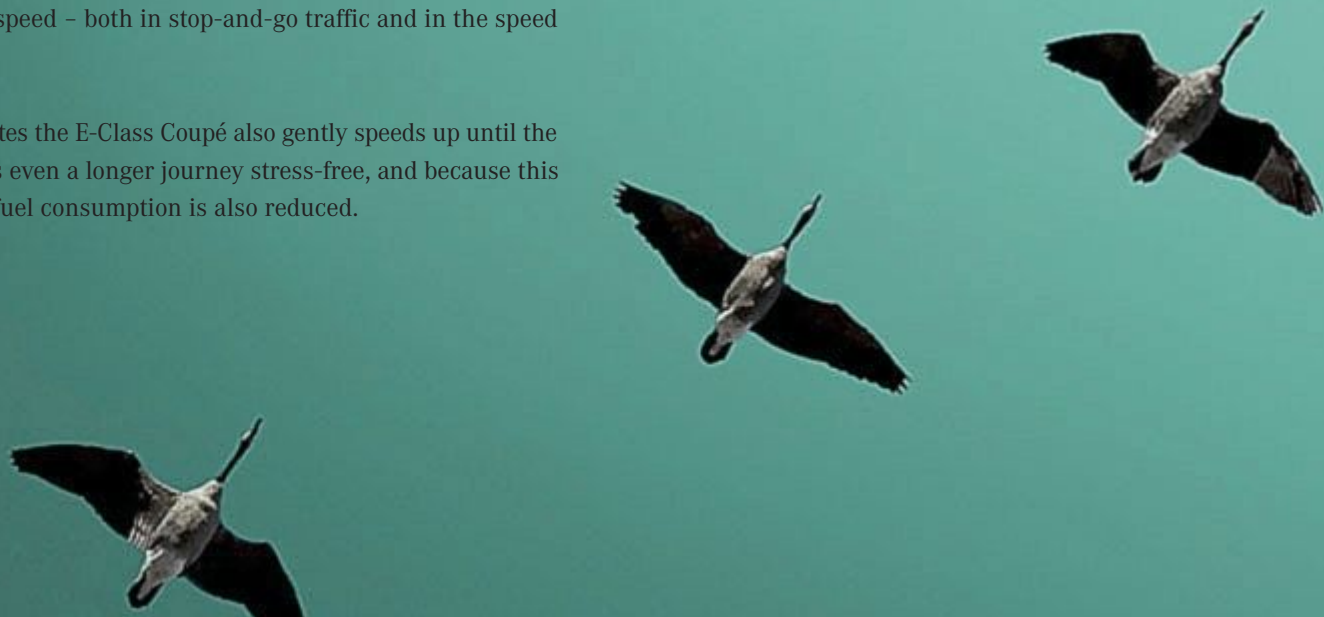





GI BlueEFFICIENCY Rated output 215/6400 kW at rpm Top speed approx. (1
ue 310/2000-4300 Nm at rpm Acceleration from 0-100 km/h 7.2 (8.1) s (m
AKE Fuel consumption l/100 km extra-urban 6.3 - 6.6 ATTENTION ASSIST
Rated torque 500/1600-1800 Tank capacity (l)/of which reserve approx. 80
7G-TRONIC Memory package Permissible gross weight (kg) 2165 (2165) D
NCY Total displacement 1796 cc Rated output (kW at rpm) 150/5500 7G-TR
(s) Top speed approx. 249 (250) km/h DISTRONIC PLUS PRE-SAFE[®] Brak
-ENTRY system **The facts.** Tyre size, front 235/45 R 17 7G-TRONIC EASY-E
CDI BlueEFFICIENCY extra-urban 5.6 combined 6.8 Tank capacity (l) 66 K

36 **TrueBlueSolutions**38 **Diesel engines**

4-cylinder

6-cylinder

40 **Petrol engines**

4-cylinder

6-cylinder

8-cylinder

42 **Exhaust systems**43 **Transmissions**

6-speed manual transmission

5-speed automatic transmission

7G-TRONIC

44 **Suspension**

AGILITY CONTROL package

AGILITY CONTROL sports suspension

Dynamic Handling package

ADAPTIVE BRAKE

46 **Safe driving**

ATTENTION ASSIST

Intelligent Light System

DISTRONIC PLUS

LED tail lights

Adaptive brake lights

48 **In the event of danger or an accident**

PRE-SAFE® system

PRE-SAFE® Brake

Airbags

Active Bonnet

NECK-PRO head restraints

50 **Multimedia systems**

Central colour display

Controller

COMAND APS

Surround sound system

51 **Assistance systems**

PARKTRONIC including Parking Guidance

Reversing camera

Speed Limit Assist

52 **Climate control**

THERMATIC

THERMOTRONIC

54 **Seats**

Seats

Climatised seats

Multicontour seats

Automatic belt feeder

EASY-ENTRY system

Rear seats

E-Class Coupé in detail

56 Equipment

Standard

ELEGANCE interior concept
including upholstery and trim parts
AVANTGARDE interior concept
including upholstery and trim parts

62 Equipment packages

AMG Sports package

66 designo**68 Paintwork****70 Standard****72 Optional extras****74 Wheels**

Standard wheels

Optional wheels

AMG wheels

Wheels available as accessories

76 Genuine accessories**78 Technical data****80 Dimensions****81 Services**

Experience Mercedes-Benz at first hand

Mercedes-Benz Museum

MercedesCard

Mercedes-Benz mobility

Mercedes-Benz Bank

Test drive

Interactive Owner's Manual

Mobile marketing

TrueBlueSolutions

Climate change is one of the major challenges of the 21st century. The rising consumption of natural resources is having an increasing impact on our planet. As the inventor of the motor car, Mercedes-Benz has a special responsibility to implement innovative technologies in order to develop solutions that help preserve the environment and ensure that raw materials are used as efficiently as possible – without compromising on comfort, safety and driving enjoyment. We call them TrueBlueSolutions.

Our goal is emission-free mobility. To come closer to achieving this goal, we have developed a number of concepts, one of which is **BlueEFFICIENCY**. This custom-designed package of efficiency measures can reduce fuel consumption by up to 23 %: various aerodynamic and energy-management measures are implemented individually for each model to maximise savings in each case. These include tyres with low rolling resistance, lightweight materials,

aerodynamic body design and the automatic ECO start/stop function. As for diesel engines, Mercedes-Benz has brought to market its **BlueTEC** technology based on common-rail direct injection (CDI). This technology is the embodiment of the world's cleanest diesel as it can reduce nitrogen oxides by up to 80 %. Great things are also expected of **BlueHYBRID** technology - a combination of a highly efficient internal combustion engine and an electric motor. Vehicles equipped with this drive system raise the bar once again in terms of economy and cleanliness, as shown by the S-Class from 2009 onwards. Mercedes-Benz calls the equivalent technology for diesel vehicles **BlueTEC HYBRID**. A prototype version of this system can be seen in the Vision GLK 300 BlueTEC HYBRID1, which is currently the world's cleanest and most economical SUV. It returns a combined consumption figure of just 5.9 l/100 km. And with the F700 research vehicle, we have succeeded in combining the advantages of a petrol engine

with those of a diesel powerplant. The **DIESOTTO** drive at the heart of the F700 may have petrol in the tank; however, it operates like an economical diesel model in many driving situations. Mercedes-Benz also sees great potential in the development of the fuel cell. This highly promising drive system requires no mineral fuel whatsoever and operates with zero emissions. The first of these vehicles to be built under series-production conditions – the B-Class **F-CELL** – is due to be manufactured from 2010.



BlueEFFICIENCY. Numerous models, various measures, one goal: maximum efficiency

However, our extensive TrueBlueSolutions concept does not just include new drive technologies. Under the banner **Design for Environment**, we look at the vehicle's entire lifecycle – from planning to recycling. The same applies to the building and running of new plants. We save energy, avoid pollutants and we are increasing the use of renewable raw materials. Incidentally, Mercedes-Benz is the world's only car brand to have received the independently awarded German Technical Inspection Authority² environmental certificate. TrueBlueSolutions also



BlueHYBRD. In the S-Class from 2009. Look forward to one of the world's most economical luxury saloons

involves the active participation of the Group and its employees in environmental protection measures both inside and outside the company's plants. And it incorporates a commitment to developing second-generation alternative fuels (BTL/Biomass-to-Liquid fuels), such as SunDiesel[®], which are not at odds with food production. Another aspect of TrueBlueSolutions is the research discipline of bionics, which looks at structures and designs in the natural world in order to optimise the weight and aerodynamics of body constructions, for example. Last but not least,



BlueTEC HYBRID. The Vision GLK 300 BlueTEC HYBRID¹ is the most efficient combination of BlueTEC diesel and hybrid modules

you can also do your bit for TrueBlueSolutions by adapting your driving style.

For further information on our extensive package of measures, go to www.mercedes-benz.com/truebluesolutions

¹ Provisional figures: combined fuel consumption: 5,9 l/100 km; overall CO₂ emissions: 157 g/km

The figures are not based on an individual vehicle and do not constitute part of the product offer; they are provided solely for purposes of comparison between different vehicle models

² Southern German Technical Inspection Authority Management Service GmbH, Munich



F-CELL. Emission-free mobility with the drive system of the future: the B-Class F-CELL goes into production in 2010

Diesel engines

The new E-Class Coupé has the latest generation of Mercedes-Benz diesel engines at its disposal. They are fitted with particulate filters, meet the stringent EU 5 emissions standard and are even more economical, powerful, clean and quiet than the predecessor models.



The new 4-cylinder diesel engine in the E 250 CDI BlueEFFICIENCY combines pulling power with low consumption

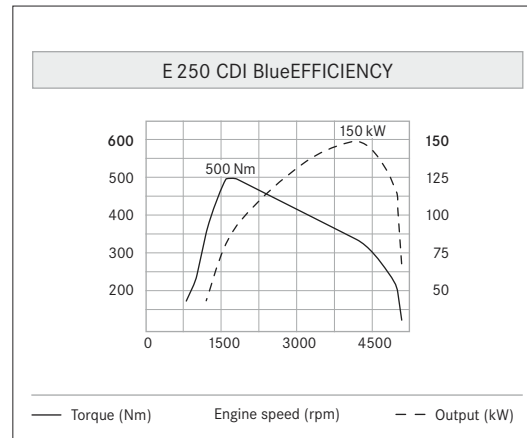

The new E 250 CDI BlueEFFICIENCY combines economy and performance

The 4-cylinder diesel engine. Beavering away in the E 250 CDI BlueEFFICIENCY is a completely newly developed 4-cylinder diesel engine. Particularly impressive are its pulling power, refinement and economy. Its maximum torque of 500 Nm is already available in the lower engine speed range between 1600 and 1800 rpm – and can call up 150 kW (204 hp) if required.

The engine is now up to 20% more powerful than previous comparable models, whilst torque has increased by up to 25%. At the same time fuel consumption and CO₂ emissions have dropped by up to 13%. Co-responsible for these impressive

achievements are fourth-generation common-rail technology, whose injection pressure has been increased to 2000 bar, as well as optimised combustion chambers and extremely precise piezo injectors. Meanwhile two-stage charging ensures high torque in every engine speed range, whilst the requisite refinement comes courtesy of two Lanchester balancer shafts.

The 6-cylinder engine. Impressive figures characterise the E 350 CDI BlueEFFICIENCY. With its six cylinders the engine produces an output of 170 kW (231 hp) and a maximum torque of 540 Nm at 1600–2400 rpm: a healthy reserve for spontaneous sprints. At the same time the engine works cleanly and economically, with help from the quick and precise piezo injectors and the injection pressure of up to 1600 bar plus the lightweight design throughout.

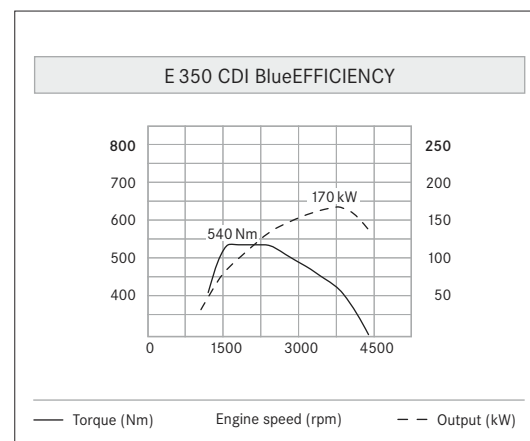

The new E 350 CDI BlueEFFICIENCY posts an excellent set of output and torque figures

Petrol engines

Fun at the wheel and environmental compatibility can go hand in hand: thanks to newly developed engine technologies from Mercedes-Benz that are impressively powerful but at the same time reduce CO₂, as proven by the petrol models.



The latest engine technology featuring high-pressure direct injection with piezo injectors in the E 250 CGI BlueEFFICIENCY

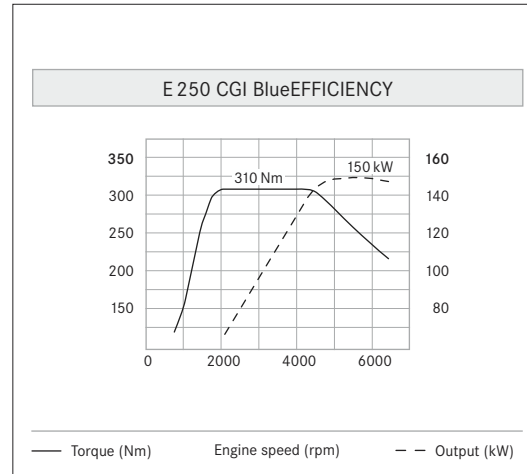

Highly efficient and conserves resources: the newly developed E 250 4-cylinder petrol engine

The new 4-cylinder petrol engine with direct injection. There is a particularly efficient unit at work in the E 250 CGI BlueEFFICIENCY: the 4-cylinder in-line engine with turbocharging and direct injection. Not only does its design ensure refinement in all engine speed ranges; it also facilitates the high output of 150 kW (204 hp) and the impressive torque of 310 Nm without much displacement – just 1.8 l to be precise. The resultant reduced weight and the lower internal friction keep consumption well and truly down. What's more, the CGI direct injection makes a worthy contribution to the engine's efficiency as it needs less petrol.

The 6-cylinder petrol engine. State-of-the-art technology forms the basis for the drive system in the E 350 CGI BlueEFFICIENCY: 4 valves per cylinder, variable intake and exhaust camshaft adjustment, a two-stage intake manifold and a balancer shaft. The E 350 CGI BlueEFFICIENCY saves fuel, reduces CO₂ emissions and impresses with enhanced refinement. These advantages are down to the second-generation direct petrol injection system from Mercedes-Benz, which operates using spray-guided combustion and high-pressure injection. Maximum power and peak torque – 215 kW (292 hp) and 365 Nm respectively – are available in a wide range from 3000 to 5100 rpm.

The 8-cylinder petrol engine. The crowning glory in the range of engines for the new E-Class Coupé is a superb specimen: the E 500. This 8-cylinder unit boasting 285 kW (388 hp) develops a maximum torque of 530 Nm at 2800 to 4800 rpm. Accelerating from 0 to 100 km/h in 5.4 seconds and with a top speed of 250 km/h, the E 500 is a sports car through and through.

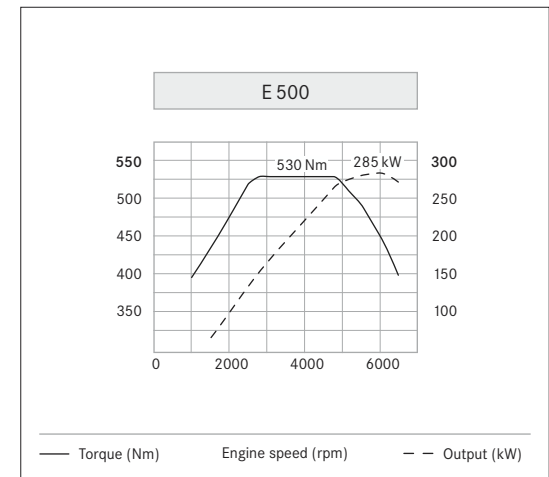

The E 500 places its impressive torque of 530 Nm at your disposal from 2800 rpm

Exhaust systems

With their chic chrome look the exhaust systems emphasise the new E-Class Coupé's sporty ambitions. They are precisely tailored to each engine to ensure optimum performance figures.

There are three different exhaust systems available for the E-Class Coupé: the 4-cylinder models are fitted with an oval tailpipe, the 6-cylinder models with two oval tailpipes. The 8-cylinder

engine in the E 500 also has a two-pipe exhaust system; as a differentiating feature the trapezoidal pipe is integrated into the bumper covering. A catalytic converter for the petrol models

and a particulate filter for the diesel models are obligatory.



The 4-cylinder models have an oval tailpipe



The 6-cylinder models are fitted with two oval tailpipes



The two-pipe exhaust system with its trapezoidal tailpipes distinguishes the 8-cylinder model

Transmissions

Whether you prefer a dynamic or a more relaxed driving style, the manual and automatic transmissions for the new E-Class Coupé ensure optimum engine power transmission in each and every traffic situation.

The transmissions for 4-cylinder models: the 6-gear manual transmission in the E 250 CDI BlueEFFICIENCY facilitates particularly fast gear changes with very short and precise shift

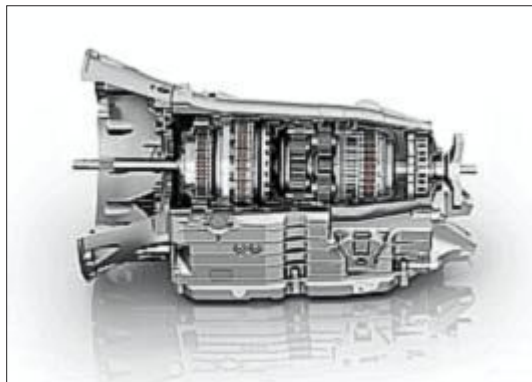

Individual gears can be skipped when changing down with the 7G-TRONIC if spontaneous acceleration is called for

travel. At the same time ride comfort is increased through precise tuning of the engine output, gear spacing and rear axle ratio. The 5-speed automatic transmission in the E 250 CGI BlueEFFICIENCY (optional for the E 250 CDI BlueEFFICIENCY) works with five gears and is electronically governed. The automatic transmission also lets you change gear manually by pressing the selector lever towards the left or right. At the touch of a button you can select two shift programs with which the transmission characteristics and shift points are determined: “C” mode for an economical driving style and “S” mode for a sporty driving style.

The transmission for 6 and 8-cylinder models: the seven forward gears on the 7G-TRONIC transmission ensure that you always drive in the optimum engine speed range, which means that fuel consumption can be reduced. When overtaking or in situations requiring spontaneous pulling power, individual gears can be skipped. The shift programs “C” and “S” are also selectable at the touch of a button for the 7G-TRONIC.

Chassis and suspension

The new E-Class Coupé is tuned to both comfortable and sporty driving styles. The Dynamic Handling package increases fun at the wheel even further with its selectable suspension and transmission setups.

AGILITY CONTROL package (standard). With its selective damping system the suspension is constantly and variably adjusted to suit the road conditions and your driving style. In the case of weaker shocks it reduces the damping force individually for each wheel and increases road roar and tyre vibration characteristics. When the vehicle encounters more pronounced uneven sections the system steps up the damping effect and can increase driving stability. In addition to this the steering has a more direct ratio and, in conjunction with the manual transmission, short shift travel means even more precise wheel control.

AGILITY CONTROL sports suspension with speed-sensitive power steering (optional/standard in conjunction with AMG Sports package). In comparison with the standard-fit AGILITY

CONTROL suspension the springs and shock absorbers of the AGILITY CONTROL sports suspension are more tightly tuned. This leads – especially when the driving style is dynamic – to reduced rolling motions and improves the handling of the E-Class Coupé. The more direct steering ratio of the speed-sensitive sports steering supplements the suspension by enabling a more spontaneous transfer of the steering movements to the road.

Dynamic Handling package (optional/standard on the E 500). With the Dynamic Handling package just a simple touch of the “SPORT” button is all it takes to switch all the related systems from the regular comfort mode to the sports mode. The damping becomes noticeably tighter and the engine’s response to the accelerator pedal is

much more direct. At the same time the shift program of the automatic transmission changes to a more forthright mode which ensures optimum acceleration at all times. The speed-sensitive sports steering creates a sporty and direct steering sensation in both driving modes.

ADAPTIVE BRAKE (standard). The ADAPTIVE BRAKE system lends the new E-Class Coupé more ride comfort and safety. Together with the anti-lock braking system ABS it helps drivers to master critical braking manoeuvres. With its functions for dry braking in wet conditions and priming the brakes respond more directly. When starting off on an incline unintentional rolling back is prevented and (if you press the brake pedal a second time) the HOLD function keeps your vehicle securely in its place in any situation.



The Dynamic Handling package with its sports mode: decidedly sporty driving at the touch of a button for more agile driving characteristics, optimum vehicle control and improved handling at higher speeds

Safe driving

Mercedes-Benz pursues a comprehensive safety philosophy: the integral safety concept. At its core lies the vision of accident-free driving: numerous measures support the driver in critical situations and can help to prevent an accident.

ATTENTION ASSIST (standard). This new drowsiness detection system is especially useful on long trips. At speeds of between 80 and 180 km/h, ATTENTION ASSIST warns the driver as soon as it detects signs of drowsiness or inattention. All thanks to sensors that analyse driving behaviour and detect any changes compared with the driver profile individually determined previously.



If the driver shows signs of drowsiness, ATTENTION ASSIST recommends taking a break

Intelligent Light System (optional). With its four automatic settings this system ensures the best possible visibility in every driving situation. In the rural-road mode the edge of the road is illuminated much better than is the case with conventional headlamps. The motorway mode provides the same degree of illumination for the entire width of the carriageway. With the extended fog lamp function the left-hand bi-xenon headlamp swings outwards and improves

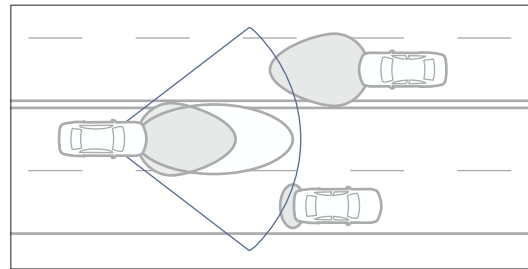

Adaptive Highbeam Assist ensures a virtually seamless transition between low and main beam

visibility. The active cornering light function follows the driver's steering angle. And in addition to all this Highbeam Assist gives the driver an even better overview: the vehicle's own light is only dimmed to such an extent that drivers of oncoming vehicles or of vehicles in front are not dazzled.

DISTRONIC PLUS (optional). The DISTRONIC PLUS proximity control uses short-range and

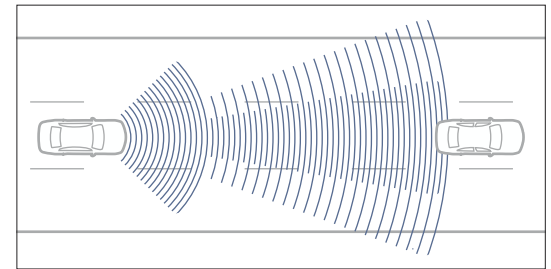

The DISTRONIC PLUS proximity control automatically keeps the coupé at a safe distance from the vehicle in front

long-range sensors to maintain the desired safe distance to the vehicle in front. The system operates at speeds of between 0 and 200 km/h and is also helpful in city traffic or stop-and-go traffic as the sensors can operate in a range of between 0.2 and 200 metres.

LED tail lights and adaptive brake lights (standard). Both the tail lights and brake lights plus the third brake light employ LEDs. They are significantly faster in comparison with conventional bulbs and they emphasise the sporty design of the tail end. During emergency braking the adaptive brake lights warn following traffic of the danger by blinking.



The particularly fast LED tail lights and the adaptive brake lights are an important boost for perceptive safety

In the event of danger or an accident

The new E-Class Coupé is fitted with a system that is capable of recognising driving situations where there is the danger of an accident. The consequences of an accident can thus be lessened and the passengers afforded as much protection as possible.

PRE-SAFE® system (standard). The PRE-SAFE® preventive occupant protection system can recognise critical driving situations in advance and then initiate preventive measures in order to protect the occupants: the side windows and the panoramic glass roof can be closed, the front passenger seat moved into a more favourable position and the seat belts electromotorically tensioned.

PRE-SAFE® Brake (optional in conjunction with DISTRONIC PLUS). If a vehicle in front brakes abruptly or if the coupé gets dangerously close, the PRE-SAFE® Brake can initiate a partial brake application. In so doing the system works together with the DISTRONIC PLUS radar sensors which can recognise the imminent danger of a collision. The BAS PLUS also supports the driver when braking - in a manner appropriate to the situation in hand.

Airbags (standard/optional). Integrated into all the seats in the E-Class Coupé are front airbags with two-stage deployment, front sidebags and windowbags. There is also the kneebag for the driver, in order to protect the legs - and in particular the knees - against injury in case of an accident. Rear sidebags are available as an option.

Active Bonnet (standard). The Active Bonnet can reduce the risk of injury to pedestrians or cyclists if they are involved in a collision with the bonnet. To cushion the blow, the bonnet can raise approximately five centimetres at the rear by means of spring force.

NECK-PRO head restraints (standard). The NECK-PRO head restraints for the driver and front passenger can be activated in a rear impact: a spring mechanism moves forwards and upwards, the head is thus supported earlier and the strain on the spine reduced.

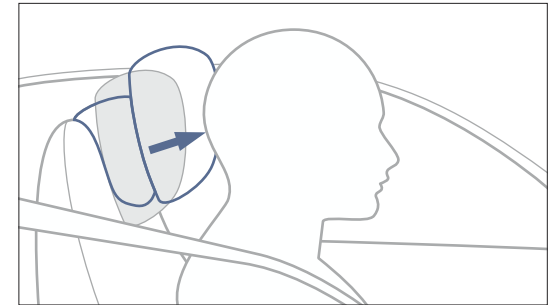

The NECK-PRO head restraints can reduce the risk of whiplash in a rear impact



Multimedia systems

The highest levels of comfort take centre stage in the new E-Class Coupé. Whilst the COMAND APS multimedia system entertains and navigates, all the elements can be easily reached via the controller, the multifunction steering wheel and the optional voice-operated control system LINGUATRONIC.

Central colour display and controller (standard). Situated in front of the centre armrest, the controller, operated intuitively, is used in combination with the central display for controlling the audio and multimedia functions. It adds to the numerous operating possibilities offered by the multifunction steering wheel.



Ergonomically optimum: the controller is housed in front of the centre armrest

COMAND APS (optional). The COMAND APS multimedia system combines navigation, audio and telephone functions and shows all the information you need in its 7-inch colour display. The integrated DVD drive plays CDs and MP3 files as well as video and audio DVDs. It can be operated by giving voice commands if the voice-operated control system LINGUATRONIC is ordered.



All the information you need at a glance: COMAND APS clearly shows the navigation, entertainment and telephone functions

Harman Kardon® Logic 7® surround-sound system (optional). With no less than twelve loudspeakers, including a subwoofer, this 450-Watt Dolby Digital 5.1 system provides a first-class musical experience. The speed-dependent volume regulation enhances your pleasure even further by ensuring a constant sound impression.

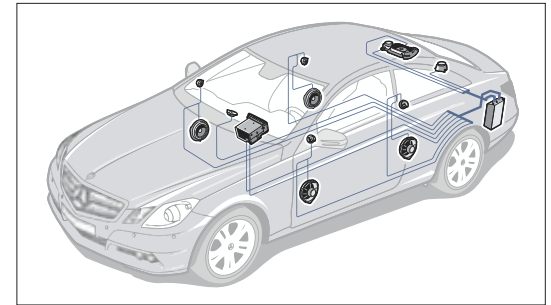

The Harman Kardon® Logic 7® surround-sound system automatically regulates the volume in accordance with the vehicle's speed

Assistance systems

There are numerous assistance systems to provide relaxation on the road. Their job is to support the driver when driving, but also when performing sensitive manoeuvres.

PARKTRONIC including Parking Guidance (optional). Parking Guidance comes to the driver's aid when parking and finding a parking space. The system uses measured data from ultrasound sensors to determine whether the length of a space is adequate, and helps by providing instructions on the correct steering angle and the points at which to turn or reverse.



Parking Guidance indicates suitable parking spaces to the driver and provides parking directions

Reversing camera (optional). A reversing camera with a wide-angle rearview mirror shows what is behind the vehicle – which is particularly helpful when parking and reversing. The picture appears on the central display in the cockpit.



The reversing camera shows the area behind the tail end of the vehicle which is difficult to see

Speed Limit Assist¹ (optional). The system boosts safety by recognising traffic signs and showing the speed limit given on them in the cockpit. Variable speed limit displays and speed limits put in place at short notice, such as in the case of road works, are also recognised.



Speed Limit Assist even warns you about temporary speed limits

¹ Available from approx. 4th quarter of 2009

Climate control

An interior climate that can be individually optimised enhances driving pleasure even further and increases driver-fitness safety. In the new E-Class Coupé the temperature can be individually set for two or three zones.

THERMATIC (standard). The 2-zone automatic climate control THERMATIC automatically keeps the temperature constantly at the desired level for the driver and front passenger. Sensors record the interior and exterior temperatures and other data such as the intensity and direction of sun-

light, and for each of the two temperature zones individually adjust the heating, cooling or fan as necessary. The system also includes air recirculation, a defrost outlet for the windscreen and a fine particle filter.

THERMOTRONIC (optional/standard for the E 500). The 3-zone luxury automatic climate control THERMOTRONIC has separate temperature controls for various parts of the interior, allowing the driver, front passenger and rear passengers to travel in comfort at the temperature of their choice. At the touch of a button the 3-zone system works fully automatically – in addition to individual temperatures the climate styles DIFFUSE, MEDIUM and FOCUS are available for selection. THERMOTRONIC keeps the desired temperature constant and also takes exterior factors such as sunlight, air quality and humidity into account via its sensors.



The luxury automatic climate control THERMOTRONIC can be operated both in the cockpit and via a control unit in the rear



The automatic climate control THERMATIC allows individual temperatures to be set in two vehicle zones

Seats

The newly developed seats combine seating comfort with ergonomics, safety and sportiness – both in the front and in the rear. Systems such as the automatic belt feeder and the rear entry aid add yet more comfort.



The front seats are ergonomically adjustable to ensure a relaxing journey

The front seats with standard-fit NECK-PRO head restraints are ergonomically shaped and give the driver and front passenger optimum support, even when the driving style is particularly dynamic. Their height and backrest angle can be electrically adjusted.

With the optional climatized seats the front seats are actively ventilated and heated. The multi-contour seats (optional), which also offer ventilation and heating, feature integrated inflatable air chambers. A lumbar support with two air chambers in the back area and in the seat side bolsters of the backrest plus a chamber for extending the seat cushion length ensure perfect adjustment of the seat to your sporty and orthopaedic needs.

Automatic belt feeder (standard). To help with fastening the seat belt the automatic belt feeder brings the seat belt into an easily accessible position. The belt feeder can also be activated via a button on the centre console.

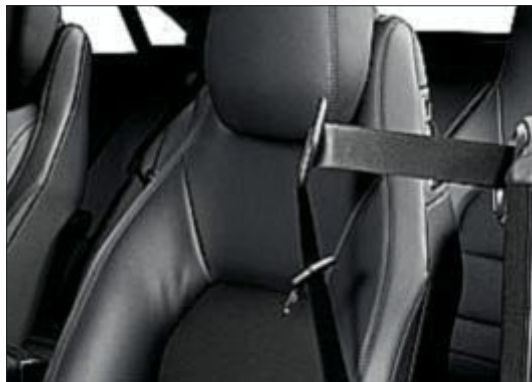

The automatic belt feeder extends the seat belt

EASY-ENTRY system (standard). If rear passengers wish to get in or out of the car, the entire front seat is moved forwards. In conjunction with the optional Memory package (standard-fit for the E 500) the seats move into the EASY-ENTRY position and back again electrically.



The front seats fold forwards, allowing the rear passengers to get in and out of the vehicle easily

Rear seats (standard). The rear passengers take a seat on upholstery in an individual seat look with integrated head restraints. The area between the seats has a stowage compartment and double cup holder. The backrest can be folded so that bulky items can be transported with ease.



Passengers in the rear take a seat on comfortable upholstery



Standard equipment

The new E-Class Coupé is poised to make a grand entrance, for example with its daytime driving lights featuring LED tail lights. You can choose between the ELEGANCE and AVANTGARDE interior concepts to embellish the interior with trim parts in brushed aluminium.

EXTERIOR

19-inch multi-spoke light-alloy wheels

Chrome trim, for example on the front and rear bumper

Front fog lamps and daytime driving lights
in a twin circular design in the bumper

Rear diffuser in the vehicle colour

INTERIOR

3-spoke sports steering wheel and shift/selecter lever
in nappa leather

Door sill panel with Mercedes-Benz lettering and exit lighting
(see illustration, bottom right)

Fabric/ARTICO man-made leather upholstery

Front seats with electrically adjustable height and backrest angle

Individual seats with integral head restraints and automatic belt
feeders in the front





The ELEGANCE interior concept with a black backplate in the instrument cluster

ELEGANCE

The ELEGANCE interior concept emphasises the E-Class Coupé's classic feel, with its tone-in-tone atmosphere, soft contrasts between the dashboard, steering wheel and shift/selector lever and the light A and C pillars and roof liner.

BLACK

711 Fabric/ARTICO man-made leather¹

201 Leather²

801 Nappa leather²

ALPACA GREY

718 Fabric/ARTICO man-made leather¹

208 Leather²

808 Nappa leather²

ALMOND BEIGE

205 Leather²

805 Nappa leather²

TRIM PARTS

739 Brushed aluminium

731 Burr walnut²

H13 Brown pine²

¹ Not in conjunction with AMG Sports package

² Optional extra



711



718

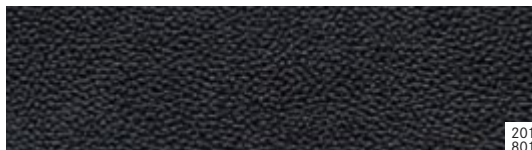

201
801



208
808



205
805



739



739



739



731



731



731



H13



H13



H13



The AVANTGARDE interior concept with its silver-coloured backplate in the instrument cluster

AVANTGARDE

The AVANTGARDE interior concept emphasises the E-Class Coupé's sporty side and has a black theme featuring black A and C pillars and a black roof liner.

BLACK/BLACK

701 Fabric/ARTICO man-made leather¹

101 ARTICO man-made leather²

251 Leather³

851 Nappa leather³

BLACK/ALPACA GREY

258 Leather³

858 Nappa leather³

BLACK/ALMOND BEIGE

255 Leather³

855 Nappa leather³

BLACK/NATURAL BEIGE

254 Leather³

BLACK/FLAMENCO RED

257 Leather³

TRIM PARTS

739 Brushed aluminium

736 Black ash³

¹ Not in conjunction with AMG Sports package

² Standard with AMG Sports package

³ Optional extra

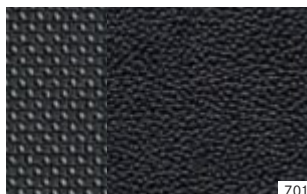

701

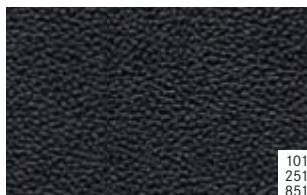

101
251
851



258
858

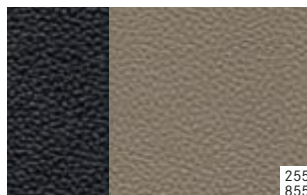

255
855

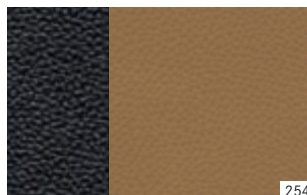

254

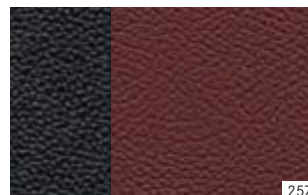

257



739



739



739



739



739



736



736



736



736



736



AMG Sports package

The new E-Class Coupé's sporty appearance is rounded off perfectly by the AMG Sports package which is available as an optional extra. For the exterior, for example, there is a dynamic AMG front and rear apron, the powerful side sill panels, high-shine 18-inch AMG 6-twin-spoke light-alloy wheels and large, perforated brake discs at the front with Mercedes-Benz lettering.



EXTERIOR

18-inch AMG 6-twin-spoke light-alloy wheels, high-shine finish

AGILITY CONTROL sports suspension

AMG bodystyling, comprising: front apron, side sill panels and rear apron

Large, perforated brake discs at the front and brake callipers with Mercedes-Benz lettering

Speed-sensitive sports steering with a more direct ratio



AMG Sports package

The dynamic ambitions of the optional AMG Sports package are also very much in evidence in the interior: in the form of multicontour seats at the front in ARTICO man-made leather, for example, and the AMG sports steering wheel in nappa leather, floor mats with AMG lettering and sports pedals. What's more, all the nappa leather upholsteries from the ELEGANCE and AVANTGARDE interior concepts plus the individual trim parts can be selected as an option.

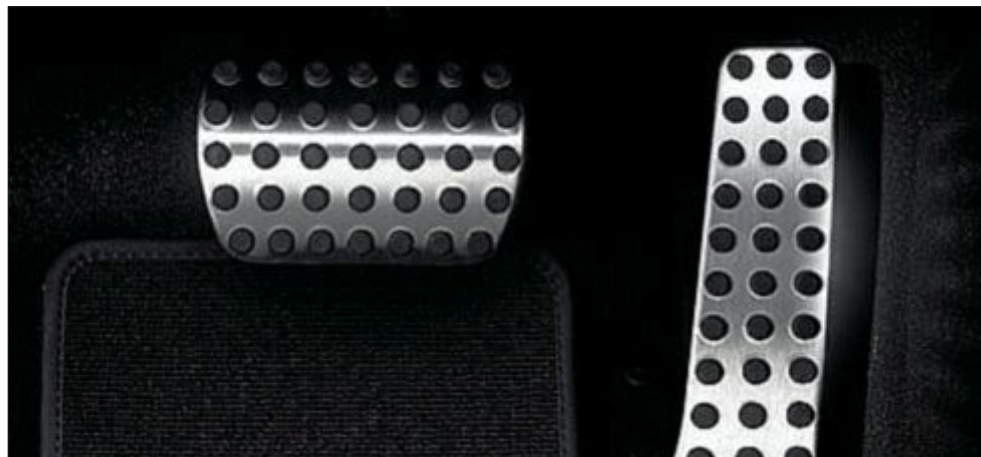

INTERIOR

AMG sports steering wheel in nappa leather

ARTICO man-made leather upholstery, black; leather and nappa leather and wood trim parts available as an option

Brushed stainless steel sports pedals with rubber studs

Floor mats with AMG lettering

Multicontour seats for driver and front passenger

Steering-wheel gearshift paddles in conjunction with automatic transmission



designo

designo meets your extra-special requirements: with its exclusive leather appointments and trim parts. The Mercedes-Benz individualisation range provides an incomparable personal touch.

designo gives you the opportunity to inject maximum individuality into the new E-Class Coupé. The carefully selected materials are handcrafted with meticulous precision, creating an unmistakable masterpiece. The two-tone designo seats with an individual upholstery layout and the door linings are covered in exclusive designo porcelain leather. Trim parts covered in leather add even more elegance.



Leather selector lever trim, porcelain leather trim parts (Code W80)



Seat in designo porcelain leather with a metal badge (Code X87)

Paintwork

The innovative paint system from Mercedes-Benz comprises one of the very best clear coats available on the automotive market and makes a decisive contribution towards the vehicle's value retention. Its secret lies in the extremely dense molecular structure.

NON-METALLIC PAINTS

- 040 black
- 590 fire opal
- 650 calcite white

METALLIC PAINTS¹

- 197 obsidian black
- 230 indigolite blue
- 359 tanzanite blue
- 755 tenorite grey
- 775 iridium silver
- 792 palladium silver
- 798 sanidine beige
- 799 diamond white BRIGHT

SPECIAL PAINT¹

- 786 stannite grey
-

NON-METALLIC PAINTS



METALLIC PAINTS



¹ Optional extra

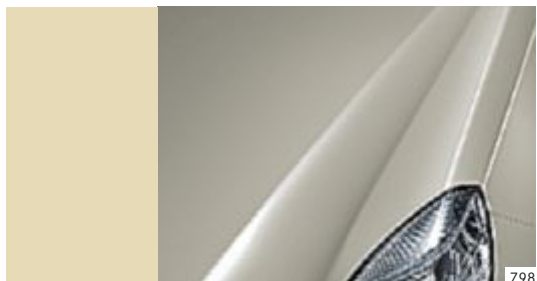

SPECIAL PAINT

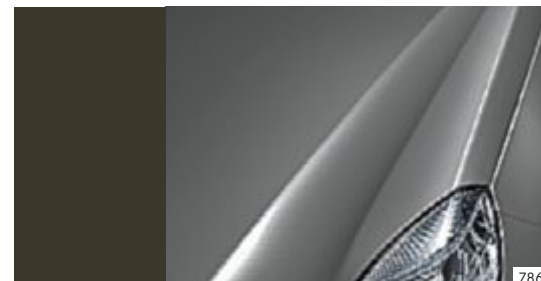

Standard | Selection



12-button multifunction steering wheel in nappa leather



THERMATIC automatic climate control



AUDIO 20 CD



Power windows (4)



Shift/selector lever in nappa leather



NECK-PRO head restraints



Cruise control including SPEEDTRONIC



Button on centre console for belt feeder



Tyre pressure loss warning system



Proj.-beam headlamps, front fog lamps & daytime driving lights



Rain sensor and light sensor for Headlamp Assist



Boot with lighting

Optional extras | Selection



Audio 50 APS



COMAND APS multimedia system



TV tuner



Memory package



Adaptive Highbeam Assist



Harman Kardon® Logic 7® surround sound system



Voice-operated control system LINGUATRONIC



Climatised seats with button for seat ventilation/seat heating



DISTRONIC PLUS proximity control



Intelligent Light System with LED daytime driving lights



Panoramic glass roof



Rear roller blind, electric

Wheels



16-inch 9-spoke fuel-economy wheel (no extra charge for 4-cylinder or for 350 CGI BlueEFFICIENCY, Code R12)



17-inch 5-twin-spoke light-alloy wheel (no extra charge for 4 and 6-cylinder, Code R11)



17-inch multi-spoke light-alloy wheel (standard for 4 and 6-cylinder)



17-inch 5-twin-spoke light-alloy wheel with mixed-size tyres (optional for 4 and 6-cylinder, Code R52)



18-inch 5-spoke light-alloy wheel with mixed-size tyres (optional, Code R32, standard for 8-cylinder)



incenio "Lugo" 16-inch 10-spoke designer wheel (accessory)



incenio "Shikrio" 18-inch 5-twin-spoke designer wheel with mixed-size tyres (accessory)



18-inch 6-twin-spoke AMG light-alloy wheel with mixed-size tyres (optional, Code 786, standard with the AMG Sports package)



incenio "Khotrima" 17-inch 5-twin-spoke light-alloy wheel with mixed-size tyres (accessory)



Alustyle basic carrier bars with XL roof box in calcite white

Genuine accessories

The Mercedes-Benz Genuine accessories range offers everything you need to make the new E-Class Coupé even more practical: a whole host of accessory products perfectly tailored to the vehicle.

The Alustyle basic carrier bars help you keep your options open when transporting sports equipment and items of luggage. You can combine the basic carrier bars with a large variety of different roof equipment, such as the Mercedes-Benz roof boxes, which are available in 330, 400 and 450-litre versions. The “Comfort” ski and snowboard rack enables you to transport 6 pairs

of skis or 4 snowboards. There is also an array of products for the boot, including the shallow boot tub, made from food-safe material. And for iPod® and iPhone® users there is the iPod® Interface Kit, which can be used to integrate the MP3 player into your vehicle's audio system. It is operated via the multifunction steering wheel and the playlist is shown in the instrument cluster.

Further information on the range of Mercedes-Benz Genuine accessories is available in our special brochure or from your Mercedes-Benz dealer



Alustyle basic carrier bars with ski and snowboard rack



Mercedes-Benz iPod® Interface Kit



Boot tub, shallow

Technical data

	DIESEL ENGINES	
	E 250 CDI BlueEFFICIENCY ¹	E 350 CDI BlueEFFICIENCY
No. of cylinders/arrangement	4/in-line	6/V
Total displacement (cc)	2143	2987
Rated output ³ (kW at rpm)	150/4200	170/3800
Rated torque ³ (Nm at rpm) (manual transmission)	500/1600–1800 (500/1600–1800)	540/1600–2400
Compression ratio	16.2	15.5
Acceleration 0–100 km/h (s) (manual transmission)	7.2 (8.1)	6.1
Top speed, approx. (km/h) (manual transmission)	249 (250 ⁴)	250 ⁴
Tyre size, front	235/45 R 17	235/45 R 17
Tyre size, rear	235/45 R 17	235/45 R 17
Fuel	Diesel	Diesel
Fuel consumption ⁵ l/100 km		
urban (manual transmission)	n/a (n/a)	8.9
extra-urban (manual transmission)	n/a (n/a)	5.6
combined (manual transmission)	5.8 (5.3)	6.8
CO ₂ emissions ⁵ (g/km), combined (manual transmission)	158 (138)	179
Tank capacity (l)/incl. reserve, approx.	66/8	66/8
Boot capacity (l)	450	450
Turning circle diameter (m)	10.95	10.95
Kerb weight ⁶ (kg) (manual transmission)	1690 (1695)	1730
Perm. GVW (kg) (manual transmission)	2165 (2165)	2180

¹ Available from 06.2009. Some of the figures shown are provisional

² Available from 09.2009. Some of the figures shown are provisional

³ Figures according to Directive 80/1269/EEC in the currently applicable version

⁴ Electronically governed

⁵ The figures shown were obtained in accordance with the prescribed measuring process (Directive 80/1268/EEC in the currently applicable version). The figures are not based on an individual model and do not constitute part of the

	PETROL ENGINES		
	E 250 CGI BlueEFFICIENCY ²	E 350 CGI BlueEFFICIENCY	E 500
No. of cylinders/arrangement	4/in-line	6/V	8/V
Total displacement (cc)	1796	3498	5461
Rated output ³ (kW at rpm)	150/5500	215/6400	285/6000
Rated torque ³ (Nm at rpm)	310/2000-4300	365/3000-5100	530/2800-4800
Compression ratio	9.3	12.2	10.7
Acceleration from 0-100 km/h (s)	7.6	6.3	5.4
Top speed, approx. (km/h)	248	250 ⁴	250 ⁴
Tyre size, front	235/45 R 17	235/45 R 17	235/40 R 18
Tyre size, rear	235/45 R 17	235/45 R 17	255/35 R 18
Fuel	Premium petrol	Premium petrol	Premium petrol
Fuel consumption ⁵ (l/100 km)			
urban	n/a	12.3-12.4	16.1
extra-urban	n/a	6.3-6.6	7.8
combined	7.0	8.5-8.7	10.9
CO ₂ emissions ⁵ (g/km) combined	164	199-203	254
Tank capacity (l)/incl. reserve, approx.	66/8	66/8	66/8
Boot capacity (l)	450	450	450
Turning circle diameter (m)	10.95	10.95	10.95
Kerb weight ⁶ (kg)	1580	1670	1715
Permissible gross vehicle weight (kg)	2050	2140	2180

product offer; they are provided solely for purposes of comparison between different vehicle models. The figures shown are provisional

⁶ Figures according to Directive 92/21/EC, version 95/48/EC (kerb weight with fuel tank 90% full, driver, 68 kg and luggage, 7 kg) for standard-specification vehicles. Optional extras and accessories will generally increase this figure and reduce the payload capacity accordingly

Dimensions

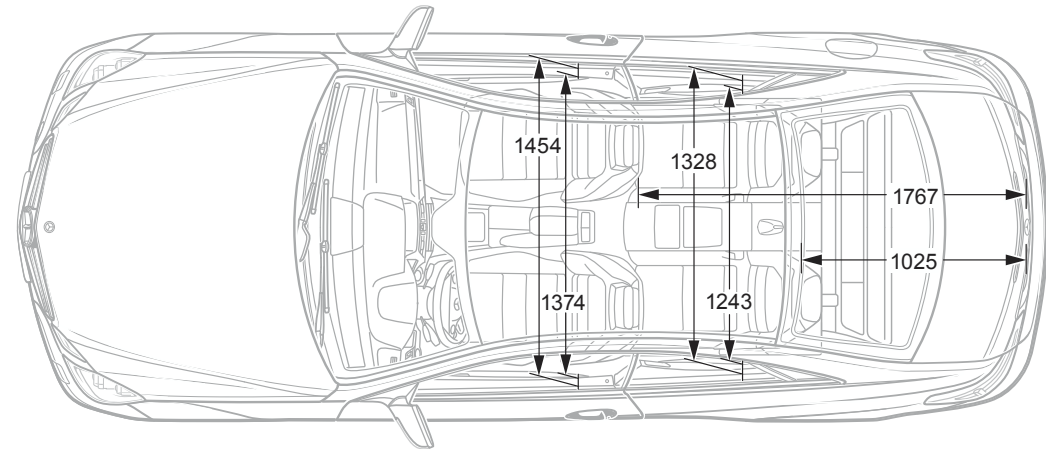
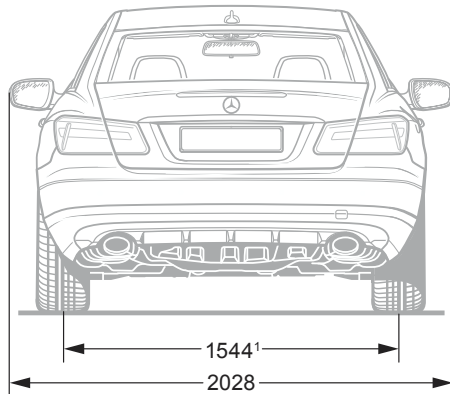
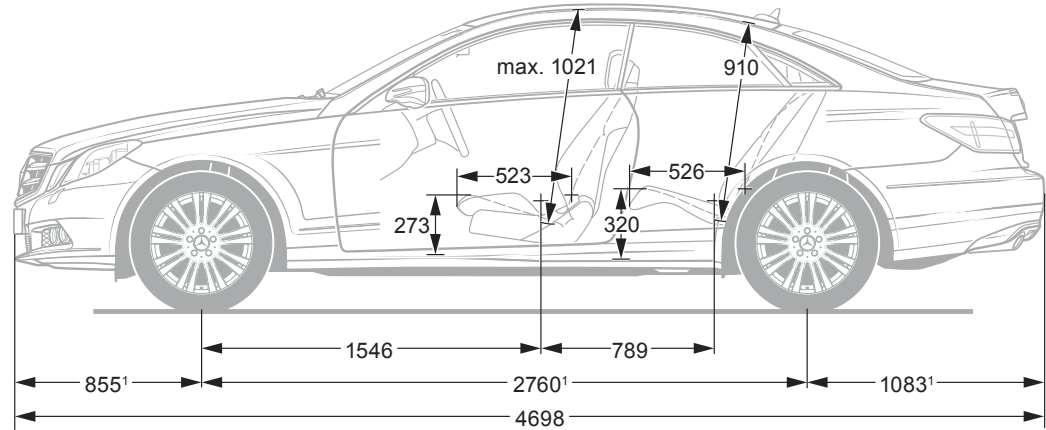
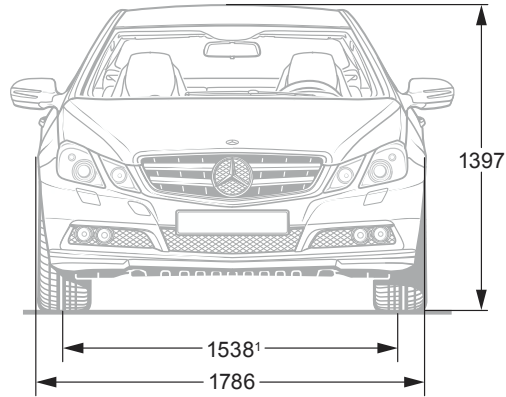

Services

Experience Mercedes-Benz at first hand. It all started in Berlin at the end of 2000: the concept of the car dealership was reinvented with the opening of the first Mercedes-Benz Center. Featuring the entire Mercedes-Benz model line-up as well as the accessories range, brand merchandise and an attractive programme of events, the Centers – now to be found in many of Europe's major cities – offer a welcoming environment in which to experience the brand up close and personal. But it's not just in large cities that you can experience the legendary Mercedes-Benz brand and service. A close-knit network of company-owned sales and service outlets and authorised dealers ensures that you are never far from the wide range of services, the comprehensive customer care and the high quality which you expect from Mercedes-Benz. And you can count on their support at every stage – before you buy your Mercedes, during the purchase process and, most importantly, for a long time afterwards too.

Mercedes-Benz Museum. More than 120 years of automotive history in one place – this is what awaits you at the Mercedes-Benz Museum in Stuttgart. Experience the unique excitement, and embark upon a thrilling journey through time. Housed inside an architecturally impressive building, over 1500 exhibits on nine levels give you an insight into the unique tradition and powers of innovation of the Mercedes-Benz brand. Plus you can see the world's first two cars in the shape of the Benz patent motor car and the Daimler motorised carriage – both from the year 1886. Two linked circuits take you from the beginnings of the car, past a series of unforgettable classics, through 100 years of motor-racing history and, finally, on to a glimpse of what the future holds – all in an area covering a total of 16,500 square metres. Enjoy the unique brand experience. We look forward to your visit.

MercedesCard. Your ticket to the Mercedes-Benz experience: the quarterly MercedesCard ARGENTUM journal offers you an exclusive selection of exciting events starring the Mercedes-Benz brand. In addition, the Mercedes Magazine is packed with gripping and inspiring articles and reports. The MercedesCard has many other functions: as a VISA credit card, it is an accepted form of payment worldwide – with no annual fee if you complete a questionnaire every year. In addition, it offers further benefits to put your mind at ease, such as the Mercedes-Benz insurance package, at no extra charge, and the exclusively compiled MercedesCard insurance package at a preferential rate. For further information about this offer, available exclusively to Mercedes-Benz drivers, visit www.mercedes-benz.de/mercedescard¹

¹ Information about the MercedesCard in Austria and Switzerland can be found on the Mercedes-Benz websites for these countries

Mercedes-Benz mobility. There will always be a helpful passenger in your new Mercedes-Benz: the assurance of carefree driving. If you should ever need assistance, the Mercedes-Benz Service24h is there for you round the clock, 365 days a year. Our specialists are there to assist you in your own language if you telephone the free-phone service hotline on 00800 1 777 7777¹. The newly integrated telematics service Mercedes-Benz Contact² is even more customer-friendly: it enables you to make contact with the Mercedes-Benz customer centre by telephone at the touch of a button. And if you wish, all the relevant vehicle and position-related data can be transmitted, so that your adviser has all the important information right from the start of the telephone conversation, thus ensuring the shortest possible reaction time, individual service and rapid on-the-spot help. As standard and at no extra charge: the Mercedes-Benz mobility package Mobilo – our 4-year warranty for your mobility³. Whether you have lost your key, are

having problems starting your car or have had a breakdown which cannot be repaired immediately – Mobilo ensures that you still reach your destination – anywhere in the whole of Europe, even if the vehicle is damaged as a result of an accident or vandalism. Should a repair take a little longer, we will even cover the cost of an overnight stay. But don't get too excited – after all, it's very rare for a Mercedes to break down. Whatever the nature of your problem, one thing is for certain: you will soon be able to resume your journey, satisfied that the problem has been solved.

¹ Mobile-phone rates may vary

² Freephone number, mobile-phone rates may vary

³ When the warranty has expired Mobilo can be extended by another year for a maximum of 30 years, provided that regular maintenance is carried out by your Mercedes-Benz service partner

Mercedes-Benz Bank. If you have already chosen your dream car and want to remain financially flexible, the Mercedes-Benz Bank should be your next port of call. We are your one-stop shop for leasing, financing, insurance and service packages. By way of example, our “Private Leasing plus” scheme is a complete package comprising leasing, liability and fully comprehensive insurance and a purchase option, while our “Plus3” finance package combines low rates with high flexibility. That's because, at the end of the contract, you decide yourself whether to keep your car, sell it or return it to us for a guaranteed price. We also offer an attractive range of investment products, including instant-access savings accounts, fixed-interest products and investment funds. For further information, please call us on 01803/32 22 65⁴ or visit us at: www.mercedes-benz-bank.de

⁴ 9 ct./min. from Deutsche Telekom landlines, mobile-phone rates may vary

Test drive. A Mercedes-Benz is most at home on the road. This is the only way to experience the effortlessly superior driving feel that lends every model its inimitable class. Feel the power of the engine as it propels the car forwards. Marvel at the precise steering, designed to really put you in the mood for driving. And experience what true comfort really feels like. The unique feeling of driving a Mercedes cannot be put into words, however. Which is why we'd like to invite you to take a test drive. Your Mercedes-Benz dealer will be happy to make all the necessary arrangements for you. Simply visit www.mercedes-benz.com to locate the nearest Mercedes-Benz dealer in your country or region. We look forward to seeing you.

Interactive Owner's Manual. The website also offers an interactive tour, enabling you to take a closer look at your desired model. This simulation is the ideal way to acquaint yourself with your dream car. You can view key functions in detail, gain an insight into the car's inner workings or look at the benefits of each model. For further details, visit www.mercedes-benz.de/owners-manual

Mobile marketing. Now your mobile phone acts as a gateway to the whole Mercedes-Benz world. In addition to an overview of all passenger car models, there are insights into the entire brand world, not to mention a wealth of entertainment offers and direct links to a range of services at www.mercedes.mobi

Take-back of end-of-life vehicles. Coming full circle. At the end of its long life, you can return your E-Class to us for environment-friendly disposal in accordance with the EC End-Of-Life Vehicle Directive¹. But that day lies a long way off.

¹ Applies in accordance with national regulations to vehicles up to 3.5 tonnes gross weight. Mercedes-Benz passenger cars have met the statutory regulations governing the suitability of their design for reuse and recycling for a number of years now. A network of vehicle take-back depots and dismantlers has been established which will process your vehicle in an environment-friendly manner. The ways in which both vehicles and parts can be recovered are subject to ongoing development and improvement. Consequently, the E-Class will be able to comply with any future increases in the recycling quota within the stipulated time limits. For further information, please call 00800 1 777 7777.

Please note: changes may have been made to the product since this brochure went to press (31.12.2008). The manufacturer reserves the right to make changes to the design, form, colour and specification during the delivery period, provided these changes, while taking into account the interests of the vendor, can be deemed reasonable with respect to the purchaser. Where the vendor or the manufacturer uses symbols or numbers to describe an order or the subject of an order, no rights may be derived solely from these. The illustrations may show accessories and items of optional equipment which are not part of standard specification. Colours may differ slightly from those shown in the brochure, owing to the limitations of the printing process. This brochure has been compiled by Daimler AG of Germany and is distributed internationally. It provides a general indication of the range of models, features, optional extras and/or colours available in various countries. Some of the models, features, optional extras and/or colours shown may not be available in your country or may only be available in a different specification. Additionally some models, features, optional extras and/or colours may only be available in combination with others. For current and more specific information in relation to the range of models, features, optional extras and/or colours available in your country, and their pricing, you should contact your nearest authorised Mercedes-Benz Passenger Car Dealer. www.mercedes-benz.com