



**HYUNDAI** | NEW THINKING.  
NEW POSSIBILITIES.

**Technical Service Bulletin**

GROUP <b>STEERING</b>	NUMBER <b>14-ST-002-1</b>
DATE <b>MAY 2014</b>	MODEL(S) <b>SEE BELOW</b>

SUBJECT: **MOTOR DRIVEN POWER STEERING (MDPS) COUPLING REPLACEMENT**

**THIS TSB SUPERSEDES TSB 14-ST-002 TO ADD VELOSTER (FS) TO THE APPLICABLE VEHICLES LIST.**

**Description:** This bulletin describes the procedure to replace the flexible rubber coupling in the MDPS (motor driven power steering) assembly to address a minor “clicking” or “thud” type noise when turning the steering wheel in some models.

**\* NOTE**

**There are no steering performance issues associated with this condition.**



**Applicable Vehicles:**

- 2011~2014 Sonata (YFa), 2011~2014 Sonata Hybrid (YF HEV)
- 2007~2014 Elantra (HD, MD/UD), 2009~2012 Elantra Touring (FD), 2013~2014 Elantra GT (GD), 2013~2014 Elantra Coupe (JK)
- 2013~2014 Santa Fe (NC)
- 2012~2014 Azera (HG)
- 2012~2014 Veloster (FS)

**Parts Information:**

PART NAME	PART NUMBER	IMAGE	QTY
Flexible Coupling	56315-2K000-FFF	<p>Note: “4P” marking on revised part</p>	1

Circulate To: General Manager, Service Manager, Parts Manager, Warranty Manager, Service Advisors, Technicians, Body Shop Manager, Fleet Repair

**Warranty Information:**

Models	Op Code	Operation	Op Time	Causal Part #	Nature Code	Cause Code
YFa, YF HEV, FS, GD	56300F15	MDPS Flexible Coupling Replacement	1.5 M/H	56315- 2K000-FFF	N29	C06
NC	56300F16		1.6 M/H			
HD FD UD MD HG	56300F17		1.7 M/H			

**Service Procedure for Elantra (HD) and Elantra Touring (FD):**

**CAUTION**

- Take care to not damage any wiring or introduce foreign matter when disassembling the MDPS assembly.
- Ensure all connectors are securely plugged in when reassembling.
- Do not use a hoist when removing the MDPS assembly. Keep the tires on the ground during removal and installation of the MDPS assembly.

1. Remove MDPS assembly from the vehicle (refer to shop manual for removal procedure).

**\* NOTE**

Carefully align the steering wheel to the center position, with the front wheels pointing straight ahead before removing MDPS assembly.

When re-installing MDPS assembly, make sure the steering wheel is aligned to the center position, and that the front wheels are still pointing straight ahead.

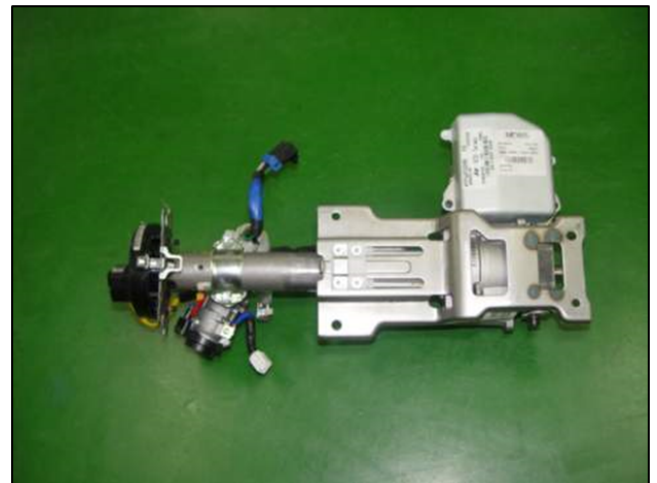

2. Remove the 4 steering column mounting bracket upper bolts (A).

**\* NOTE**

Tightening torque:  
A1) 2.2 lb-ft (2.9 Nm, 0.3 kgf.m)  
A2) 3.6 lb-ft (4.9 Nm, 0.5 kgf.m)

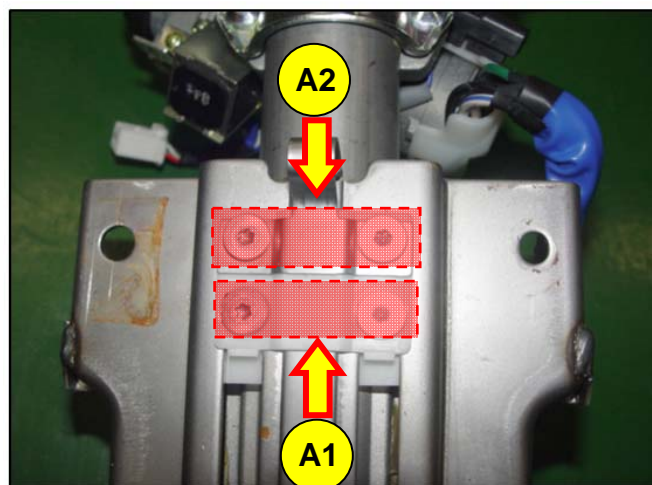
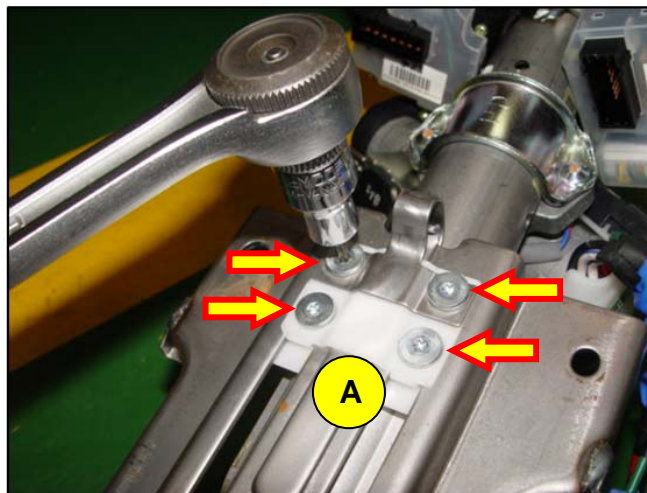

3. Raise the steering column mounting bracket and remove the spacer (B).

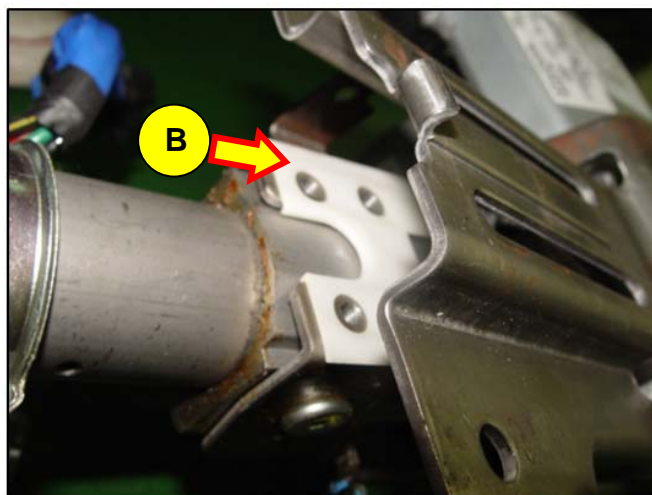

4. Remove the steering column bracket (C) from the MDPS assembly by loosening the bracket mounting bolt:

**\* NOTE**

There are 3 types of mounting bracket bolts (C). See steps 4a~4c for details on removal.

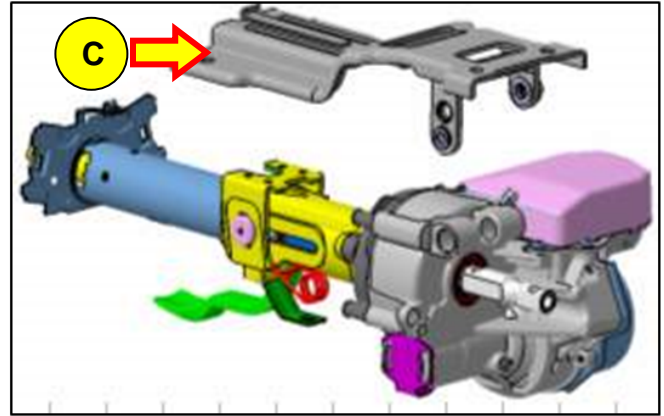

4a. **TYPE 1: STOPPER BRACKET (D)**

Remove the stopper bolt (E).

**\* NOTE**

Tightening torque:  
13.0~14.5 lb-ft (17.7~19.6 Nm, 1.8~2.0 kgf.m)

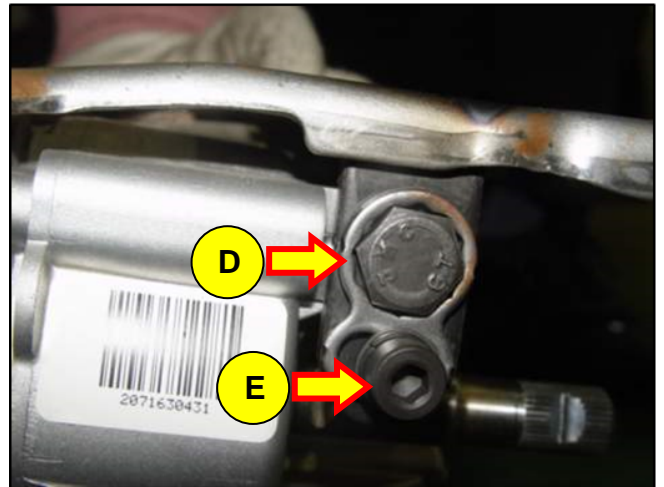

Remove the stopper bracket (D).

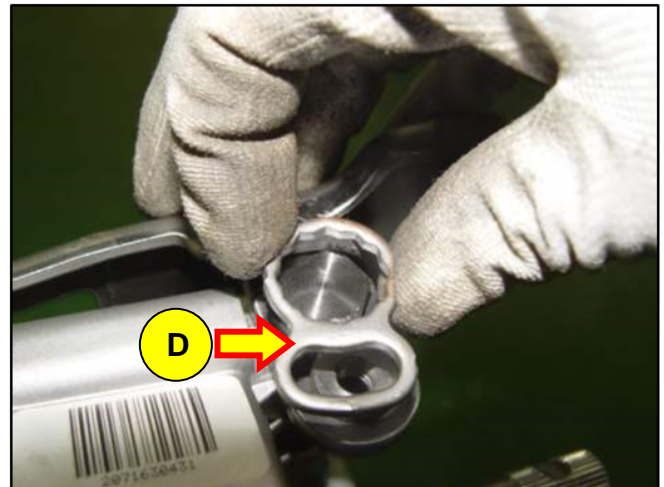

Remove the hinge bolt (F), then the column bracket (C) from the MDPS assembly.

**\* NOTE**

**Tightening torque:**  
7.2~10.1 lb-ft (9.8~13.7 Nm, 1.0~1.4 kgf.m)

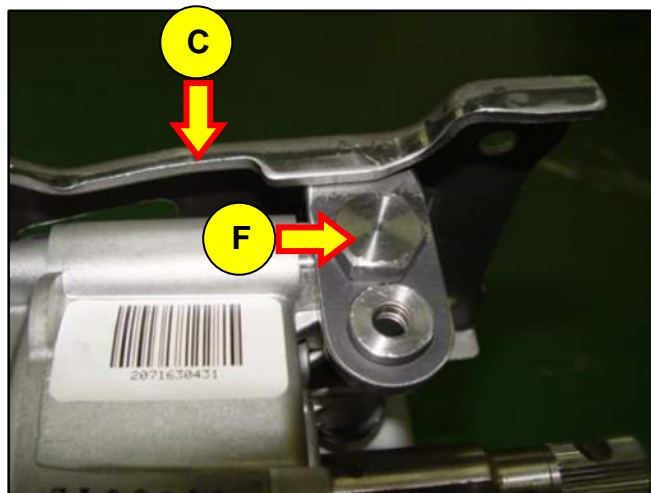

**4b. TYPE 2: MAIN HOUSING (G) AND PLASTIC BUSHING (H)**

Remove the hinge bolt (F), then remove the column bracket (C) from the MDPS assembly.

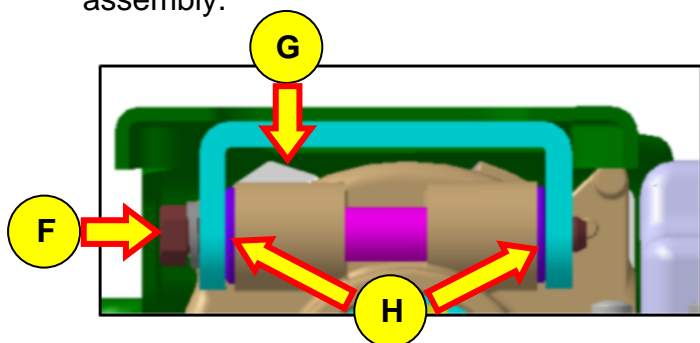

**\* NOTE**

**Tightening torque:**  
13.0~14.5 lb-ft (17.7~19.6 Nm, 1.8~2.0 kgf.m)

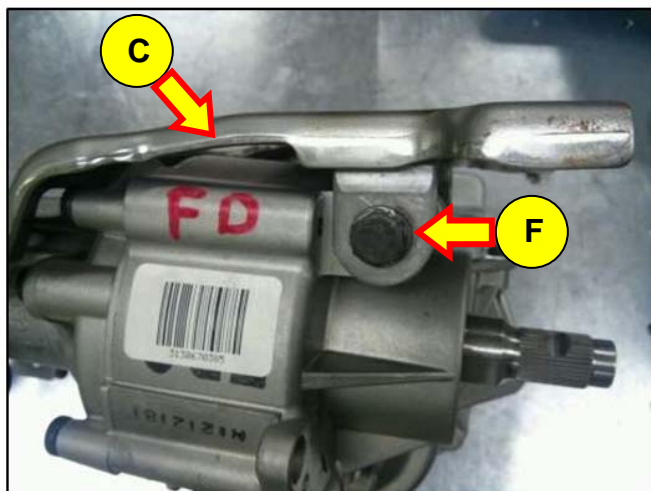



**4c. TYPE 3: MAIN HOUSING (G) ONLY**

Remove the hinge bolt (F) using a hexagonal wrench and then remove the column bracket (C) from the MDPS assembly.

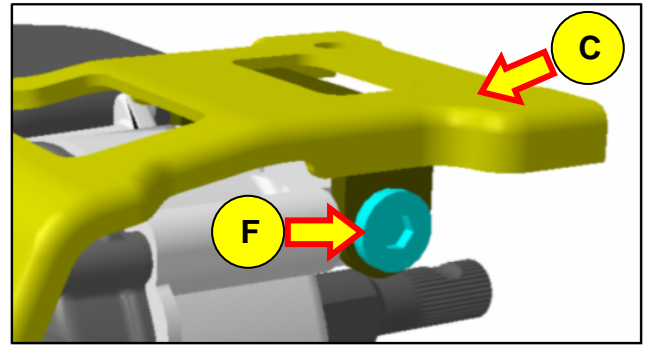
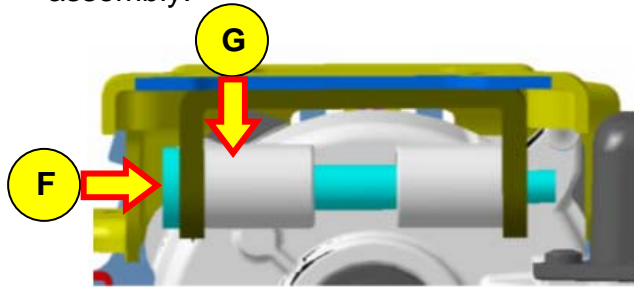

**5.** Set the MDPS assembly upright, as shown. Remove the four bolts (I), then separate the upper section from the lower.

**\* NOTE**

**Tightening torque:**  
**6.5~9.4 lb-ft (8.8~12.7 Nm, 0.9~1.3 kgf.m)**

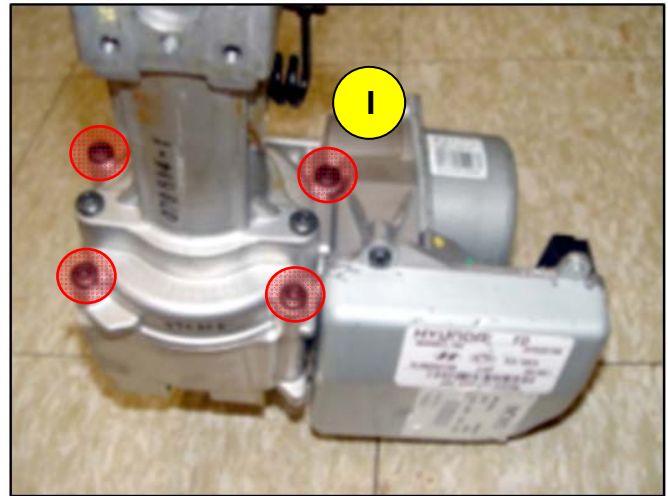

6. Remove the wave washer (J) and disconnect the sensor wiring connector (K).

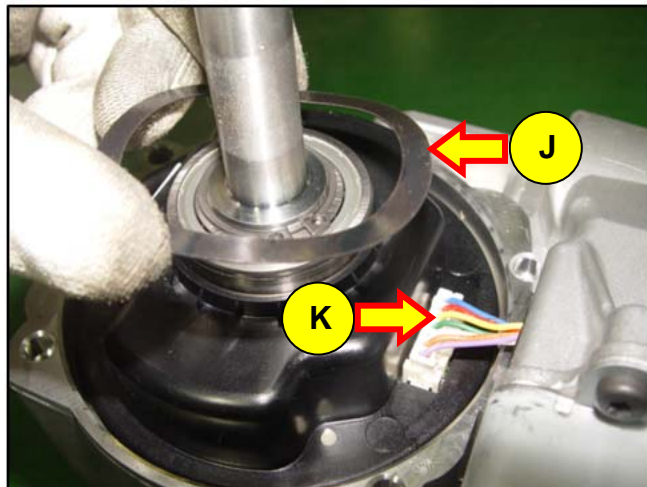

7. Remove the 3 MDPS ECU mounting bolts (L).

**\* NOTE**

**Tightening torque:**  
3.6~5.1 lb-ft (4.9~6.9 Nm, 0.5~0.7 kgf.m)



8. Loosen the 4 MDPS motor cover bolts (M) and then carefully lift off the motor cover (N).

**\* NOTE**

**Tightening torque:**  
3.6~5.1 lb-ft (4.9~6.9 Nm, 0.5~0.7 kgf.m)

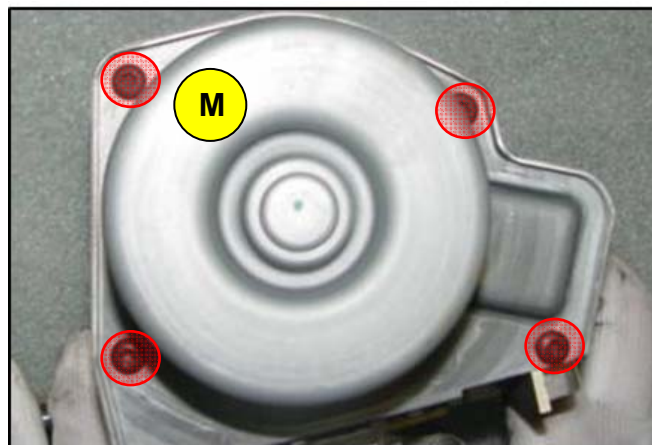

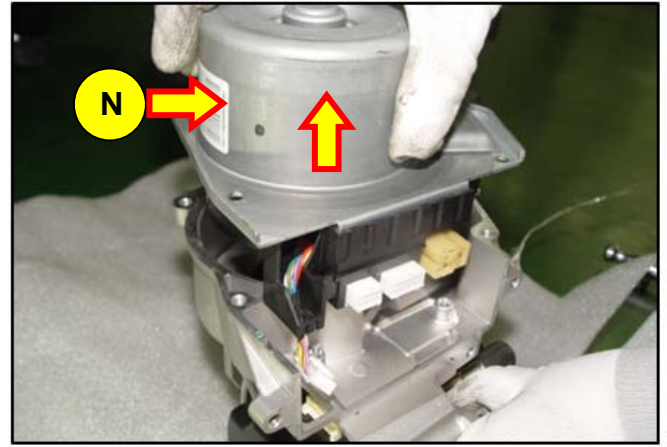

9. Remove the old flexible coupling (O) and clean out any debris.

**\* NOTE**

Clean out the coupling seating areas using a compressed air gun. Then remove any residual debris with a brush or clean rags.

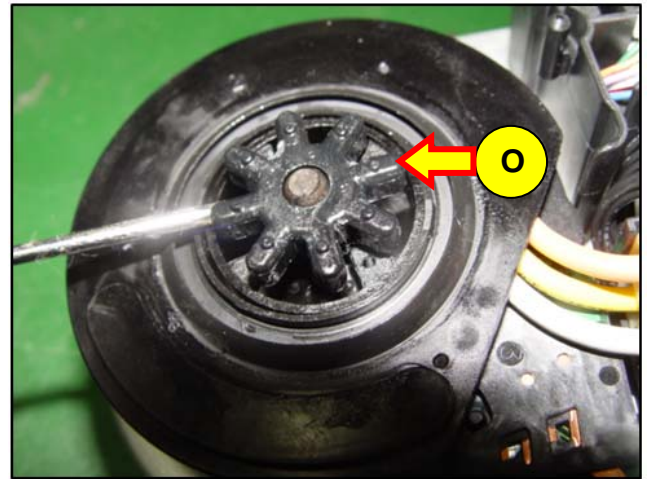

10. Install a new flexible coupling (P).

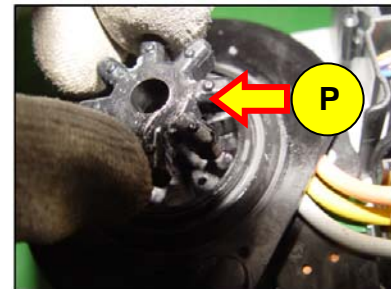
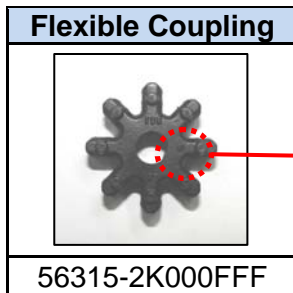

**\* NOTE**

- Before installing the new part, verify that it has the "4P" marking.
- Visually check that the coupler is seated properly before reassembling the motor.

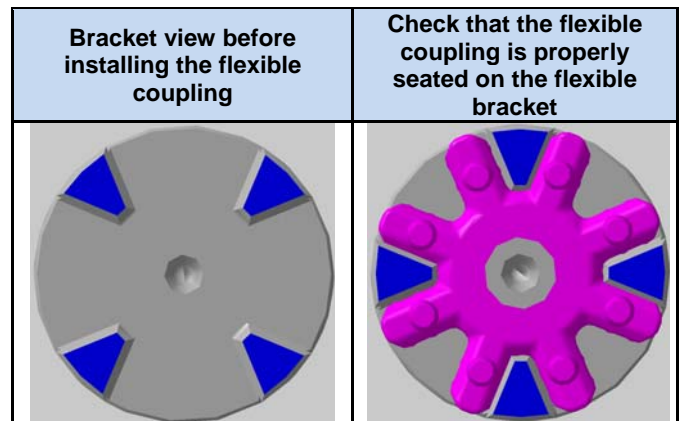



11. Reassemble the MDPS assembly in reverse order of disassembly.
12. Install the MDPS assembly back into the vehicle in reverse order of removal.
13. Conduct the ASP (Absolute Steering Position) calibration procedure according to the applicable service manual.
14. Check and clear any DTCs (Diagnostic Trouble Codes) using the GDS and confirm proper operation of the vehicle.

**Service Procedure for Sonata (YFa), Sonata Hybrid (YF HEV), Veloster (FS), Elantra (MD/UD), Elantra Coupe (JK), Elantra GT (GD), Santa Fe (NC), and Azera (HG):**



**CAUTION**

- Take care to not damage any wiring or introduce foreign matter when disassembling the MDPS assembly.
- Ensure all connectors are securely plugged in when reassembling.
- Do not use a hoist when removing the MDPS assembly. Keep the tires on the ground during removal and installation of the MDPS assembly.

1. Remove MDPS assembly from the vehicle (refer to shop manual for removal procedure).

**\* NOTE**

**Carefully align the steering wheel to the center position, with the front wheels pointing straight ahead before removing MDPS assembly.**

**When re-installing the MDPS assembly, make sure the steering wheel is aligned to the center position, and that the front wheels are still pointing straight ahead.**



- 2. Loosen the 3 bolts (A) to remove the MDPS motor using a T25 socket, or similar tool.

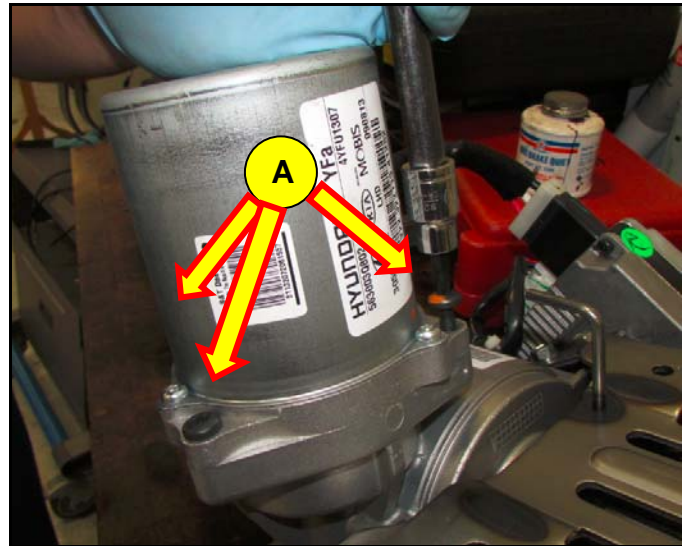

- 3. Remove flexible coupler (B).

**\* NOTE**  
Clean out the coupling seating areas (C) using a compressed air gun. Then remove any residual debris with a brush or clean rags.

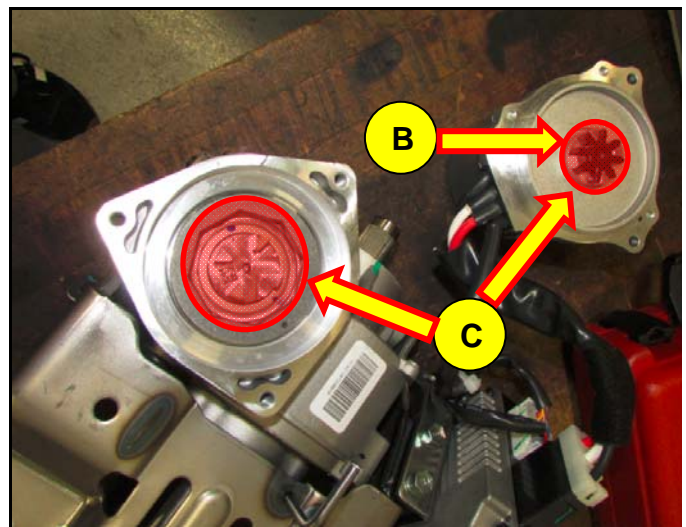

- 4. Install new flexible coupler (D) into MDPS assembly.

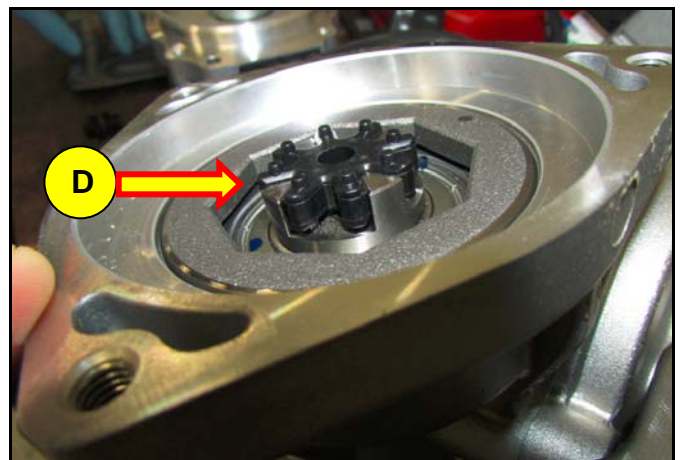
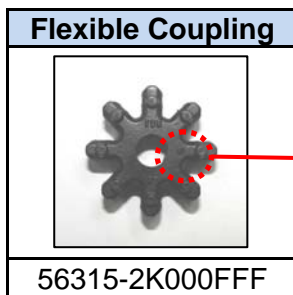

**★ NOTES**

- Before installing new part, verify that it has the “4P” marking.
- Visually check that the coupler is seated properly before reassembling the motor.

**Bracket view before installing the flexible coupling**

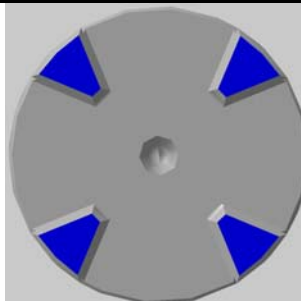

**Check that the flexible coupling is properly seated on the flexible bracket**

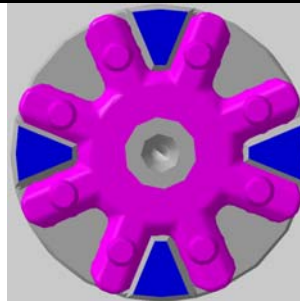

5. Install the motor back onto the assembly.

**★ NOTE**

**Tightening torque:  
5.8~8.7 lb-ft (7.84~11.76 Nm, 0.8~1.2 kgf.m)**



6. Install the MDPS assembly back into the vehicle in reverse order of removal.
7. Conduct the ASP (Absolute Steering Position) calibration procedure according to the applicable service manual.
8. Check and clear any DTCs (Diagnostic Trouble Codes) using the GDS and confirm proper operation of the vehicle.