

Cylinder Head Bolt Threads Damaged (2AZ-FE)

Service Category Engine/Hybrid System

Section Engine Mechanical

Market USA

Toyota Supports
 ASE Certification 

Applicability

YEAR(S)	MODEL(S)	ADDITIONAL INFORMATION
2002 – 2006	Camry	Engine(s): 2AZ Transmission(s): 4AT, 5MT, 5AT VDS(s): BE30K, BE32K WMI(s): 4T1, JTD
2001 – 2007	Highlander	Engine(s): 2AZ Transmission(s): 4AT, 5AT VDS(s): DD21A, GD21A, HD21A WMI(s): JTE
2004 – 2005	RAV4	Engine(s): 2AZ Transmission(s): 5MT, 4AT VDS(s): GD20V, HD20V WMI(s): JTE
2002 – 2006	Solara	Engine(s): 2AZ Transmission(s): 4AT, 5MT, 5AT VDS(s): CE22P, CE28P, CE30P, CE38P, FE22P, FE28P WMI(s): 4T1

Introduction

Some vehicles equipped with the 2AZ-FE engine may exhibit damaged cylinder head bolts. Please follow the Repair Procedure to install Time Sert[®] thread repair inserts into the cylinder block.

Warranty Information

OP CODE	DESCRIPTION	TIME	OFF	T1	T2
N/A	Not Applicable to Warranty	–	–	–	–

Cylinder Head Bolt Threads Damaged (2AZ-FE)

Parts Information

2002–2006 Camry

SPEC	PREVIOUS PART NUMBER	CURRENT PART NUMBER	PART NAME	QTY
PZEV & Non-PZEV	11400-28311	Same	Block Assy, Short	*
	90910-02141	Same	Bolt (for Cylinder Head Set)	*
	11213-0H010	Same	Gasket, Cylinder Head Cover	1
	11115-28040	Same	Gasket, Cylinder Head	1
	17173-28010	Same	Gasket, Exhaust Manifold to Head	1
Non-PZEV	17177-0H010	Same	Gasket, Intake Manifold to Head, No. 1	1
PZEV	17177-28040	Same	Gasket, Intake Manifold to Head, No. 1	1
	17171-28020	Same	Gasket, Intake to Exhaust Manifold	1
PZEV & Non-PZEV	90917-A6001	Same	Gasket, Exhaust Pipe	1

2002 – 2006 Solara

PREVIOUS PART NUMBER	CURRENT PART NUMBER	PART NAME	QTY
11400-28311	Same	Block Assy, Short	*
90910-02141	Same	Bolt (for Cylinder Head Set)	*
11213-0H010	Same	Gasket, Cylinder Head Cover	1
11115-28040	Same	Gasket, Cylinder Head	1
17173-28010	Same	Gasket, Exhaust Manifold to Head	1
17177-0H010	Same	Gasket, Intake Manifold to Head, No. 1	1
90917-A6001	Same	Gasket, Exhaust Pipe	1

Cylinder Head Bolt Threads Damaged (2AZ-FE)

Parts Information (Continued)

2001 – 2007 Highlander

PREVIOUS PART NUMBER	CURRENT PART NUMBER	PART NAME	QTY
11400-28311	Same	Block Assy, Short	*
90910-02141	Same	Bolt (for Cylinder Head Set)	*
11213-0H010	Same	Gasket, Cylinder Head Cover	1
11115-28040	Same	Gasket, Cylinder Head	1
17173-28010	Same	Gasket, Exhaust Manifold to Head	1
17177-0H010	Same	Gasket, Intake Manifold to Head, No. 1	1
17451-0D020	Same	Gasket, Exhaust Pipe	1

2004 – 2005 RAV4

PREVIOUS PART NUMBER	CURRENT PART NUMBER	PART NAME	QTY
11400-28311	Same	Block Assy, Short	*
90910-02141	Same	Bolt (for Cylinder Head Set)	*
11213-0H010	Same	Gasket, Cylinder Head Cover	1
11115-28040	Same	Gasket, Cylinder Head	1
17173-28010	Same	Gasket, Exhaust Manifold to Head	1
17177-0H010	Same	Gasket, Intake Manifold to Head, No. 1	1
17451-74040	Same	Gasket, Exhaust Pipe	1

* Order ONLY if engine block replacement is necessary.

Cylinder Head Bolt Threads Damaged (2AZ-FE)

Required Tools & Equipment

REQUIRED TOOLS & MATERIAL	QUANTITY
Brake Cleaner (for Cleaning Bolt Holes)	As Needed
Engine Oil (for Lubrication of Head Bolt Inserts)	As Needed
WD-40 [®] (for Lubrication of Core Drill and Tap)	As Needed
Power Drill	1
Tap Handle	1
Seal Tape (for Airtight Check of Bolt Holes)	As Needed
Shop Cloth (for Preventing Intrusion of Foreign Particles into Cylinder Block)	As Needed
Tape (for Preventing Intrusion of Foreign Particles into Cylinder Block)	As Needed

REQUIRED EQUIPMENT	SUPPLIER	PART NUMBER	QTY
Time Sert [®] M11 x 1.5 Universal Head Bolt Repair Kit (Includes 10 Thread Repair Inserts)	ADE	TFC2200	1
Time Sert [®] M11 x 1.5 x 30 mm Thread Repair Inserts		TFC11155	6
Loctite [®]		TFC6020	As Needed
Time Sert [®] Driver Oil		TFC6010	As Needed

NOTE

Additional Time Sert[®] kits and components may be ordered by calling Approved Dealer Equipment (ADE) at 1-800-368-6787.

Cylinder Head Bolt Threads Damaged (2AZ-FE)

Required Tools & Equipment (Continued)

Time Sert® M11 x 1.5 Universal Head Bolt Repair Kit

Figure 1. Kit Components Needed for Repair Procedure

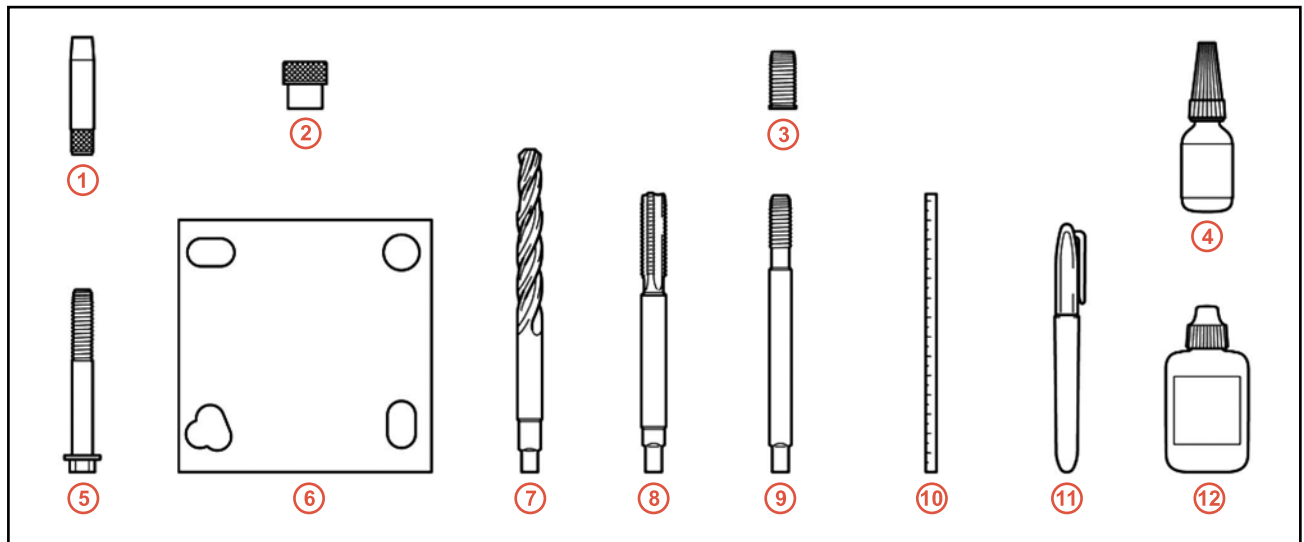

1	Alignment Pin (Line Pin)
2	Drill Bushing
3	Insert (x10)
4	Loctite®
5	Long Bolt (4.0 in.) (x2)
6	Drill Fixture

7	Core Drill
8	Tap
9	Insert Driver
10	Metal Rule
11	Ink Marker
12	Driver Oil

HINT

- Figure 1 shows the tools needed for this repair.
- The short Bolt (2.5 in.) and medium Bolt (3.5 in.) included in the kit are not needed for this procedure.

Cylinder Head Bolt Threads Damaged (2AZ-FE)

Repair Procedure Overview

1. Confirm the cylinder head bolt(s) is loose due to damaged threads.
2. Remove the short block assembly from the vehicle.
3. Inspect the cylinder block assembly for flatness to ensure it meets specifications for reuse.
4. Prepare the block for the insert repairs.
5. Use the core drill to repair the bolt holes.
6. Use the tap to cut new threads for the insert.
7. Use the insert driver to install the insert.
8. Reassemble and install the short block assembly with inserts installed.

Figure 2. Repair Procedure Work Flow

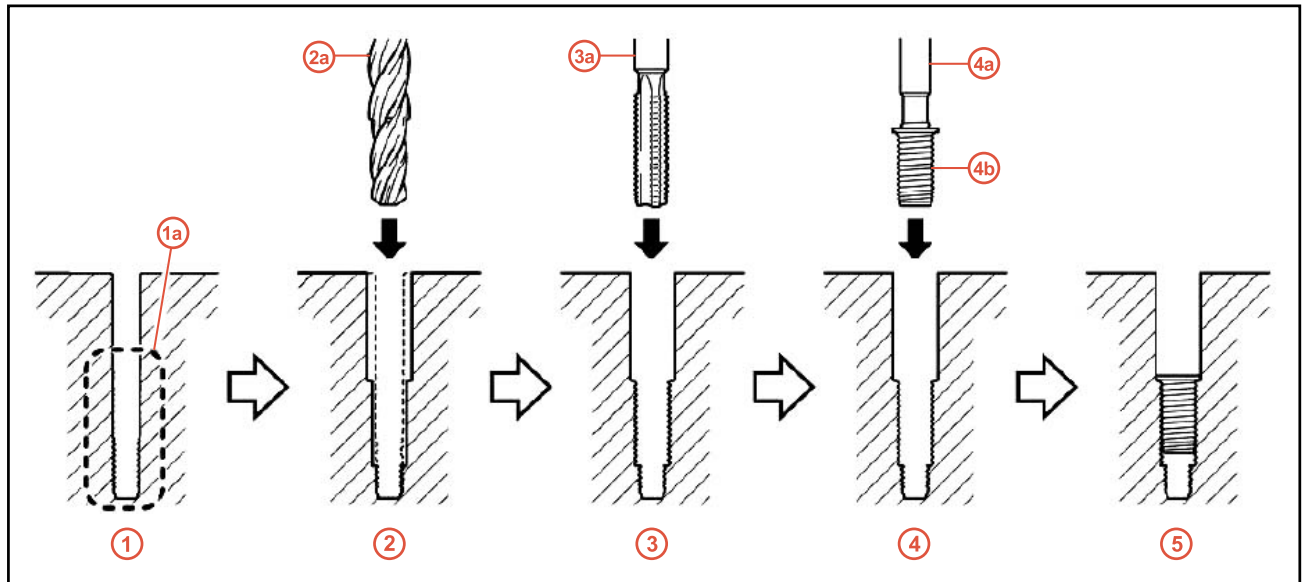

1	Before Work
1a	Damaged Threads
2	Repair Bolt Hole
2a	Core Drill
3	Cut New Threads for Insert

3a	Tap
4	Install the Insert
4a	Insert Driver
4b	Insert
5	Finished

Cylinder Head Bolt Threads Damaged (2AZ-FE)

Precautions for All Operations

CAUTION

- Protective goggles, a protective mask, and other necessary protective equipment must be worn while working.

Brake Cleaner:

- As brake cleaner is highly flammable, do not use it near fire or hot sections. If you get brake cleaner on your clothes, keep away from fire and hot sections until clothes are dry.
- Be careful to prevent spattering while working.
- For details, refer to the brake cleaner's handling instructions.

NOTICE

- Never perform insert work on the 2 bolt holes at the front and rear of the cylinder block. If any damage is found in such sections, replace the cylinder block.
- Make sure to perform insert work on all 6 holes regardless of the condition of holes (except 2 bolt holes front and rear of cylinder block).

Figure 3.

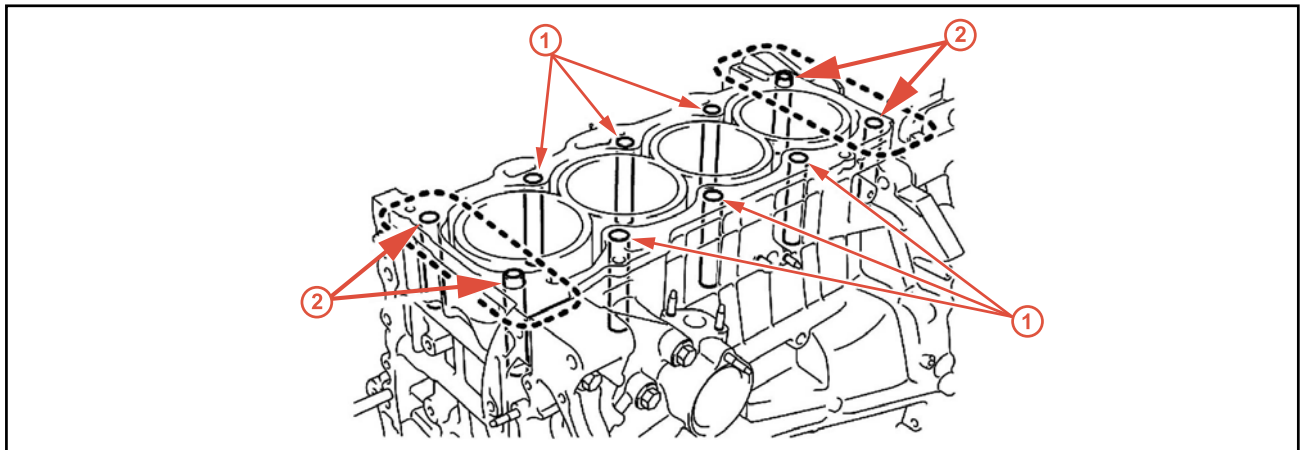

1 Inserts **MUST** Be Installed in These Holes

2 Inserts **CANNOT** Be Installed in These Holes

Cylinder Head Bolt Threads Damaged (2AZ-FE)

Inspection Procedure

1. Remove the engine assembly.

Refer to the applicable model and model year Repair Manual section(s) on the Technical Information System (TIS).

2. Disassemble the engine assembly to gain access to the cylinder block deck, cylinder head, and manifold mounting surfaces.

Refer to the applicable model and model year Repair Manual section(s) on TIS.

NOTE

If the following specifications are not met, replace the short block assembly.

3. Inspect the cylinder block for flatness.

Using a precision straight edge and feeler gauge, measure the surface contacting the cylinder head for warpage.

Maximum Warpage: 0.05 mm (0.002 in.)

Figure 4.

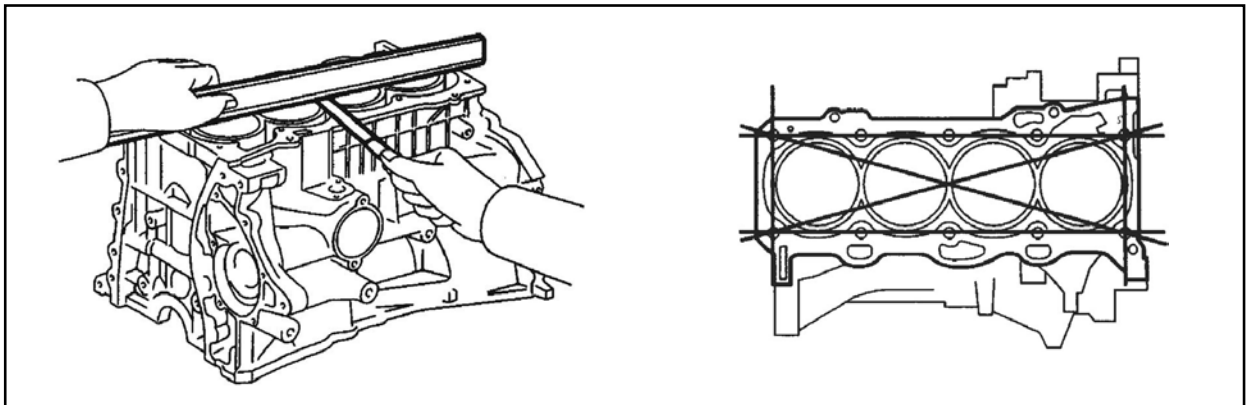

Cylinder Head Bolt Threads Damaged (2AZ-FE)

Inspection Procedure (Continued)

4. Inspect the depth of counter bore in head bolt hole.

Using a rule or vernier caliper, measure the depth of counter bore.

Maximum Depth: 79.0 mm (3.11 in.)

NOTICE

Replace the cylinder block if the depth of any head bolt hole exceeds the standard.

Figure 5. Head Bolt Hole

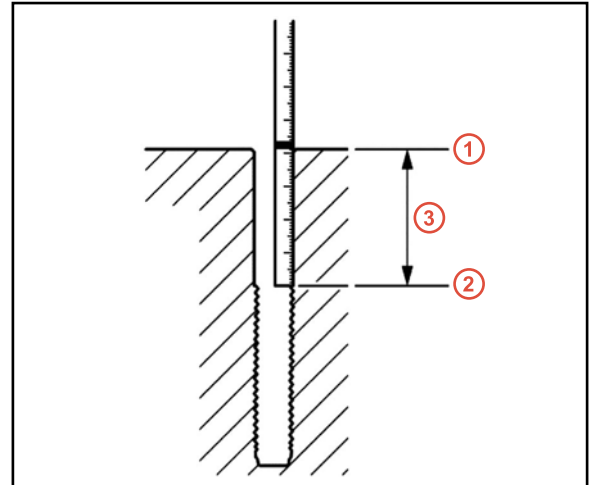

1	Top Surface of Cylinder Block
2	Start of Threads
3	Depth of Counter Bore

Cylinder Head Bolt Threads Damaged (2AZ-FE)

Inspection Procedure (Continued)

5. Inspect the cylinder head for flatness.

Using a precision straight edge and a feeler gauge, measure the surface contacting the cylinder block and the manifolds for warpage.

Maximum Warpage:

Cylinder Block Side: 0.05 mm (0.002 in.)

Exhaust Manifold Side: 0.08 mm (0.003 in.)

Figure 6.

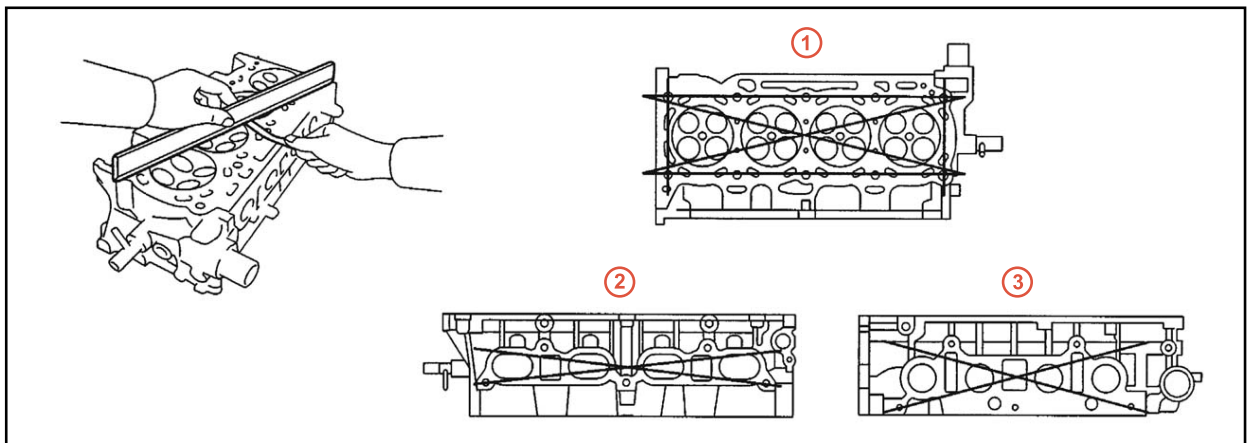

1	Cylinder Block Side
2	Intake Manifold Side

3	Exhaust Manifold Side
----------	------------------------------

6. Inspect the cylinder head set bolt.
 - A. Check that the thread of cylinder head set bolt is free of debris or other foreign materials. Clean the head bolt if necessary.
 - B. Using a vernier caliper, measure the length of the head bolts from the seat to the end.

Specified Bolt Length: 161.3 – 164.2 mm (6.35 – 6.46 in.)

Figure 7.

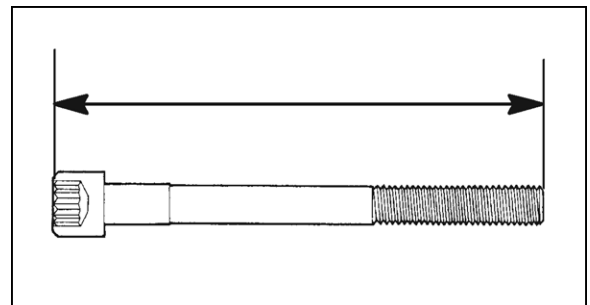

Cylinder Head Bolt Threads Damaged (2AZ-FE)

Repair Procedure

1. Attach the cylinder block to the engine stand and make sure that it can be rotated.

Figure 8.

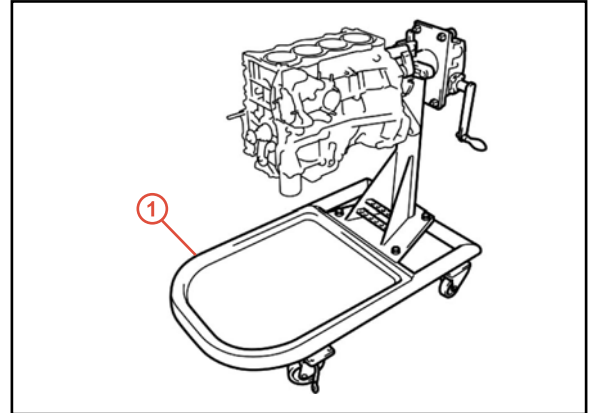

1	Engine Stand
----------	---------------------

2. Clean the tools.

Before beginning work, clean off any cutting particles or other substances from the tools which will be used.

Figure 9.

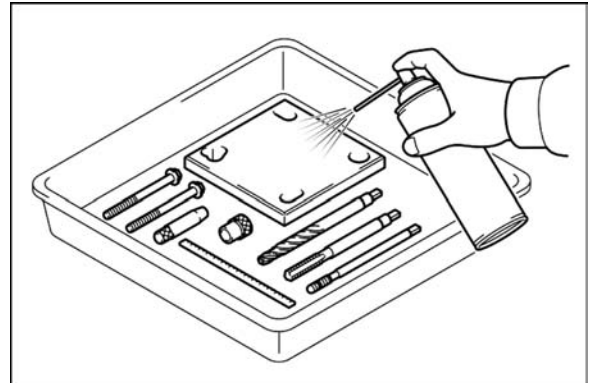

Cylinder Head Bolt Threads Damaged (2AZ-FE)

Repair Procedure (Continued)

3. Clean the cylinder block.
 - A. Remove the remaining gasket from the top surface of the cylinder block.
 - B. Remove any oil or other substances from the top surface of the cylinder block.

Figure 10.

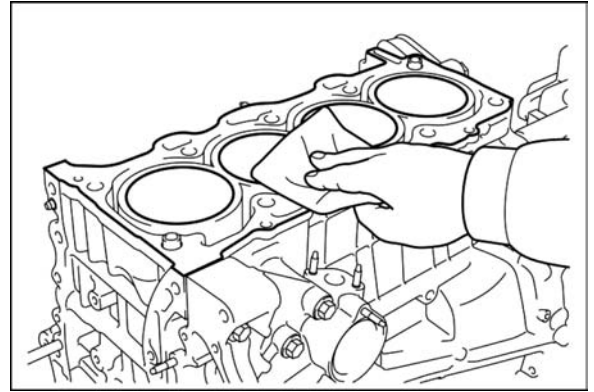

4. Mark the core drill positions.

Figure 11.

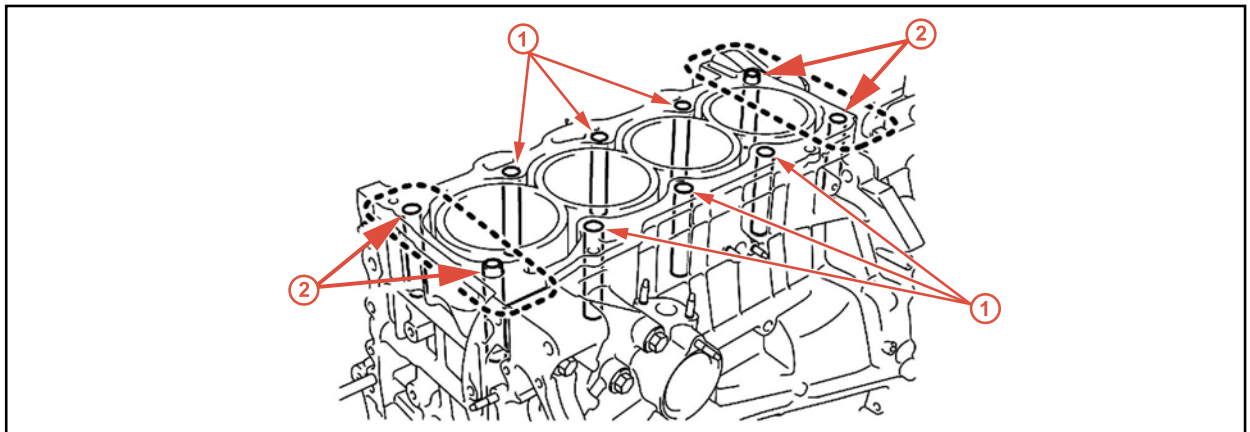

1 Inserts **MUST** Be Installed in These Holes

2 Inserts **CANNOT** Be Installed in These Holes

- A. Insert a rule into the bolt hole and place the end of the rule against the start of the threads.

Cylinder Head Bolt Threads Damaged (2AZ-FE)

Repair Procedure (Continued)

- B. Mark the position of the top surface of the cylinder block on the rule at this time, and record the dimension.

Dimension A: ____ mm (____ in.)

NOTICE

If dimension A exceeds 79 mm (3.11 in.), replace the cylinder block.

Figure 12.

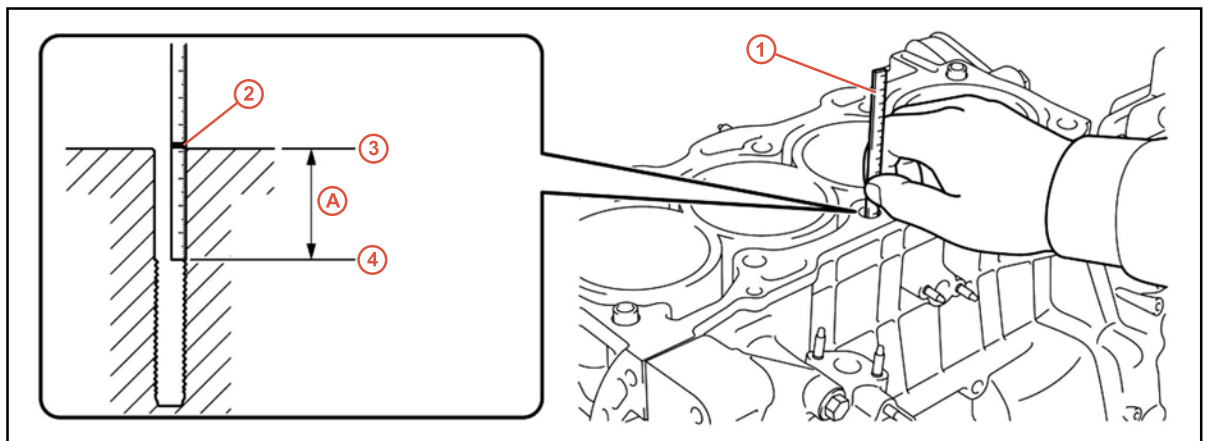

1	Metal Rule
2	Mark on Metal Rule
3	Top Surface of Cylinder Block

4	Start of Threads
A	Dimension A

- C. Insert the core drill into the drill bushing.

Cylinder Head Bolt Threads Damaged (2AZ-FE)

Repair Procedure (Continued)

- D. Align the rule, core drill, and bushing positions as shown in the figure. Mark the position of the top surface of the drill bushing on the core drill.

Marking position:
Height of Dimension A + Drill Bushing Height

Figure 13.

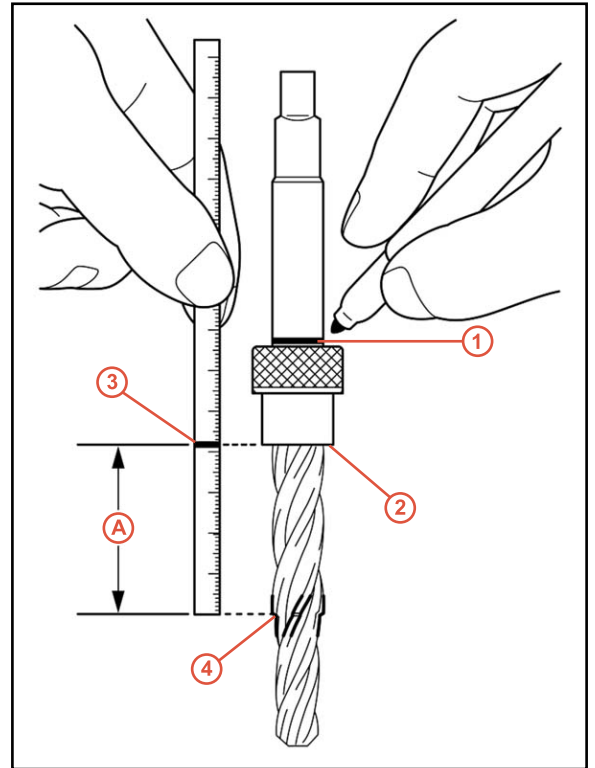

1	Marking Position
2	Lower Edge of Drill Bushing
3	Marking
4	Core Drill Step
A	Dimension A

Cylinder Head Bolt Threads Damaged (2AZ-FE)

Repair Procedure (Continued)

5. Mark the tap and insert the driver.
 - A. Align the front tips of the core drill, tap, and insert driver.
 - B. Mark the tap and insert driver at the same height as the marking on the core drill.

NOTE

Work carefully so the markings do not rub off during the repair.

Figure 14.

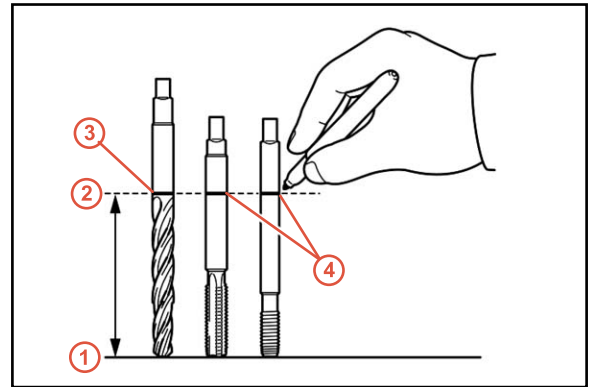

1	Align Front Tips
2	Same Height
3	Core Drill Marking
4	Mark on Tap and Insert Driver

Cylinder Head Bolt Threads Damaged (2AZ-FE)

Repair Procedure (Continued)

6. Provisionally install the drill fixture.

NOTICE

Move the pistons from the Top Dead Center position in order to avoid contact between pistons and drill fixture.

A. Install the drill bushing and alignment pin.

B. Align the round hole of the drill fixture with the bolt hole which will be repaired, and then temporarily install 2 head bolts to fix the drill fixture.

Figure 15.

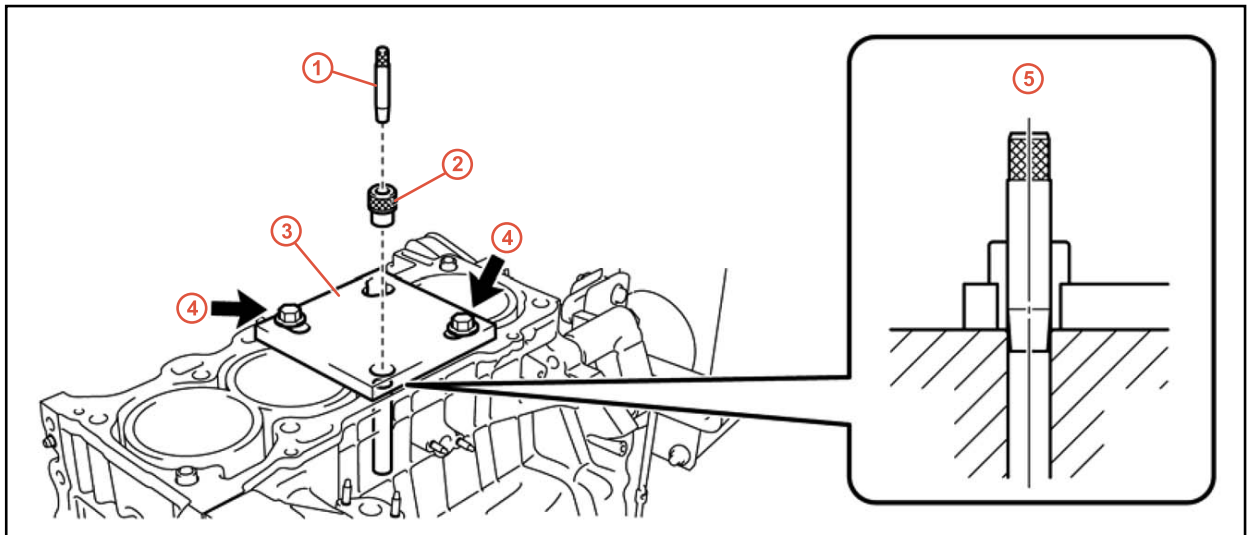

1	Alignment Pin
2	Drill Bushing
3	Drill Fixture

4	Provisional Installation
5	Align with Bolt Hole

NOTICE

- Always use 2 bolts to fix the drill fixture.
- Avoid using bolt holes with damaged threads for this procedure and install the bolts diagonally whenever possible.

Cylinder Head Bolt Threads Damaged (2AZ-FE)

Repair Procedure (Continued)

7. Center and fasten the drill fixture.

NOTICE

If the drill fixture is **NOT** correctly centered, the bolt holes may be drilled at an angle, and the cylinder block will need to be replaced.

- A. Press the alignment pin gently and make sure that the pin is inserted all the way down into the hole.

Figure 16.

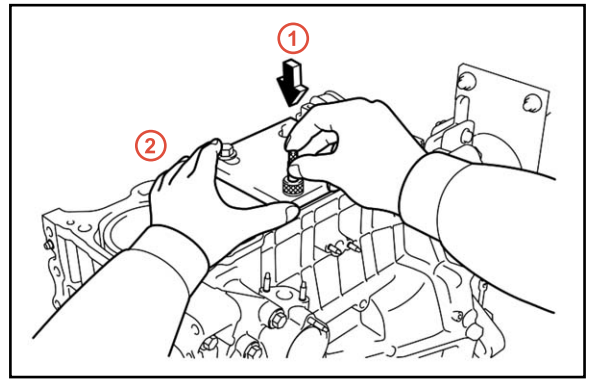

1	Press Gently
2	Align Position

- B. Hold the drill fixture so that it does not become displaced, and tighten the 2 bolts.

Figure 17.

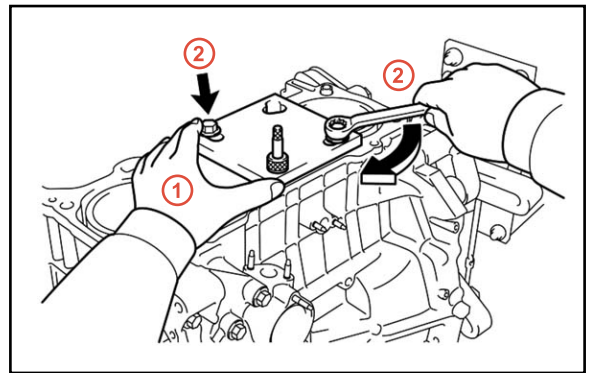

1	Hold
2	Tighten

- C. Remove the alignment pin, and visually check that the bolt hole and drill fixture are centered.

Cylinder Head Bolt Threads Damaged (2AZ-FE)

Repair Procedure (Continued)

8. Protect the cylinder block.

NOTICE

If the cutting particles that are produced during the drilling and tapping process enter the engine, they can cause engine damage, so be sure to apply protection.

Use tape or a shop cloth to cover the parts shown and protect the cylinder block so that cutting particles do NOT enter it.

- Drill fixture bolt holes
- Top surface of the cylinder block
- Cylinder block component installation holes

NOTICE

Use a new shop cloth and tape for each repair as the old ones may have cutting particles attached to them.

Figure 18.

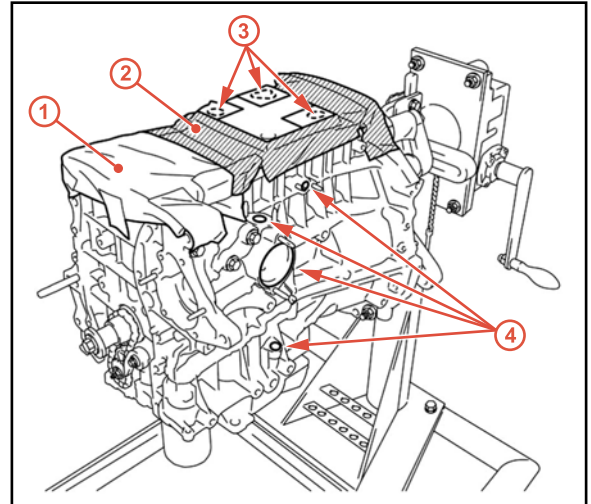

1	Shop Cloth
2	Tape
3	Bolt Holes
4	Component Installation Holes

9. Repair the bolt hole.

A. Tilt the cylinder block so that the cutting particles will fall downwards.

Figure 19.

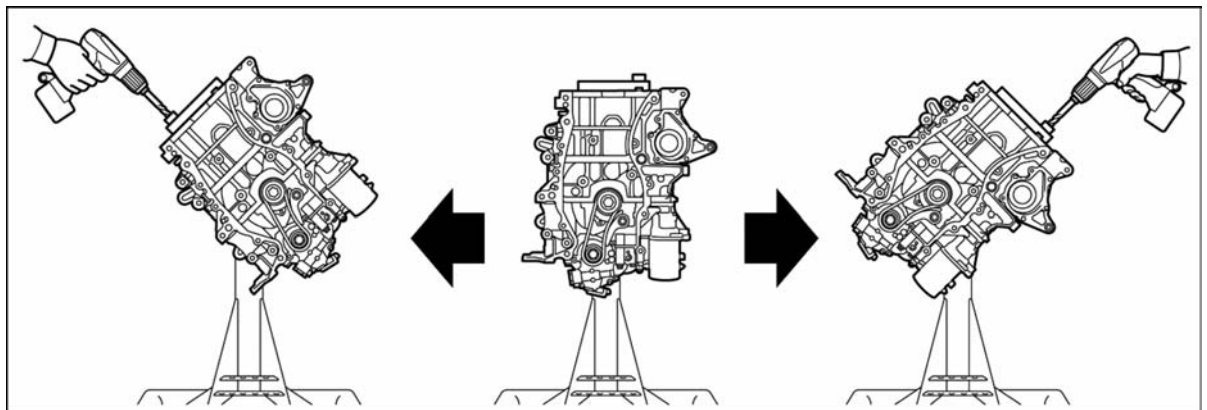

Cylinder Head Bolt Threads Damaged (2AZ-FE)

Repair Procedure (Continued)

B. Use the core drill and repair the bolt hole.

NOTICE

- Hold the drill perpendicular to the top surface of the block.
If the bolt holes are drilled at an angle, the cylinder block will need to be replaced.
- Drill the hole in 4 progressively deeper steps, retracting the drill each time, to clear the cutting particles from the hole.
- Apply WD-40® regularly to lubricate the drill.

Figure 20.

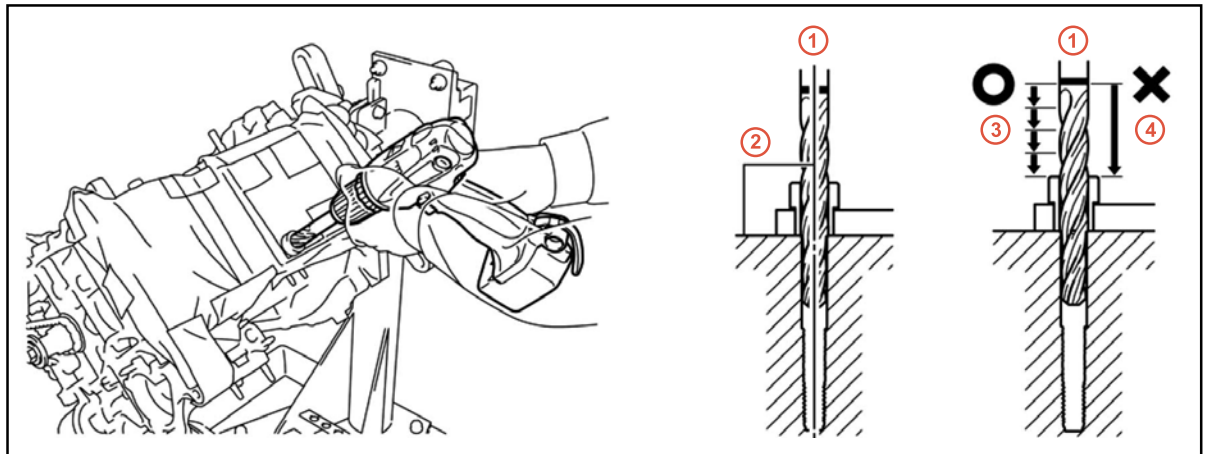

1	Core Drill
2	Perpendicular

3	Divide into 4 Steps
4	Do NOT Complete in One Step

C. Remove the core drill and drill bushing.

Cylinder Head Bolt Threads Damaged (2AZ-FE)

Repair Procedure (Continued)

D. Invert the cylinder block so that it is upside-down.

Figure 21.

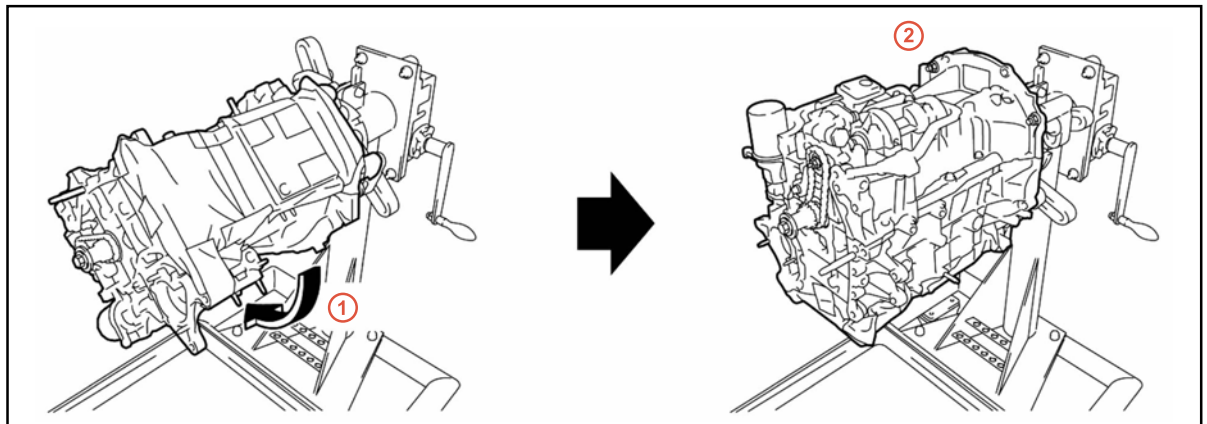

1 Invert

2 Clean with Block Inverted

E. Insert the nozzle all the way into the bolt hole and spray brake cleaner into the hole in order to flush out the cutting particles from inside it.

Figure 22.

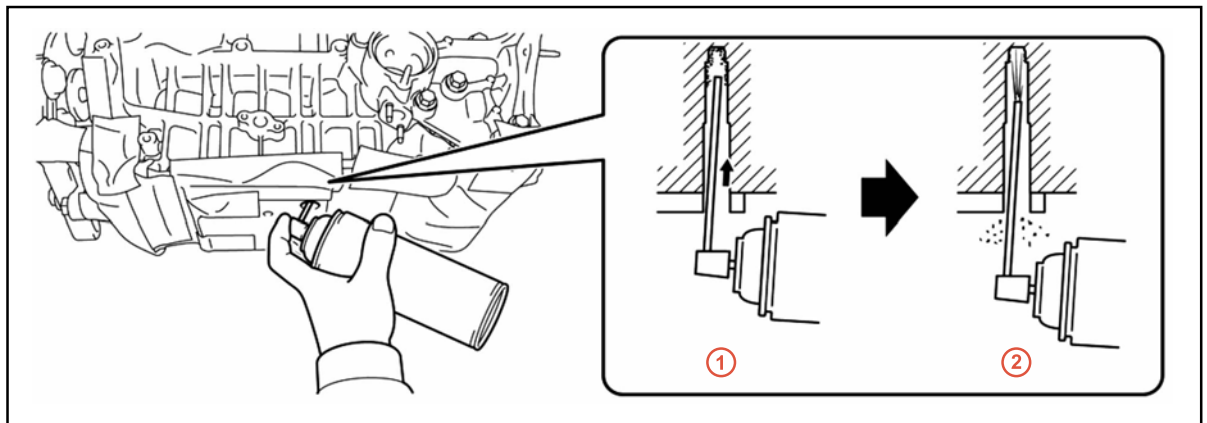

1 Insert All the Way to Bottom of Hole

2 Flush Out

Cylinder Head Bolt Threads Damaged (2AZ-FE)

Repair Procedure (Continued)

F. Return the cylinder block to a tilted position as shown in Figure 23.

Figure 23.

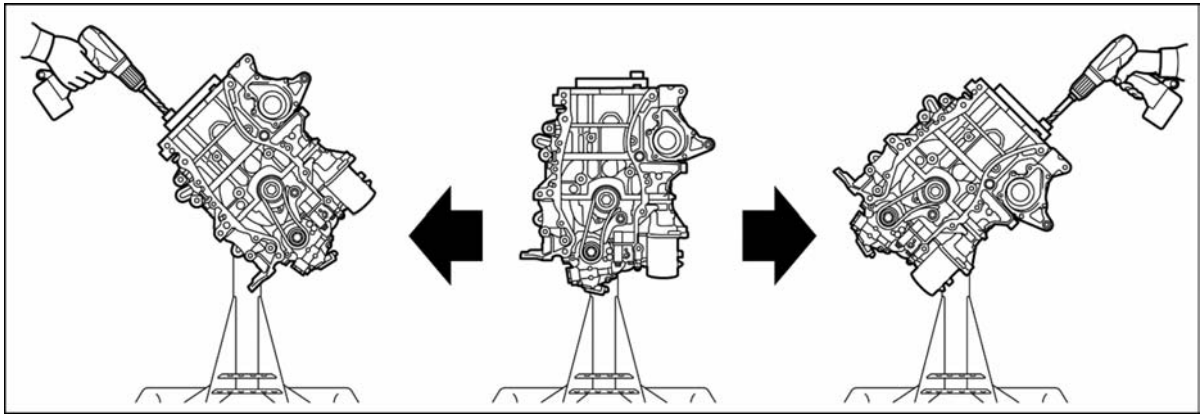

G. Repeat steps 9B through 9F until the marking on the core drill is aligned with the top surface of the drill bushing.

Figure 24.

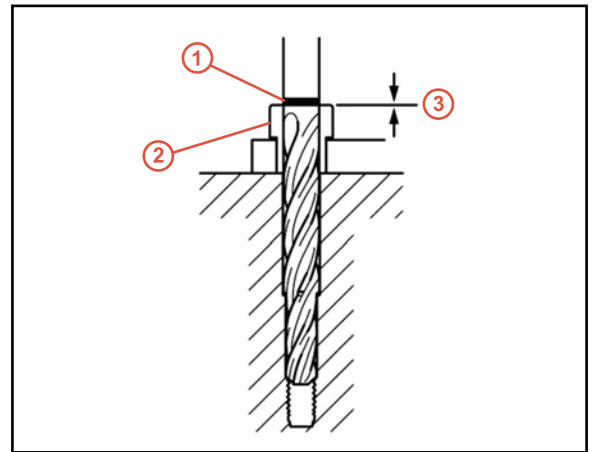

1	Marking
2	Drill Bushing
3	Marking and Top Surface of Drill Bushing Are Aligned

Cylinder Head Bolt Threads Damaged (2AZ-FE)

Repair Procedure (Continued)

10. Tap the bolt hole.
 - A. Position the cylinder block vertically.
 - B. Use the tap and tap handle to cut new threads in the bolt hole.

Figure 25.

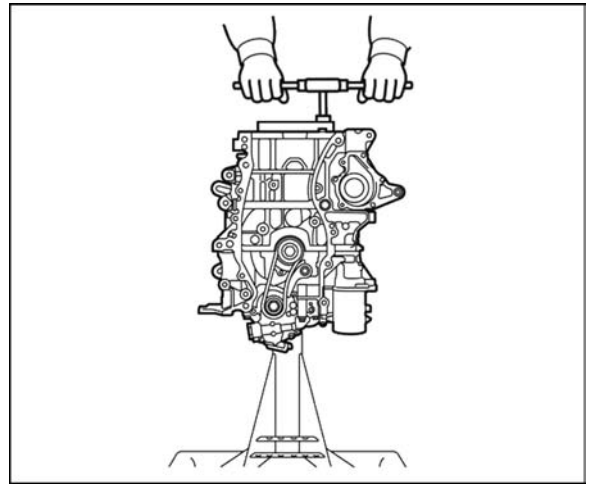

NOTICE

- Hold the tap perpendicular to the top surface of the block. If the bolt holes are tapped at an angle, the cylinder block will need to be replaced.
- Tap the hole in 4 progressively deeper steps, retracting the tap each time, to clear the cutting particles from the hole.
- Apply WD-40® regularly to lubricate the tap.

Figure 26.

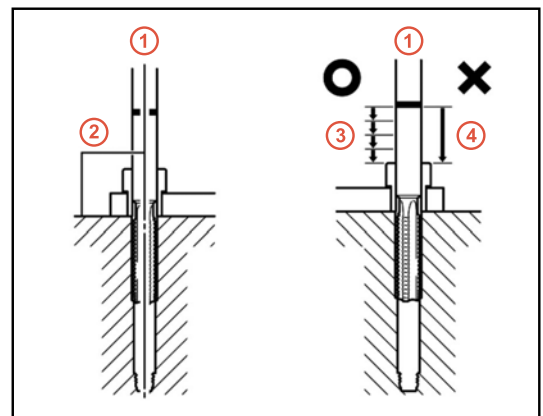

1	Tap
2	Perpendicular
3	Divide into 4 Steps
4	Do NOT Complete in One Step

- C. Remove the tap and drill bushing.

Cylinder Head Bolt Threads Damaged (2AZ-FE)

Repair Procedure (Continued)

D. Invert the cylinder block so that it is upside-down.

Figure 27.

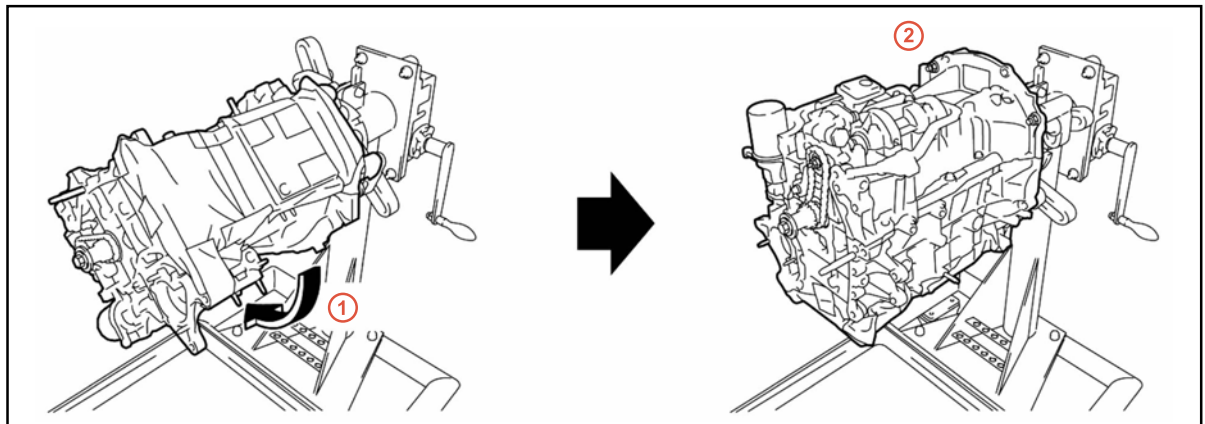

1 Invert

2 Clean with Block Inverted

E. Insert the nozzle all the way into the bolt hole and spray brake cleaner into the hole in order to flush out the cutting particles from inside it.

Figure 28.

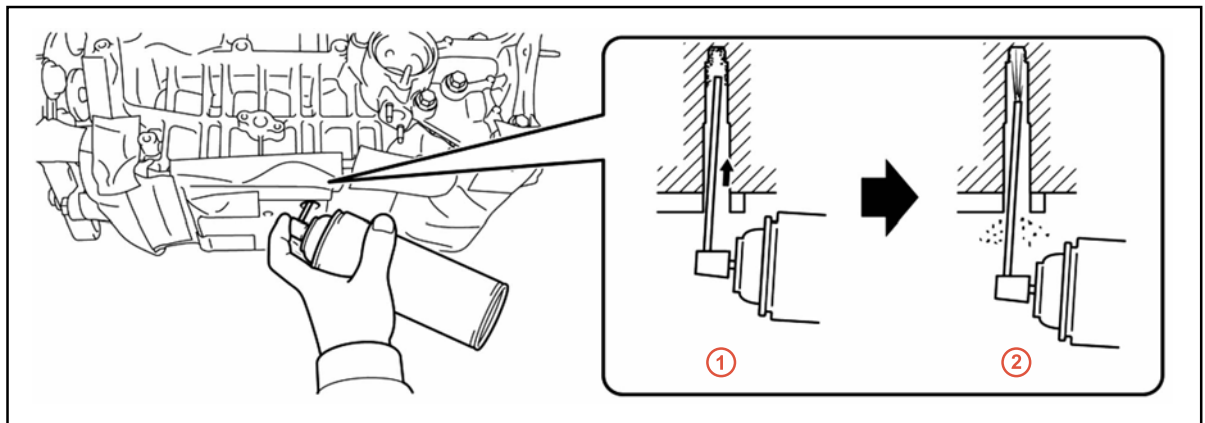

1 Insert All the Way to Bottom of Hole

2 Flush Out

Cylinder Head Bolt Threads Damaged (2AZ-FE)

Repair Procedure (Continued)

F. Return the cylinder block to a tilted position as shown in Figure 29.

Figure 29.

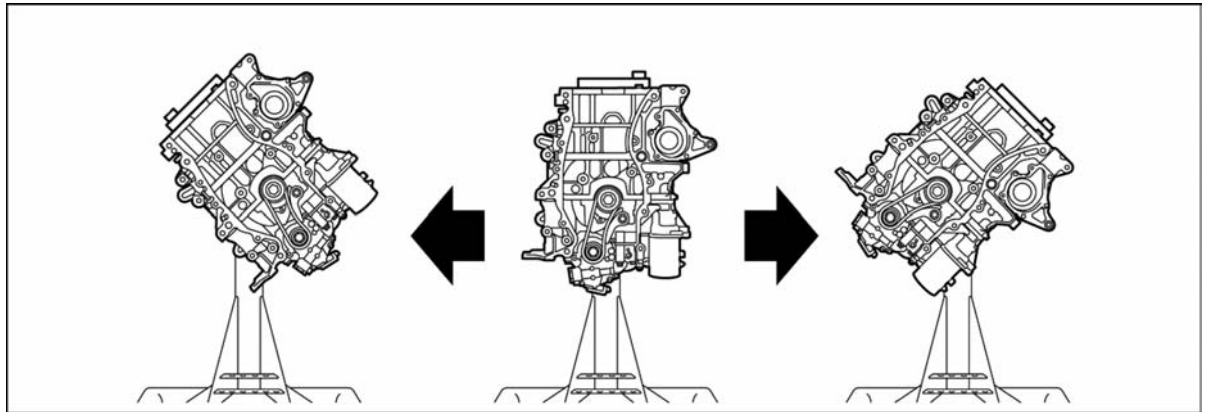

G. Repeat steps 9B through 9F until the marking on the tap is aligned with the top surface of the bushing.

Figure 30.

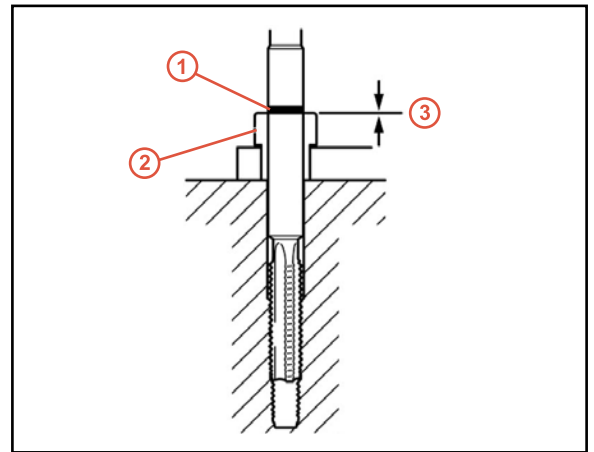

1	Marking
2	Drill Bushing
3	Marking and Top Surface of Drill Bushing Are Aligned

Cylinder Head Bolt Threads Damaged (2AZ-FE)

Repair Procedure (Continued)

11. Check the bolt hole.

A. Invert the cylinder block so that it is upside-down.

B. Insert the nozzle all the way into the bolt hole and spray brake cleaner into the hole in order to flush out the cutting particles from inside it.

Figure 31.

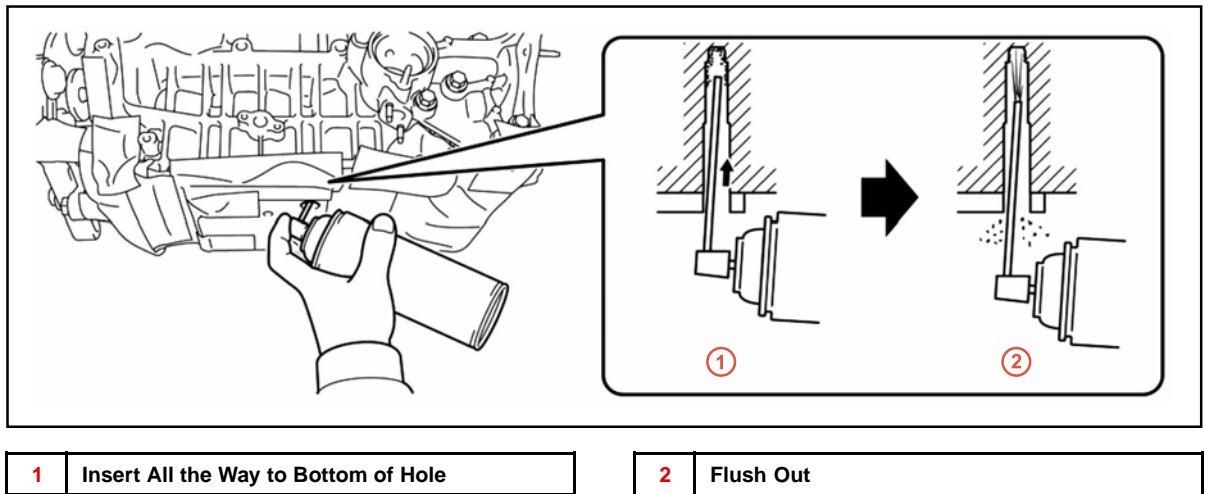

C. Use an air blower and dry the hole fully.

IMPORTANT

- Because Loctite® will be used to fasten the insert in place, be sure to dry the bolt hole fully.
- Position the cylinder block upside-down during this work.

Figure 32.

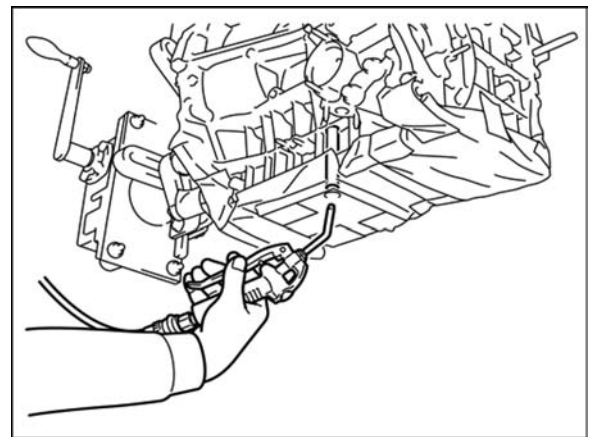

Cylinder Head Bolt Threads Damaged (2AZ-FE)

Repair Procedure (Continued)

D. Use a cylinder leak down tester and check the head bolt holes.

- (1) Wrap the tip of the tester with seal tape so it is thick enough to fill the gap between the tip of the tester and the holes.
- (2) Apply 44 psi (300 kPa) to the head bolt hole.
- (3) Confirm the air pressure does NOT decrease after 15 seconds.

NOTICE

- If air leaks through the head bolt hole into the short block, replace the cylinder block.
- Make sure to perform the leak check **BEFORE** inserting the insert to the bolt holes.

12. Install the insert.

A. Apply a small amount of driver oil to the threads of the insert driver.

Figure 33.

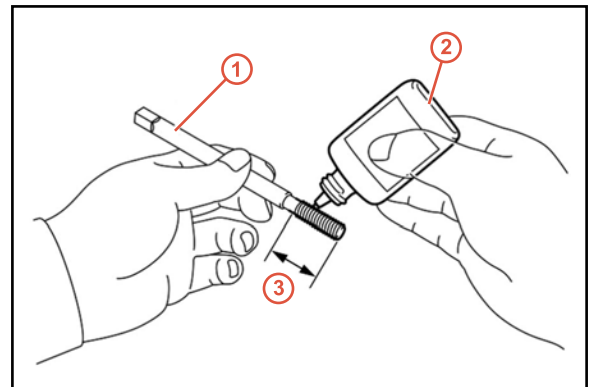

1	Insert Driver
2	Driver Oil
3	Threads

Cylinder Head Bolt Threads Damaged (2AZ-FE)

Repair Procedure (Continued)

- B. Screw the insert onto the insert driver all the way until it stops.

NOTICE

Do not apply oil to the outer threads of the insert.

Figure 34.

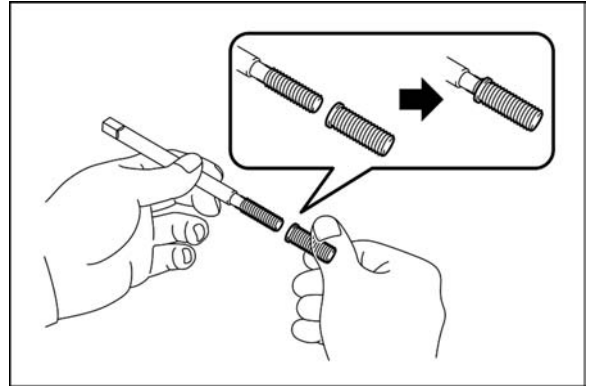

- C. Apply a small amount of Loctite® to the outer threads of the insert.

Figure 35.

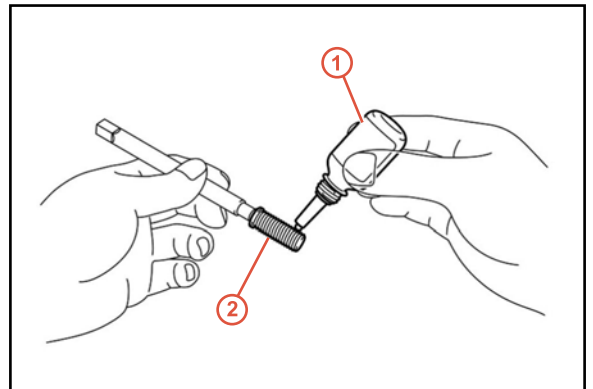

1	Loctite®
2	Insert

- D. Insert the insert driver with the insert into the bolt hole and slowly screw it into the hole until the marking on the driver matches the top surface of the drill bushing.

Cylinder Head Bolt Threads Damaged (2AZ-FE)

Repair Procedure (Continued)

- E. When the marking is aligned with the top surface of the bushing, turn the driver in the opposite direction to remove it.

Figure 36.

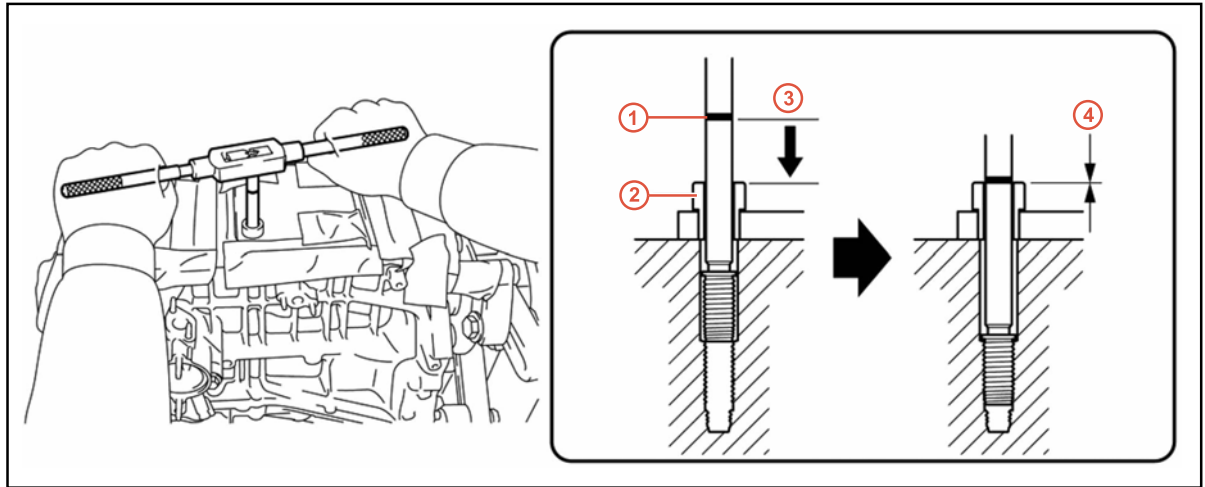

1	Marking
2	Drill Bushing

3	Screw in Slowly
4	Marking and Top Surface of Drill Bushing Are Aligned

- F. Remove the drill bushing and screw the head bolt into the hole by hand to verify that there is no problem with the threads.

Figure 37.

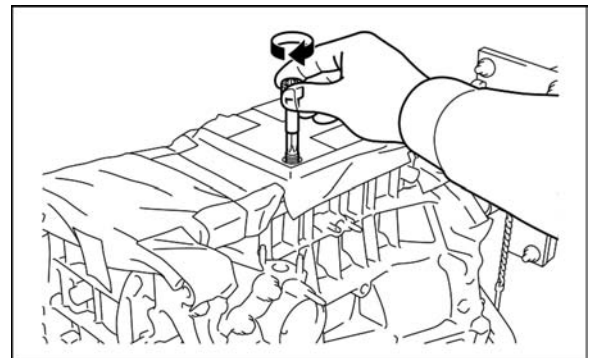

HINT

Apply a small amount of engine oil to the threads of the head bolt.

- G. Remove the shop cloth and protective tape.

NOTICE

Work carefully so the cutting particles do not fall on the engine.

- H. Remove the drill fixture.

Cylinder Head Bolt Threads Damaged (2AZ-FE)

Repair Procedure (Continued)

13. Repeat the insert installation process (steps 2 – 12) on the remaining bolt holes.

NOTE

The insert installation process MUST be performed on all 6 bolt holes regardless of the condition of the bolt hole. (See the Notice in “Precautions for All Operations” in this TSB).

14. Reassemble the engine assembly.

Refer to the applicable model and model year Repair Manual section(s) on TIS.

15. Install the engine assembly into the vehicle.

Refer to the applicable model and model year Repair Manual section(s) on TIS.

16. Test drive to confirm the repair.