



VOLVO XC90



THERE'S MORE TO YOU THAN LIVING LARGE. THERE'S GETTING WHERE YOU WANT TO GO. THERE'S GETTING THERE IN STYLE AND COMFORT. THERE'S POWER, AGILITY AND UNRESTRICTED PLEASURE. AND THERE'S DESIRE. DESIRE TO ENJOY THE BEST AND DESIRE TO SHARE THIS WITH THOSE YOU LOVE, NO MATTER WHERE YOUR JOURNEY TAKES YOU. THAT'S WHY THERE'S THE XC90. THAT'S WHY YOU DRIVE ONE.

CONTENTS

THE VOLVO XC90

Driver's environment	6
Passenger comfort	8
In-car entertainment	12
Performance	14
Personal security	16
Safety & Environment	18

YOUR VOLVO XC90

Engines & Equipment	22
Exterior colours	24
Exterior design	26
Executive	28
R-DESIGN	32
Features, Options & Accessories	34

www.volvocars.com.au



The subtle application
of pure strength.

The seven seat XC90, a superb family SUV with style and muscle. But the application of power without discrimination has never been our business, and here you'll find no exceptions. Among a wealth of outstanding performance enhancing technology you'll find features such as AWD with Instant Traction and six-speed Geartronic transmission with a winter setting.

Harmonising power with subtlety can be a bridge too far for many SUVs. But with one depression of the accelerator pedal on an XC90, you'll feel equal part of muscle and grace and instantly enjoy what is surely one of nature's most potent combinations.



Expect more and that's exactly what you'll get.



As you settle back into the sumptuous Leather interior, let the waves of music from the Premium Sound music system wash over you and experience the relaxed power of a sophisticated turbodiesel or an in-line six-cylinder petrol engine, we suggest you try this short mental exercise.

Look around you. Feel the contentment from your companions. Take a deep breath. Then try to remember what you once called expectations.



SRS AIRBAG

Our designers are dreamers – are you?

Have you ever dreamt of a car that is as big as your life? A car with a choice of interior packages, each one an impeccable reflection of contemporary auto styling? Features that are as intuitive as they are facilitating and performance that takes you effortlessly from town to dirt track? We did. And we decided to share it with you. Why not climb in and join us in Dreamland?



64 expressions
of versatility.

Every one of the seven seats in the Volvo XC90 offers much more than superb comfort. They can also be configured in 64 different ways. Add the fact that every passenger seat can be folded flush and you have the perfect marriage of versatility and luxury. Loading is an easy job too – just open the liftgate section of the split tailgate for lighter objects or let both sections open wide for heavier loads.



When was the last time
you felt music?

There is one sure way to transform a journey into an event – add some good music. If you can do this through a system that leads the way in audio excellence, all the better.

Volvo's Premium Sound system delivers a seriously moving aural experience. It features a digital class D amplifier, 12 high end loudspeakers and Dolby® Pro Logic® II surround sound and is fully compatible with your iPod® or MP3 player. We could say more but in this case, we'll let the music do the talking.



It takes extraordinary character to shoulder big responsibility.

Engine power and an improved environment. To many, these terms sound like a contradiction. To us, they represent a call to action.

The challenge is to develop technology that doesn't compromise on performance while at the same time acknowledging our environmental responsibility. The result is a series of diesel and petrol engines that break the mould, like the six-cylinder 3.2 AWD with Variable Cam Timing and Cam Profile Shifting to optimise performance and fuel economy. This engine is a compact yet formidable power source. It provides up to 320 Nm of torque intelligently distributed to all four wheels with smooth, responsive acceleration for a relaxed yet exhilarating drive.

Carrying this power also presented challenges of its own. To meet these, design characteristics such as a low centre of gravity, precisely calculated weight distribution and high ground clearance were applied. As a result, you stay firmly and comfortably rooted to the road, no matter where it's taking you.



Sometimes a reduced pulse rate is preferred.

In the case of the Volvo XC90, relaxation is a state of mind not exclusive to driving or enjoying the ride. Leave this car and you'll be able to enjoy the same feeling. Tough door locks, an electronic immobiliser and laminated side windows help keep unwanted visitors at bay. Approach and Home Safe lighting provide welcome reassurance when entering and leaving the car in unlit areas.

Wherever it takes you, this SUV has the capacity to get your pulse racing. But when it comes to security, you'll be pleased to know it does exactly the opposite.



INNOVATED FOR YOUR ENJOYMENT, VOLVO SAFETY TECHNOLOGIES WILL PROTECT MORE THAN THE FUN OF DRIVING.

Across the world Volvo is synonymous with advanced safety technology. And with good reason, because few car makers can match our record of safety innovations and the commitment to safety that has guided us for more than 80 years. Of course, this makes us extremely proud. But we're not satisfied. Because we know what we want to achieve: zero accidents. This huge task calls for innovative thinking and a brand-new approach to the way we design cars. The good news is that we've already come a long way. For starters, our cars are more fun and engaging to drive than ever. And the technology needed is no figment of the imagination – some is already available in your Volvo. This means driving a Volvo today is like having a first peek at a very exciting automotive future – a future where passionate engineering and design do more to empower you as driver.



EYES IN THE BACK.

Park Assist and Park Assist Camera let you know what's going on behind your car when reversing.

ALL-ROAD STABILITY.

Volvo's All-Wheel Drive (AWD) with Instant Traction™ enhances driving stability and traction in all weathers, in all seasons and on all roads.

STAY ON TRACK.

Volvo's anti-skid system Dynamic Stability and Traction Control (DSTC) improves handling and safety in a wide range of challenging situations.

RAINPROOF.

Water-repellent side windows improve vision in the rain, and a rain sensor automatically engages the wipers if it begins to rain or if water splashes onto your windscreen.

KEEP THE BALANCE.

Roll Stability Control (RSC) senses an impending rollover and helps stabilise the vehicle if needed.

EXHILARATING COMFORT.

Ergonomic design in seats and the driver's environment makes you relaxed and helps maintain your concentration on driving.

AN EYE ON THE BLIND SPOT.

The Blind Spot Information System (BLIS) helps you detect vehicles entering your blind spot.

ON-ROAD ENLIGHTENMENT.

Active Bending Lights (ABL) with Dual Xenon technology expands your vision range when driving in the dark and provides considerably improved illumination around bends.

DESIGNED TO CATCH THE LIGHT BRILLIANTLY, A VOLVO ALSO REFLECTS A PROMISE.

Our journey towards a better environment started back in the early 70s. Then we were among the first car makers to acknowledge the environmental downside of cars and to do something about it. Since then we have been constantly innovating to reduce the environmental impact of our cars – all the way from product development and manufacturing to driving and recycling.

One of our biggest challenges is to reduce CO₂ emissions, which contribute to climate change. Our response is the technology and innovations developed within our DRIVE environmental program. For example, today we offer one of the premium segment's strongest ranges of low CO₂ alternatives. And consistently utilising innovative powertrain technology together with advanced aerodynamics, low friction technology and lightweight materials, DRIVE is an important step towards zero emissions.

In the near future we will be introducing new technology such as plug-in hybrid vehicles that will further reduce CO₂ emissions and can be charged from a standard wall socket. And we're heavily engaged in the development of electric vehicles – a technology that will dramatically reduce the environmental footprint of our cars and make them even more fun to drive. Fact is, we have already launched our first electric car – the Volvo C30 Electric – and more exciting news is on the way.

FRESH CABIN AIR.

Continuously monitoring the incoming air and shutting out carbon monoxide, ground-level ozone and nitrogen dioxide, Volvo's Interior Air Quality System (IAQS) helps ensure that the air you breathe in the car is cleaner than the air outside when driving in heavy city traffic.

85% RECYCLABLE.

To help minimise its total environmental impact, every Volvo is designed to facilitate recovery and recycling at the end of its useful life.

CLEANER EXHAUST.

Fast responding after a cold start, Volvo's advanced emission control eliminates between 95 and 99% of carbon monoxide, hydrocarbons and nitrogen oxides from petrol engine exhaust gases. The Volvo turbodiesels feature a particulate filter that removes about 95% of the particles from the diesel exhaust gases.

FROM 104 G CO₂ PER KM.

Our most eco-progressive engine alternatives, the CO₂ optimised Volvo DRIVE Start/Stop, are designed for best-in-class fuel efficiency – for minimum emissions and maximum style.



ALLERGY-APPROVED INTERIOR.

Clean Zone Interior Package (CZIP) provides cabin air that is so clean it is recommended by the Swedish Asthma and Allergy Association.

HEALTHIER INTERIOR MATERIALS.

All our upholstery and interior textiles are tested for specific allergy-inducing or harmful substances. And several interior metal details are tested with regard to contact allergies.

BIOETHANOL FOR LOWER FOSSIL CO₂ EMISSIONS.

Running on E85 bioethanol in a Volvo Flexifuel, you can significantly cut your greenhouse gas emissions. Because bioethanol is a renewable fuel, the carbon dioxide emissions from combustion are already part of the ecosystem and won't contribute to greenhouse gas levels in the atmosphere.

FUEL-SAVING DESIGN.

To reduce energy loss from air and roll resistance, we utilise advanced aerodynamic design, lightweight materials and low-friction technology. Together with state-of-the-art engine technology, this lowers your CO₂ emissions and helps you travel further on less fuel.

BRAKE FOR ENERGY.

For most of the engines, the battery is fed with extra power every time you brake. Smart and fuel-saving.

GREEN AT THE RED LIGHTS.

To further reduce fuel consumption and CO₂ emissions by up to 8% when driving in town, several engines feature Volvo's new Start/Stop technology.



PETROL ENGINE

3.2 AWD

auto
 269 CO₂ g/km
 11.5 l/100 km
 179 kW
 320 Nm

DIESEL ENGINE

D5 AWD

auto
 233 CO₂ g/km
 8.8 l/100 km
 147 kW
 420 Nm

THE CREATION OF YOUR VOLVO STARTS UNDER THE BONNET. A major part of the experience ahead of you is defined by the engine you choose. Is it maximum performance and a sporty engine character that make your heart tick? Or do you prefer relaxed cruising and the highest possible fuel mileage? Whichever engine satisfies your requirements, you will enjoy instant power and smooth running while state-of-the-art fuel management systems make the most of every micro-drop of fuel. Pick your engine, and enjoy the drive.

Technical data may be subject to change. Please talk to your Volvo dealer for the latest information.

EQUIP YOUR OWN VOLVO XC90. The impressive standard equipment level and reflect our core belief that functionality and beauty go everywhere together. For more information about the different equipment levels, please contact your Volvo dealer or visit www.volvocars.com.au

STANDARD

Active Bending Lights (ABL)
 Airbag, passenger side
 Aluminium roof rails
 Aluminium wheels 19"
 Audio controls in steering wheel
 Autodimm interior rear view mirror
 AUX input
 Bluetooth®
 Colour-coordinated wheel arches
 Cruise-control
 Cup holders, tunnel console
 Dynamic Stability and Traction Control (DSTC)
 Electronic Climate Control (ECC)
 Emergency Brake Assist (EBA)
 Floor mats
 Fog lights in front spoiler
 Height- and reach- adjustable steering wheel
 Illuminated vanity mirrors, driver and passenger

Inflatable Curtain (IC)
 Interior Air Quality System (IAQS)
 Leather-clad gear knob
 Leather-clad steering wheel
 Leather upholstery
 Load protection net
 Outside temperature gauge
 Power windows front and rear
 Premium Sound System
 Rear Park Assistance
 Rear Park Camera
 Remote control central locking
 Side Impact Protection System (SIPS)
 Speed Sensitive Power Steering
 Trip computer
 Volvo Navigation System (VNS)
 Watch-dial instrument cluster
 Whiplash Protection System (WHIPS)

COLOUR YOUR VOLVO. When it comes to the appearance of your Volvo, the choices of exterior colour, wheels and other styling items are probably your most important design decisions. For more exterior styling options and to build your new Volvo online, please visit www.volvocars.com.au

Clean colours

To reduce the use of environmentally hazardous solvents all Volvo exterior colours are water-based. What's more, our painting facilities are among the cleanest in the world.

Please note: It's not possible to reproduce exact original shades in printed matter. Please ask your dealer to show you samples.



614 Ice White
(also available for R-DESIGN)



426 Silver Metallic
(also available for R-DESIGN)



477 Electric Silver Metallic
(also available for R-DESIGN)



700 Twilight Bronze Metallic
(also available for R-DESIGN)



492 Savile Grey Metallic
(also available for R-DESIGN)



452 Black Sapphire Metallic
(also available for R-DESIGN)



612 Passion Red
(only available for R-DESIGN)



702 Flamenco Red Metallic



498 Caspian Blue Metallic
(also available for R-DESIGN)



487 Ember Black Metallic
(also available for R-DESIGN)



019 Black Stone
(also available for R-DESIGN)

EXTERIOR DESIGN. It's muscular without being aggressive. Purposeful lines hint at a truly versatile character, while its refined dynamic looks reveal a more sophisticated side. Rounded shapes interact with distinctively sculpted sections, creating a confident

Scandinavian style. Add to this a stance that leaves no doubt as to the intentions of this Volvo SUV. And to further emphasise the adventurous spirit of the Volvo XC90, there are a number of specially designed styling options.

Aluminium running boards and foot steps

Provide a more striking impression while matching the front and rear skid plates. What's more, they protect the door sills on uneven surfaces and make it easier to get in and out – and they're useful when loading the roof. Designed for a load of 300 kg. For extra convenience, foot steps can be added to the running board.

Side décor

Running along the bottom of the doors and wheel arches, the side décor gives the Volvo XC90 an even more exclusive appearance. It's painted in the same colour as the vehicle and features an integrated Metallic lower moulding.

Front bumper bar

Integrated in the front bumper to give the vehicle an even more powerful stance. Painted in Silverstone to match other exterior styling details. Alternatively, it can be painted in the same colour as the vehicle.

Aluminium crossbars

An aerodynamic design element that complements the roof rails and the design of your Volvo. These aluminium crossbars also allow you to exploit the roof's load-carrying capacity to the full.



EXTERIOR DESIGN Aluminium wheels



Galateia 8x19"
Silver Bright



Camulus 7x18"
Silver Bright



Situla 7x18"
Silver Bright

ACCESSORY Aluminium wheels



Thalassa 8x20"
Diamond Cut/Dark Grey matt
or Light Grey



Alastor 8x19"
Silver Bright



Oceanus 8x19"
Silver Bright



Nereus 7x18"
Polished



Nereus 7x18"
Silver Bright



The head of the class.

No matter its duration, any journey in a Volvo XC90 Executive will be memorable. Sophisticated yet tasteful styling on the inside is complimented by a unique design profile. From its 19" Galateia wheels to its door mirror capping, chrome-finished rear door pillars, front bumper bar and chrome-tipped tailpipes, this thoroughbred version of a thoroughbred SUV will always create the right impression.





Inside the specially designed Volvo XC90 Executive, you'll find seats upholstered in Executive Soft Leather with contrasting seams and piping – all the way back to the third row. The heated seats on the first and second row ensure a warm welcome. And as well as featuring the supreme comfort of perforated leather, the front seats are also equipped with ventilation and a massage facility. A luxury we're sure you'll appreciate during longer journeys.

Leather trimmed door panels with front padded armrests add to comfort while the hand-ground walnut wood trim and extra thick pile of the nubuck trimmed floor mats are the final word in understated luxury. And for that final exclusive touch? Why not add an integrated cooler box between the front seats?



Offblack interior, Executive Soft Leather perforated Soft Beige (CUSU)



Offblack interior, Executive Soft Leather perforated Chestnut (CU0P)



Offblack interior, Executive Soft Leather perforated Offblack (CU00)



Sandstone Beige interior, Executive Soft Leather perforated Soft Beige (CU10)



Wooden steering wheel, Offblack (Optional)



Wooden steering wheel, Sandstone Beige (Optional)



Gear knob with Walnut wood trim Geartronic (Standard)



Walnut wood trim in tunnel console and glove box (Standard)



The R-DESIGN variant of the multi-award-winning Volvo XC90 has it all: Compelling performance, distinctive styling and, of course, legendary Volvo safety. With its sports-tuned chassis, the Volvo XC90 R-DESIGN is not shy – especially not around corners. The exceptionally agile Volvo XC90 R-DESIGN secures its high-traction, road-holding ability courtesy of a unique, sports-tuned chassis, sports-calibrated steering and sophisticated stability-control technologies. The result is a vehicle that feels quicker and more responsive, yet remarkably composed and purposeful. This is preventive safety from Volvo that helps keep the thrill of driving (and much more) alive.

R-DESIGN seats

The leather R-DESIGN seats are covered in two premium grades of chrome-free hide with a contrasting colour inlay and embossed R-DESIGN logo. The front seats feature extra padding and beefier side bolsters to hug you in the corners.

Sports-tuned chassis

The Volvo XC90 R-DESIGN has a specially tuned chassis that separates this vehicle from the crowd. The front suspension uses McPherson struts with anti-dive and anti-lift functionality. The multi-link independent rear suspension is attached to a steel sub-frame. The front and rear both have firmer shocks and stiffer anti-roll bars for added stability and a quicker steering response.

Servotronic power steering

The R-DESIGN steering wheel with aluminium inlay doesn't just look smart. Behind it, the Servotronic power steering uses sophisticated, speed-sensitive technology to regulate the amount of power assistance a driver needs. At open road speeds, steering is firmer and more immediate. When parking or in slow traffic, steering is light and effortless. The Volvo XC90 R-DESIGN has a specially tuned Servotronic system that increases steering feedback significantly in the 50–60 km/h range.

High-performance wheels

The distinctive Vulcanis 19" wheels with five diamond cut spokes couldn't be more serious about driving. Behind them lie large, ventilated disc brakes, firmer shocks for improved body control and stiffer anti-roll bars to help keep the car flat through hard turns. If this isn't enough for you, Cratus 20" wheels are available as an option.

Sports tailpipes

Unique chrome-finish tailpipes ensure that the XC90 R-DESIGN sticks out from the crowd. Indeed, this feature alone could be what other drivers notice first as they follow your lead.

A selection of R-DESIGN items are also available as part of our Accessories range. Please contact your local dealer for further information.

SAFETY

At the core of every car we make, state-of-the-art technology helps support the driver and protect the occupants. And to further enhance the Volvo safety experience, there's a range of supplementary safety technology – for more performance and peace of mind.



SAFETY Preventive

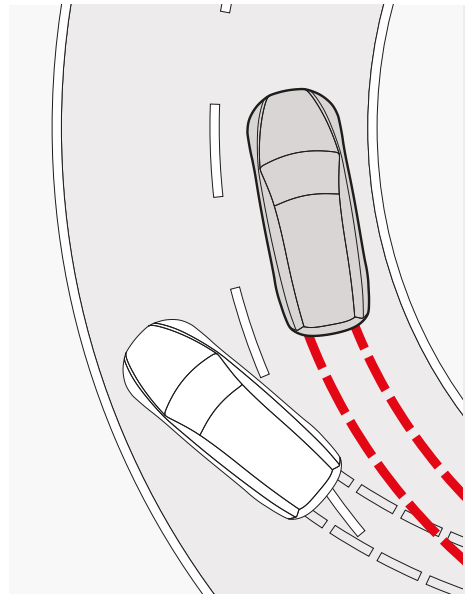

Dynamic Stability and Traction Control (DSTC)

By helping to prevent fishtails, spinouts and rollovers, stability-control technology like DSTC has been described as one of the most vital safety advances of the past decade. At the core of DSTC, a gyroscope senses the car's direction and compares it with steering wheel movements as well as the actual rotation of the car's wheels. DSTC is able to detect a potential skid and help counteract this by reducing the engine's power output or braking on one or more wheels.

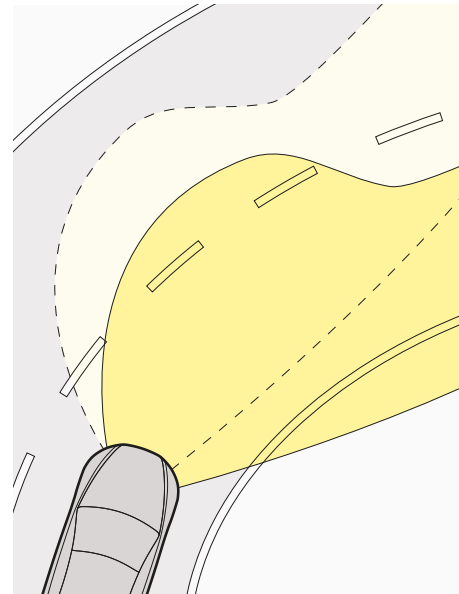

Active Bending Lights (ABL)

In addition to improving illumination by about 230% using Dual Xenon light technology, the Active Bending Lights give a 90% boost to your vision round bends at night. Controlled by micro-processors, the motorised lamps turn up to 15 degrees in either direction when driving – reliably lighting up your chosen path. A twilight sensor disengages the adaptive function during daylight.

Water-repellent front side windows

Giving far better visibility in the rain, these front side windows help repel water as you drive. The hydrophobic surface treatment turns water into small drops that are blown away by the force of the wind. This also gives you the benefit of less ice or frost in winter conditions.

Roll Stability Control (RSC)

In the event of an emergency manoeuvre, Volvo's Roll Stability Control (RSC) can step in to help prevent the vehicle from rolling over. It features a gyroscopic sensor that registers the vehicle's lean angle and rollover risk. If required, RSC will cut engine power or brake one or more of the wheels just enough to reduce the centrifugal force and help regain balance.

SAFETY Protective

Frontal structure

The generous front deformation zones are designed to yield in a controlled way to help absorb crash energy before it reaches the cabin. The transversely mounted and very compact engine enables optimal use of the deformation zones to help protect occupants. Longitudinal steel struts help disperse crash energy away from the front to the rear of the vehicle, further reducing the strain on the occupants.

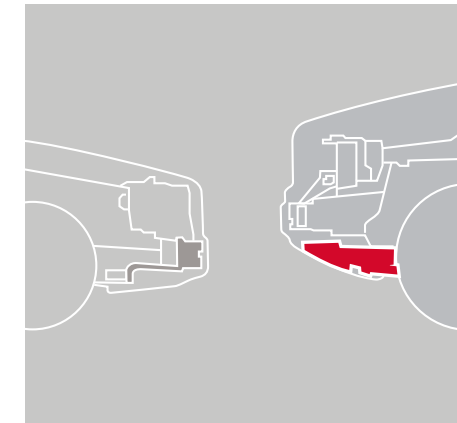

Lower cross member

To help protect the occupants in an oncoming car with lower positioned bumpers, a low cross member integrated in the front structure. In an impact, this cross member is designed to activate the other car's own crumple zones and other safety systems to help reduce the risk of injury.

Restraint technologies

In a collision, Volvo's restraint technologies interact to help reduce the impact. The **safety belts with pre-tensioners** activate within a few thousandths of a second in the event of a collision or rollover and tighten the belt to help keep the occupants securely restrained. The front seat safety belts then release a little so that the driver and passenger are cushioned by the airbags in a controlled manner. Helping to optimise protection, the **dual-stage airbags** adapt the level of inflation depending on the force of the collision. The driver's airbag also interacts with the deformation of the collapsible steering column. **Side airbags** in the front seats help reduce the risk of serious injuries in a side collision. In a collision or rollover, the **Inflatable Curtain (IC)** helps protect the heads of both front and rear outboard occupants. It also stays inflated for some seconds to provide prolonged protection for subsequent impacts.



Whiplash Protection System (WHIPS)

Integrated in the front seats, Volvo's WHIPS cradles the occupant to help reduce the risk of whiplash injury (one of the most common types of traffic injury and often the result of a low-speed rear impact collision). The function is activated by a collision of sufficient force from behind. Independent research has shown that WHIPS is one of the most effective systems in the world and can reduce the risk of long-term injuries by 50%.



In a Volvo, safety is about interaction. Because it's not the number of safety features that determines how safe a car is. It's how well they seamlessly interact to help keep the occupants out of harm's way.

In a rear impact the rear deformation zones will help to absorb crash energy. Even behind the third row there's a good deal of space to help provide effective protection. The fuel tank is designed to remain well protected in front of the rear axle. The head restraints help protect the neck and spine, and Volvo's unique Whiplash Protection System (WHIPS) cradles the front seat occupants in a controlled manner to help prevent whiplash injuries.

In a side impact Volvo's unique Side Impact Protection System (SIPS) helps distribute the crash forces across the car's body, away from the occupants. The side airbags in the front seats help protect the chest and hip, while the Inflatable Curtain (IC) adds head protection for all outboard occupants, including those in the third row.

In a rollover a gyroscope activates Volvo's Roll Over Protection System (ROPS). The safety belt pre-tensioners deploy to help keep occupants more securely restrained, and the Inflatable Curtain (IC) helps provide head protection. In addition, the safety cage is reinforced to help keep the passenger compartment intact.

In a frontal collision the generous deformation zones will yield to help absorb crash energy. The compact powertrain is designed to help optimise deformation. Inside the vehicle, safety belts interact with the collapsible steering column and dual-stage airbags to further help protect the occupants. A lower cross member helps protect occupants in an oncoming car with lower positioned bumpers. The front and bonnet are also designed to help reduce the risk of injury to unprotected road users.

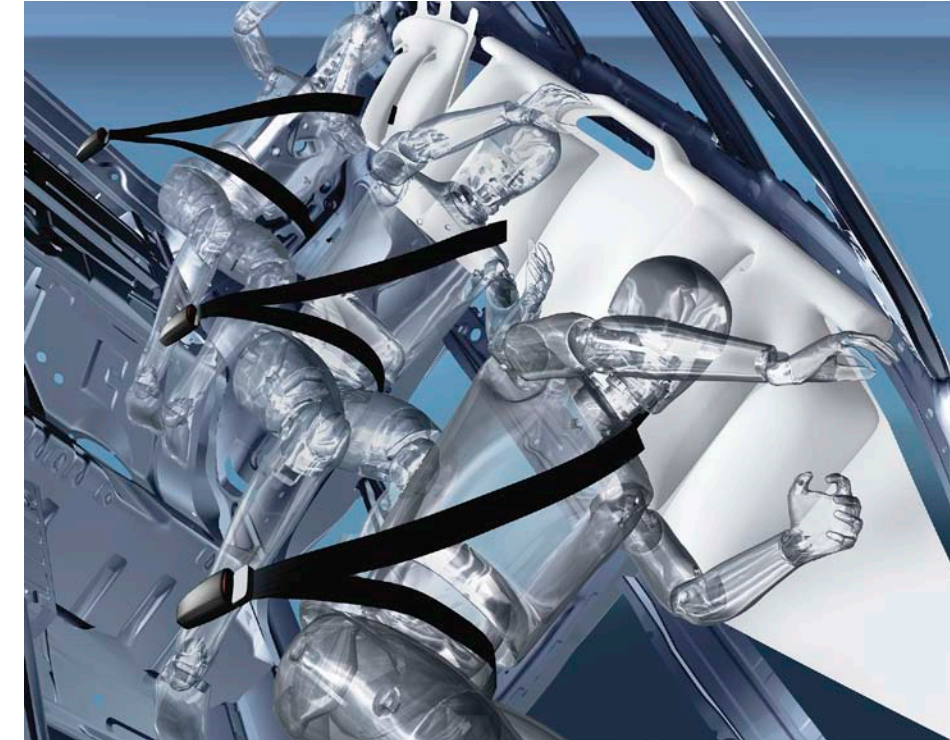

Roll Over Protection System (ROPS)

A robust roof structure together with Volvo's unique Roll Over Protection System (ROPS) help protect the occupants in a rollover situation. ROPS is activated by a gyroscope that monitors the vehicle's leaning angle. The safety belt pre-tensioners are activated at every seat to help keep occupants more securely restrained. At the same time, the Inflatable Curtain (IC) deploys and remains inflated for several seconds to provide extended protection. To help keep the passenger compartment intact despite severe external forces, door pillars and strategic parts of the safety cage are reinforced in ultra high-strength steel.

Protection of unprotected road users

To help reduce the risk of serious injuries to unprotected road users, the front of the vehicle is gently rounded, the headlamps are integrated flush with the body, and the bonnet is energy-absorbing to act as a crumple zone.

Side Impact Protection System (SIPS)

SIPS is a safety system unique to Volvo that has been developed to help protect the occupants, in the event of a side collision. The steel framework of the vehicle – including the front seats – is designed and reinforced to help displace the impact of a side collision away from the occupants to other parts of the car body and help prevent intrusion into the cabin. The side structure is extremely strong to help withstand a severe side impact. The Inflatable Curtain (IC) for all the outboard occupants including the ones in the third row, and the front seat side airbags interact to provide further protection.

SAFETY Child safety



Integrated booster cushion (15–36 kg)

The integrated booster cushion in the rear middle seat helps position a child (15–36 kg) in the correct position for the safety belt. It also offers a high level of comfort and visibility. The middle seat slides forward to bring a child closer to adults in the front. And for more legroom, simply lift out the rear section of the centre console. When not in use, the cushion is concealed in the middle rear seat.

Power child-safety lock

The power child lock enables you to conveniently lock the rear doors and rear power windows from the driver's seat and prevent them from being opened from the inside.

Approach and Home Safe Lighting

Activated with the remote control, Approach Lighting provides a warm reception on a dark night. It consists of interior and side lights – ground lighting too, if you choose it. Home Safe Lighting is activated with the headlight stalk as you leave the car and it provides a similar courtesy when exiting your car. This feature includes a dipped beam from the headlight to accompany you to your door.

SAFETY Security



Power retractable door mirrors with ground lighting

At the touch of a button, these door mirrors can be folded flat against the car where they are less likely to get damaged after you've parked. The integrated ground lighting is activated with the remote control. Besides enhancing security to and from your car at night, this is also convenient when getting in and out.

Laminated side door windows

Laminated side windows turn an attempted smash-and-grab into a time-consuming ordeal. They also enhance sound comfort in the cabin and contribute to UV protection. This option also includes water-repellent glass in the front side windows for improved visibility in wet weather.

COMFORT

A Volvo is always designed for more than one. Our technology aims to enhance the feel-good factor for everybody privileged to drive in a Volvo. And to further improve comfort and convenience, there's a range of clever equipment – customised for your Volvo and the people inside it.



COMFORT Seats



Seven individual seats

All occupants will appreciate the comfort of a separate, ergonomically designed seat. Cinema-style seating helps provide an excellent view, wherever you're seated. The easily adjustable front and second row seats make it easy to find the perfect seating position and maximum comfort. The middle seat also features an integrated booster cushion. In the third row of seats two passengers of up to 160 cm can ride comfortably. Each rear seat is easy to fold individually into the load area floor so you can transport both passengers and cargo without compromising on either comfort or safety.

COMFORT Seats



Fore-aft adjustable second row

Each seat in the second row can be moved forwards and backwards to offer you maximum comfort and versatility. While the outer seats can slide forward a full 100 mm, the middle seat features an integrated booster cushion and can slide forward nearly 300 mm so you can move a child closer to the adults in the front. And to provide added legroom for the passenger in the middle seat, simply remove the centre console's rear section.

Third row

Two passengers (up to approximately 160 cm tall) ride in comfort in the rearmost seats. Cup holders, a table and smart storage solutions make longer trips more enjoyable. To further enhance comfort, air conditioning with adjustable ventilation and heating vents can be fitted at the rear.



Power front seats

Find your perfect driving position with push-button ease. The driver's seat also incorporates a memory function that stores three separate seat and door mirror settings connected to a specific remote control – a feature that's appreciated when the car has several drivers. To facilitate parking, the door mirror on the passenger side tilts automatically when reversing.

COMFORT Climate

Electronic Climate Control (ECC)

ECC ensures you and your passengers always enjoy a pleasant in-car climate. It maintains the set temperature inside the car, however much the temperature outside changes or the sun shines in. The driver and front-seat passenger can set the temperature individually for each side.

Interior Air Quality System (IAQS)

Volvo's IAQS continuously monitors incoming air and will, if necessary, temporarily close external air vents to shut out carbon monoxide, ground-level ozone and nitrogen dioxide. Meanwhile, an active carbon filter protects the occupants from other harmful gases and unpleasant odours. This helps ensure that the air you breathe in the car is cleaner than the air outside when driving in heavy city traffic and tunnels.



Power glass sunroof

This makes the interior feel extra light and airy. It opens and closes at the touch of a button. If the sun is too strong, just close the built-in sunshade.

COMFORT Climate



Third row AC

Supplementing Electronic Climate Control, this manual air-conditioning system boosts comfort in the third row. Passengers can conveniently adjust the fan speed themselves and regulate the air flow via separate vents.

COMFORT Storage

Cup holders, rear

Retractable cup holders are easily accessed in the rear of the tunnel console, and bottles can be conveniently stored in the door panels.



Front centre armrest and cup holders

The centre armrest conceals a host of conveniences. Fold back the upper section to reveal a handy storage space for CDs, sunglasses and other small items. It also provides rear-seat passengers with a convenient table. Double cup holders in the front of the armrest ensure that refreshments are always easy to reach. These cup holders can be concealed when not in use. Here you'll also find an AUX input and – depending on your choice of audio system – a USB port to connect your MP3 player to the vehicle's audio system.

TECH & SOUND

Employing the latest information technology, your Volvo is prepared to support and entertain you at a very high level. Surround yourself and your friends with world-class sound and enjoy the innovations that help ensure your command of the road and the pleasure of travelling.



TECH & SOUND Driver's support



Automatically dimmed inner rear-view mirror

This is a mirror that automatically adjusts to deflect the headlamp beams of the car behind you. When there's no light to dazzle you, it automatically readjusts to its normal setting. It can be supplemented with an integrated compass.

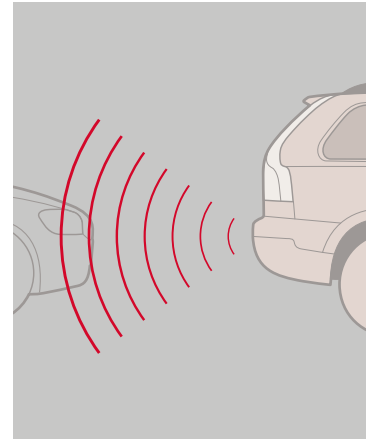

Park assist rear

► Park assist front

Activated when you engage reverse gear, rear park assist helps you when reversing into tight spaces. The audio system is turned down and a pulsating sound from the rear loudspeakers becomes a continuous tone as you approach an obstacle. Front park assist performs a similar function at the front of the vehicle – alerting you via the front loudspeakers.



Park Assist Camera

If the car is equipped with VNS navigation and park assist camera, this helps display what's going on behind your car when reversing. The system uses the VNS screen and a camera discretely located over the numberplate. On-screen guiding lines provide extra assistance for smooth parking.

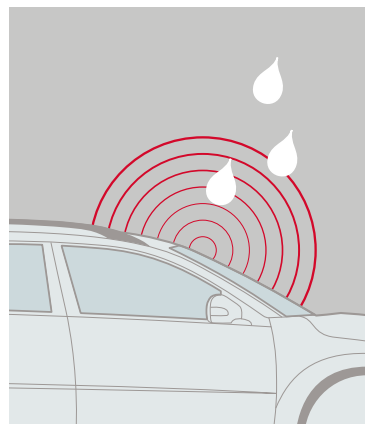

Rain sensor

Once activated, the rain sensor can start the windscreen wipers as soon as it begins to rain or if water splashes onto the windscreen. For your convenience, it can also automatically adapt the intermittent windscreen wiper function. Its sensitivity can be adjusted via a ring on the wiper stalk.

TECH & SOUND Communication



Integrated Bluetooth® handsfree system

Bluetooth® technology enables a mobile phone to be connected wirelessly to the infotainment system in your Volvo. Once configured for a mobile phone, the system automatically recognises your phone as you enter the car. And as you climb in and out of the car, the system automatically allows you to switch freely from the phone to the handsfree system and back again. With Volvo's integrated Bluetooth® handsfree system you conveniently operate your phone using the buttons on the steering wheel or the centre console keypad.

The Bluetooth word mark and logos are owned by the Bluetooth SIG, Inc. and any use of such marks by Volvo Car Corporation is under license. Other trademarks and trade names are those of their respective owners.



Volvo Navigation System (VNS)

Volvo's GPS-based VNS navigation system offers both voice guidance and graphic navigation all the way to your destination. Extremely swift and precise, this new generation VNS features a hard disk drive covering maps for major parts of Australia and New Zealand. The system is fully integrated in your Volvo and is easily controlled from the steering wheel or optional remote, and the screen is positioned so you can keep your attention on the traffic. You can choose between two operating modes – Easy and Advanced. When VNS is not needed, the screen is hidden in the dash.

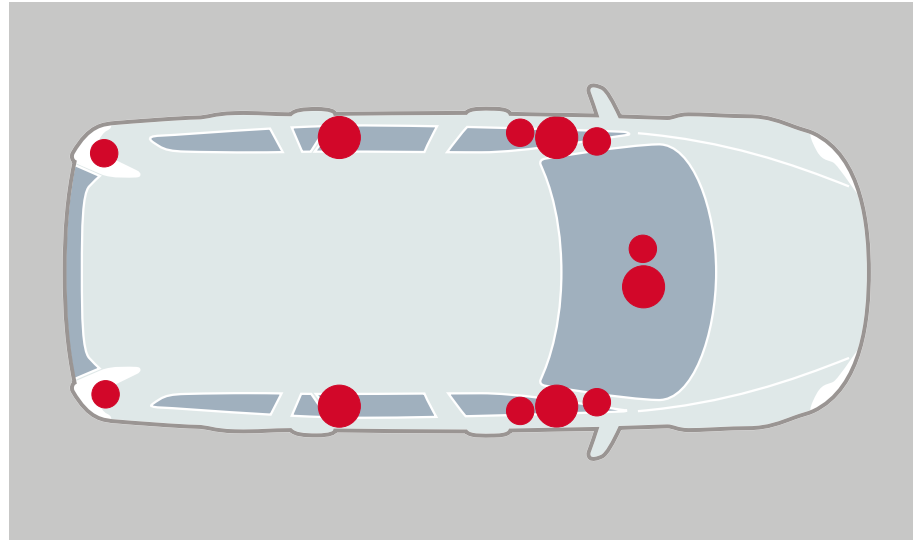

Premium Sound loudspeakers

The twelve high-end loudspeakers in the Premium Sound system are powered by a 5x130 W digital amplifier. There are three separate drivers – woofer, midrange and tweeter – in each front door, a coaxial woofer/tweeter in each rear door and a tweeter in each rear pillar. Each speaker has a crossover filter to maximise fidelity. The latest generation Dolby® surround system with a centre loudspeaker and sound processor recreates authentic sound with a strong sense of presence for everyone in the vehicle – a Volvo world first. The digital class D amplifier features new technology that provides extremely high efficiency, enabling it to generate maximum audio power from the least amount of current.

Premium Sound audio system

The Premium Sound system is in a class of its own. The digital class D amplifier generates 5x130 watts of music. Dolby® Pro Logic® II surround sound recreates a sound that's equally authentic at each seating position. There are 12 high-end loudspeakers specially developed for the Volvo XC90 and a true concert hall experience. The Premium Sound system includes:

- RDS radio
- MP3 and WMA compatible CD player
- USB and AUX input
- 5x130 W digital class D amplifier
- Dolby® Pro Logic® II surround sound with centre loudspeaker and digital sound processor
- 12 high-end loudspeakers

Options: steering wheel integrated controls, separate remote control and rear headphone connectors. A 6-CD changer is available (replaces the CD player) – this option deletes the USB input, but a USB and iPod® Music Interface (accessory) can be added.

Dolby, Pro Logic, and the double-D symbol are registered trademarks of Dolby Laboratories.



Rear headphone connectors

Allow four rear-seat passengers to listen to the radio or their favourite CD at the same time, without disturbing other occupants. With separate controls for headphone volume and audio source. Also features controls for changing tracks or switching radio stations.



MP3 compatibility

There are a number of ways in which to enjoy MP3 music files in your Volvo XC90. If you'd like to connect your personal MP3 player to the audio system, there's a standard USB and AUX input between the front seats. Volume is conveniently controlled from the steering wheel, centre console and rear headphone connectors. The USB input* also allows you to fully integrate your iPod®, MP3 player or USB device with the audio system. Playlists, songs and artists are clearly displayed in the centre console, while your player will be charged at the same time. The audio systems also feature an MP3 and WMA compatible CD player.

*Not in combination with a 6-CD changer. Choosing a 6-CD changer, you can add a USB and iPod® Music Interface to connect your MP3 player to the audio system.

Audio streaming

The integrated Bluetooth® technology allows wireless communication and streaming of music files. Simply connect your Bluetooth® compatible mobile phone to your audio system and enjoy the music files stored in your phone.



► Rear Seat Entertainment (RSE) dual screen

With Volvo's new generation DVD-based RSE dual screen, the rear seat passengers can enjoy a film or play a game – together or separately. Two 8-inch widescreen displays are integrated in the front-seat head restraints and provide excellent image quality. Wireless headphones keep things calm in the cabin and you can listen to the music or programme of your choice. Via an AUX input, you can also connect external devices such as an iPod®, MP3 player, extra DVD player or a digital camera. The RSE system is an integrated part of the car. It matches the interior perfectly and is available with all types of upholstery.

Volvo XC90

ACCESSORIES



EXTERIOR STYLING:

Running Boards. Enhance the car's powerful appearance and Cross Country feel. With an attractive design in aluminium with fully cast end sections, the whole car takes on a more powerful appearance. Contains a practical footstep which is fitted to the top of the Running Board.

20" THALASSA Wheels.

MAKE YOUR OWN LEGEND.

Large on life and big on ability, the Volvo XC90 is one of the planet's most awarded luxury SUVs. Internationally recognised for outstanding design, safety and environmental care, this highly refined icon of excellence awaits your command. Like this vehicle with few limits, your customising possibilities are numerous. Consider the exterior styling package to dial up the bold, athletic stance of this all-road champion. Dress the four corners with 20" Thalassa aluminium wheels and mud flaps. Expand your superior view to include what's directly behind you with the rear park assist camera.



CARGO COMPARTMENT MAT, PLASTIC:

A practical load compartment mat in moulded plastic for those who live an active and outdoor life. The mat is coated with a layer of friction-increasing material to prevent the load from sliding around. It has raised edges that effectively prevent dirt and water from leaking into the load compartment.



CARGO COMPARTMENT SEPERATOR, LONGITUDE:

A steel load compartment divider enables you to separate the load compartment longitudinally, and have two load compartments in one. Enables you to separate dirty or fragile cargo from other cargo.



DIRT COVER, FULLY COVERING:

A practical protector for the cargo compartment that covers the floor and side walls of the cargo compartment, plus the rear of the rear seats. Made from durable, dirt-resistant vinyl.



LOAD CARRIER:

A specially designed transport system for loads on the roof. The load carriers are two swept aluminium profiles and feet with fully covering black plastic covers.



LOAD NET, CARGO COMPARTMENT:

A practical fabric net that prevents cargo from sliding around in the cargo compartment. Made of an elastic material, making it easy to load cargo under the net.



REAR SEAT ENTERTAINMENT (RSE):

RSE is the ultimate entertainment system for passengers in the rear seat. The RSE consists of: a DVD-player easily accessible in the centre console between the front seats, two independent 8" widescreen monitors mounted in the front head restraints, a remote control and two sets of independent, wireless IR headphones. The system's AUX input makes it possible to connect extra equipment, such as game consoles, iPod®, MP3 player, video cameras, laptops or even another portable DVD player.



MUDFLAPS:

A mudflap that blends in well with the car's design and effectively protects it's sides from road splashes. The splash guard is made of a plastic material that gives without cracking in case of an impact.



POD BOX:

To meet your various load needs, there's a range of aerodynamic Volvo roof boxes – from 320 litres up to 520 litres – comprising the most advanced function and design.



TOWBAR-MOUNTED BICYCLE HOLDER:

A very practical and stable bicycle holder with a new and exclusive design that is easy to handle and store.



DETACHABLE TOWBAR:

Designed specifically for your Volvo, the locally sourced towbar meets Australian standards and requirements. Easy to remove and fit when required.



PORTABLE NAVIGATION GARMIN:

The Garmin nüvi® is sleek and stylish, yet loaded with really smart navigation features and convenient functions. Enjoy the bright multi-touch display, the voice-activated navigation, 3D views, lane assist and many other great features. With the Garmin nüvi, you get an easy-to-use, intelligent portable navigation of award-winning design. The Garmin nüvi comes preloaded with full-coverage Australian and New Zealand mapping and it's the perfect choice for you who want to make the most of your Volvo driving experience. nüvi is a trademark of Garmin Ltd.

TECHNICAL SPECIFICATIONS

XC90	3.2		D5	
	R-DESIGN	EXECUTIVE	R-DESIGN	EXECUTIVE
DRIVEAWAY PRICING*				
Please contact your local Volvo dealer for driveaway pricing, or call 1800 7 VOLVO for referral to your nearest Volvo dealer.				
ENGINE / PERFORMANCE				
Engine	Six-cylinder, 24 valve DOHC petrol engine.		Five-cylinder, 20 valve DOHC turbocharged diesel engine.	
Location	Front Transverse		Front Transverse	
Drive	All-Wheel Drive		All-Wheel Drive	
Displacement	3192cc		2400cc	
Power output	179kW at 6400rpm		147kW at 3900rpm	
Torque	320Nm at 3200rpm		420Nm at 1900 - 2800rpm	
Acceleration 0 -100km/h	9.5 seconds		10.3 seconds	
Top Speed	210 km/h		205 km/h	
Fuel Economy (Combined) l/100km	11.5		8.8	
CO2 (Combined) g/km	269		233	
TRANSMISSION				
Automatic	6 speed Adaptive Geartronic			
STEERING				
System	Electro-Hydraulic			
Turns to lock	2.5			
Turning circle (metres)	13.1			
Speed sensitive power steering	•			
CHASSIS				
	Coilover strut front suspension			
	Anti-dive anti-lift function			
	Multi-link independent rear suspension			
	Anti-roll bars front and rear			
Comfort Chassis	—	•	—	•
Sports Chassis	•	—	•	—
Nivomat, self levelling suspension	•	•	•	•
WEIGHT				
Auto	2184kg		2125kg	
FUEL TANK				
Capacity	80 litres		68 litres	
LOAD CAPACITY				
Maximum trailer weight (braked)	2250kg		2250kg	

XC90	3.2		D5	
	R-DESIGN	EXECUTIVE	R-DESIGN	EXECUTIVE
AUDIO AND COMMUNICATION				
Premium Sound, AM/FM radio, 12 speakers, Dolby® Pro Logic® II Surround system with USB iPod connectivity			•	
Single CD player			•	
Audio controls in steering wheel			•	
Auxiliary audio input			•	
Bluetooth with Audio streaming			•	
Volvo Navigation System (VNS)			•	
Rear headphone sockets			\$275	
Rear Seat Entertainment (RSE)			\$4,175	
6 Disc in-dash CD player (replaces iPod connectivity)			\$850	
INTERIOR EQUIPMENT				
Rear park camera			•	
Rain sensor			•	
Water repellent glass, side windows			•	
Sunroof, glass, electrically operated			\$2,650	
Park assist, rear			•	
Automatically dimmed inner rearview mirror			•	
Compass in Automatically dimmed inner rearview mirror			\$100	
Grocery bag holder			\$200	
Windows, electrically operated up and down, front and rear			•	
Cruise control and Trip computer			•	
Luggage net, backrest			•	
Load cover, soft			•	
Cup holders, front tunnel console			•	
Power plugs, 12V tunnel console, cargo area and rear seat			•	
Watch-dial instrumentation			•	
Refrigerator	—	\$1,450	—	\$1,450
SEATING				
Front seat electrically adjustable with memory, driver	•	•	•	•
Front seat electrically adjustable, passenger	•	•	•	•
Front seats, heated	\$325	•	\$325	•
Front seats, heated, ventilated and massage	—	•	—	•
Rear seats, heated	—	•	—	•
Adjustable lumbar support, driver and passenger	•	•	•	•
Second row backrests individually folding, 40/20/40	•	•	•	•

XC90	3.2		D5	
	R-DESIGN	EXECUTIVE	R-DESIGN	EXECUTIVE
INTERIOR TRIM				
Executive:				
Sovereign Hide upholstery	—	•	—	•
Executive Walnut Inlays (door handles, centre console)	—	•	—	•
Aluminium Inlays (door handles, centre console)	—	▲	—	▲
Executive Wood steering wheel and gear knob	—	•	—	•
Executive floor mats	—	•	—	•
R-Design:				
R-Design Leather (interior / seats)	•	—	•	—
R-Design Inlays (door handles, centre console)	•	—	•	—
R-Design sports leather steering wheel and gear knob	•	—	•	—
R-Design floor mats	•	—	•	—
EXTERIOR				
Roof rails, silver			•	
Metallic paint			\$1,550	
R-Design grill, scuffplate, dual exhaust	•	—	•	—
LIGHTING				
Courtesy illumination front and rear with delay			•	
Home Safe and Approach Lighting systems			•	
Foglights front and rear			•	
Illuminated vanity mirror, driver and passenger			•	
Electrically retractable door mirrors, with puddle lights, heated			•	
Active Bending Lights (ABL)			•	
Headlight wash system			•	
SECURITY				
Central locking, Remote-controlled including Fuel filler			•	
Door locks and revolving cylinders			•	
Power child lock			•	
Electronic immobiliser			•	
Shiftlock and key lock automatic transmission			•	
Laminated side windows			\$525	
Volvo Guard Alarm			\$850	
Mass movement sensor, includes Alarm			\$1,100	
Inclination sensor, includes Alarm			\$975	

XC90	3.2		D5	
	R-DESIGN	EXECUTIVE	R-DESIGN	EXECUTIVE
CLIMATE				
Electronic Climate Control			•	
Third row air conditioning			\$800	
Interior Air Quality System with sensor (IAQS)			•	
Integrated booster cushion			•	
Rear seat backrests individually folding			•	
Tinted windows, rear side doors and cargo area			\$850	
IR protected windscreen and front door windows			\$625	
SAFETY				
Anti-lock Brake System (ABS)			•	
Electronic Brake Distribution (EBD)			•	
Emergency Brake Assist (EBA)			•	
Airbag, driver and passenger, dual stage			•	
Three point front safety belts, automatic height adjustment and belt tensioner			•	
Inflatable Curtain (IC)			•	
Side impact Protection System (SIPS)			•	
Dynamic Stability and Traction Control (DSTC)			•	
Roll Stability Control (RSC)			•	
Head restraints and anti-submarining on all seats			•	
Whiplash Protection System (WHIPS)			•	
First aid kit			\$100	
Blind Spot Information System (BLIS)			\$1,275	
Warning triangle			•	
ALLOY WHEELS AND TYRES				
7.0 x 17" NEPTUNE Silver Stone	—	▲	—	▲
7.0 x 18" CAMULUS Silver Bright	—	▲	—	▲
7.0 x 18" SITULA Silver Bright	—	▲	—	▲
8.0 x 19" VULCANIS Diamond Cut	•	—	•	—
8.0 x 19" VULCANIS Silver Bright	▲	—	▲	—
8.0 x 19" GALATEIA	—	•	—	•
8.0 x 20" CRATUS	\$1,600	—	\$1,600	—
Lockable wheel bolts	\$150	\$150	\$150	\$150
Tempa spare	—	•	—	•
Tyre repair kit with Jack	•	—	•	—

* Vehicles must be purchased from an authorised Volvo dealer. Information is correct at time of printing, however the manufacturer reserves the right to make changes without notice. Please confirm current specification and pricing details with your Volvo dealer. Option pricing displayed is GST inclusive. Accessories and / or options fitted to vehicles may affect vehicle performance, fuel consumption and vehicle emissions.

• Standard ▲ No cost option — Not available

Printed August 2011 / MY12 (1)

Care by Volvo.

Make the most of your Volvo experience.

It's built into your Volvo – the care for you and your loved ones. And it's also there for you during all the time you own it. Care by Volvo is a family of services to help you make the most of your Volvo experience. These services reflect a set of values shared by the entire Volvo organisation, values that make your satisfaction and safety a top priority. Whatever your needs during your Volvo ownership, there is a smooth and considerate solution.

Volvo Car Insurance.

As with our cars, we want to ensure our Volvo Car Insurance lives up to the expectations of Volvo owners in every way. It is what you would expect from Volvo.

Benefits include:

- New car replacement*
- Genuine Volvo Parts*
- Choice of Repairer
- Maximum No Claim Bonus protected
- Rental car following theft
- Attached Trailer and Caravan Cover
- Cover for authorised Volvo loaned service vehicles

Options available:

- Removal of excess for windscreen claims;
- Rental or loan car following an accident;
- Agreed Value;

*Subject to availability

This is a summary of the benefits available under Volvo Car Insurance. We do not advise you whether the insurance is appropriate for your personal objectives, financial situation or needs. To decide if it is appropriate for you, ask for a copy of the Policy Document and Product Disclosure Statement listing the full benefits and limits to cover. Please see your Volvo Dealer for a quotation.

This insurance is issued by Allianz Australia Insurance Limited AFS Licence No. 234708, ABN 15 000 122 850 (Allianz). In arranging this insurance Marsh Pty Ltd, AFS Licence No. 238983, ABN 86 004 651 512 and authorised dealers act as agents of Allianz and not as your agent.

Volvo Car Financial services.

Choosing the right vehicle and finding the right financial package has been made easier with Volvo Car Financial services. As you would expect, we have a flexible range of financial products, tailored to make your life easier.

Whether you're a private purchaser or you're choosing a Volvo for business, we have a wide range of flexible finance and lease products. After all, the right car needs the right financial package to complement your lifestyle.

Please contact your local Volvo dealer for more information on the individual finance products available, you can find your local dealer at: www.volvocars.com.au

Important Notice:

1. Volvo Car Financial Services is a registered business name of Macquarie Leasing Pty Limited ABN 38 002 674 982 (ML) who is the financier of these products. ML is not an authorised deposit-taking institution for the purposes of the Banking Act 1959 (Cth), and ML's obligations do not represent deposits or other liabilities of Macquarie Bank Limited ABN 46 008 583 542. Macquarie Bank Limited does not guarantee or otherwise provide assurance in respect of the obligations of ML.

Volvo New Car Warranty.

Every new Volvo is covered by our comprehensive three-year warranty giving you peace of mind for a full three years and unlimited kilometers. Please contact your local Volvo dealer for full new car warranty terms and conditions.

Volvo Extended Warranty.

Volvo Car Extended Warranty is designed for additional peace of mind. Volvo Car Australia offers an additional 12 or 24 month's extended warranty after the expiry of the original 3 year new car warranty (must be purchased within new car warranty period).

Please contact your local Volvo dealer for full Extended Warranty terms and conditions.

Volvo Roadside Assistance.

Volvo Roadside Assistance is not just there to get you going again if your car breaks down. It's also there for more human mistakes like running out of fuel or locking your keys inside the car. In the unlikely event that your Volvo encounters a mechanical breakdown, you can benefit as a Volvo owner from our complementary Volvo Roadside Assistance Program, which gives you total peace of mind 24 hours a day, every day, Australia-wide.

The Volvo Roadside Assistance program is valid for the length of the manufacturer warranty or Extended Volvo Roadside Assistance Program.

VOLVO SERVICE 2.0*

FREE SOFTWARE UPDATES ARE JUST THE BEGINNING

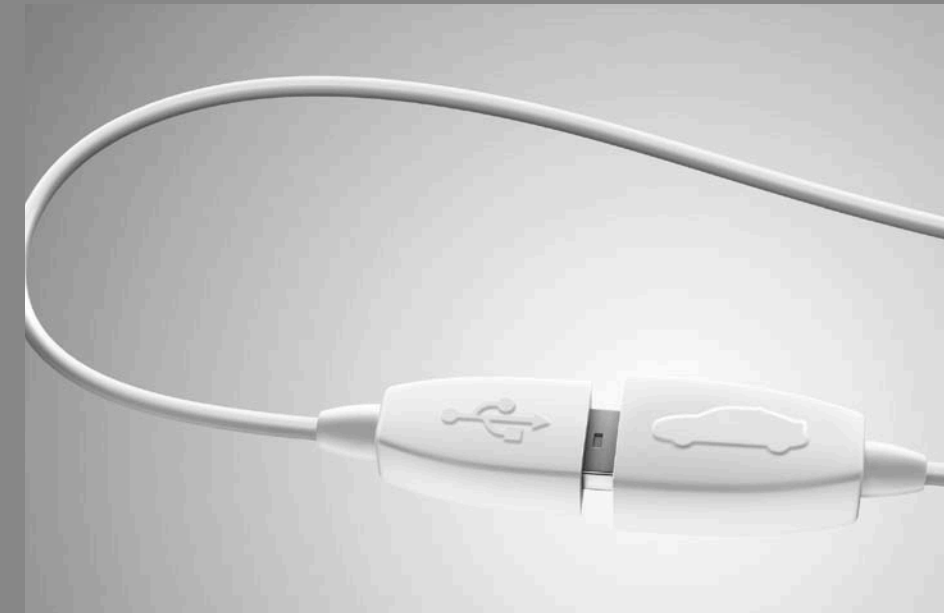

In today's cars there are many computers and just like with desktop computers, their software should be updated from time to time.

So, in the interest of providing the best service possible, we've developed Volvo Service 2.0, where your Volvo software is updated free of charge as part of a routine Volvo scheduled service. This means that your Volvo systems (which are unique to your vehicle) will always be optimised for top performance.

Free software updates are just the tip of the iceberg. Volvo Service 2.0 ensures you'll always have your vehicle serviced by a Volvo-certified technician, using Volvo methods and Volvo Genuine parts.

You'll be offered 12 months free roadside assistance and a complimentary exterior wash. In fact, we'll even provide you access to an alternative transport solution while your vehicle is being serviced.

For more information on the many benefits of Volvo Service 2.0, just call us on **1800 786 586**, go to <http://www.volvocars.com.au> or visit your nearest Volvo dealer.



VOLVO SERVICE 2.0* ALSO INCLUDES:

VOLVO ASSISTANCE:

For peace of mind, every Volvo service comes with a complimentary roadside assistance package, covering you for 12 whole months.



ALTERNATIVE TRANSPORT:

It's not easy being without a car, that's why Volvo Service 2.0 offers you alternative transport solutions while your vehicle is being serviced.



CONDITION CHECK:

We will perform a health check of your Volvo and provide you with a check list, with a focus on safety features, while we are servicing your Volvo.

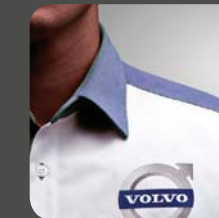

VOLVO-CERTIFIED TECHNICIAN:

Using only technicians trained by Volvo, to work on Volvo cars, a Volvo Service 2.0 service ensures your Volvo is placed in the most qualified hands.



CAR WASH:

After we've finished fine tuning your car on the inside, Volvo Service 2.0 will fine tune it on the outside thanks to a complimentary exterior car wash.



DEALER FOLLOW-UP:

With Volvo Service 2.0, your service doesn't end when you drive out of the centre. We'll also call you a couple of days afterwards to check things are still running smoothly.

PERFORMANCE Chassis

Chassis

The Volvo XC90's all-road capability is based on generous ground clearance (218 mm), a comparatively low centre of gravity and an advanced chassis. The rigid body enables optimal suspension performance, balanced handling and a high level of comfort. Front and rear suspension interact to provide stable braking and smooth steering. In a curve, the rear wheels have a slight steering facility for added stability and steering response. The Volvo XC90 R-DESIGN has a specially tuned sports chassis – the front and rear suspensions both have firmer shocks and stiffer anti-roll bars for added stability and a quicker steering response.

Six-speed Geartronic automatic transmission

For the best of two worlds, there's the six-speed Geartronic – a responsive automatic that's ideal for relaxed driving, tough conditions or towing. This also allows manual gear shifting so you can maintain a lower gear to bring up the revs or for the added assistance of engine braking. A special winter setting makes it easier to move off and maintain a grip on slippery surfaces.

PERFORMANCE Engines

3.2 AWD, six-cylinder petrol (179 kW)

This highly compact in-line six-cylinder petrol engine meets high expectations of performance, comfort and environmental care. The smooth running and responsive engine character provides a relaxed drive at all speeds. Advanced engine technology, such as the variable geometry intake system, helps increase torque over a wide speed range and ensures power at high revs. Depending on your driving style and the situation, the intake valve train automatically switches between economy and performance modes to optimise efficiency. The engine's compact design aids safety performance in a frontal collision. The latest generation of fast-response emission-control technology ensures that the engine complies with stringent environmental standards such as Euro 5.

	3.2 AWD	D5 AWD
Engine type:	3.2-litre six-cylinder petrol engine	2.4-litre five-cylinder direct injection common-rail turbodiesel
Transmission:	Six-speed Geartronic	Six-speed Geartronic
Fuel consumption, litres/100 km, mixed cycle auto:	11.5	8.8
CO ₂ g/km, auto:	269	233
Max. power output, kW at rpm:	179 at 6400	147 at 3900
Max. torque, Nm at rpm:	320/3200	420/1900–2800
Acceleration, 0–100 km/h in sec auto:	9.5	10.3
Top speed km/h auto:	210	205
Fuel tank, litres:	80	68
Environmental classification:	Euro 5 (2011)	Euro 5 (2011)

All technical data may be subject to change. Please talk to your Volvo dealer for the latest information.

Speed-dependent steering

The optional speed-dependent and progressive power steering provides progressively less servo assistance the faster you drive. Higher steering precision and enhanced road feedback are easily enjoyed benefits. At lower speeds, added power assistance makes the car even easier to manoeuvre, for instance when parking. The Volvo XC90 R-DESIGN has specially tuned speed-dependent steering that further increases road feedback for a sportier driving experience.

All-wheel drive with Instant Traction™

Volvo's pre-charged, electronically controlled all-wheel drive technology – AWD with Instant Traction™ – means greater agility. Constant hydraulic pressure ensures that power is promptly distributed to the wheels with the best traction. Wheel spin is minimised to provide immediate acceleration and reassuring stability in slippery conditions. When cruising on straight and dry roads, front wheels receive up to 95% of the power for optimum stability and fuel economy. However, during quick acceleration or in a sharp bend, up to 50% of the power instantly goes to the rear wheels – depending on what's needed to achieve maximum stability and grip. The immediate response of the AWD system allows understeering and oversteering tendencies to be compensated for with exceptional precision, giving a feeling of total control and driving pleasure.

D5 AWD, five-cylinder turbodiesel (147 kW)

Dynamically matched to the Volvo XC90, the efficient all-aluminium D5 turbodiesel is a harmonious source of power. Advanced diesel technology, such as common-rail direct injection and variable turbine geometry ensure a quick and comfortable response, superior fuel economy and cleaner exhaust. Its high torque (max 420 Nm) provides remarkable flexibility in any situation. Low weight further enhances fuel economy and a balanced drive.

7-seater

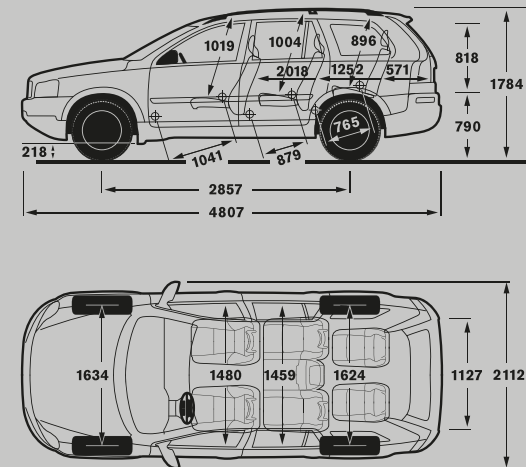

MEET THE FAMILY.



Volvo C30 The compact and charismatic SportsCoupe.



Volvo C70 A retractable hardtop convertible that seats four adults with comfort.



Volvo S40 The compact and energetic saloon.



The all-new Volvo S60 The sleek and sporty saloon, created to thrill.



Volvo S80 The premier saloon, meticulously engineered for superior driving comfort.



Volvo V50 The Sportswagon – flexible, compact and full of zest.



The all-new Volvo V60 The dynamic Sportswagon, created to inspire, designed for an active life.



Volvo V70 The genuine family estate – highly competitive yet comfortably versatile.



Volvo XC60 A sporty coupe and a capable all-roader fused into a Swedish crossover experience.



Volvo XC70 The rugged yet stylish all-roader.



Volvo XC90 The versatile SUV that takes you anywhere with grace.

Discover Volvo accessories and more detailed information for each car. Visit www.volvocars.com.au

For further information, please contact your Volvo Dealer or Volvo Car Australia on 1800 7 VOLVO or visit www.volvocars.com.au*
*NZ customers please contact your Volvo Dealer or visit www.volvocars.co.nz



DESIGN THE VOLVO THAT'S REALLY YOU. EXPERIENCE IT INSIDE AND OUT IN 360 DEGREES IN AMAZING 3D. LEARN ABOUT THE DETAILS, TECHNICAL FEATURES AND ACCESSORIES. SEE FILMS ABOUT YOUR FAVOURITE VOLVO AND ITS INNOVATIONS. COMPARE DIFFERENT VOLVO MODELS AND ENGINE ALTERNATIVES. DOWNLOAD IMAGES AND BROCHURES. JOIN THE VOLVO COMMUNITY AND SHARE GREAT CAR STORIES FROM ALL OVER THE WORLD. FIND YOURSELF AT WWW.VOLVOCARS.COM.AU

VOLVO

Volvo Car Australia

August 2011.

Please note: Some of the information in this brochure may be incorrect due to changes in product specifications that may have occurred since printing. Some of the equipment described or shown may now only be available at extra cost. Before ordering, please ask your Volvo dealer for the latest information. The manufacturer reserves the right to make changes at any time and without notice to prices, colours, materials, specifications and models.