



This Service Information bulletin supersedes SI B11 08 03 **dated February 2009**.

NEW designates changes to this revision

SUBJECT

Oil Separator – Cold Climate Conditions

MODEL

E39 (5 Series) **NEW** all with M54 engine

E46 (3 Series) **NEW** all with M54 engine

E53 (X5) **NEW** all with M54 engine

E60 (5 Series) **NEW** all with M54 engine

E83 (X3) **NEW** all with M54 engine

E85 (Z4) **NEW** all with M54 engine

SITUATION

Certain areas of the US experience extremely cold climate conditions during the winter months. A small number of vehicles in the above-listed Series have experienced problems ranging from leaking or broken valve covers to complete engine failure.

CAUSE

Moisture accumulating in the engine oil separator; hose to oil dipstick guide tube; or the orifice in the dipstick guide tube can freeze. When this occurs, depending on the position of the internal valve, it may either cause high crankcase pressures (stuck closed) resulting in valve cover leakage and/or breakage, or cause an oil hydro-lock condition (stuck open), which could result in engine damage.

CORRECTION

Replace the crankcase vent valve, crankcase vent hoses, and dipstick guide tube.

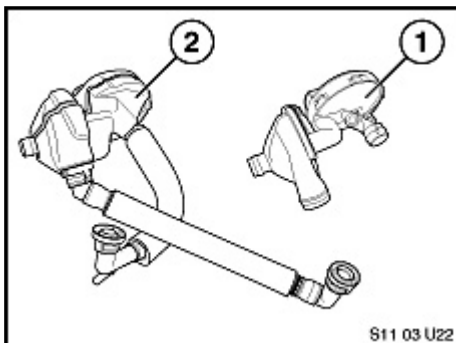

1. Replace the oil separator and hoses (1) with the new insulated style (2).

2. If the vehicle is already equipped with the new insulated crankcase ventilation valve and hose, only replace the dipstick guide tube with the part number from the list by model below.
3. If the vehicle is not equipped with the new insulated crankcase ventilation valve and hose, replace those parts with the updated style and replace the dipstick guide tube with the part number from the list by model below.

PARTS INFORMATION

E39 (5 Series)

Part Number	Description	Quantity
11 61 7 534 237	Oil Separator Repair kit	1
11 43 7 565 437	Dip Stick Guide Tube	1
11 15 7 532 629	Hose	1

E46 (3 Series) rear-wheel drive only

Part Number	Description	Quantity
11 61 7 534 237	Oil Separator Repair kit	1
11 43 7 565 437	Dip Stick Guide Tube	1
11 15 7 532 629	Hose	1

E46 (3 Series) all-wheel drive only

Part Number	Description	Quantity
11 61 7 534 237	Oil Separator Repair kit	1
11 43 7 565 438	Dip Stick Guide Tube	1
11 15 7 532 629	Hose	1

E53 (X5)

Part Number	Description	Quantity
11 61 7 534 237	Oil Separator Repair kit	1
11 43 7 563 831	Dip Stick Guide Tube	1
11 15 7 532 628	Hose	1

E60 (5 Series)

Part Number	Description	Quantity
11 61 7 533 400	Oil Separator	1
11 43 7 565 440	Dip Stick Guide Tube	1
11 61 7 533 398	Hose	1

11 61 7 533 399	Hose	1
-----------------	------	---

E83 (X3)

Part Number	Description	Quantity
11 61 7 533 400	Oil Separator Repair kit	1
11 43 7 565 438	Dip Stick Guide Tube	1
11 61 7 533 398	Hose	1
11 61 7 533 399	Hose	1

E85 (Z4)

Part Number	Description	Quantity
11 61 7 533 400	Oil Separator	1
11 43 7 565 437	Dip Stick Guide Tube	1
11 61 7 533 398	Hose	1
11 61 7 533 399	Hose	1

WARRANTY INFORMATION

Covered under the terms of the BMW New Vehicle Limited Warranty or the BMW Certified Pre-Owned Program.

Please refer to the latest KSD for all applicable labor operations and allowances.

If the appropriate labor operation is not contained in KSD, then a work time labor operation should be used.

Defect Code	11 15 03 14 00
-------------	----------------