

SB-10045282-3617SI B11 07 12
EngineNovember 2012
Technical Service

This Service Information bulletin supersedes SI B11 07 12 **dated July 2012.**

NEW designates changes to this revision

SUBJECT**N63 Engine: Oil Consumption and/or Rough Running Complaints****MODEL**

E70

E71

F01

F02

F04

F07

F10

F12

F13

SITUATION

The vehicle may consume engine oil above the permissible specification, and may run rough at times. White or blue smoke may also be seen exiting the exhaust system.

CAUSE

The construction material of the crankcase ventilation connection lines and vent pipes may become brittle from engine compartment temperatures.

PROCEDURE**E70 and E71 produced to 3/2011****F01, F02, F04, F07, F10, F12, F13 produced to 1/2011**

1. Remove the engine cover and inspect the crankcase ventilation connecting lines (1) and (3).

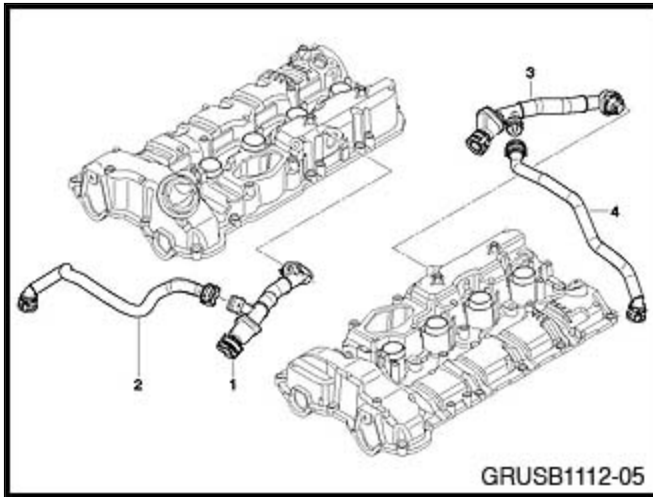

Each of the connecting lines will have an index number printed on the connection closest to the cylinder head cover.

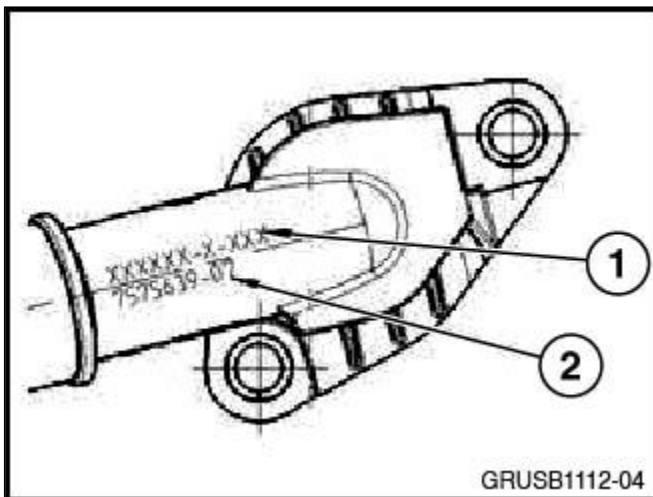

2. Production code (1)

Part Number and Index Number
(2)

Example : 7575639-07

The index number is separated from the 7-digit part number by a hyphen. In this example, it is "07".

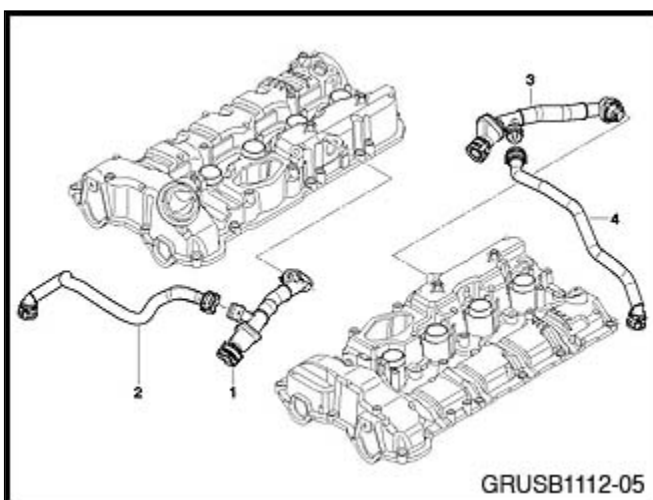

3. If the index number is "7" or lower, both crankcase ventilation connecting lines and vent pipes need to be replaced.

The improved replacement parts will have an index of "8" or higher.

(1) Connecting line bank 1

(2) Vent pipe bank 1

(3) Connecting line bank 2

(4) Vent pipe bank 2

4. Each cylinder head cover and vent pipe connection has two M6x18 screws attaching these components. The torque specification for these screws is 10 +/- 1.5 Nm.

Important: Do not replace the cylinder head covers for this complaint.

E70 and E71 produced from 3/2011

F01, F02 F04, F07, F10, F12, F13 produced from 1/2011

Inspect the crankcase ventilation connecting lines and vent pipes connections; if found loose, properly secure them.

Important: Do not replace the cylinder head covers for this complaint.

PARTS INFORMATION

| Part Number | Description | Quantity |
|-----------------|------------------------|----------|
| 11 15 7 575 642 | Connecting line bank 1 | 1 |
| 11 15 7 575 640 | Vent pipe bank 1 | 1 |
| 11 15 7 575 643 | Connecting line bank 2 | 1 |
| 11 15 7 575 641 | Vent pipe bank 2 | 1 |

WARRANTY INFORMATION

Covered under the terms of the BMW New Vehicle/SAV Limited Warranty or the BMW Certified Pre-Owned Program.

Defect Code: 11 15 00 48 00

| Labor Operation: | Labor Allowance: | Description: |
|------------------|------------------|-----------------------------------------|
| 11 15 006 | Refer to KSD2 | Replacing both engine ventilation lines |

NEW and

NEW E70 and E71

| | | |
|----------------------|---------|--------------------------------------------------------------------------------------------------|
| NEW 11 99 000 | 10 FRUs | Work time to replace both connecting lines with the replacement of both engine ventilation lines |
|----------------------|---------|--------------------------------------------------------------------------------------------------|

NEW or

NEW F01, F02, F04, F07, F10, F12 and F13

| | | |
|----------------------|--------|--------------------------------------------------------------------------------------------------|
| NEW 11 99 000 | 6 FRUs | Work time to replace both connecting lines with the replacement of both engine ventilation lines |
|----------------------|--------|--------------------------------------------------------------------------------------------------|

NEW Labor operation code 11 15 006 is a Main labor operation. If you are using a Main labor code for another repair, use the Plus code labor operation 11 15 506 instead.

NEW Refer to KSD2 for the corresponding flat rate unit (FRU) allowance. Enter the Chassis Number, which consists of the last 7 digits of the Vehicle Identification Number (VIN). Click on the "Search"

button, and then enter the applicable flat rate labor operation in the FR code field.

NEW Even though work time labor operation code 11 99 000 ends in “000,” it is not considered a Main labor operation.

[Copyright © 2012 BMW of North America, LLC]