

TRANSIT

CUSTOM



Go Further

Introducing the Ford Transit Custom

The Ford Transit Custom is remarkably efficient without compromising the famously generous loadspace. It's hardly surprising then, that it was awarded the prestigious International Van of the Year award at introduction in 2013.

1-2

Capable and clever

The loadspace has been maximised, towing capability optimised and everything tested over and over again, so you can tackle the toughest jobs with confidence.

3-4

Makes work a pleasure

The Transit Custom isn't just a great van, it's a great office. Car-like comfort, commanding driving position and a host of smart technologies let you take your business on the road.

5-6

Comfort and protection inside and out

With a complete suite of passive and active safety and driver assistance features, the Transit Custom employs the latest technology to help provide comfort and protection to driver, passengers and cargo.

7-8

Powerfully economic

The durable diesel technology of the Duratorq TDCi engine delivers the power and pulling muscle you need.

9-10

Make it yours

Choose from a range of colours and accessories to ensure your Transit Custom is stylish, practical and perfectly suited to your work needs.

11-12

Specifications



Transit Custom LWB shown with optional City Pack in Moondust Silver and Transit Custom SWB shown with optional City Pack in Frozen White (inset).



Overseas model shown.

Underseat stowage compartment

The front dual passenger seat cushion flips up to reveal a hidden compartment large enough to hold a toolbox.



Overseas model shown.

3-metre load length with load-through bulkhead

The Transit Custom can carry up to 3-metre long items, thanks to the standard flexible load-through bulkhead.



Tested to extremes

No matter how hard you push it, you'll never be as tough on the Transit Custom as we were. We ran it at maximum speed for two months. We took it from -40°C at 4,500-metre altitudes to towing fully-laden trailers in 50°C heat. We opened and closed the doors and bonnet over 250,000 times. We drove it hundreds of thousands of kilometres with real customers, and condensed 10 years of driving into a non-stop six month test, towing a fully-laden trailer. It's a van you know you can rely on.

Capable and clever

The Transit Custom is built for business. Huge loadspace, impressive pulling power and a host of handy storage and stowing features make it an indispensable working partner. And, because it's been tested to within an inch of its life, you know the Transit Custom will keep pulling its weight for years to come.



Transit Custom SWB shown with optional City Pack in Moondust Silver.

Impressive towing ability

With up to 2,500kg* (SWB)/2,800kg* (LWB) maximum towing capacity, the Transit Custom offers impressive pulling power along with a range of safety and driver assistance features to help keep you and your trailer secure. From Hill Launch Assist to Trailer Sway Control, you can tow with confidence and enjoy a rewarding drive.



Ample loadspace

There's no compromise in the most vital consideration for a working van: maximising your loadspace and the ease with which you can use it.

- SWB: 5.95 cubic metres of space
- LWB: 6.83 cubic metres of space
- 3-metre load length with load-through bulkhead
- Compartment tie down loops
- Sealed loadfloor
- Local compartment lighting

*When fitted with a Genuine Ford Tow Pack and towball. Subject to State & Territory regulations.



Transit Custom SWB shown with optional City Pack in Moondust Silver.

Handles everything with ease

The Transit Custom is the ideal choice for demanding city work. Torque Vectoring Control improves traction, roadholding and cornering by continuously optimising the engine torque distributed to each front wheel. Plus, stiffer mounting bushes and brackets enhance the Transit's already legendary ride and handling.



Stay connected with Ford SYNC®

Developed with Microsoft® the advanced software of Ford SYNC® lets you use detailed voice commands when making calls or playing music. Automatic phonebook downloading puts you in total control without taking your eyes off the road, plus your iPod,™ MP3 player or USB device seamlessly integrates with the Transit Custom's audio system.



Reverse camera

The optional City Pack offers a reverse camera, providing a wide-angle view behind the vehicle to help you see what – or who – is behind you when reversing.

Makes work a pleasure

You have enough to think about when you're working. That's why the Transit Custom has intelligent features to help lighten the load. Its car-like comfort makes work a pleasure, while high-quality materials give it a premium feel without compromising everyday practicality.



Overseas model shown.

A great working environment

It's easy to find the ideal driving position with a four-way adjustable driver's seat and a steering wheel that adjusts to height and arm length. The allergy-friendly materials of the interior and high-performance pollen filter will keep you breathing easy. And the cruise control's Adjustable Speed Limiting Device allows you to set a maximum speed that you do not wish to exceed (deactivated on full acceleration).

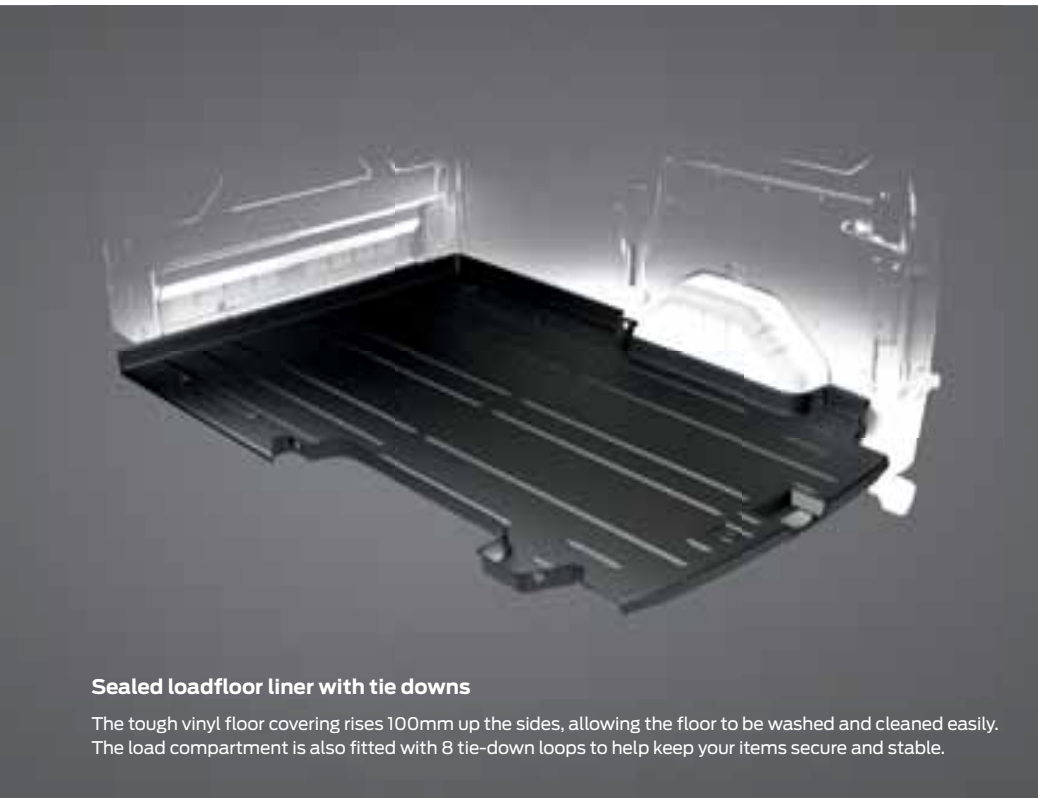

Sealed loadfloor liner with tie downs

The tough vinyl floor covering rises 100mm up the sides, allowing the floor to be washed and cleaned easily. The load compartment is also fitted with 8 tie-down loops to help keep your items secure and stable.



Ease of loading

The low cargo floor and sliding side door make loading and unloading by hand simple. Plus, the double rear doors fold at both 90° and 180° open angles, offering easy forklift and pallet access.

Trailer Sway Control

When it detects trailer sway, the system is designed to reduce engine torque and apply the brakes to the appropriate wheel(s) to help restore control.

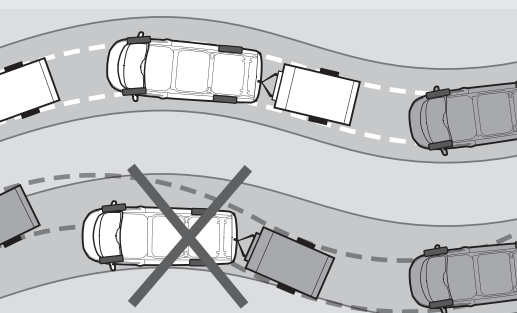

Dynamic Stability Control (DSC)

DSC is designed to help you maintain control in extreme driving conditions. It senses when you are deviating from your chosen line and aims to keep you on track by automatically regulating braking and engine output.

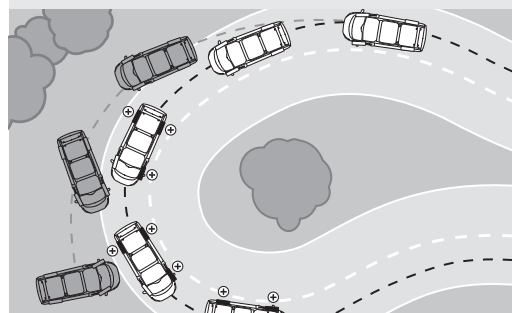

Hill Launch Assist

Temporarily prevents you from rolling down a slope when you move your foot from brake to accelerator. It works in forward and reverse gears, so is ideal for towing and pulling heavy loads.

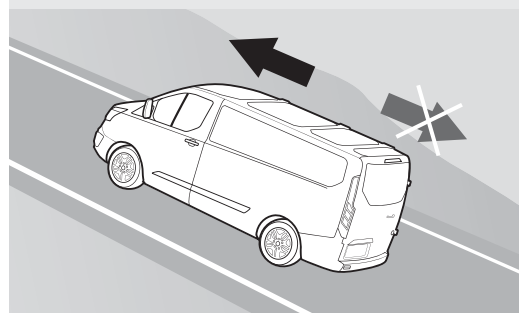

Roll-over mitigation

Reacts to a potentially dangerous driving situation by activating the DSC to restore stability.

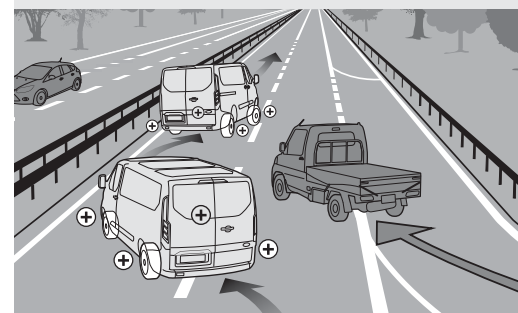

Load Adaptive Control

Adjusts the responses of the DSC system to compensate when the vehicle is unladen, partially or fully-laden.

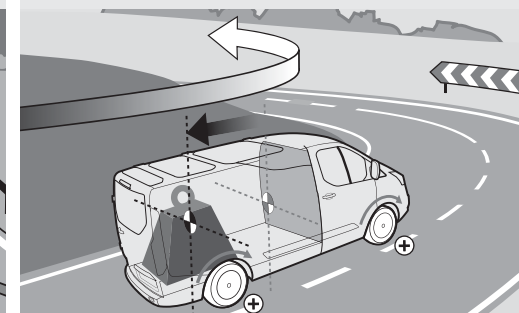

Six airbags standard

The Transit Custom's cab offers airbags positioned at the front, on both sides and at the head to enhance protection of the driver and passenger in the event of an accident.



Overseas model shown.

Comfort and protection inside and out

A full line up of passive and active safety and driver assistance features make use of the latest technology to help provide comfort and protection to the driver, passengers and cargo.



Traction Control

If wheel slip is detected at low speed, Traction Control mitigates wheel spin by reducing engine torque and applying brake pressure.

Emergency Brake Assist

Recognises an emergency braking situation and increases the pressure within the braking system to provide extra stopping power.

Emergency Brake Warning

Front and rear indicators automatically flash during heavy braking, giving other drivers advance hazard warning.

Transit Custom SWB shown with optional City Pack in Moondust Silver.

Powerfully economic

The highly-economic Duratorq TDCi diesel engine will give you years of reliable hauling and towing power.



Overseas model shown.



Duratorq TDCi engine

Featuring advanced high pressure common rail technology, the 2.2L Duratorq TDCi diesel engine in the SWB model delivers an impressive 92kW of power and 350 Nm of torque.* The Duratorq engine in the SWB achieves superb fuel economy* of 7.2L/100km while only producing 191g/km of CO₂.



Ford EcoMode driver information system

This smart software monitors your driving style and tells you when you're achieving optimal fuel efficiency.



Shift Indicator

The intelligent indicator advises you when to change gear for maximum fuel efficiency.

*Power and torque figures measured using premium unleaded fuel (95RON). *Based on SWB consumption figures of 7.2/100km. Fuel consumption and emissions as per ADR 81/02 (combined cycle) and to be used for vehicle comparison purposes only. It is unlikely that this fuel consumption figure will be achieved in real world driving conditions. Actual fuel consumption will depend on many factors including the driver's habits, prevailing conditions and the vehicle's equipment, condition and use.

Colours

Stylish but practical, choose your Transit Custom in a range of colours.



Trims Seat insert: Traxon in Charcoal Black Seat bolster: Max in Charcoal Black

Dimensions (mm)	SWB	LWB
A Overall length	4972	5339
B Overall width with/without mirrors extended	2290 / 1986	2290 / 1986
C Roof height (roof rack retracted/extended)	2007 / 2131	2022 / 2146
D Wheelbase	2933	3300
E Front overhang	1011	1011
F Rear overhang	1028	1028
G Width side door	1030	1030
H Height side door	1320	1320
I Rear door entry width	1400	1400
J Rear door entry height	1340	1340
K ¹ Minimum cargo loadspace length	2405	2772

Dimensions (mm) continued	SWB	LWB
K ² Maximum cargo loadspace length (at floor)	2555	2922
K ³ Maximum cargo length using underseat load extension	3085	3452
L Maximum loadspace width	1775	1775
M Loadspace between wheel arches	1390	1390
N Load floor to roof	1406	1406
O Loading height	545	559
P Loadspace maximum load volume [†] (m ³) single side load door (with bulkhead)	5.95	6.83
Turning Circle (m)	SWB	LWB
Kerb to kerb – 15" wheels	10.9	12.2

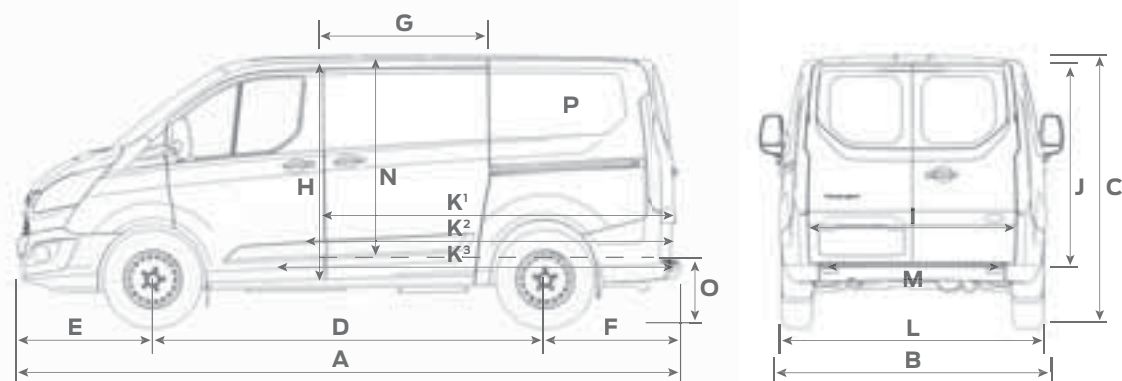

Line drawings not to scale and are included for the purpose of indicating dimension positions only – they are not representative of actual vehicle specifications.

*SWB shown with an optional City Pack. -Prestige paint is an option that incurs an additional charge. †Maximum load volume method simply measures the volume of a fine-grained material such as sand or rice which can be deposited into the loadspace.

Make it yours

Choose your accessories to turn your Transit into the perfect vehicle to meet your work needs.

Accessories

	290S SWB Van	330L LWB Van
Alloy wheel kit 16" x 6.5"	–	A
Reverse Camera (Got-Tech S.B.A)	A	A
Weathershields – slimline – tinted	A	A
Rear Window Grille Kit	A	A
Bonnet Protector	A	A
Interior Stowage Rack Kit (Maximum load 50kg)	A	A
Ladder Kit – Rear low roof only	A	A
Sports Stripes – Black	A	A
Tow Pack	A	A
Tow Pack LED trailer lights jumper connector	A	A
Carry Bars Rhino Rack Vortex	A	A
Carry bar ladder rack system	A	A



Ladder Kit

Attaches to the rear cargo door and allows easy access to the roof.



Tow Pack

Includes towbar, towball, trailer wiring module and trailer wiring kit. Rigorously tested to meet stringent Ford engineering standards and Australian Design Rules.



Weathershields

Set of two slimline front weathershields made from tinted, durable acrylic to help reduce window fogging and deflect wind and rain. UV resistant to help prevent cracking, fading and distortion.

Specifications For vehicles produced from May 2016¹

	SWB	LWB
Fuel economy & emissions		
Combined fuel economy (L/100km) ²	7.2	7.4
Fuel	Diesel	Diesel
Fuel tank capacity (Litres)	95	95
CO ₂ emissions (g/km) ²	191	197
Engine & performance		
Auto Stop/Start	S	S
2.2L TDCi engine	S	S
Battery – Twin	S	S
Power – Maximum (DIN)	92kW @ 3500rpm	
Torque – Maximum (DIN) Valves	350Nm @ 1450 – 2000rpm	
Transmission		
6-speed manual	S	
Transmission ratios		
1st	3.727	
2nd	1.864	
3rd	1.121	
4th	0.780	
5th	0.844	
6th	0.683	
Final drive	4.714	
Reverse	1.423	
Towing capacity – maximum (kg) braked ³	2500	2800
Towing capacity – maximum (kg) unbraked ³	750	
Safety, security & driver assistance		
Airbags – Driver & front passenger	S	
Airbags – Curtain	S	
Airbags – Side Thorax	S	
Cruise control with Adjustable Speed Limiting Device (ASLD)	S	
Brakes – Anti-lock Braking System (ABS)	S	
Brakes – Electronic Brakeforce Distribution (EBD)	S	
Brakes – Emergency Brake Assist (EBA)	S	
Dynamic Stability Control (DSC) with:		
- Hill Launch Assist		
- Roll over mitigation		
- Emergency Brake Warning		
- Load Adaptive Control	S	
- Torque Vectoring Control		
- Trailer Sway Control		
- Traction Control System (TCS)		
Rear window defroster	S	
Immobiliser – Passive Anti-theft System (PATS)	S	
Bonnet release – Key operated	S	
Locking – Remote central, 2 fobs provided	S	
Perimeter Alarm	S	
Reverse camera with front and rear sensors	P	

S = Standard P = Part of an Option Pack

1. Please consult your Ford Dealer to confirm vehicle production date. 2. Fuel consumption and emissions as per ADR 81/02 (combined cycle) and to be used for vehicle comparison purposes only. It is unlikely that this fuel consumption figure will be achieved in real world driving conditions. Actual fuel consumption will depend on many factors including the driver's habits, prevailing conditions and the vehicle's equipment, condition and use. 3. Towing is subject to State and Territory regulations. Maximum braked towing capacity when fitted with a Genuine Ford Tow Pack. Towball downforce must be taken into account when calculating

	SWB	LWB
Ride & handling		
Brakes		
Front and rear disc brakes	288mm	308mm
Suspension		
Front – Independent MacPherson struts, variable rate coil springs, stabiliser bar and gas pressured shock absorbers	S	
Rear – Single leaf springs, gas pressurised shock absorbers	S	
Steering		
Power assisted steering	S	
Turning circle – Kerb to kerb (m)	10.9	12.2
Wheels & Tyres		
Wheel size	6.5" x 15"	6.5" x 16"
Wheel type	Steel	
Tyre size	215/65 R15	215/65 R16
Rear configuration	Single	
Spare wheel	Steel	
Exterior features		
Roof height		
Low roof	S	
Styling		
Mudflaps – Front	S	
Mudflaps – Rear	S	
Lights		
Front Fog Lights	P	
Headlights – Follow-me-home	S	
Headlights – Levelling manual	S	
Headlights – Halogen	S	
High Mounted Stop Light	S	
Visibility		
Mirrors – Heated, power with side indicators	S	
Wipers – Front variable intermittent	S	
Stowage & carrying		
Doors – kerb side sliding (left side only)	S	
Doors – Rear glazed twin hinged with 90° hold and 180° opening	S	
Integrated roof rack with 130kg capacity	S	

Specifications continued

	SWB	LWB
Interior features		
Comfort & convenience		
Air conditioning – Manual front		S
Cruise control with leather wrapped steering wheel and adjustable speed limiter		S
Fold down tray table		S
Lighting – Dual front overhead		S
Power – 12V socket auxiliary		S
Power – 12V socket in driver stowage bin		S
Power – 12V socket in rear cargo area		S
Tachometer		S
Trip computer		S
Windows – Power front		S
Seats		
Seat adjustment – Driver 4-way manual, arm rest and lumbar with cushion tilt		S
Seats – Front passenger dual fixed with under seat stowage compartment		S
Heated Driver and Passenger seats		S
Trim – Cloth		S
Storage		
Bottle holders – Two 2 litre		S
Bulkhead – Full width steel with window and load through hatch		S
Cup holders – 2		S
Door – Storage pockets		S
Floor – Rubber		S
Lockable Glove box – With lid & A4 hanging file storage capability		S
Load area protection kit		S
Load – Compartment light		S
Load – 8 x compartment tie downs		S
Audio, communications & instruments		
2 speakers and 2 tweeters		S
3.5" Multi-functional display screen		S
Audio – Single CD player		S
Audio – Steering wheel mounted controls		S
Audio – USB connectivity port and Digital AM/FM radio		S
SYNC® ⁴ – In vehicle communications system including Bluetooth® ⁵ with phone and audio integration and voice control		S

S = Standard P = Part of an Option Pack

payload. Towball download must be a minimum of 10% of the towed weight. **4.** For SYNC® compatibility visit <http://www.ford.com.au/sync> **5.** Bluetooth® is a registered trademark of Bluetooth SIG Inc. and is used under licence. Customers should consult their Ford Dealer on the ability of their mobile phone handset to integrate with the Bluetooth® system prior to making a purchase decision. **6.** Maximum load volume method simply measures the volume of a fine-grained material such as sand or rice which can be deposited into the loadspace. **7.** Loadspace shown as VDA (measured in cubic metres). The VDA method measures volume in cubed litre blocks.

	SWB	LWB
Optional City Pack		
- Front and rear parking sensors		P
- Rear Camera		P
- Electrochromatic mirror with Camera Display		P
- Front Fog Lamps		P

Dimensions & weights

Cargo dimensions (mm)		
Width – Loadspace between wheel arches		1390
Width – Loadspace maximum		1775
Height – Loadspace floor to roof		1406
Length – Loadspace minimum	2405	2772
Length – Loadspace maximum (at floor)	2555	2922
Length – Under seat load extension		530
Maximum loadspace (m ³) ⁶ single side load door (with bulkhead)	5.95	6.83
Loadspace VDA (m ³) ⁷ single side load door (with bulkhead)	5.36	6.23
Exterior dimensions (mm)		
Length – Overall	4972	5339
Width – Overall with/without side mirrors extended		2290 / 1986
Roof height (roof rack retracted)	2007	2022
Roof height (roof rack extended)	2131	2146
Overhang – Front / rear		1011/1028
Wheelbase	2933	3300
Width – Rear / side door		1400 / 1030
Height – Rear / side door		1340 / 1320
Loading height (unladen) – Rear side door	545/508	559/520
Vehicle masses (kg)		
Axle load – Front / rear maximum	1550 / 1575	1725 / 2000
Gross combined mass	5100	5325
Gross vehicle mass	2900	3325
Kerb weight	1868	1965
Payload – Maximum	1032	1360



Quality

We design and build your Ford to feel as good after many years of service as it did the day you picked it up. And to drive just as beautifully, too.



Safety

Ford's Intelligent Protection System uses sophisticated technology designed to help prevent an accident and, if one should happen, to help protect you.



Sustainability

Using advanced technology, we're committed to creating vehicles with improved fuel economy, reduced CO₂ emissions and a lower overall cost of ownership.



Smart

Vehicles with smart, intuitive technologies designed to connect you to your world and many clever solutions that make life a little easier.

Speak to your Ford Dealer today about how we can help you make the most out of your vehicle ownership experience.

Warranties & Service.

3 year/100,000km new car warranty.#

For three years or 100,000km, whichever comes first, your Ford is covered against any defects in factory materials or workmanship. This also applies to Genuine Ford Accessories you may have had fitted before you took delivery.

5 year warranty against perforation corrosion.#

It's reassuring to know that the original body of your gleaming new Ford is guaranteed against perforation corrosion for the first five years of its life. If perforation corrosion occurs, we'll fix it for free.

myFord Warranties and Insurance.

When you first turn the key of your brand new Ford you want to do so without a care in the world. Our range of myFord products gives you that extra peace of mind. For more information about myFord Warranties and Insurance, visit your participating Ford Dealer for further details on the plans that best suit your needs. Terms, conditions and eligibility criteria apply.

Vancare Roadside Assistance.#

Our commitment to your complete satisfaction plays a major role in everything we do. That is why we provide Ford Vancare Roadside Assistance for all Ford Transit Customers. Wherever and whenever you need emergency roadside assistance, help is available 24 hours a day, 365 days a year.

If your vehicle breaks down and cannot be repaired, we will organise to transport your vehicle to the nearest Ford Dealer or approved service centre for repair. Ford Vancare Roadside Assistance is valid for 1 year from the vehicle's first registration.

12 months/15,000km service intervals.

Under normal driving conditions service intervals are 12 months or 15,000km, whichever occurs first.

FORD SERVICE

At Ford, we are committed to providing an outstanding ownership experience. For example, we think you should always know what you're going to pay for a standard service, before you go in. So we offer a Service Price Promise for the life of your car, which means we'll publish the maximum price you'll pay for your next A or B logbook service at participating Authorised Ford Dealers on all vehicles built from 2007.

However our service doesn't end at the service garage. With each standard service at a participating Auto Club Dealer, Retail and Small Business

Customers (fleets of less than five vehicles) will also receive up to 12 months Auto Club Membership (including free Roadside Assistance), for up to seven years. Eligible customers will even have access to a free loan car with any scheduled service, through participating dealers. Why do we do all this? Because at Ford, we think that's what service should be.

For more details visit your participating local Ford Dealer or visit ford.com.au/service/t-and-c for full terms and conditions.

Want to contact us?

For answers to your questions, or help with any concern, contact our Customer Relationship Centre on 13 FORD (13 3673) or email customers@fordrc.com.au

Visit us on the web.

If you want more information on Ford or our entire product range, visit us at ford.com.au

Running a fleet?

Our Ford Fleet team is available to assist fleet customers with information on Ford products and services. Call 1300 13 13 30 or email askfleet@ford.com

#Conditions and exclusions apply. For more information consult your authorised Ford Dealer.

This brochure details specifications and features of the Transit Custom. Some driver assistance features and safety features described in this brochure are designed to function using sensors, whose performance may be affected under certain weather or environmental conditions. Not all features will be available on the entire Transit Custom model range. Please visit our website www.ford.com.au for more information.

This brochure is designed to provide you with a general introduction to the Ford Products (including available optional equipment) referred to, and should be read in conjunction with the latest specification sheet. Image and Illustrations are for information purposes and are indicative only. Because of changes in conditions and circumstances Ford* reserves the right, subject to all applicable laws, at any time, at its discretion, and without notice, to discontinue or change the features, designs, materials, colours and other specifications and the prices of its products, and to either permanently or temporarily withdraw any such products from the market without incurring any liability to any prospective purchaser or purchasers. The latest specification sheet should be referred to for information on the availability, ordering and use of features and optional equipment. Always consult an authorised Ford Dealer for the latest information with respect to features, specifications, prices, optional equipment and availability before deciding to place an order.

*FORD MOTOR COMPANY OF AUSTRALIA LIMITED. (A.B.N. 30 004 116 223) Registered Office: Level 1, 600 Victoria St, Richmond, Victoria 3121, Australia. Transit Custom Brochure. Printed August, 2016. BHFO00175 FRD0002086



Go Further

Click to Request



Quote



Hot Deals



Test Drive