

ALL-NEW **TRANSIT** CUSTOM



Go Further

Introducing the all-new Ford Transit Custom

The all-new Ford Transit Custom sets a new benchmark for efficiency without compromising the famously generous loadspace. It's hardly surprising then, that it's already been awarded the prestigious International Van of the Year award 2013.

1-2

Capable and clever

The loadspace has been maximised, towing capability[^] optimised and everything tested over and over again, so you can tackle the toughest jobs with confidence.

3-4

Makes work a pleasure

The all-new Transit Custom isn't just a great van, it's a great office. Car-like comfort, commanding driving position and a host of smart technologies let you take your business on the road.

5-6

Protection inside and out

With a complete suite of passive and active safety features, the all-new Transit Custom employs the latest technology to help protect driver, passengers and cargo.

7-8

Powerfully economic

The durable diesel technology of the Duratorq TDCI engine delivers the power and pulling muscle you need, together with tested fuel economy unsurpassed by any other one-tonne van in Australia.*

9

Colours and trim

10-12

Specifications



All-new Transit Custom shown with optional City Pack in Moondust Silver and Frozen White (inset).

[^]Towpack is currently unavailable. Please check with your local Ford Dealer for availability of the Genuine Ford Towpack. *Based on fuel consumption figures of 7.1L/100km, tested to ADR 81/02 (combined cycle). Actual fuel consumption will depend on many factors including driving habits, prevailing conditions and your vehicle's equipment, condition and use.

Capable and clever

The all-new Transit Custom is built for business. Huge loadspace, impressive pulling power[^] and a host of handy storage and stowing features make it an indispensable working partner. And, because it's been tested to within an inch of its life, you know the all-new Transit Custom will keep pulling its weight for years to come.



Overseas model shown.

Underseat stowage compartment

The front dual passenger seat cushion flips up to reveal a hidden compartment large enough to hold a toolbox.



Overseas model shown.

3-metre load length with load-through bulkhead

The all-new Transit Custom can carry up to 3-metre long items, thanks to the standard flexible load-through bulkhead.



Tested to extremes

No matter how hard you push it, you'll never be as tough on the all-new Transit Custom as we were. We ran it at maximum speed for two months. We took it from -40°C at 4,500-metre altitudes to towing fully-laden trailers in 50°C heat. We opened and closed the doors and bonnet over 250,000 times. We drove it hundreds of thousands of kilometres with real customers, and condensed 10 years of driving into a non-stop six month test, towing a fully-laden trailer. It's a van you know you can rely on.



All-new Transit Custom shown with optional City Pack in Moondust Silver.

Impressive towing ability[^]

With up to 2,500kg* maximum towing capacity, the all-new Transit Custom offers impressive pulling power along with a range of safety features to help keep you and your trailer secure. From Hill Launch Assist to Trailer Sway Control, you can tow with confidence and enjoy a rewarding drive.



Ample loadspace

There's no compromise in the most vital consideration for a working van: maximising your loadspace and the ease with which you can use it.

- 5.95 cubic metres of space
- 3-metre load length with load-through bulkhead
- Compartment tie down loops
- Sealed loadfloor
- Local compartment lighting

[^]Towpack is currently unavailable. Please check with your local Ford Dealer for availability of the Genuine Ford Towpack. *When fitted with a Genuine Ford towpack and towball. Subject to State & Territory regulations.



Handles everything with ease

The short wheelbase all-new Transit Custom is the ideal choice for demanding city work. Torque Vectoring Control improves traction, roadholding and cornering by continuously optimising the engine torque distributed to each front wheel. Plus, new stiffer mounting bushes and brackets enhance the Transit's already legendary ride and handling.

All-new Transit Custom shown with optional City Pack in Moondust Silver



Stay connected with Ford SYNC™

Developed with Microsoft® the advanced software of Ford SYNC™ lets you use detailed voice commands when making calls or playing music. Automatic phonebook downloading puts you in total control without taking your eyes off the road, plus your iPod, MP3 player or USB device seamlessly integrates with the all-new Transit Custom's audio system.

®iPod is a trademark of Apple Inc.



Reverse camera

The optional City Pack offers a reverse camera, providing a wide-angle view behind the vehicle to help you see what – or who – is behind you when reversing.

Makes work a pleasure

You have enough to think about when you're working. That's why the all-new Transit Custom has intelligent features to help lighten the load. Its car-like comfort makes work a pleasure, while high-quality materials give it a premium feel without compromising everyday practicality.



Overseas model shown.

A great working environment

It's easy to find the ideal driving position with a four-way adjustable driver's seat and a steering wheel that adjusts to height and arm length. The allergy-friendly materials of the interior and high-performance pollen filter will keep you breathing easy. And the cruise control's Adjustable Speed Limiting Device allows you to set a maximum speed that you do not wish to exceed (deactivated on full acceleration).

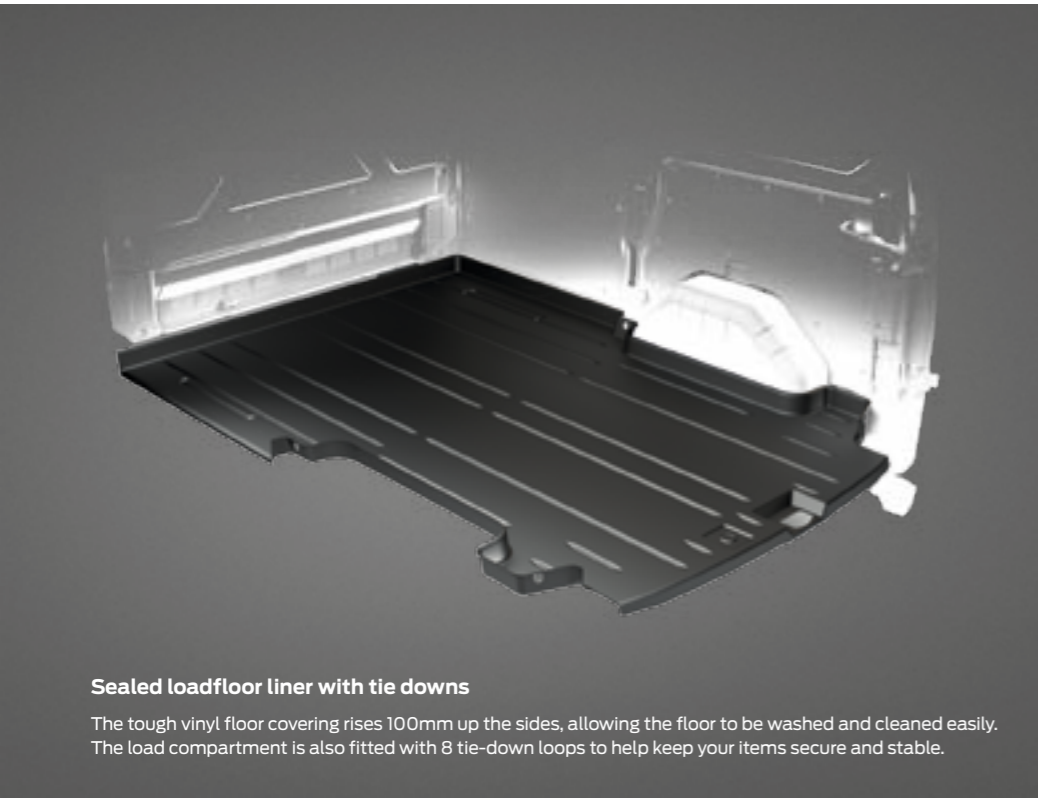

Sealed loadfloor liner with tie downs

The tough vinyl floor covering rises 100mm up the sides, allowing the floor to be washed and cleaned easily. The load compartment is also fitted with 8 tie-down loops to help keep your items secure and stable.



Ease of loading

The low cargo floor and sliding side door make loading and unloading by hand simple. Plus, the double rear doors fold at both 90° and 180° open angles, offering easy forklift and pallet access.

Trailer Sway Control

When it detects trailer sway, the system is designed to reduce engine torque and apply the brakes to the appropriate wheel(s) to help restore control.

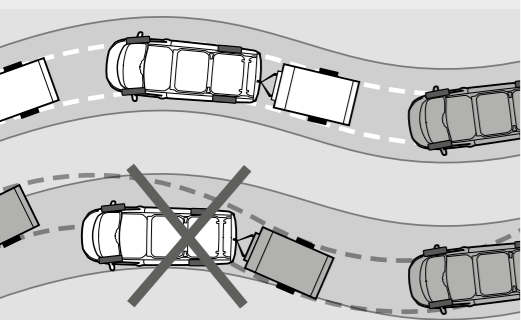

Dynamic Stability Control (DSC)

DSC is designed to help you maintain control in extreme driving conditions. It senses when you are deviating from your chosen line and aims to keep you on track by automatically regulating braking and engine output.



Hill Launch Assist

Temporarily prevents you from rolling down a slope when you move your foot from brake to accelerator. It works in forward and reverse gears, so is ideal for towing and pulling heavy loads.

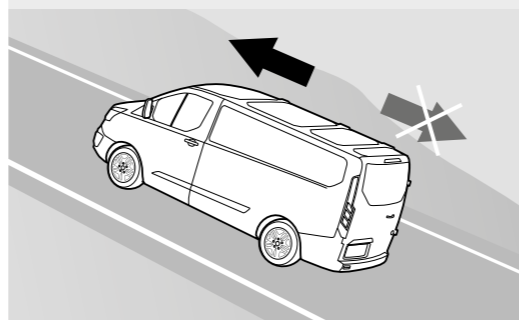

Roll-over mitigation

Reacts to a potentially dangerous driving situation by activating the DSC to restore stability.

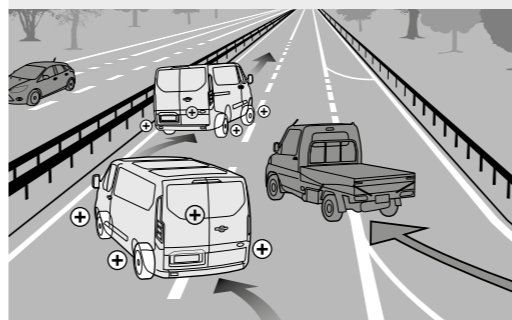

Load Adaptive Control

Adjusts the responses of the DSC system to compensate when the vehicle is unladen, partially or fully-laden.

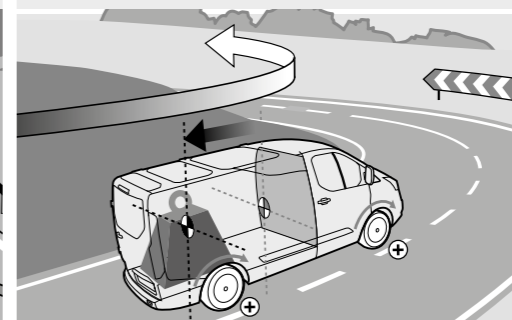

Six airbags standard

The all-new Transit Custom's cab offers airbags positioned at the front, on both sides and at the head to enhance protection of the driver and passenger in the event of an accident.



Overseas model shown.

Protection inside and out

A full line up of passive and active safety features make use of the latest technology to help protect the driver, passengers and cargo.



Traction Control

If wheel slip is detected at low speed, Traction Control mitigates wheel spin by reducing engine torque and applying brake pressure.

Emergency Brake Assist

Recognises an emergency braking situation and increases the pressure within the braking system to provide extra stopping power.

Emergency Brake Warning

Front and rear indicators automatically flash during heavy braking, giving other drivers advance hazard warning.

All-new Transit Custom shown with optional City Pack in Moondust Silver.



Overseas model shown.



Ford EcoMode driver information system

This smart software monitors your driving style and tells you when you're achieving optimal fuel efficiency.



Shift Indicator

The intelligent indicator advises you when to change gear for maximum fuel efficiency.

Powerfully economic

The Duratorq TDCI diesel engine will give you years of reliable hauling and towing power, while also delivering tested fuel economy unbeaten by any other one-tonne van in Australia.*



Proven Duratorq TDCi engine

Featuring advanced high pressure common rail technology, the 2.2L Duratorq TDCI diesel engine delivers an impressive 92kW of power and 350 Nm of torque. The Duratorq engine achieves fuel economy of 7.1L/100km while only producing 186g/km of CO₂. They're numbers that can't be beaten by any other one-tonne van in Australia.*

*Power and torque figures measured using premium unleaded fuel (95RON). *Based on fuel consumption figures of 7.1L / 100km, tested to ADR 81/02 (combined cycle). Actual fuel consumption and emissions will depend on many factors including driving habits, prevailing conditions and your vehicles equipment, condition and use.

Make it yours

Stylish but practical, choose your all-new Transit Custom in no-nonsense white or stylish silver.

Size matters

The all-new Transit Custom is compact enough for easy city use, while ingeniously maximising interior space.



Frozen White*



Moondust Silver**

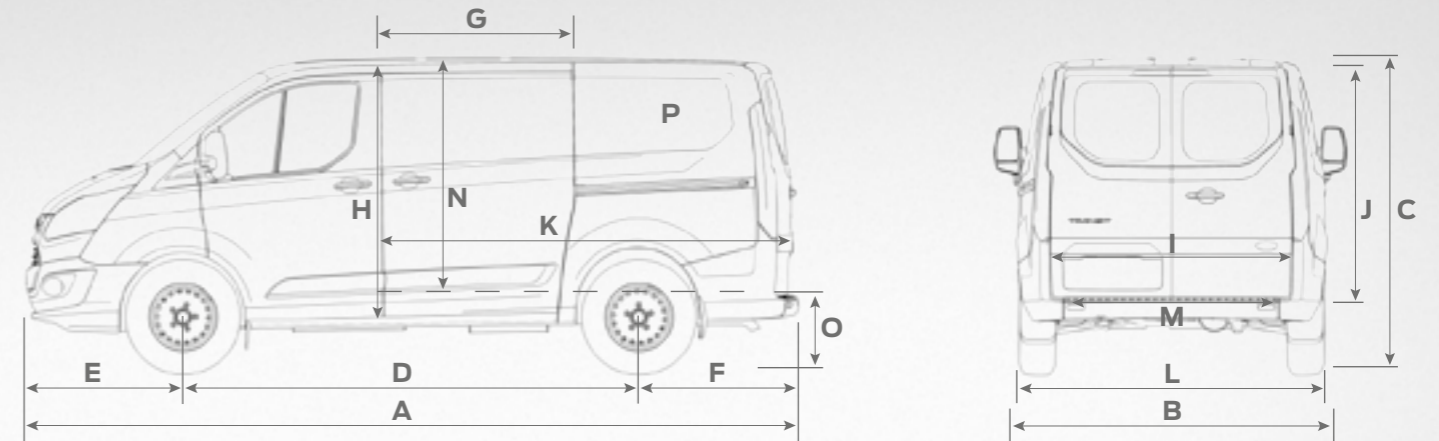

Line drawings not to scale and are included for the purpose of indicating dimension positions only - they are not representative of actual vehicle specifications.

Dimensions (mm)

A	Overall length	4972
B	Overall width with/without mirrors	2290 / 1986
C	Height overall (unladen) with roof rack stowed down	1972
D	Wheelbase	2933
E	Front overhang	1011
F	Rear overhang	1028
G	Width side door	1030
H	Height side door	1320
I	Rear door/tailgate entry width	1400
J	Rear door/tailgate entry height	1340
K	Maximum loadspace length (with bulkhead)	2555
L	Maximum loadspace width	1775
M	Loadspace between wheel arches	1390
N	Load floor to roof	1406
O	Loading height unladen	586
P	Load space SAE (m ³) single side load door (with bulkhead)	5.95

Turning Circle (m)

Kerb to kerb – 15" wheels	10.9
Wall to wall – 15" wheels	11.6



Trims

Seat insert: Traxon in Charcoal Black
Seat bolster: Max in Charcoal Black

Specifications

Fuel economy & emissions

Combined fuel economy (L/100km) ¹	7l
Fuel	Diesel
Fuel tank capacity (Litres)	95
CO ₂ emissions (g/km) ¹	186

Engine & performance

2.2L TDCi engine	S
Battery - Twin	S
Power - Maximum (DIN)	92kW @ 3500rpm
Torque - Maximum (DIN) Valves	350Nm @ 1450 - 2000rpm

Transmission

6-speed manual	S
----------------	---

Transmission ratios

1st	3.727
2nd	1.864
3rd	1.121
4th	0.780
5th	0.844
6th	0.683
Final drive	4.190
Reverse	1.423
Towing capacity - maximum (kg) braked ²	2500
Towing capacity - maximum (kg) unbraked ²	750

Safety & security

Airbags - Driver & front passenger	S
Airbags - Curtain	S
Airbags - Side Thorax	S
Cruise control with Adjustable Speed Limiting Device (ASLD)	S
Brakes - Anti-lock Braking System (ABS)	S
Brakes - Electronic Brakeforce Distribution (EBD)	S
Brakes - Emergency Brake Assist (EBA)	S
Dynamic Stability Control (DSC) with:	
- Hill Launch Assist	
- Roll over mitigation	
- Emergency Brake Warning	
- Load Adaptive Control	S
- Torque Vectoring Control	
- Trailer Sway Control	
- Traction Control System (TCS)	
Rear window defroster	S
Immobiliser - Passive Anti-theft System (PATS)	S
Bonnet release - Key operated	S
Locking - Remote central, 2 fobs provided	S
Perimeter Alarm	S
Reverse camera with front and rear sensors	P

Ride & handling

Brakes

Front and rear disc brakes	288mm
----------------------------	-------

Suspension

Front - Independent MacPherson struts, variable rate coil springs, stabiliser bar and gas pressured shock absorbers	S
Rear - Single leaf springs, gas pressurised shock absorbers	S

Steering

Power assisted steering	S
Turning circle - Kerb to kerb (m)	10.9

Wheels & Tyres

Wheel size	6.5" x 15"
Wheel type	Steel
Tyre size	215/65 R15
Rear configuration	Single
Spare wheel	Steel

Exterior features

Roof height

Low roof	S
----------	---

Styling

Mudflaps - Front	S
Mudflaps - Rear	S

Lights

Front Fog Lights	P
Headlights - Follow-me-home	S
Headlights - Levelling manual	S
Headlights - Halogen	S
High Mounted Stop Light	S

Visibility

Mirrors - Heated, power with side indicators	S
Wipers - Front variable intermittent	S

Stowage & carrying

Doors - kerb side sliding (left side only)	S
Doors - Rear glazed twin hinged with 90° hold and 180° opening	S
Integrated roof rack with 130kg capacity	S

S = Standard P = Part of an Option Pack

1. Figures obtained from controlled tests using ADR 81/02 combined. Actual fuel consumption and emissions will depend on many factors including driving habits, prevailing conditions and your vehicle's equipment, condition and use. 2. Towpack is currently unavailable. Please check with your local Ford Dealer for availability of the Genuine Ford Towpack. Towing is subject to State and Territory regulations. Maximum braked towing capacity when fitted with a Genuine Ford towpack. Tow ball downforce must be taken into account when calculating payload. Tow ball download must be a minimum of 10% of the towed weight. 3. For SYNC™ compatibility visit fordsync.com.

Specifications continued

Interior features**Comfort & convenience**

Air conditioning - Manual front	S
Cruise control with leather wrapped steering wheel and adjustable speed limiter	S
Fold down tray table	S
Lighting - Dual front overhead	S
Power - 12V socket auxiliary	S
Power - 12V socket in driver stowage bin	S
Power - 12V socket in rear cargo area	S
Tachometer	S
Trip computer	S
Windows - Power front	S

Seats

Seat adjustment - Driver 4-way manual, arm rest and lumbar with cushion tilt	S
Seats - Front passenger dual fixed with under seat stowage compartment	S
Heated Driver and Passenger seats	S
Trim - Cloth	S

Storage

Bottle holders - Two 2 litre	S
Bulkhead - Full width steel with window and load through hatch	S
Cup holders - 2	S
Door - Storage pockets	S
Floor - Rubber	S
Glove box - With lid & A4 hanging file storage capability	S
Load area protection kit	S
Load - Compartment light	S
Load - 8 x compartment tie downs	S

Audio, communications & instruments

2 speakers and 2 tweeters	S
3.5" Multi-functional display screen	S
Audio - Single CD player	S
Audio - Steering wheel mounted controls	S
Audio - USB connectivity port and Digital AM/FM radio	S
SYNC™ ³ - In vehicle communications system including Bluetooth® ⁴ with phone and audio integration	S

Options**City Pack**

- Front and rear parking sensors	P
- Rear Camera	P
- Electrochromatic mirror with Camera Display	P
- Front Fog Lamps	P

Dimensions & weights**Cargo dimensions (mm)**

Width - Load space between wheel arches	1390
Width - Load space maximum	1775
Height - Load space floor to roof	1406
Length - Load space maximum	2555
Length - Under seat load extension	530
Load space SAE (m ³) ⁵ single side load door (with bulkhead)	5.95

Exterior dimensions (mm)

Length - Overall	4972
Width - Overall with/without side mirrors	2290 / 1986
Height - Overall (Unladen) with roof rack stowed down	1972 - 2020
Overhang - Front / rear	1011/1028
Wheelbase	2933
Width - Rear / side door	1400 / 1030
Height - Rear / side door	1340 / 1320
Loading height - Unladen	586

Vehicle masses (kg)

Axle load - Front / rear maximum	1550 / 1575
Gross combined mass	5100
Gross vehicle mass	2900

S = Standard P = Part of an Option Pack

4. Bluetooth® is a registered trademark of Bluetooth SIG Inc. and is used under licence. Customers should consult their Ford Dealer on the ability of their mobile phone handset to integrate with the Bluetooth® system prior to making a purchase decision. 5. Load space shown as SAE (measured in cubic meters). The SAE method measures the volume of a fine-grained material, such as sand, which can be deposited into the load space.



Quality

We design and build your Ford to feel as good after many years of service as it did the day you picked it up. And to drive just as beautifully, too.



Sustainability

Using advanced technology, we're committed to creating vehicles with improved fuel economy, reduced CO₂ emissions and a lower overall cost of ownership.



Safety

Ford's Intelligent Protection System uses sophisticated technology designed to help prevent an accident and, if one should happen, to help protect you.



Smart

Vehicles with smart, intuitive technologies designed to connect you to your world and many clever solutions that make life a little easier.

Speak to your Ford Dealer today about how we can help you make the most out of your vehicle ownership experience.

3 year/100,000km new car warranty#

For three years or 100,000km, whichever comes first, your Ford is covered against any defects in factory materials or workmanship. This also applies to Genuine Ford Accessories you may have had fitted before you took delivery.

5 year warranty against perforation corrosion.#

It's reassuring to know that the original body of your gleaming new Ford is guaranteed against perforation corrosion for the first five years of its life. If perforation corrosion occurs, we'll fix it for free.

myFord Warranties and Insurance.

When you first turn the key of your brand new Ford you want to do so without a care in the world. Our range of myFord products gives you that extra peace of mind. For more information about myFord Warranties and Insurance, visit your participating Ford Dealer for further details on the plans that best suit your needs. Terms, conditions and eligibility criteria apply.

12 months/15,000km service intervals.

Under normal driving conditions service intervals are 12 months or 15,000km, whichever occurs first.

Running a fleet?

Our Ford Fleet team is available to assist fleet customers with information on Ford products and services. Call 1300 13 13 30 or email askfleet@ford.com

Want to contact us?

For answers to your questions, or help with any concern, contact our Customer Relationship Centre on 13 FORD (13 3673) or email customers@fordcrc.com.au

Visit us on the web.

If you want more information on Ford or our entire product range, visit us at ford.com.au

myFord Capped Price Servicing.

Your new Ford vehicle now gives you access to myFord Capped Price Servicing, which means it makes even more sense to have your Ford looked after by the people who know your Ford back to front, inside and out. With myFord Capped Price Servicing, Ford will publish the maximum price you will pay for a standard A or B logbook service at participating Authorised Ford Dealers for all vehicles built from 2007 up to 7 years or 105,000 kilometres, whichever comes first.

In addition, when vehicles are serviced under myFord Capped Price Servicing, Retail and Blue Business Fleet customers will also receive 12 months myFord Standard Roadside Assistance (RRP \$90).

For more details visit your local Ford Dealer or visit ford.com.au/myfordcps for full terms and conditions.



Vancare Roadside Assistance#

Our commitment to your complete satisfaction plays a major role in everything we do. That is why we provide Ford Vancare Roadside Assistance for all Ford Transit Customs. Wherever and whenever you need emergency roadside assistance, help is available 24 hours a day, 365 days a year. If your vehicle breaks down and cannot be repaired, we will organise to transport your vehicle to the nearest Ford Dealer or approved service centre for repair. Ford Vancare Roadside Assistance is valid for 1 year from the vehicle's first registration.

Click to Request



Quote



Hot Deals



Test Drive

#Conditions and exclusions apply. For more information visit ford.com.au/newvehiclewarranties

This brochure details specifications and features of the all-new Transit Custom. Please consult your Ford Dealer for the most recent specification and availability information.

This brochure is designed to provide you with a general introduction to the Ford Products (including available optional equipment) referred to, and should be read in conjunction with the latest specification sheet. Because of changes in conditions and circumstances Ford reserves the right, subject to all applicable laws, at any time, at its discretion, and without notice, to discontinue or change the features, designs, materials, colours and other specifications and the prices of its products, and to either permanently or temporarily withdraw any such products from the market without incurring any liability to any prospective purchaser or purchasers. The latest specification sheet should be referred to for information on the availability, ordering and use of features and optional equipment. Always consult an authorised Ford Dealer for the latest information with respect to features, specifications, prices, optional equipment and availability before deciding to place an order.

*FORD MOTOR COMPANY OF AUSTRALIA LIMITED. (A.B.N. 30 004 116 223) Registered Office: 1735 Sydney Road, Campbellfield, Victoria 3061, Australia. Printed February, 2014. FTRA0022. All-new Transit Custom Brochure. FRD001703



Go Further

ford.com.au