

Caprice



Bluetooth® is a registered trademark and logo of Bluetooth SIG, Inc.
Bose® is a registered trademark of Bose Corporation

A word about this catalogue. We have tried to make this catalogue as comprehensive and factual as possible. However, since the time of printing some of the information you'll find here may have been updated. Also, some of the equipment shown or described through this catalogue may have been changed and / or is available at extra cost. Further, GM Holden Ltd ABN 84 006 893 232, reserves the right to make changes at any time without notice, in prices, colours, materials, equipment and models. Your Holden Dealer has details, and before ordering, you should ask them to bring you up to date. No Holden Dealer or other person is authorised or permitted to give or make any statement, assertion or undertaking in relation to the quality, performance characteristics, descriptions or fitness for any purpose of any Holden product which is at variance with any written statement, assertion or undertaking on any of these subjects given or made by GM Holden Ltd in its published sales literature, and GM Holden Ltd does not accept any liability for any such unauthorised action. GM Holden Ltd has authorised Dealers in many parts of Australia for the sale of service parts and the provision of service to owners of Holden's products. Every endeavour is made to ensure that such Dealers carry adequate stocks of service parts, but GM Holden Ltd doesn't make any promise other than that contained in the New Vehicle Warranty given by GM Holden Ltd that such parts or service facilities will be available at any specific location or at any particular time. Express warranties offered for Holden products are subject to the conditions set out in all vehicle handbooks. Details also available from GM Holden Ltd on request. Copyright GM Holden Ltd. September 2008. emerystudio CAPWM0808 AD12650

Driving as you always imagined it



Corners straighten. Distances shorten. Heads turn – and stay turned. This is driving as you always imagined it. As you always wanted it. As you always knew it would be.

Supreme power. Sublime handling. Superb luxury. Unified, distilled, unleashed. The Holden Caprice embodies sports-inspired performance and automotive refinement at its absolute, breathtaking best.

In a class of its own – with a class all its own – this is motoring sophistication for a new generation of discerning drivers.

Its time is now. So is yours. Go first class.

Most vehicles have a best angle – the Caprice has 360° of them.

Head on, the sculpted front-end gives the vehicle an immensely powerful on-road presence.

In profile, the Caprice reveals itself as a body with soul – the short front overhang, sports-styled 18 inch alloys, distinctive wheel arches, sweeping chrome highlights and low slung dynamic proportions.

From behind, the fastback roofline, distinctly tapered boot, LED tail lights and quad exhaust outlets bring the vehicle to an unforgettable conclusion.

Exterior details also show a degree of flair. Bi-Xenon headlamps, with automatic washers, seemingly turn night into day. Sensing rain, the flat blade front wipers activate and adjust according to how heavily it's falling. Side mirror 'puddle' lamps can be switched on when remotely unlocking your vehicle, to help you never put a foot wrong when entering the cabin.

It all goes together perfectly. As does the selection of quality accessories, such as the leather wrap sports steering wheel or satellite navigation with full-colour mapping, you can use to individualise your Caprice.

An immensely powerful on-road presence





Impossible to resist

Razor sharp sports dynamics coupled with a true five-star luxury ride. Once, impossible to imagine. Now, courtesy of Caprice's revolutionary new Linear Control Suspension, impossible to resist.

Based on an advanced front and rear multi-link design, with forward mounted variable ratio steering, the Caprice's suspension architecture gives the vehicle an agility that belies its size.

Supple through the bends. Centred on the open road. No traditional luxury car vagueness or isolation. Just intuitive, precise handling, a palpable road connection and a ride unwavering in grace and composure.

All of it powered by Holden's 260kW* Generation 4 Alloy V8 engine. Shifted seamlessly by a six-speed automatic transmission with Active Select. And brought to a rapid, controlled stop by powerful, ventilated disc brakes on all four wheels. Every moment of every journey overseen – unobtrusively – by the vehicle's finely calibrated Electronic Stability Control, complete with Traction Control System, Anti-lock Braking System, Electronic Brake Assist and Electronic Brakeforce Distribution.

Perfect for when the road beckons to be driven. Perfect for effortless, long distance touring. Perfect, full stop.

Once you go first class, there's no turning back.

*Figure quoted using 98 RON (PULP)

The world's toughest proving ground

To ensure the Caprice passes the ultimate test – your total driving satisfaction – it was subjected to years of unrelenting examination on the world's toughest proving ground: Australia. And when winter ice proved in short supply, Holden flew the vehicle to Sweden and New Zealand and tested it there as well.

Refined, analysed and refined again, its Linear Control Suspension evolved into the most advanced suspension architecture ever developed for a Holden vehicle. A system totally at home in any of Australia's diverse driving conditions, and unsurpassed by even the most revered European sports luxury sedans.

Safety research was equally exhaustive. Indeed, the Caprice was crash-tested under virtually every imaginable real world scenario, with a range of crash test dummies representing virtually every size and shape of driver and passenger possible.

All throughout the vehicle's development, no idea was too big and no detail too small. An entire production line was stripped and rebuilt to ensure the narrowest interior fit and finish tolerances in Holden's history. Dozens of tyre compounds were trialled on the test track. And 60 different music genres used to tune the high-end audio system.

And yet impressive as all this may sound, it's still just a sample of what went into creating the Caprice. So just imagine the enjoyment you'll get from driving it.





A sleek, urbane aesthetic

The luxury treatment begins before you even set foot in the cabin. One touch of your remote key and your individual preferences take immediate effect. From the side mirror positions to your powered seat settings. Radio station presets to your trip computer personalisation. And once your key is in the ignition, the tri-zone climate control activates to your personal preferences.

Inside, the vehicle's sports pedigree is obvious. The refinement and attention to detail, unmistakable. The lush, dark-coloured ceiling and pillars. The bold aluminium accents. The exquisite 'soft-touch' tailored leather and suede in understated tones. Contrasted, they engender a sleek, urbane aesthetic with a distinct, performance-oriented edge.

For a vehicle of awesome power, there is an audio system to match. Bose®, of course. With a six-disc CD stacker and 10 speakers – including sub-woofers and roof-mounted centre speaker – it delivers 220 watts of incomparable surround sound.

And while you enjoy audiophile quality music, rear seat passengers can enjoy DVDs on screens incorporated into the back of each front seat headrest.

With so much quality entertainment going on, the Caprice's theatre lighting – which slowly dims interior lights to a soft, ambient glow – will come as no surprise. Nor the myriad of other thoughtful touches, such as a centre front armrest. Retractable rear seat cupholders. And a centre fold-down rear seat armrest, complete with storage tray.

Focus, not excess

The Caprice's driver-centric dashboard makes you master of all you survey – maximising your road view and placing all essential vehicle information in your immediate line of sight.

From speed and engine revs to real-time trip metrics, audio system status and tyre pressure alerts – plus turn-by-turn street directions, with the optional satellite navigation installed – you're in a position to monitor every detail with your eyes ahead for optimal driving control.

The four analogue instruments and three multifunction displays in the primary cluster are supplemented by the high-resolution full colour LCD display in the centre instrument panel – a unit that shows individual climate control settings, the electronic parking sensor display and more, including DVDs, when the vehicle is stationary.

Commonly used functions, such as the integrated hands-free Bluetooth® mobile phone system for compatible mobile phones, can be operated via fingertip controls mounted either side of the leather grip steering wheel. Other controls are placed intuitively and, through ergonomic use of satin chrome finishes and tactile rubber grips, operate intuitively. By your side – seat, window and mirror controls. Overhead – lighting and DVD controls, plus climate control and entertainment controls for rear seat passengers.

The vehicle even features night panel illumination, which helps reduce driver fatigue by dimming all interior lighting to leave only the speedometer illuminated. A huge plus for long distance driving after dark.

In the Caprice, it really is all systems go.



Reassuringly cold to the touch, accents of genuine pressed aluminium give the Caprice a bold and modern aesthetic.



Up to four times brighter than regular halogen bulbs, Bi-Xenon headlamps help penetrate the distance to improve night driving safety.





The remote controlled DVD player shows DVDs through LCD screens integrated into the back of the front seat headrests, with sound channelled through stereo headsets.



The twin needle stitched seats combine exquisite 'soft-touch' leather seat trim with micro-perforated leather inserts for optimal comfort and support.



For enhanced occupant safety, the Caprice features a total of six airbags: dual-stage front airbags, side impact airbags for the driver and front passenger, and side curtain airbags.



Stylish and safety-oriented, the LED fender vents provide highly visible side indication.



The sports-inspired leather wrap gearshift ensures maximum grip when using Active Select to power up or down through the gear range.

The 220 watt Bose® surround sound system employs 10 speakers – including sub-woofers and roof-mounted centre speaker – to surround you with audiophile quality surround sound.



Safety

With stunning on-road performance and all encompassing luxury, goes an unwavering dedication to driver and passenger safety. Inside the Caprice, you are surrounded – literally – by an advanced new multi-layered driver defence system featuring state-of-the-art active and passive safety technology. The former to help prevent collisions; the latter to help prevent injury in the event of a collision.

Active safety

Up to 200 times a second – that's how often the Caprice's active safety systems monitor on-road dynamics. Everything from the vehicle's speed, lateral acceleration and rotation, to the steering wheel angle and brakeforce you apply.

When normal tolerances are exceeded, one or more of the following systems initiate integrated – non-intrusive – counter measures to help ensure you retain maximum control of the vehicle.

Co-ordination of active safety features
Be it from the Electronic Stability Control (ESC) for turning and cornering. The Traction Control System (TCS) that minimises slip when accelerating. Or the Anti-lock Braking System (ABS) with Electronic Brake Assistance (EBA) and Electronic Brakeforce Distribution (EBD) that helps you stop quickly with maximum control. You can expect 360° support from the Caprice's integrated active safety systems.

ESC Electronic Stability Control
ESC constantly compares the vehicle's movements with the steering wheel angle to determine if the vehicle is moving in the direction you intend. If skidding appears imminent, ESC applies brake pressure to individual wheels as appropriate and, if necessary, trims engine power. This dramatically increases turning and cornering safety, especially in 'evasive action' situations.

TCS Traction Control System
Designed to minimise slippage during acceleration, TCS recognises if either rear wheel has insufficient grip and adjusts drive force and brakeforce accordingly. It reduces wheelspin when accelerating on wet and icy roads, and also in 'split' conditions, such as when a vehicle has two wheels on bitumen and two on a gravel verge.

ABS Anti-lock Braking System
If wheel 'lock up' is detected under forceful braking, ABS momentarily reduces brake pressure at the affected wheel. This improves braking efficiency – reducing stopping distances on most surfaces – and helps maintain steering control to ensure the vehicle remains directionally stable.

EBA Electronic Brake Assist
In emergency braking situations, few drivers actually press the brake pedal firmly enough to achieve maximum braking performance. EBA is designed to sense how fast you press the brake pedal in an emergency, and maximise braking pressure to optimise braking performance.

EBD Electronic Brakeforce Distribution
When a vehicle brakes, weight transfers to the front wheels. By regulating the brakeforce applied to each wheel, EBD ensures optimal balance between front and rear brakes, which helps minimise stopping distances.

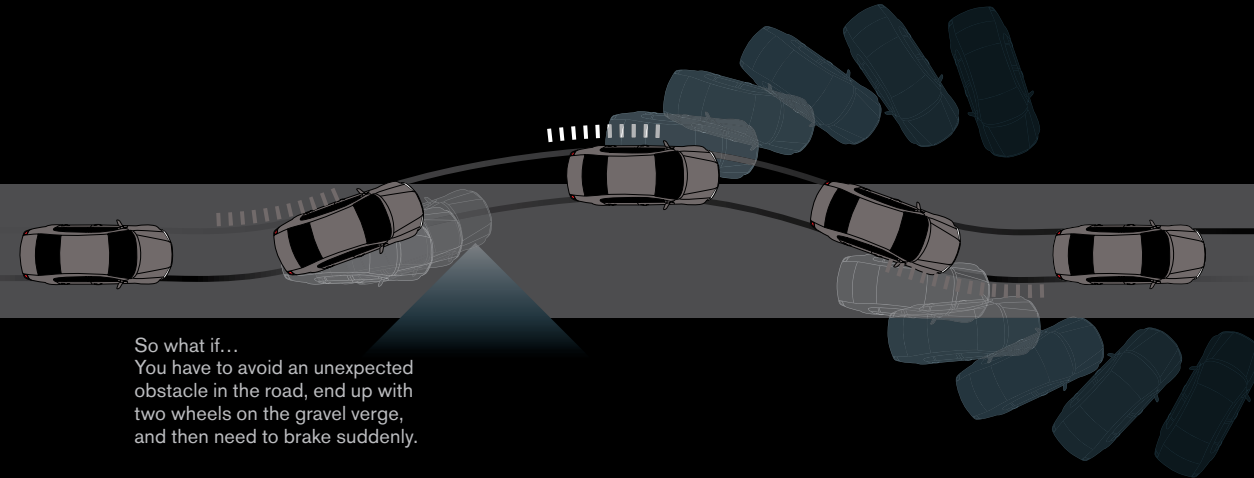
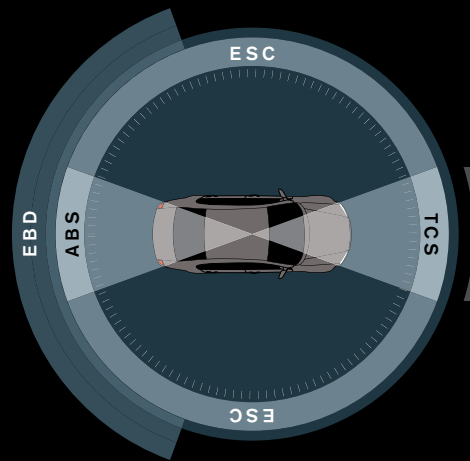

So what if... You have to avoid an unexpected obstacle in the road, end up with two wheels on the gravel verge, and then need to brake suddenly.

ESC brakes the left rear wheel momentarily to avoid understeer.

TCS reduces torque to the left rear wheel to reduce slip.

ESC brakes the right front wheel momentarily and reduces engine power to correct oversteer.

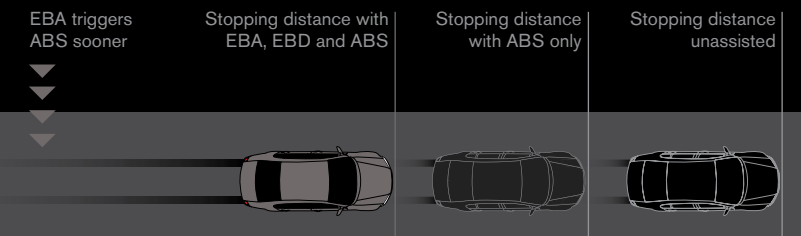

Sensing an emergency stop, EBA initiates maximum brakeforce, ABS maximises brake efficiency and EBD maintains optimal front/rear brake balance.

Stopping distance will depend on road surface and vehicle load conditions

Passive safety

A collision is a contest between impact energy and your vehicle's safety features. You want everything possible on your side.

That's why the Caprice features Holden's Adaptive Occupant Restraint System – which includes dual-stage front airbags for driver and front passenger – as well as multiple load paths to help channel impact energies and a safety cell reinforced with ultra high strength steel.

Most impressive of all, in a frontal crash, the Caprice can automatically initiate and co-ordinate all on-board passive safety measures in an incredible 90 milliseconds (ms) – about the time it takes to snap your fingers.

Co-ordination of passive safety features
To help protect occupants from collision forces, Holden's Adaptive Occupant Restraint System uses forward and side sensors to detect the severity and direction of a collision, triggering the appropriate passive safety measures.

Safety cell, crumple zones and load paths
In frontal and rear collisions, impact energy is absorbed by crumple zones and channelled away from the driver and occupants via multiple load paths.

The Caprice's multiple load path strategy is also integral to side impact protection, as is the vehicle's safety cell. Strategically reinforced with steel seven times stronger than your average steel, it offers protection against passenger safety cell intrusion.

- crash sensors
- 1 driver's front airbag
- 2 passenger's front airbag
- 3 side impact airbags
- 4 curtain airbags
- 5 front crumple zone
- 6 passenger safety cell
- 7 rear crumple zone

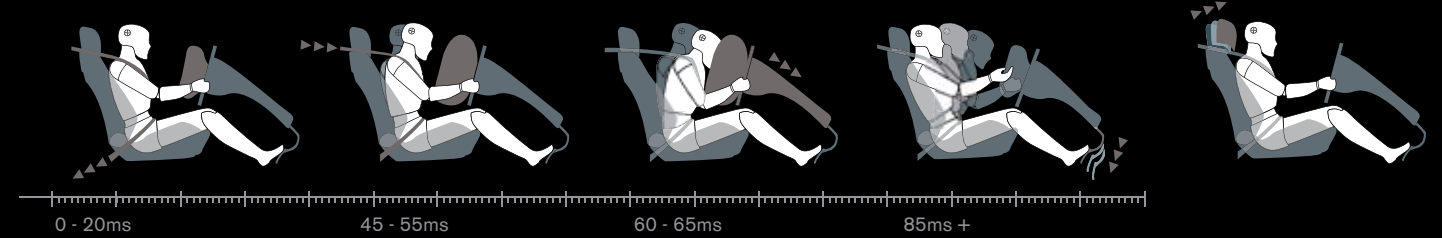
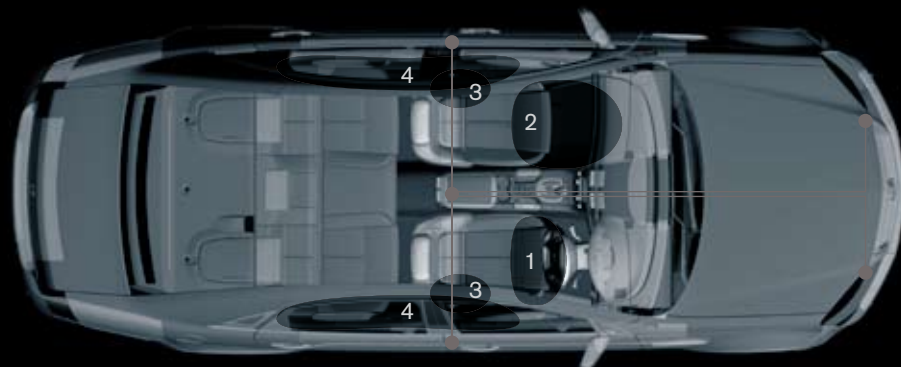

Pyrotechnic seatbelt pretensioners
When an impact of sufficient severity is detected, small explosive charges force the front seatbelt buckles towards the cabin floor. This tightens the seatbelts and helps hold both driver and front passenger firmly against their seats.

Dual-stage front airbags
For maximum protection in certain frontal collisions, the front airbags for driver and front passenger inflate in two stages, according to the impact severity and their respective seat positions.

The 60 litre driver airbag can fully inflate in 45 milliseconds. The front passenger airbag, which is oversized, can inflate to a full 125 litres in just 55 milliseconds.

Curtain and side impact airbags
Side curtain airbags help provide head and upper body protection for front passengers and left and right rear passengers in certain side-on collisions. Side impact airbags help provide additional chest and thorax protection for the driver and front passenger.

Load limiters
The seatbelts incorporate a load limiting system that helps control the level of force applied to an occupant during an accident. This in turn helps reduce seatbelt related injury.

Steering and brake pedal safety
In severe frontal impacts, the steering wheel can collapse bi-directionally and to help prevent leg injury, the brake pedal detaches.

Active front seat head restraints
In rear collisions, active front seat head restraints tilt forward, closing the distance between your head and your seat's headrest, thus helping to reduce the risk of whiplash injury to the neck.

Emergency shutdown
Following a collision where airbags or seatbelt pretensioners have deployed, on-board safety systems will turn off the engine and fuel pump, unlock the doors and turn the hazard and interior lights on, if battery power is available.

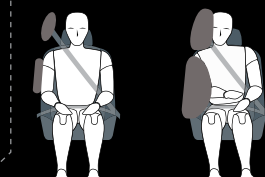

The Caprice is a vehicle driven by innovation. From the futuristic component synchronisation and optional on-board telematics, to the sublime convenience of integrated Bluetooth® connectivity for compatible mobile phones..

Holden Assist telematics

Optional on the Caprice, telematics enables vehicles to send and receive data – and have their position pinpointed at any time – via integrated GSM mobile phone network and global positioning satellite technology.

Owners of telematics-equipped vehicles can take advantage of Holden Assist, a subscription-based interactive security system that provides on-board assistance 24/7.

Holden Assist Ultra

- If an airbag is deployed, the system notifies an operator who will attempt to speak with the driver. If there is no response, emergency services are notified.
- If keys are locked in the vehicle, an operator can validate the owner's identity, then unlock the doors remotely.
- In an emergency, the driver can press the SOS button to speak with an operator, who will locate the vehicle and send emergency services if required.
- If roadside assistance is required, on the press of a button the vehicle is located and assistance despatched.
- If the vehicle battery is low, the system notifies an operator who will attempt to speak with the driver.

GM FleetView

Designed for businesses with on-the-road employees, fleet telematics are designed to increase driver and fleet manager productivity, while encouraging better driver behaviour and greater adherence to occupational health and safety practices. For full details on fleet telematics, call GM Fleet Customer Assistance on 1300 559 696.



Satellite navigation

Full colour mapping satellite navigation is optional on the Caprice. The system provides visual directions and full mapping via the colour LCD screen in the centre console, and audible directions via the vehicle's audio system.



Trip computer

The on-board trip computer is controlled via the scroll wheel and buttons mounted on the steering wheel. Trip data is shown on the electronic driver display. Depending upon your preferences, the information displayed can include:

- trip distance
- average speed
- average fuel usage
- distance to go
- time to go
- range
- odometer reading
- speed
- overspeed warnings (visual and audible)
- underspeed warnings (visual and audible)
- rest reminders every two hours of driving time

It is even possible to track two trips simultaneously, for example a short day trip within a long interstate trip.

Personalisation

The Caprice lets you tailor a range of vehicle functions to your individual liking, including:

- Departure lighting: when locking your vehicle remotely, the headlamps will remain on and turn off automatically after 30, 60, 90 or 180 seconds.
- Approach lighting: when unlocking your vehicle remotely, the headlamps can automatically come on for 60 seconds, or not at all.
- Multi-stage unlocking: when unlocking your vehicle remotely, you can have all four doors unlock at once, or the driver's door on the first press and the remaining doors on the second.

Priority key

The Caprice comes with two priority keys, which store individual driver preferences, such as trip computer display options, climate control settings and radio station presets. Your preferred settings take effect the moment you unlock your car remotely.

Component synchronisation

To deter theft, the audio system, instrument cluster and other key components are electronically synchronised to the vehicle in which they were originally fitted.

Night panel

At night, interior lighting can be dimmed to leave only the speedometer illuminated. Should your attention be required, the relevant instrument lights up. This reduces driver distraction and fatigue, making it perfect for night driving in the country.

HID xenon headlamps

The Caprice's High Intensity Discharge (HID) headlamps each contain a small glass bulb filled with xenon gas. Passing electric current through the gas results in an immensely concentrated and intense beam of light, significantly brighter than traditional halogen lamps of similar size.

Front and Rear Park Assist

The electronic parking sensors on the Caprice provide visual and audible aids when parking the vehicle. Appearing on the centre display, the visual display shows both the direction and distance of nearby objects.



Bluetooth®

Integrated Bluetooth® technology lets you take and make calls, hands-free, at the touch of a button with compatible mobile phones. The controls are conveniently mounted on your steering wheel, the microphone is housed in the roof console, and the call is heard over the audio system – which automatically mutes whatever is playing at the time. No wires. No cradles. No headsets.

Certain mobile phones may not be compatible with the vehicle's Bluetooth® system. Visit holden.com.au to determine your phone's compatibility



MP3 player connectivity

The audio system includes an auxiliary input jack for external music sources, such as MP3 players.



Tri-screen DVD Player

A remote control operated, tri-screen DVD system with stereo headphones is standard on the Caprice. Integrated into the rear front head rests, the system plays DVDs for rear passengers via the dual high-resolution LCD screens. The front centre console LCD screen also displays DVDs when the vehicle is stationary.

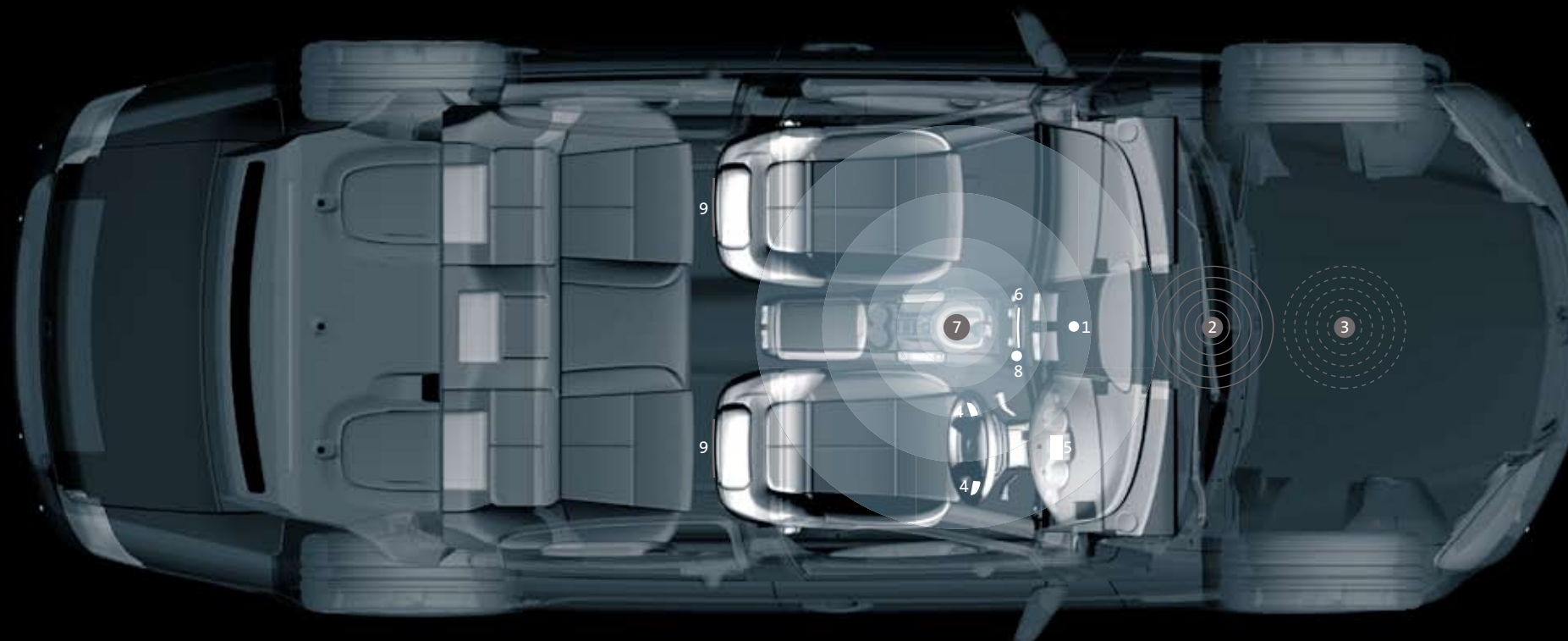

Location of features when fitted

- 1 Holden Assist telematics SOS button located on rear vision mirror
- 2 Telematics GSM network transmitter
- 3 Satellite navigation GPS transmitter
- 4 Steering wheel mounted scroll wheel and buttons for controlling satellite navigation, trip computer, audio system, personalising settings and hands-free phone calls using Bluetooth®
- 5 Centre driver display for messages such as satellite navigation directions, trip computer data and more
- 6 Centre console screen displays full audio system data and full-colour mapping when satellite navigation is fitted
- 7 Microphone for telematics communications and hands-free Bluetooth® mobile phone calls
- 8 Audio system auxiliary input jack for connecting MP3 players
- 9 Integrated DVD player and screen

Power

Generation 4 Alloy V8

Brutal, road dominating power. Supremely responsive performance. Endless satisfaction. When you go with the 6.0 litre Generation 4 Alloy V8 engine, you never look back. Delivering an awesome 260kW* of power and 517Nm* of torque, it features:

- Active Fuel Management (AFM), which can seamlessly shut down four cylinders according to engine load and acceleration requirements, thus reducing petrol usage.
- Electronic Throttle Control for immediate response and maximum performance
- Lightweight alloy construction, enabling a more supple front suspension and smoother ride
- A one piece induction system for smooth airflow and superior breathing

6-speed automatic transmission with Active Select

Marshalling that menacing power into an exceptionally refined driving experience is a perfectly mated 6-speed automatic transmission with Active Select. Delivering improved acceleration this slick, world-class transmission enables one touch switching from automatic to manual shifting, for those times when you feel like true 'hands-on' driving.



Alloytec V6

The Caprice can also be fitted with the 3.6 litre High Output Alloytec V6 engine. One of the most advanced production engines ever manufactured in Australia, it generates a potent 195kW* of power and 340Nm* of torque, with features that include:

- Alloy construction for power and strength
- Variable intake manifold for outstanding performance and reliability
- Double overhead camshaft for improved performance
- Four valves per cylinder to help the engine breathe better for greater performance
- Continuously variable valve timing for enhanced performance and responsiveness

5-speed automatic transmission with Active Select

Teamed with the optional High Output Alloytec V6 engine, the 5-speed automatic transmission with Active Select combines outstanding driveability and response with smooth, crisp – almost seamless – gear changes. Plus, the option to shift manually anytime you choose.

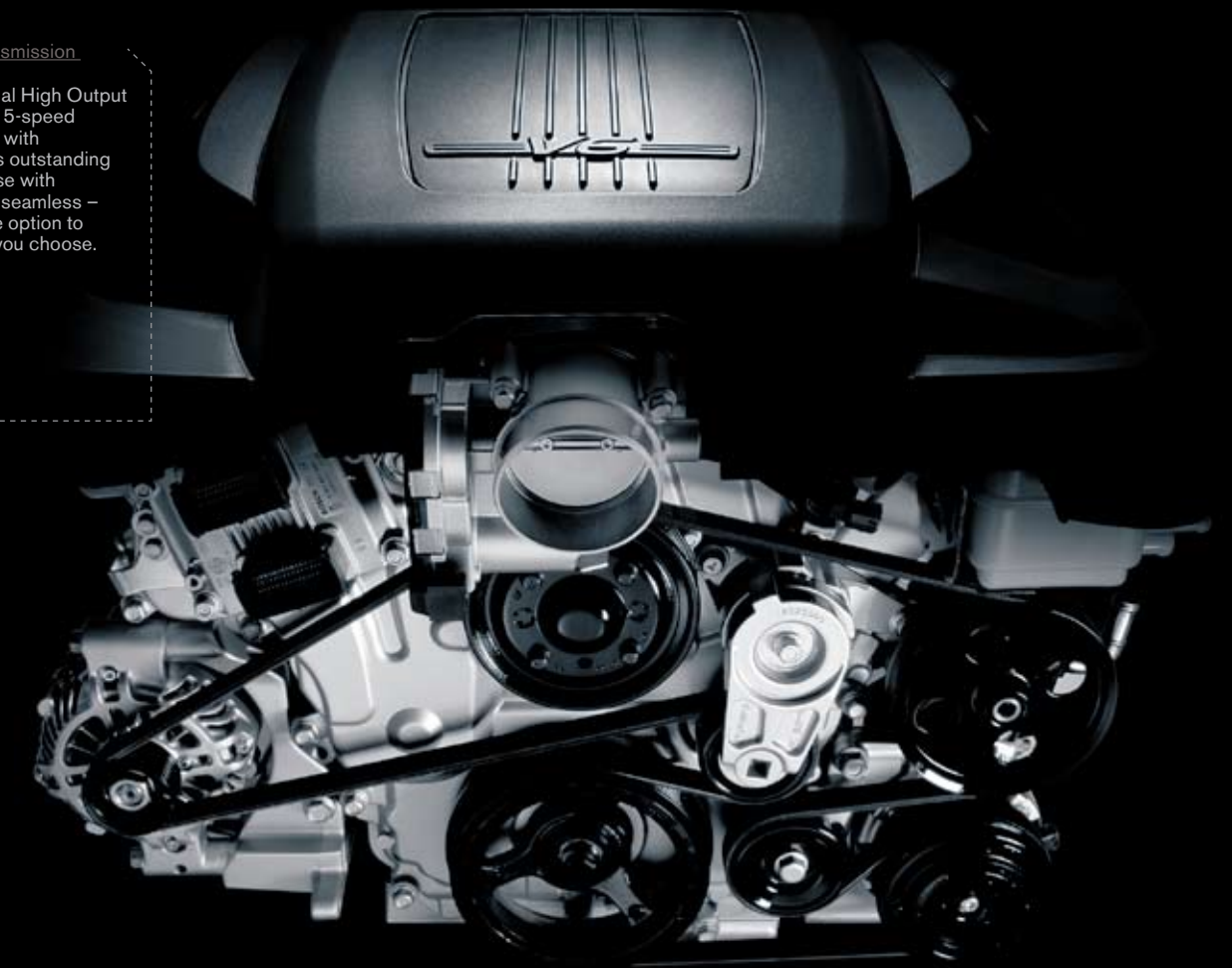

features

engine	exterior/interior	exterior/interior (continued)	safety/security
engine and transmission	wheels	entertainment	occupant safety
260kW,*# 6.0 litre Generation 4 Alloy V8 engine with Active Fuel Management (AFM) and 6-speed automatic transmission with Active Select	18" x 8" alloy wheels. 245/45 R18 96V tyres (5)	Bose® premium audio system featuring ten speakers, including sub-woofers. Total 220 watts	Dual-stage front airbags for driver and front passenger, side impact airbags for driver and front passenger, and side curtain airbags
195kW,# 3.6 litre High Output Alloytec V6 engine with 5-speed automatic transmission with Active Select	Full size alloy spare wheel	6-disc CD audio system with MP3 compatibility and auxiliary input jack	Front seatbelts with load limiters and pyrotechnic pretensioners
Limited Slip Differential	exterior	Speed dependent volume control	Front seatbelt height adjustable
control and handling	Front fog lamps	DVD player with dual LCD screens. Remote control. Front LCD screen also plays DVD when vehicle is stationary	Rear seat child restraint anchor points (3)
Linear Control Suspension	Bi-Xenon headlamps	Headsets for rear passengers, two pairs	Active front seat head restraints to help reduce risk of whiplash injury in a collision from behind
Electronic Stability Control (ESC) incorporating:	LED tail lamps	Multi-mode function to allow headset choice of radio, CD or DVD	security
Anti-lock Braking System (ABS)	Heated, power exterior mirrors with 'puddle' lamps and position memory	Rear overhead console remote control of audio and DVD functions	Remote control priority key:
Electronic Brakeforce Distribution (EBD)	Dual exhaust outlets (V6 only)	Rear audio visual auxiliary jack	Operates central locking
Electronic Brake Assist (EBA)	Quad exhaust outlets (V8 only)	Diversity antenna: FM	Operates interior lighting. Time delay on entry. Automatic illumination when engine turned off
Traction Control System (TCS)	Chrome finish body side mouldings	seating	Operates exterior lamps
	Chrome highlight exterior door handles	'Soft-touch' leather appointed seats with leather door trim inserts	Enables/disables alarm system
	driver	10-way electric adjustment of front seats: Slide. Cushion tilt. Height. Recline. Lumbar	Unlocks boot
	Steering wheel height and reach adjust	Driver's seat memory for 3 driver positions	Disables remote boot release button in glovebox (when locking)
	Leather wrap steering wheel	cabin comfort	Horn sounds if front door is ajar when remote locking
	Leather wrap gear selector	Tri-zone electronic climate control: driver, front passenger and rear	Sound system and DVD player operate only in original vehicle
	Multifunction steering wheel, featuring illuminated controls for:	6.5" Multifunction colour LCD screen. Displays stereo and climate control information. DVD player and satellite navigation compatible (where fitted)	Holden Assist telematics
	Sound system	Power windows. Driver and front passenger windows express up and down	
	Trip computer	Electric tilt and slide sunroof	
	Bluetooth® for compatible mobile phones	Front centre armrest with leather trim	
	Satellite navigation (where fitted)	Rear seat centre armrest with storage compartment	
	Multifunction driver display, featuring:	Vanity mirror, driver and front passenger. Illuminated with cover	
	Trip computer information	Sunglasses holder (except where sunroof fitted)	
	Sound system information	Chrome finish interior door handles	
	Priority keys. Store settings for:	Passenger overhead assist handles; rear with coat hooks	
	Climate control	Front and rear reading lamps	
	Radio presets	Door entry lamps	
	Trip computer	storage and cargo	
	Speed warning	Twin cup holders in front centre console and rear seat	
	Headlamp and interior lighting time delay options	Centre console storage compartment	
	Driver's seat adjustment and exterior mirror position	Auxiliary power socket in console and boot	
	Cruise control	Fold down rear seat centre 'ski' hatch for long loads	
	Front and Rear Park Assist	Luggage net (adjustable) in boot to keep small items in place	
	Electro-chromatic interior rear vision mirror reduces headlamp glare automatically		
	Passenger side exterior mirror dips when reverse gear selected to show low-level hazards		
	Rain sensing wipers		
	Automatic headlamp mode. Switches on at twilight or low light. Manual override		
	Tyre pressure monitor		
	Sound system able to accommodate mobile phone kit. Auto mute when phone is in use		
	Bluetooth® for compatible mobile phones		
	Satellite navigation. Full colour mapping		

Maximum figures as per ECE regulations
*Figure quoted using 98 RON (PULP)

● standard
○ optional

technical specifications

		195kW, 3.6 litre High Output Alloytec V6 engine	260kW,* 6.0 litre Generation 4 Alloy V8 engine					Caprice
Engine		3.6L 60-degree Double Overhead Cam V6 with 4 valves per cylinder. Twin knock control sensors with individual cylinder adaptive control. On-board diagnostics	6.0L 90-degree OHV V8. Cross flow cylinder heads. Twin knock control sensors. On-board diagnostics. Active Fuel Management (AFM)	Recommended petrol octane rating	91 RON ULP Note that using 95 RON (PULP) or higher may result in improved engine performance and efficiency			
		Continuously variable camshaft phasing for inlet and exhaust cams. Variable Intake Manifold (VIM)	Central plenum with individual symmetrical runners	Petrol tank capacity (L)	73			
Capacity (cc)		3564	5967	Brakes	Four wheel disc. Ventilated discs – front and rear. Twin piston alloy front caliper, single piston alloy rear caliper			
Compression ratio (:1)		10.2	10.4	Electronic Stability Control (ESC)	Incorporating: Anti-lock Braking System (ABS), Electronic Brakeforce Distribution (EBD), Electronic Brake Assist (EBA), Traction Control System (TCS)			
Power (ECE, kW)*		195kW @ 6500rpm	260kW* @ 5700rpm	Suspension	Front: Direct acting stabiliser bar. Coil springs Rear: Multi-Link Independent Rear Suspension (IRS) Semi-trailing arm. Mini-block coil springs. Stabiliser bar			
Torque (ECE, Nm)*		340Nm @ 2600rpm	517Nm* @ 4400rpm	Sports luxury suspension	Front: Firmer spring rate. Reduced ride height Rear: Firmer spring rate. Gas pressure dampers			
Exhaust system – stainless steel		Dual exhaust outlets	Quad exhaust outlets	Steering	Variable ratio rack and pinion			
Engine cooling		Electric Cooling Fans	Electric Cooling Fans	Track (mm)	Front: 1592 Rear: 1608			
Gear ratios		5sp Auto	6sp Auto	Turn circle (kerb to kerb, m)	11.6			
	1st	3.42	4.03	Wheelbase (mm)	3009			
	2nd	2.21	2.36	Exterior design dimensions (mm)	Length	Width (excluding mirrors)	Height	Ground clearance
	3rd	1.60	1.53		5160	1899	1480	110
	4th	1.00	1.15	Interior design dimensions (mm)	Leg	Shoulder	Head	Hip
	5th	0.75	0.85		1071	1501	985	1439
	6th	–	0.67		1098	1500	965	1472
	Final drive ratio	2.92	2.92	Boot volume (L)	535			
		#Maximum figures as per ECE regulations		Towing (kg)	Maximum towing: 2100. Holden approved 1200, 1600 and 2100 towing equipment is available. See your Holden Dealer for details.			
		*Figure quoted using 98 RON (PULP)		Weight	Visit holden.com.au for further information			
				Service	The complimentary inspection is due at 3,000km or 3 months (whichever occurs first). The first service is due at 15,000km or 12 months (whichever occurs first) and then every 15,000km or 12 months (whichever occurs first) since the last service. Additional services may be required under certain driving conditions such as when towing (refer to owner's handbook).			

visit holden.com.au for further colour and trim information

exterior colours^v



Heron White



Nitrate Metallic*



Sandstorm Metallic*



Cobra Metallic*



Provence Metallic*



Karma Metallic*



Red Passion Metallic*



Evoke Metallic*



Phantom Metallic*

leather trim (available with all exterior colours)

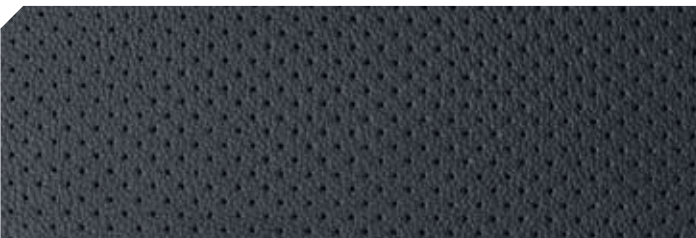

Onyx

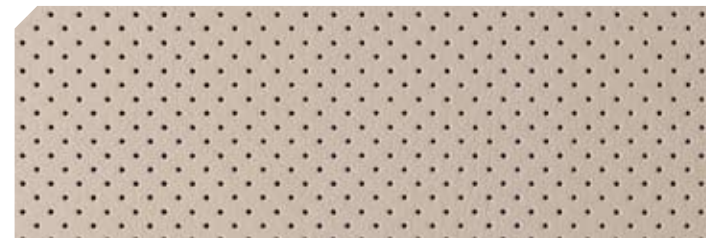

Light Urban

*Metallic paints are available at an additional cost and certain colours may not be available from time to time. Variations between colours shown and actual paint colours/interior trim colours may occur due to the brochure printing process. Actual vehicle colours may appear different under certain light conditions. Customers are encouraged to contact their Holden Dealer for current colour availability.

easy purchase options

Finance

SmartChoices, provided by GMAC Financial Services, is an array of automotive finance products designed to help the dream of driving a new Holden become a reality. Just select the product, term and payment structure that best suits your lifestyle, your Holden Dealer can provide more information.¹

Insurance

Holden Insurance offers a range of competitively priced insurance products, providing tailor-made protection, at the level of cover you need. For more information, call the Holden Insurance hotline on 1300 784 026.¹

Holden Leasing

Businesses of all sizes are now accessing vehicle leasing options with Holden Leasing. We operate nationally through the Holden Dealer Network and our dedicated service and support team. Our people are responsive professionals who understand your business and what it means to deliver total fleet management solutions. To find out how Holden Leasing can help you, call us on 1800 022 077.

GM Holden Card

The GM Holden Card can assist you to get into a new Holden sooner. 10% of your credit card purchases go towards a Rebate of up to \$3,000 on your new Holden² (depending on model). That's up to \$1 saving on your new Holden for every \$10 spent. There are a range of extra features including up to 45 days interest free³ on credit card purchases and a competitive interest rate. Apply⁴ online at www.holden.com.au/mastercard, or call the GM Holden Card 24hr helpline on 131 200.

ownership benefits

Holden Service

With one of the largest Service Networks in the country, Holden Dealers can supply an enviable level of customer care. Only Holden Dealership technicians have access to regular Holden factory training and equipment.

The Holden Luxury Edge

One of the extras you get from owning a new Caprice is extra peace of mind. With the Holden Luxury Edge, the first three handbook services are at no extra charge⁵ as long as they fall within the first 12 months from date of first registration. For complete terms and conditions, just ask your Dealer.

Holden New Vehicle Warranty

Every new Holden comes with a New Vehicle Warranty, covering your Holden for 3 years⁵ or 100,000 kilometres, whichever comes first. This factory backed warranty covers items including the engine, transmission, interior and exterior components. Refer to your Owner's handbook or see your Holden Dealer for full terms, conditions and exclusions.

Holden PLUS Extended Factory Warranty

Holden also offers Holden PLUS Extended Factory Warranty. Holden PLUS is a complete extension of your New Vehicle Warranty, giving you peace of mind because your car is factory backed for up to 3 additional years. The very same items covered under the New Vehicle Warranty will continue to be covered under Holden PLUS, without exclusion. The Holden PLUS Extended Factory Warranty can be purchased through your local Holden Dealer at the same time as your Holden vehicle purchase. See your Holden Dealer or call 1300 308 062 for full terms and conditions.

24 Hour Roadside Assistance

Provided for the first year of your new Holden's life⁶. Holden Roadside Assistance is one of Australia's most comprehensive assistance packages with over 3,000 Roadside Assistance patrols nationwide⁶. There to help with even the smallest service, the toll-free Roadside Assistance hotline is always open, 1800 817 100.

For more information contact

Holden Customer Assistance on 1800 033 349 Monday to Friday 8am to 7pm or Saturday 9am to 1pm EST or visit www.holden.com.au

¹ Subject to approval. ² The maximum GM Holden Card 'Core Rebate' (plus additional 'Bonus Rebate' accumulated via the Partner Program) applicable for each vehicle, accrued over a maximum of five years may be applied per eligible vehicle purchased. For the maximum Rebate applicable for each vehicle refer to the 'Maximum Rebate Levels' table at www.westpac.com.au/holden. Vehicle sales for which a fleet allowance is paid are not eligible for GM Holden Card Rebate. Earning and redemption of Rebate towards a new Holden is subject to the GM Holden Card Rebate Program Rules. ³ The interest-free period applies where the card account is fully paid by the due date each month. ⁴ GM Holden Card is approved by Westpac. Applications are subject to Westpac's normal lending criteria. ⁵ From date of first registration. ⁶ In remote or sparsely populated areas you may experience delay in obtaining Roadside Assistance. Refer to the Customer Care brochure in your glovebox for full terms and conditions of this service.