

easy purchase options	ownership benefits
Insurance	Holden Service
Holden Insurance offers a range of competitively priced insurance products, providing tailor-made protection, at the level of cover you need. For more information, call the Holden Insurance hotline on 1300 784 026. ¹	With one of the largest Service Networks in the country, Holden Dealers can supply an enviable level of customer care. Only Holden Dealership technicians have access to regular Holden factory training and equipment.
Holden Leasing	Holden New Vehicle Warranty
Businesses of all sizes are now accessing vehicle leasing options with Holden Leasing. We operate nationally through the Holden Dealer Network and our dedicated service and support team. Our people are responsive professionals who understand your business and what it means to deliver total fleet management solutions. To find out how Holden Leasing can help you, call us on 1800 022 077.	Every new Holden comes with a New Vehicle Warranty, covering your Holden for 3 years ² or 100,000 kilometres, whichever comes first. This factory backed warranty covers items including the engine, transmission, interior and exterior components. Refer to your Owner's handbook or see your Holden Dealer for full terms, conditions and exclusions.
	Holden PLUS Extended Factory Warranty
	Holden also offers Holden PLUS Extended Factory Warranty. Holden PLUS is a complete extension of your New Vehicle Warranty, giving you peace of mind because your car is factory backed for up to 3 additional years. The very same items covered under the New Vehicle Warranty will continue to be covered under Holden PLUS, without exclusion. The Holden PLUS Extended Factory Warranty can be purchased through your local Holden Dealer at the same time as your Holden vehicle purchase. See your Holden Dealer or call 1300 308 062 for full terms and conditions.
	24 Hour Roadside Assistance
	Provided for the first year of your new Holden's life. ² Holden Roadside Assistance is one of Australia's most comprehensive assistance packages with over 3,000 Roadside Assistance patrols nationwide. ³ There to help with even the smallest service, the toll-free Roadside Assistance hotline is always open, 1800 817 100.
	For more information contact Holden Customer Assistance on 1800 033 349 Monday to Friday 8am to 7pm or Saturday 9am to 1pm EST or visit www.holden.com.au



Bluetooth® is a registered trademark and logo of Bluetooth SIG, Inc.
A word about this catalogue. We have tried to make this catalogue as comprehensive and factual as possible. However, since the time of printing some of the information you'll find here may have been updated. Also, some of the equipment shown or described through this catalogue may have been changed and / or is available at extra cost. Further, GM Holden Ltd ABN 84 006 893 232, reserves the right to make changes at any time without notice, in prices, colours, materials, equipment and models. Your Holden Dealer has details, and before ordering, you should ask them to bring you up to date. No Holden Dealer or other person is authorised or permitted to give or make any statement, assertion or undertaking in relation to the quality, performance characteristics, descriptions or fitness for any purpose of any Holden product which is at variance with any written statement, assertion or undertaking on any of these subjects given or made by GM Holden Ltd in its published sales literature, and GM Holden Ltd does not accept any liability for any such unauthorised action. GM Holden Ltd has authorised Dealers in many parts of Australia for the sale of service parts and the provision of service to owners of Holden's products. Every endeavour is made to ensure that such Dealers carry adequate stocks of service parts, but GM Holden Ltd doesn't make any promise other than that contained in the New Vehicle Warranty given by GM Holden Ltd that such parts or service facilities will be available at any specific location or at any particular time. Express warranties offered for Holden products are subject to the conditions set out in all vehicle handbooks. Details also available from GM Holden Ltd on request. Copyright GM Holden Ltd, July 2010. emerystudio EPICA0610 AD12875

¹ Subject to approval. ² From date of first registration. ³ In remote or sparsely populated areas you may experience delay in obtaining Roadside Assistance. Refer to the Customer Care brochure in your glovebox for full terms and conditions of this service.

it ticks every box

It is a vehicle completely in tune with the times. One that puts a tick in every box worth ticking. That understands what really matters, and delivers it with style and sophistication.

The Holden Epica.

Because you want to cut fuel usage – and CO2 emissions[^] – it's available with an advanced 4-cylinder turbocharged diesel engine. One that supplies smooth, free-flowing power and can go more kilometres between fills.

So that you can travel those kilometres with total confidence, it's also equipped with a full complement of safety systems, including Electronic Stability Control, plus front, side impact and side curtain airbags.

And because driving should never be a chore, both Epica models offer features and technology you would expect only on vehicles far more expensive. Everything from automatic headlamps and six-speed automatic transmission with Active Select, to steering wheel mounted audio controls and a 60/40 split fold rear seat.

Most important of all, is the feature no other manufacturer can offer: the Holden lion. A symbol of quality workmanship, service you can trust, support you can rely on and six decades of delivering cars that simply go better, it's your assurance that truly great driving awaits.

Everything you do want, nothing that you don't. In today's mid-size market, the smart money is on Epica.

[^]Based on CO2 emissions of 199 grams per km for Epica diesel and 229 grams per km for Epica petrol

automatic headlamps



front, side impact and side curtain airbags



Electronic Stability Control



steering wheel mounted audio and cruise controls

Holden through and through

Compelling on the open road. A joy in city traffic. Epica's state-of-the-art Common Rail diesel supplies potent turbocharged performance with torque to spare from low revs through to high.

Overtaking at speed. Climbing a hill. Accelerating through a bend. Merging or lane changing. The super responsive turbo diesel makes every driving situation that much easier.

Vehicle dynamics are just as impressive. A Holden through and through, Epica's steering is precise, and its ride solid, centred and always composed. Comfort and driving stability are maximised by high mounted rear multi-link suspension and gas shock absorbers. While MacPherson Strut front suspension with internal rebound springs reduce body roll and ensure excellent handling through corners and on uneven roads.

Opt for Epica's advanced 2.5 litre six-cylinder in-line petrol engine, and you can expect the same exceptional driving experience. With silky smooth power delivery the Epica delivers a first class ride all the way.

rear multi-link suspension



six-speed automatic transmission with Active Select



advanced 4-cylinder turbocharged diesel engine



8-way adjustable driver's seat

tilt and telescopic steering

generous head room, elbow room and leg room

intelligent design

Expect to feel very much at home inside the Holden Epica. Not just because of the elegance and luxury of its contemporary interior, but because its intelligent design makes your every journey easier, safer and more rewarding.

To ensure you enjoy the absolute optimum position behind the wheel, the steering column adjusts four ways, and your deep cushioned driver's seat – which includes lumbar support – eight ways.

Instrumentation, controls and switchgear also display exacting attention to detail. From the primary instrument cluster to the steering wheel mounted, Bluetooth® audio and cruise controls, everything is designed and positioned for intuitive operation, leaving you to focus your attention on the road ahead.

Standard equipment levels are high. The Epica CDX includes air conditioning, cruise control, Bluetooth® for compatible mobile phones, a 6-speaker MP3 compatible in-dash CD player with auxiliary input, power windows, power mirrors, four cup holders and 60/40 split fold rear seat. With the CDXi adding climate control, electronic driver display, a premium 6-disc audio system and more.

The big features you want. The little touches you'll love. Epica includes them all.

Cabin space is also plentiful. With more than generous head room, leg room and elbow room, Epica has more than enough room for five adults to relax in comfort. And more room still for their belongings, in its numerous integrated storage compartments and cavernous 480 litre boot.



safety

Because nothing is more important than your safety, Holden Epica protects your every driving moment with an intelligent multi-layered driver defence system that surrounds you – literally – with advanced active and passive safety features. The former to help prevent collisions; the latter to help prevent injury should a collision be unavoidable.

Active safety

To help prevent collisions, every Epica monitors on-road dynamics every moment you're driving. Everything from the vehicle's speed, lateral acceleration and rotation, to the steering wheel angle and brake force you apply. When normal tolerances are exceeded, one or more active safety systems instantly initiate non-intrusive counter measures to help ensure you retain maximum control of the vehicle.

Co-ordination of active safety features
Tightly integrated and fully co-ordinated, Epica's active safety systems provide you with 360° support:

- The Electronic Stability Control (ESC) helps safeguard you during turning and cornering
- The Traction Control System (TCS) helps minimise wheel slip when accelerating
- The Anti-lock Braking System (ABS) and Electronic Brakeforce Distribution (EBD) help you stop quickly with maximum control

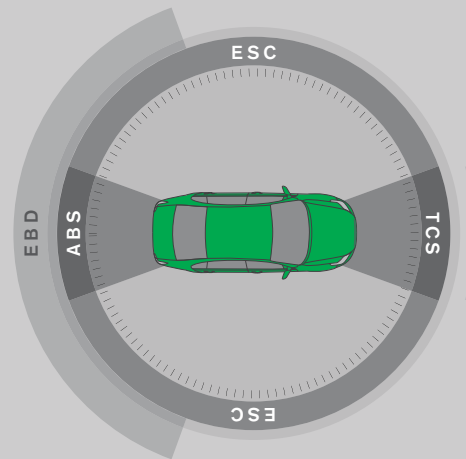

ESC Electronic Stability Control
ESC constantly compares the vehicle's movements with the steering wheel angle to determine if the vehicle is moving in the direction you intend. If skidding appears imminent, ESC applies brake pressure to individual wheels as appropriate and, if necessary, trims engine power. This dramatically increases turning and cornering safety, especially in 'evasive action' situations.

TCS Traction Control System
TCS is designed to minimise slippage during acceleration by recognising if either front wheel has insufficient grip, and adjusting driveforce and brakeforce accordingly. It produces greater vehicle stability on wet and icy roads, and also in 'split' conditions, such as when a vehicle has two wheels on bitumen and two on a gravel verge.

ABS Anti-lock Braking System
If wheel 'lock up' is detected under forceful braking, ABS momentarily reduces brake pressure at the affected wheel(s). This improves braking efficiency – reducing stopping distances on most surfaces – and helps the vehicle remain steerable and directionally stable.

EBD Electronic Brakeforce Distribution
When a vehicle brakes, weight transfers to the front wheels. By regulating the brakeforce applied to each wheel, EBD helps ensure optimal balance between front and rear brakes, which helps minimise stopping distances.

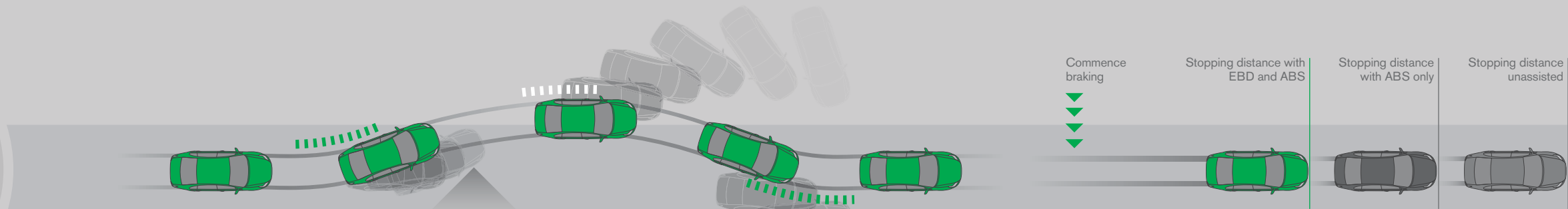

So what if...
You have to avoid an unexpected obstacle in the road, end up with two wheels on the gravel verge, and then need to brake suddenly:

ESC brakes the left rear wheel momentarily to avoid understeer

TCS reduces torque to the left front wheel to reduce slip

ESC brakes the right front wheel momentarily and reduces engine power to correct oversteer

ABS maximises brake efficiency and EBD automatically adjusts the front/rear brake balance based on the number of passengers, cargo load and road condition

stopping distance will depend on road surface and vehicle load conditions

Passive safety

In an accident, it's the impact energy of the collision versus your vehicle's safety systems. You want everything possible on your side. That's why every Epica is equipped with an array of sophisticated occupant protection systems, including:

- front and side impact airbags for the driver and front passenger
- side curtain airbags
- a three-stage bumper design and four-way impact distribution strategy to help absorb and channel collision energies away from the vehicle's reinforced safety cell.

Co-ordination of passive safety features

In a collision, the Epica uses forward and side sensors to detect the direction and severity of impact.

In response to certain collisions, the vehicle can co-ordinate and deploy the appropriate safety measures in just a few thousandths of a second – about the same time it takes to snap your fingers.

Safety cell, crumple zones and impact distribution

In frontal and rear collisions, impact energy is absorbed by the vehicle's bumper bar and crumple zones, then channelled away from the driver and occupants via four longitudinal distribution paths. For added safety, the fuel tank is positioned in front of the rear axle.

Collision energy from a side impact is channelled away by the vehicle's high tensile reinforced A, B and C pillars, in conjunction with floor and roof mounted cross members. The driver and front passenger are further protected via impact beams engineered into Epica's front doors, and the cross bars located in each front seat.

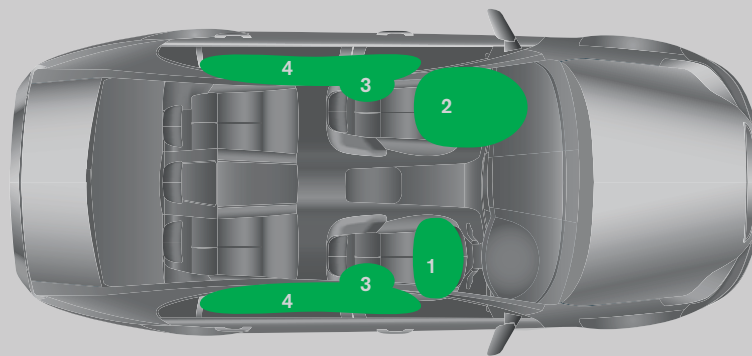

- 1 driver's front airbag
- 2 passenger's front airbag
- 3 side impact airbags
- 4 curtain airbags
- 5 front crumple zone
- 6 passenger safety cell, which includes reinforced A, B and C pillars
- 7 rear crumple zone

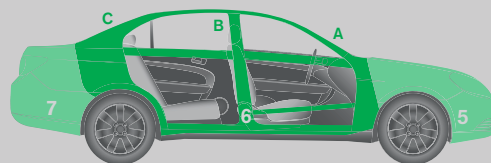

Height adjustable lap/sash front seatbelts

To maximise seatbelt effectiveness, the driver and front passenger can each lower or raise their seatbelt sash to ensure it sits correctly in the point between their neck and the point of their shoulder.



Pyrotechnic seatbelt pretensioners

When an impact of sufficient severity is detected, small explosive charges force the front seatbelt buckles towards the cabin floor. This tightens the seatbelts and helps hold both driver and front passenger firmly against their seats.

Front airbags

For maximum protection in certain frontal collisions, Epica will deploy front airbags for the driver and passenger. The 50-litre driver airbag can fully inflate in 50 milliseconds. While the front passenger airbag can inflate to a full 120 litres in just 54 milliseconds. If there is no front seat passenger, Epica CDXi deploys only the driver's side airbag.

Curtain and side impact airbags

Standard across the range, side curtain airbags provide head and upper body protection for front seat occupants and left and right rear passengers. Side impact airbags provide additional chest and thorax protection for the driver and front passenger.

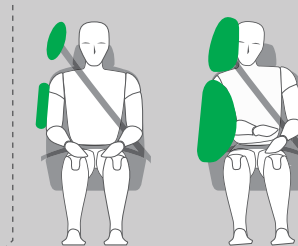

Load limiters

Following front airbag deployment, load limiters unspool the front seat belts incrementally to minimise the risk of seatbelt related injury.

Collapsible steering wheel

To help prevent driver injury in a severe frontal impact, Epica's height adjustable steering wheel can collapse to absorb collision energy. Further protection to the driver is provided by an energy-absorbing knee guard.

Diagrams for illustration purposes only

CDX

Turbocharged 4-cylinder diesel power or smooth in-line petrol six. Executive level technology and equipment. Comprehensive safety systems. All in the one incredibly stylish, extremely spacious mid-size sedan. And all for incredible value from a manufacturer you know and trust. The uncompromising Holden Epica CDX sets the standard in affordable mid-size motoring. For the astute buyer, there is no smarter choice.

Standard features include:

- 115kW/237Nm* 2.5 litre in-line 6-cylinder engine or optional 110kW/320Nm* 2.0 litre 4-cylinder turbocharged common rail diesel engine (CDTi)
- 6-speed automatic transmission with Active Select
- Electronic Stability Control (ESC), incorporating: Traction Control System (TCS)
- Anti-lock Braking System (ABS)
- Electronic Brakeforce Distribution (EBD)
- 6 airbags, including:
 - Front airbags for driver and front passenger,
 - side impact airbags for driver and front passenger and side curtain airbags
- Sensor deactivated passenger airbag
- 16" alloy wheels (4)
- Body coloured pullout door handles and power side mirrors with integrated indicators
- Projector headlamps
- 8-way adjustable driver's seat with lumbar support
- 4-way adjustable steering column
- Air conditioning with air filter
- Bluetooth® for compatible mobile phones†
- 6-speaker audio system with MP3 compatible in-dash CD, radio and auxiliary input jack
- Cruise control with steering wheel mounted switches
- Power windows – front and rear
- Four cup holders
- Automatic headlamp mode: switches headlamps on at twilight or low light
- Door-mounted courtesy lamps
- 60/40 split fold rear seats
- Large capacity boot (480 litres)
- Remote keyless entry for doors and boot
- Flip keys (2)
- Engine immobiliser
- Anti-theft alarm

CDX in Desert Sand (Prestige Paint)

Automatic headlamps In low light conditions Epica automatically activates headlamps as appropriate, to help ensure both your vehicle and the road remain clearly visible.



6-speed automatic transmission with Active Select Engage Active Select and get hands on with gear shifting, or simply select drive and sit back and enjoy the ride. Either way, this precisely calibrated six-speed transmission teams superbly with Epica's turbo diesel and petrol to deliver a smooth ride all the way.



Six airbags Drive with total confidence, safe in the knowledge that every Epica is equipped with front, side impact and side curtain airbags to help protect you and your passengers in the event of certain collisions.



Bluetooth® connectivity† Integrated Bluetooth® technology lets you receive calls, hands-free at the touch of a button with compatible mobile phones. The controls are conveniently mounted on your steering wheel, the call is then heard through the audio system.



steering wheel mounted audio and cruise controls +

curtain airbags +

16" alloy wheels +

Electronic Stability Control (ESC) +



* Maximum figures as per ECE regulations
† Certain mobile phones may not be compatible with vehicle's Bluetooth® system. Check with your phone dealer to determine your phones compatibility

CDXi

Take the next step and experience a leap forward in style and features, with your choice of turbo diesel or silky smooth petrol six. Complete with dynamic sports body kit, six-speed auto transmission with Active Select, rear parking sensors, climate control air conditioning and premium 6-disc in-dash audio system, the superb Epica CDXi looks, feels and drives like a vehicle many times more expensive.

Standard features include:

- 115kW/237Nm* 2.5 litre in-line 6-cylinder engine or optional 110kW/320Nm* 2.0 litre 4-cylinder turbocharged common rail diesel engine (CDTi)
- 6-speed automatic transmission with Active Select
- Electronic Stability Control (ESC), incorporating: Anti-lock Braking System (ABS)
- Electronic Brakeforce Distribution (EBD)
- Traction Control System (TCS)
- 6 airbags, including:
 - Front airbags for driver and front passenger,
 - side impact airbags for driver and front passenger and side curtain airbags
- Projector headlamps
- 8-way adjustable driver's seat with lumbar support
- 4-way adjustable steering column
- Bluetooth® for compatible mobile phones*
- Cruise control with steering wheel mounted switches
- Power side mirrors with integrated indicators
- Power windows – front and rear
- Four cup holders
- Automatic headlamp mode: switches headlamps on at twilight or low light
- Door-mounted courtesy lamps
- 60/40 split fold rear seats
- Large capacity boot (480 litres)
- Flip keys (2)
- Engine immobiliser
- Anti-theft alarm

Specific feature highlights:

- 17" alloy wheels (4)
- Sports body kit
- Front fog lamps
- Rear parking sensors
- Silver surround body coloured pullout door handles
- Premium radio/MP3 compatible 6-disc CD player with auxiliary input and 8-speakers
- Illuminated vanity mirrors
- Climate control air conditioning
- Leather wrap steering wheel and gear shifter
- Electronic driver information display, featuring 4 mode trip computer, climate control functions and compass
- Sensor deactivated passenger airbag
- Optional leather appointed seats

CDXi in Nitrate (Prestige Paint)

Electronic driver information display

Mounted high on the centre console for 'at a glance' convenience, the driver information display provides you with real time information on a range of vehicle functions.



Leather wrap steering wheel and gear shifter

More than just a stylish, sports-inspired enhancement, the leather wrapped steering wheel and gear shifter are more tactile and easier to grip while driving.



Rear parking sensors

Using audible warnings to indicate the proximity of potential obstacles, Epica CDXi's electronic rear parking sensors makes parking in tight spaces a breeze.



8-speaker MP3 compatible in-dash audio system

Tune into your favourite radio station, load your favourite CD or plug in your MP3 player and surround yourself with the magnificent stereo reproduction of this superb audio system.



front fog lamps and sports body kit



climate control air conditioning



17" alloy wheels



optional leather appointed seats



* Maximum figures as per ECE regulations
* Certain mobile phones may not be compatible with vehicle's Bluetooth® system. Check with your phone dealer to determine your phones compatibility

features

engine / safety / exterior / interior	CDX	CDXi	interior / security	CDX	CDXi
engine and transmission			driver (continued)		
115kW/237Nm* 2.5 litre in-line 6-cylinder engine	•	•	Electronic driver information display, featuring 4 mode trip computer, climate control functions and compass	•	
110kW/320Nm* 2.0 litre 4-cylinder turbocharged common rail diesel engine (CDTi)	•	•	Bluetooth® kit for compatible mobile phones	•	•
6-speed automatic transmission with Active Select	•	•	Portable satellite navigation – full colour mapping	A	A
safety and control			audio		
Front MacPherson Struts with Rear Multi-Link Suspension	•	•	Radio/MP3 compatible CD player with auxiliary input and 6-speakers	•	
Electronic Stability Control (ESC) incorporating:	•	•	Radio/MP3 compatible 6-disc CD player with auxiliary input and 8-speakers	•	
Anti-lock Braking System (ABS)			In-glass antenna	•	•
Electronic Brakeforce Distribution (EBD)			Steering wheel mounted audio controls	•	•
Traction Control System (TCS)					
Front airbags for driver and front passenger, side impact airbags for driver and front passenger and side curtain airbags	•	•	seating		
Sensor deactivated passenger airbag	•	•	Cloth seat trim	•	•
Front seatbelt pretensioners and load limiters	•	•	Leather appointed seats		•
Front height adjustable seatbelts	•	•	8-way adjustable driver's seat with lumbar support	•	•
3 point lap/sash centre rear seatbelt	•	•	Seat back pockets on both front seats	•	•
Rear seat child restraint anchor points (3)	•	•	Rear seat head restraints (2)	•	
Child-proof rear door locks	•	•	Rear seat head restraints (3)	•	
Side impact intrusion beams	•	•	60/40 split fold rear seats	•	•
Brake transmission shift interlock	•	•	Rear seat armrest with cupholders (including storage bin on CDXi)	•	•
wheels			cabin comfort		
16" x 6" alloy wheels. 205/60 R16 tyres (4). Steel spare wheel (full-size 15")	•		Air conditioning	•	
17" x 7" alloy wheels. 215/50 R17 tyres (4). Steel spare wheel (full-size 15")		•	Climate control air conditioning	•	
exterior			Chrome finish interior door handles	•	•
Body coloured pullout door handles, mirrors and bumpers	•	•	Four cup holders (2 front/2 rear)	•	•
Projector headlamps	•	•	Centre console compartment with lid	•	•
Power exterior mirrors	•	•	Passenger overhead assist handles	•	•
Tinted windows	•	•	Sunglasses holder	•	•
Gas strut bonnet lifter and boot lifter	•	•	Shopping hook	•	•
Sports body kit			Vanity mirror, driver and front passenger	•	
Silver surround body coloured pullout door handles	•		Vanity mirror, driver and front passenger. Illuminated, with cover	•	
Front fog lamps	•		Floor mats, front and rear	A	A
Bonnet protector	A	A	Hot/cold cup holder	A	A
Headlamp protector (set of 2)	A	A	Rear cargo organiser	A	A
Tow bar and tongue kit (not available with rear parking sensors)	A		Boot lip protector	A	A
Weathershield	A	A	security		
driver			Remote control flip key operates doors and boot (2)	•	•
Power windows – front and rear	•	•	Engine immobiliser	•	•
Cruise control with steering wheel mounted switches	•	•	Anti-theft alarm for doors and boot	•	•
4-way adjustable steering column	•	•			
Rear window demister with timer	•	•	• standard		
Automatic Headlamp Mode. Switches on at twilight or low light	•	•	• optional		
Keyless entry for doors and boot	•	•	A accessory		
Rear parking sensors	A				
Leather wrap steering wheel and gear shifter	•				

* Maximum figures as per ECE regulations

technical specifications

	115kW, 2.5 litre L6 DOHC engine	110kW, 2.0 litre L4 SOHC diesel engine
Engine	Transverse mounted in-line 6 cylinder engine. Double overhead camshafts operating four valves per cylinder. Variable intake valve system. Multipoint fuel injection	In-line SOHC 16 valve 4 cylinder. Cast Iron block, aluminium head. Twin balance shafts to reduce vibration. Variable-Geometry. Turbocharger for wider torque band. Charge Air cooler. High-Pressure Common-Rail Direct Injection. Zero-maintenance Diesel Particulate Filter (DPF)
Bore x Stroke (mm)	77 x 89.2	83 x 92
Capacity (cc)	2492	1991
Compression ratio (:1)	9.8	17.5
Power (ECE, kW)*	115kW @ 5800rpm	110kW @ 4000rpm
Torque (ECE, Nm)*	237Nm @ 4600rpm	320Nm @ 2000rpm
Gear ratios	6sp Auto	6sp Auto
1st	4.449	4.449
2nd	2.908	2.908
3rd	1.893	1.893
4th	1.446	1.446
5th	1.000	1.000
6th	0.742	0.742
Reverse gear ratio	-2.871	-2.871
Recommended fuel	ULP	Diesel
Fuel tank capacity (L)	63L	65L
Steering	Power assisted rack and pinion	Speed sensitive power assisted rack and pinion
Electronic Stability Control (ESC)	Incorporating: Traction Control System (TCS), Anti-lock Braking System (ABS), Electronic Brakeforce Distribution (EBD)	
Suspension	Front: Independent MacPherson Strut with coil springs and stabiliser bar. Rear: Independent Multi-Link with coil springs and stabiliser bar.	
Track (mm)	Front: 1550 Rear: 1545	
Turn circle (kerb to kerb, m)	10.78	
Wheelbase (mm)	2700	
Exterior dimensions (mm)	Length	Width
	4805	1810
		1450
Interior dimensions (mm)	Leg	Shoulder
	1072	1443
	960	998
Front		962
Rear		
Boot volume (L)	480	
Towing (kg)	750 unbraked trailer, 1,200 braked trailer.	
Service	The complimentary inspection is due at 3,000km or 3 months (whichever occurs first). The first service is due at 15,000km or 12 months (whichever occurs first) and then every 15,000km or 12 months (whichever occurs first) since the last service. Additional services may be required under certain driving conditions such as when towing (refer to owner's handbook).	

*Maximum figures as per ECE regulations

colours and trims

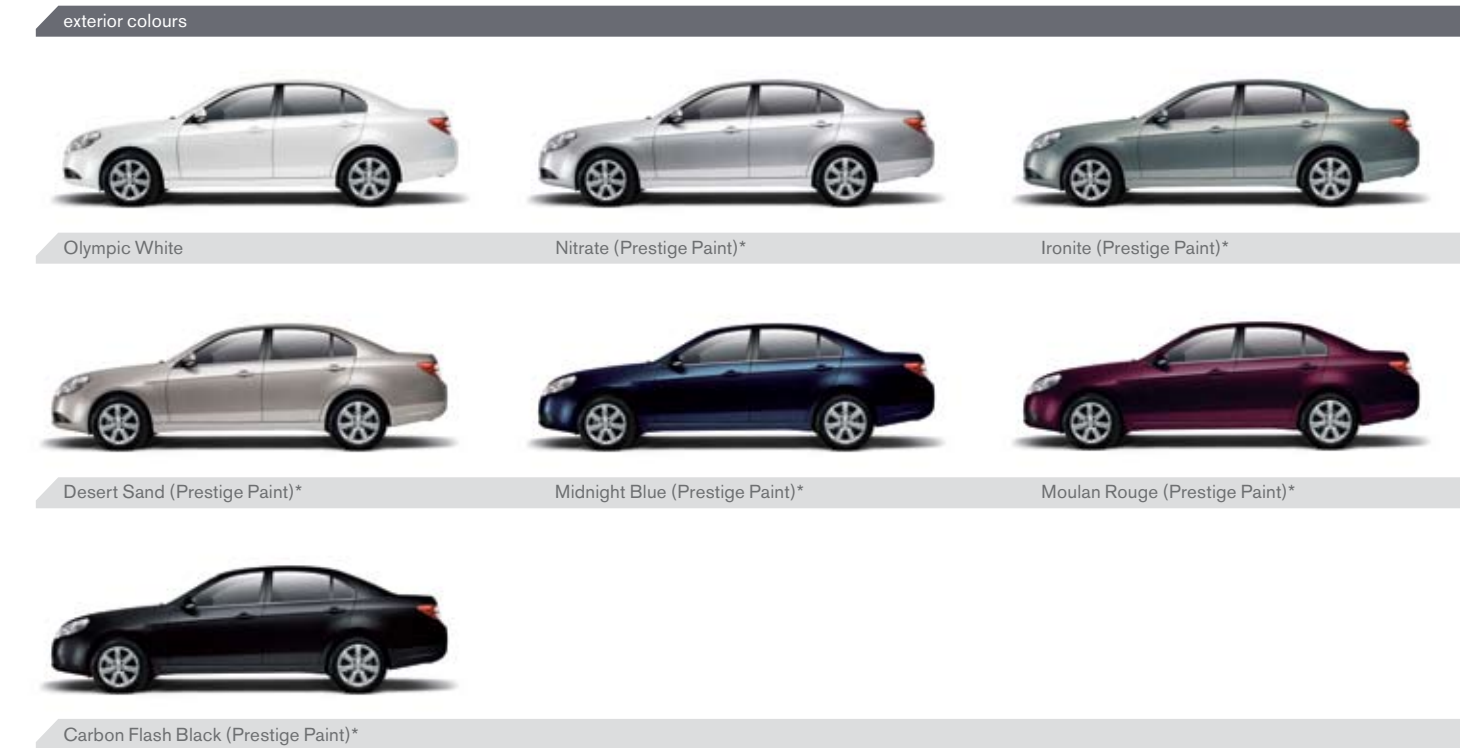

model	exterior colours							interior trim
	Olympic White	Ironite*	Thunder Grey*	Desert Sand*	Midnight Blue*	Moulou Rouge*	Carbon Flash Black*	
CDX	•	•	•	•	•	•	•	Punch cloth
CDXi		•	•		•		•	Punch cloth
		•	•		•		•	Charcoal leather appointed seats (optional)

*Prestige paints are available at an additional cost and certain colours may not be available from time to time. Variations between colours shown and actual paint colours/interior trim colours may occur due to the brochure printing process. Actual vehicle colours may appear different under certain light conditions. Customers are encouraged to contact their Holden Dealer for current colour availability.