

**CIVIC**



**HONDA**  
The Power of Dreams

Honda Australia Pty. Ltd. ACN 004 759 611 ABN 66 004 759 611  
95 Sharps Road, Tullamarine, Victoria, 3043. Freecall 1800 804 954. [honda.com.au/cars](http://honda.com.au/cars)

The specifications and major features listed herein are accurate as at the date of printing (August 2011/11YM). However, Honda Australia Pty. Ltd. reserve the right to change or modify specifications and major features at any time without prior notice. Due to ordering, shipping and freight factors, some colour and model availabilities may vary from time to time. Check with your Honda Dealer for current information on availability. Automatic transmission available for an extra cost. Only Genuine Honda Accessories are made to fit Honda vehicles. The fuel consumption figures quoted in this brochure are based on ADR81/02 test results. You may experience different results depending on driving conditions and the condition of the vehicle. Honda warranties apply where due care is exercised by the owner and the vehicle is maintained in accordance with the vehicle's owners manual. Please refer to Honda's warranty documentation for exclusions and conditions. Honda Australia Pty. Ltd. recommends careful examination of all official Honda warranty documentation before purchasing. This brochure is printed on 90% recycled paper, 80% post consumer fibre and 20% totally chlorine-free pulp. It is FSC certified mixed source paper which ensures that all virgin pulp is derived from well managed forests and is manufactured by an ISO 14001 certified mill. Civic Sport shown in Dyno Blue on cover. HON8607



Clever engineering with a whole lot of style

### Aerodynamic design

From its streamlined profile to its wide stance, the Civic is a textbook study in refined aerodynamics, not to mention head-turning good looks.



### Dual zone dash

The intuitive, curved Dual Zone dash helps you keep your eyes on the road by placing the most important details in plain view at the very top, and less immediate details in the lower zone.



### Performance

With its revolutionary i-VTEC engine, the Civic strikes the perfect balance between power and economy. Choose from a 1.8 litre, 2.0 litre, or hybrid engine to suit both your lifestyle, and your driving style.



### Safety

Peace of mind comes standard in every Civic, thanks to an impressive array of safety features including ACE body structure, Vehicle Stability Assist, active head restraints, ABS with EBD and no less than six airbags.



### Spacious

There's no such thing as wasted space inside the Civic. From the unique Z-shaped arm brake lever to the flat rear floor and 60:40 split folding rear seats,\* the Civic makes use of every available inch to make the interior wonderfully spacious and comfy.

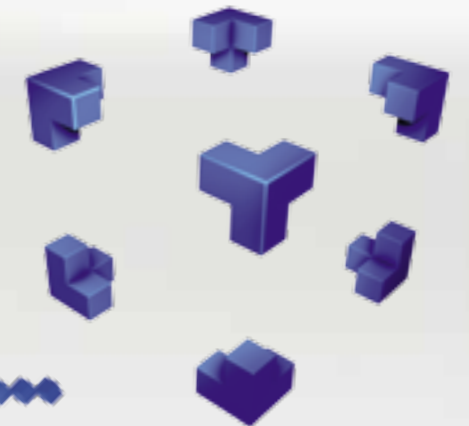

\*60:40 split rear seats available in the VTi-L and Sport models only. Civic VTi-L shown in Taffeta White.

# Elegance has never been so exhilarating

What if you could combine elegant design with meticulous engineering? Well, the engineers at Honda have done just that with the Civic, a car with sleek good looks and the quality finish Honda is renowned for.

The first thing you'll notice about the Civic is the elegant,

aerodynamic shape. But it's not just for looks alone. The streamlined body shape has been meticulously honed to improve fuel efficiency and driver visibility.

Inside the cabin, the Civic makes full advantage of some of Honda's best ideas, such as the Dual Zone dash,

remarkable space-saving design, plus a whole host of the latest safety systems.

And let's not forget the best feature of all: choice. The Civic is available in four variants – the 1.8 litre VTi and VTi-L, the powerfully precise 2.0 litre Sport and the highly efficient

Hybrid with Integrated Motor Assist.

But whichever you choose, you can be sure the Civic offers everything you could want in a small car, wrapped up in a decidedly stylish package.



Civic Sport shown in Dyno Blue.



## Hit the road in style *~*

Why does the Civic look like it's going fast, even when it's standing still? It's all down to the one-sweep design, which not only gives the Civic its sleek, modern look but improved aerodynamic performance out on the road.

Accentuated by a low, sporty stance, the fluid curve of the front end leads up to the uniquely designed aerodynamic windscreen rake, improving fuel efficiency and driver visibility. Of course, a unique windscreen isn't complete without unique windscreen wipers, so the Civic makes use of opposable wipers which cover 17% more surface area than the conventional ones.

At first glance, you may not notice all the exceptional details on the Civic's refined exterior. And that's just the point. Every feature has been crafted to enhance, rather than interrupt the smooth, flowing lines, like the stylish metallic front grille, colour-coded wing mirrors and octagonal rear lights that fit snugly within the smooth bodywork of the tail end.

As you move up the Civic range, you'll discover a wealth of brilliant additions, with the VTi-L model boasting extras such as alloy wheels, fog lights and rear park assist. And for those who appreciate all the trimmings, there's the Civic Sport which is also kitted out with 17-inch alloy wheels, sunroof, dual chrome exhaust pipes and mirror-mounted side indicators.

Take a moment to examine the Civic's exterior, and you'll come to a conclusion that Honda's engineers have known for a long time. That aerodynamic design is a beautiful thing.

# Behind the wheel. Ahead of the game

From the second you get behind the wheel, it's easy to feel like you've driven the Civic before – as if it was built just for you.

Everything you need is front and centre, thanks to the revolutionary Dual Zone dash. A product of Honda's research into the eye movements of drivers, this unique, multi-tiered display places the most commonly referenced details into the driver's line of sight, so you can check your speed while still keeping your eyes on the road ahead.

If you're a fan of gadgets, you've come to the right place, as the Civic is filled with loads of handy features, such as Bluetooth® phone system\*, power door mirrors and remote keyless entry with boot release. The VTi-L and Sport models also feature climate control as standard, and for the ultimate in interior luxury, the Sport adds plush leather-appointed seats, a leather-wrapped steering wheel, and electric glass sunroof with tilt and slide functionality.

Naturally, a good road trip is always better with your favourite tunes, so the Civic has a fully integrated audio system with MP3/WMA compatible CD player and MP3 auxiliary input. The VTi-L and Sport models take things up a notch, with a 6-CD stacker and steering wheel-mounted controls. Speaking of which, all models come with Speed-sensitive Volume Compensation (or SVC for short) so you can enjoy smooth, pitch-perfect listening at any speed.

There's no mistaking the feeling that the Civic has been built just for you. Because when it comes to comfort and convenience, Honda really has thought of everything. And they've placed it right at your fingertips.

\*The Bluetooth word mark is owned by the Bluetooth SIG, Inc. and use of such mark by Honda is under licence. Please check the list of compatible phones at [honda.com.au/bluetooth](http://honda.com.au/bluetooth)



Civic Sport shown.



Civic Sport shown.

## There's always space for new ideas

At Honda, they believe comfort is crucial. That's why the Civic features ergonomically sculpted front seats, a driver's seat height adjuster and a tilt and telescopic steering wheel to help you find your ideal driving position.

It's also important to have plenty of room for the things (and people) you love, so the Civic is full of smart, space-saving

ideas that make the interior more spacious and comfortable than you ever thought possible.

The Z-shaped arm brake lever has been specifically designed to free up space in the front. The gear shift has been positioned to give you more room to move. Even the fuel tank is positioned to create an innovative flat rear floor, for even greater legroom in the back.

And as they're riding along in comfort, your passengers will also be impressed by the host of clever interior storage options, including a generous centre console with large sliding armrest.

Or if you're carrying more cargo instead of more passengers, the rear seats fold totally flat in one smooth motion to create

an extraordinary amount of space, with 60:40 split rear seats in the VTi-L and Sport models.\*

So whatever (or whoever) you take in the Civic, you'll always travel in comfort and style.

\*Fold down rear seats not available in the Hybrid model.

# Drive the best of both worlds

What if you didn't have to choose between economy and performance? What if you could have both?

In the Civic, you can. The super-smooth 1.8 litre i-VTEC engine in the VTi and VTi-L models delivers 103kW of power and 174Nm of torque, all while using a miserly 6.9 L/100km\*. That's efficiency similar to a 1.6 litre with the power you'd expect from a 2.0 litre engine. Speaking of power, for those who appreciate a little more of it, there's the Civic Sport and its impressive 2.0 litre DOHC i-VTEC engine which delivers 114kW of power and 188Nm of torque, all on just 8.3 L/100km\*. Regardless of which engine you choose, you can be sure its impressive performance will be matched by impressively low CO2 emissions.

When it comes to transmissions, the Civic shines again, with the choice of a 5-speed manual or 5-speed automatic. The automatic comes with Honda's Grade Logic Control, a unique system that adjusts to inclines and declines instantly, eliminating 'gear hunting' so you can enjoy a smoother ride. Choose the Civic Sport, and you'll find the power is (literally) in your hands, with its steering wheel-mounted gearshift paddles.



Put the Civic through its paces, and you'll find the ride smooth, precise and wonderfully responsive. The suspension system has been thoughtfully engineered with MacPherson front and double wishbone rear for nimble handling and refined ride quality. Even the acceleration is more responsive, thanks to the electronic drive-by-wire throttle, which does away with inefficient mechanical connections, instead using precision electronics that respond directly from the accelerator to the engine.

Combine this with power steering, and suddenly every twist and turn becomes effortless, and even the most challenging parking space is a breeze. Select the Civic Sport, and the benefits increase with a lightweight, speed-sensitive Electric Power Steering (EPS) system.

You may not be able to see all the Civic's advanced features, but you can certainly feel the quality and precision every time you take the wheel.

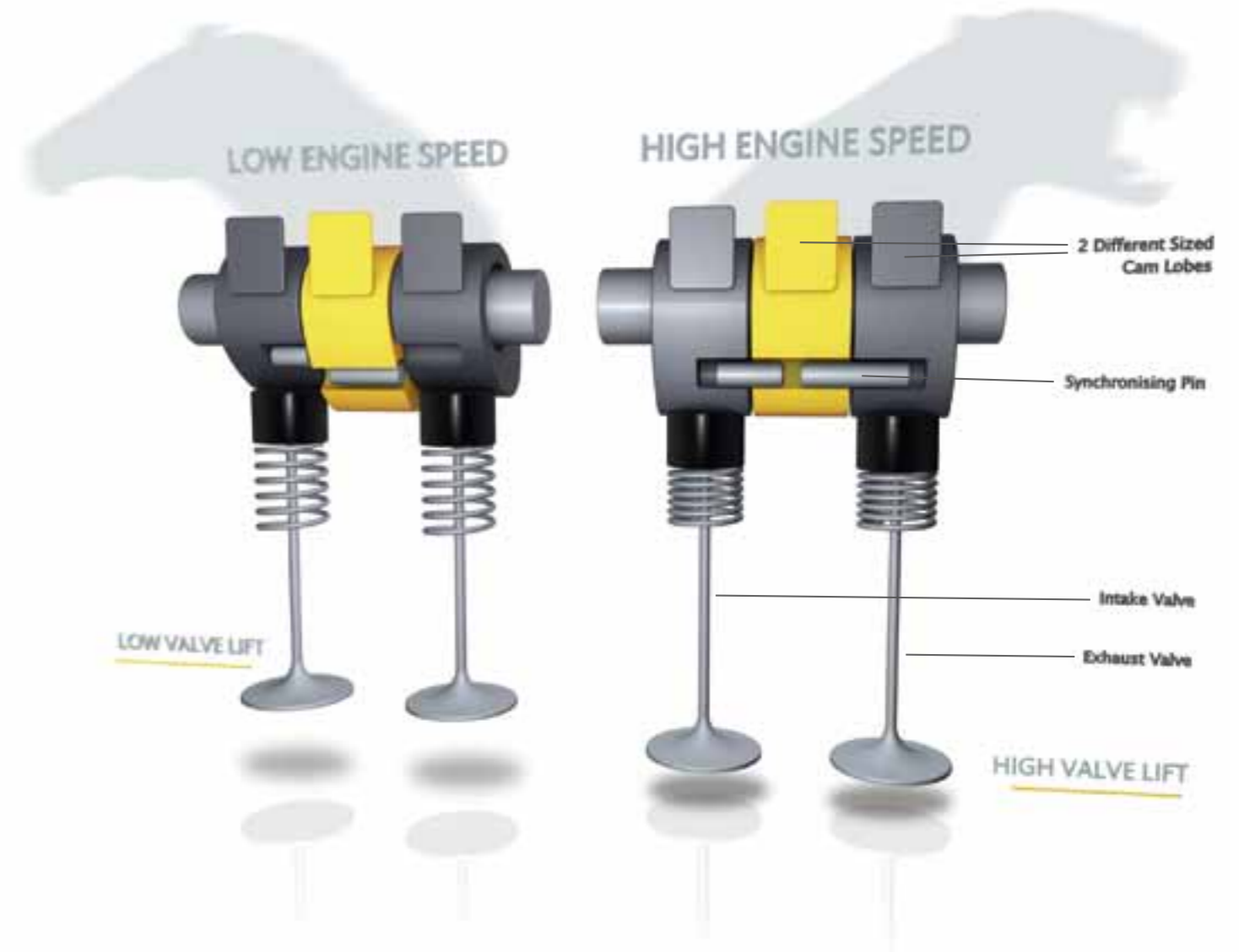

When Honda created the i-VTEC engine, motoring was changed forever. Up until that point, engines were typically either economical or powerful, but not both.

Using a clever cam widget, i-VTEC has the incredible ability to recognise throttle speed and regulate fuel use accordingly.

It operates by using low fuel at low engine revs, but still giving higher performance at high engine revs.

Thanks to the power of i-VTEC, your Civic is endearingly economical, yet satisfyingly responsive just when you need it.

# Handling safety with care

When it comes to safety, Honda is dedicated to going above and beyond, inside and out. Not content to simply meet government regulations, Honda has always been committed to leading the way, with innovations that help make the roads a safer place for everyone.

It's this fierce dedication that led Honda to develop the world's first pedestrian crash-test dummy, and more recently, the

world's first indoor omni-directional crash test facility. Located in Japan, it's the size of a major league baseball field! Inside, Honda's engineers simulate real-world collisions, testing vehicles of different sizes at various angles and speeds. The results have driven some of Honda's most ingenious safety systems, including the ACE body structure, which of course can be found in the Civic.

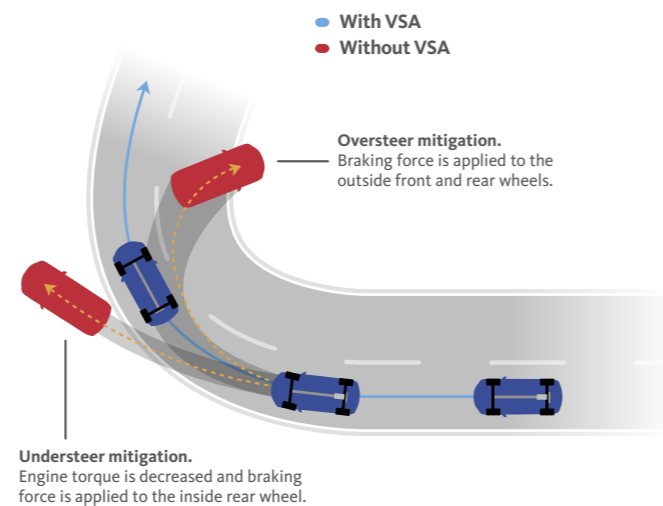

Honda's Advanced Compatibility Engineering (ACE) body structure has been deftly designed to offer the utmost protection for you and your passengers. It absorbs the energy from an impact, and actively channels it away from the passenger compartment.

Vehicle Stability Assist (VSA) works together with the Anti-lock Braking System and Traction Control System to maintain control in oversteer or understeer situations. VSA carefully combines braking and control of the engine's power to regain traction.

Naturally, Honda's steadfast commitment to safety also extends inside the cabin, with front active head restraints, front seatbelt pre-tensioners and six airbags as standard. But they're not just any airbags. The dual front airbags can sense the speed and severity of a crash and deploy themselves accordingly, while the side airbags feature Honda's clever Occupant Position Detection System (OPDS) which prevents

deployment of the passenger side airbag if it senses a child or smaller person in its path. And to make sure you're totally surrounded in safety, there's full-length curtain airbags as well.







Civic Sport shown in Dyno Blue.



Civic Hybrid shown in Neutron Blue.

## The elegantly responsible Civic Hybrid

And now for the Civic that drives straight into the future. The Civic Hybrid brings together Honda's ingenious hybrid technology with the sleek style and clever features that Civic is renowned for.

Under the hood, the Civic Hybrid is powered by Honda's Integrated Motor Assist (IMA). Combining a 1.3 litre i-VTEC petrol engine with an electric motor, it produces 85kW @ 6000rpm all while using only 4.6 litres per 100km\*.

So how does this system achieve the previously impossible? It's quite simple really. Firstly, the engine draws on the electric motor for supplementary power during acceleration.

During low-speed cruising, the electric motor takes over, and when braking, it acts as a generator to replenish the battery pack so it never needs recharging from an external power supply.

In optimum conditions, the engine automatically switches itself off when idle, which keeps fuel consumption and running costs to an absolute minimum. So helping the environment helps your hip pocket as well.

The Civic Hybrid also comes with an advanced automatic Continuously Variable Transmission (CVT) as standard. This snazzy transmission adjusts to your driving style,

seamlessly changing the final drive ratio, so you'll enjoy optimum engine output with even greater fuel economy.

And to ensure it's thoroughly efficient in every way, the Civic Hybrid's exterior offers brilliant aerodynamics with minimal wind resistance. Even the 15" alloy wheels are a special low-drag design, created exclusively for the Civic Hybrid.

So with the Civic Hybrid, the future is looking very bright indeed.

\*The fuel consumption figure is based on ADR81/02 combined test results for Civic Hybrid.



## Civic VTi

The Civic VTi comes standard with:

### POWERTRAIN

- 1.8 litre SOHC i-VTEC engine
- 103kW @ 6300rpm and 174Nm @ 4200rpm
- 5-speed manual or automatic transmission
- Drive-by-wire (DBW) throttle
- Hydraulic power steering

### EXTERIOR

- 15-inch steel wheels with full size spare
- Body coloured door handles
- Body coloured front and rear bumpers
- Dual exhaust
- Halogen headlights
- Remote keyless entry and boot release

### INTERIOR

- Air conditioning
- Bluetooth® phone system\*
- Centre console with sliding armrest
- Cloth seat and interior trim
- Cruise control
- Power windows with auto-up/down driver's window
- Single fold down rear seats
- Tilt and telescopic steering wheel
- AM/FM radio, single CD player (MP3/WMA compatible)
- MP3 auxiliary jack
- Speed-sensitive Volume Compensation (SVC)

### SAFETY

- Advanced Compatibility Engineering (ACE) body structure
- Anti-lock Braking System (ABS) with Electronic Brake-force Distribution (EBD)
- Front, side and full length curtain airbags
- Front active head restraints
- Honda G-Con Technology
- Immobiliser system
- Vehicle Stability Assist (VSA) with Traction Control



Grey cloth seat trim



## Civic VTi-L

Additional features over the VTi:

- 16-inch alloy wheels
- 60/40 split fold down rear seats
- 6-stack in-dash CD player with MP3/WMA compatibility
- Climate control air-conditioning
- Deluxe tailored floor mats
- Front fog lights
- Outside temperature display
- Rear park assist
- Security alarm
- Steering wheel-mounted audio controls



Grey cloth seat trim



## Civic Sport

Additional features over the VTi-L:

- 2.0 litre DOHC i-VTEC engine
- 114kW @ 6200rpm and 188Nm @ 4200rpm
- 17-inch alloy wheels
- Dual chrome exhaust finishers
- Electric Power Steering (EPS)
- Electric sunroof
- Full-size spare alloy wheel
- Leather appointed seat and interior trim
- Leather wrapped steering wheel
- Mirror mounted side indicators
- Steering wheel-mounted paddle shift controls (auto only)
- Wipers: 2 speed and variable intermittent

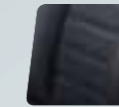

Black leather-appointed seat trim



## Civic Hybrid

The Civic Hybrid comes standard with:

### POWERTRAIN

- 1.3 litre SOHC i-VTEC engine with Integrated Motor Assist (IMA)
- 85kW @ 6000rpm and 170Nm @ 2500rpm
- 'CVT' automatic transmission with Grade Logic Control
- Drive-by-wire (DBW) throttle system
- Electric Power Steering (EPS)

### EXTERIOR

- 15-inch alloy wheels
- Halogen headlights
- Remote keyless entry and boot release

### INTERIOR

- Leather wrapped steering wheel
- Climate control air-conditioning
- Bluetooth® phone system\*
- Power windows with auto up/down on all
- Tilt and telescopic adjustable steering wheel
- 6-stack in-dash CD player with MP3/WMA compatibility
- MP3 auxiliary jack

### SAFETY

- Advanced Compatibility Engineering (ACE) body structure
- Anti-lock Braking System (ABS) with Electronic Brake-force Distribution (EBD)
- Front, side and full length curtain airbags
- Front active head restraints
- Honda G-Con technology
- Vehicle Stability Assist (VSA) with Traction Control



Beige cloth seat trim



CIVIC



SPARKLE GREY

CIVIC AND CIVIC HYBRID



ALABASTER SILVER

CIVIC HYBRID



URBAN TITANIUM



DYNO BLUE



NEUTRON BLUE



TAFFETA WHITE



HABANERO RED



BRIGHT RED



CRYSTAL BLACK

Clever engineering, brilliant colours

^Metallic and ^Pearlescent paint additional cost.

# Civic Specifications

Description	Civic VTi	Civic VTi-L	Civic Sport	Civic Hybrid
<b>POWERTRAIN</b>				
Engine	Inline 4-cylinder SOHC i-VTEC	Inline 4-cylinder SOHC i-VTEC	Inline 4-cylinder DOHC i-VTEC	Inline 4-cylinder SOHC i-VTEC with IMA
Capacity	1.8 litre – 1799 cc	1.8 litre – 1799 cc	2.0 litre – 1998 cc	1.3 litre – 1339 cc
Maximum power	103kW @ 6300rpm	103kW @ 6300rpm	114kW @ 6200rpm	85kW @ 6000rpm <sup>o</sup>
Maximum torque	174Nm @ 4200rpm	174Nm @ 4200rpm	188Nm @ 4200rpm	170Nm @ 2500rpm <sup>o</sup>
CO <sub>2</sub> emissions (g/km) – manual	164	164	197	–
– automatic	171	171	200	109
Manual transmission	5-speed	5-speed	5-speed	–
Automatic transmission	5-speed with Grade Logic Control	5-speed with Grade Logic Control	5-speed with Grade Logic Control	Continuously Variable Transmission (CVT)
– with transmission shift lock	✓	✓	✓	✓
– with steering wheel mounted paddle shift	–	–	✓	–
Fuel type	Unleaded (91RON or higher)	Unleaded (91RON or higher)	Unleaded (91RON or higher)	Unleaded (91RON or higher)
Fuel supply system	Honda Programmed Fuel Injection (PGM-FI)	Honda Programmed Fuel Injection (PGM-FI)	Honda Programmed Fuel Injection (PGM-FI)	Honda Programmed Fuel Injection (PGM-FI)
Fuel consumption combined (litres/100km)*				
– manual	6.9	6.9	8.3	–
– automatic	7.2	7.2	8.4	4.6
Fuel consumption urban (litres/100km)*				
– manual	9.3	9.3	11.5	–
– automatic	10.4	10.4	11.9	5.2
Fuel consumption extra urban (litres/100km)*				
– manual	5.5	5.5	6.5	–
– automatic	5.3	5.3	6.4	4.3
Drive By Wire throttle system (DBW)	✓	✓	✓	✓
<b>CHASSIS</b>				
Body type	Monocoque	Monocoque	Monocoque	Monocoque
Front suspension	MacPherson strut	MacPherson strut	MacPherson strut	Independent
Rear suspension	Double wishbone	Double wishbone	Double wishbone	Double wishbone
Stabiliser bars	Front and rear	Front and rear	Front and rear	Front and rear
Steering system type	Hydraulic assist	Hydraulic assist	Electric assist	Electric assist
Front brakes	Ventilated disc	Ventilated disc	Ventilated disc	Ventilated disc
Rear brakes	Solid disc	Solid disc	Solid disc	Solid disc
<b>EXTERIOR</b>				
Body coloured door handles	✓	✓	✓	✓
Body coloured front and rear bumpers	Impact absorbing	Impact absorbing	Impact absorbing	Impact absorbing
Body coloured power door mirrors	✓	✓	With turn indicators	With turn indicators
Electric sunroof	–	–	✓	–
Exhaust	Dual	Dual	Dual (chrome)	Single
Front fog lights	■	✓	✓	✓
Headlights	Halogen	Halogen	Halogen	Halogen
Remote keyless entry with boot release	✓	✓	✓	✓
Rear window demister	✓	✓	✓	✓
Wipers	2-speed and intermittent	2-speed and intermittent	2-speed and variable intermittent	2-speed and variable intermittent
<b>INTERIOR</b>				
Accessory power outlet (12v)	✓	✓	✓	✓
Air conditioning	✓	Climate control	Climate control	Climate control
Ashtray	Front	Front	Front	Front
Central locking	✓	✓	✓	✓
Cruise control	✓	✓	✓	✓
Cup-holders	2 (Front)	2 (Front)	2 (Front)	4 (Front and rear)
Deluxe tailored floor mats	■	✓	✓	■
Digital clock (in radio)	✓	✓	✓	✓
Door pockets	All doors	All doors	All doors	All doors
Driver's footrest	✓	✓	✓	✓
Driver seat height adjustment	✓	✓	✓	✓
Glovebox	✓	✓	✓	✓
Head restraints (height adjustable)	5	5	5	5
Interior light	✓	✓	✓	✓
Lights-on warning (audible)	✓	✓	✓	✓
Low fuel warning light	✓	✓	✓	✓
Luggage area light	✓	✓	✓	✓
Map lights	2	2	2	2
Outside temperature display	–	✓	✓	✓
Power windows	✓	✓	✓	✓
– auto up/down	Driver	Driver	Driver	Driver
Remote fuel filler release	✓	✓	✓	✓
Seats	– front Fully reclining	– front Fully reclining	– front Fully reclining	– front Fully reclining
– rear Single fold down	60/40 split fold down	60/40 split fold down	60/40 split fold down	With armrest
Seat back pocket	Passenger side	Passenger side	Passenger side	Passenger side
Seatbelt height adjuster	Front	Front	Front	Front
Seat trim material	Cloth	Cloth	Leather	Cloth
Steering column	Tilt and telescopic adjustment	Tilt and telescopic adjustment	Tilt and telescopic adjustment	Tilt and telescopic adjustment
Steering wheel	Urethane	Urethane	Leather wrapped	Leather wrapped
Tachometer	✓	✓	✓	✓
Tripmeter	2	2	2	2
Vanity mirrors	Driver and front passenger	Driver and front passenger	Driver and front passenger	Driver and front passenger
Windows	Heat absorbing	Heat absorbing	Heat absorbing	Heat absorbing

# Civic Specifications

Description	Civic VTi	Civic VTi-L	Civic Sport	Civic Hybrid
<b>SAFETY AND SECURITY</b>				
Advanced Compatibility Engineering (ACE) body structure	✓	✓	✓	✓
Airbags i-SRS – front	Driver and front passenger	Driver and front passenger	Driver and front passenger	Driver and front passenger
Airbags SRS – side with OPDS	Driver and front passenger	Driver and front passenger	Driver and front passenger	Driver and front passenger
– curtain	Full length	Full length	Full length	Full length
Anti-lock Braking System (ABS)	✓	✓	✓	✓
Brake Assist	✓	✓	✓	✓
Child proof rear door locks	✓	✓	✓	✓
Child safety seat anchorages	3	3	3	3
Convex door mirrors	✓	✓	✓	✓
Electronic Brake-force Distribution (EBD)	✓	✓	✓	✓
Fire retardant interior	✓	✓	✓	✓
Front active head restraints	✓	✓	✓	✓
Front windscreen	Laminated	Laminated	Laminated	Laminated
Fuel tank roll-over valve	✓	✓	✓	✓
Hazard warning lights	✓	✓	✓	✓
High mounted brake light	✓	✓	✓	✓
Honda G-force Control technology (G-Con)	✓	✓	✓	✓
Immobiliser system	✓	✓	✓	✓
Progressive crumple zones	Front and rear	Front and rear	Front and rear	Front and rear
Rear park assist	■	✓	✓	■
Rear view mirror	Day/night type	Day/night type	Day/night type	Day/night type
Screw type fuel cap	✓	✓	✓	✓
Seatbelt pretensioners with load limiters	Front	Front	Front	Front
Seatbelt reminder	Driver	Driver	Driver	Driver
Seatbelts – 3-point ELR	Front seating positions	Front seating positions	Front seating positions	Front seating positions
– 3-point ELR/ALR	Rear seating positions	Rear seating positions	Rear seating positions	Rear seating positions
Security alarm system	–	✓	✓	✓
Side impact protection door beams	✓	✓	✓	✓
Steering column	Energy absorbing	Energy absorbing	Energy absorbing	Energy absorbing
Vehicle Stability Assist (VSA) with Traction Control System (TCS)	✓	✓	✓	✓
<b>DIMENSIONS/WEIGHTS/CAPACITIES</b>				
Boot capacity (litres)	376	376	376	360
Overall length (mm)	4550	4550	4550	4550
Overall width (mm)	1750	1750	1750	1750
Overall height (mm)	1435	1435	1435	1430
Ground clearance – laden (mm)	115	115	115	110
Kerb weight (kg) – manual	1180	1190	1265	–
– automatic	1210	1220	1295	1265
Turning circle at wheel centre (metres)	10.6	10.6	10.8	10.8
Fuel tank capacity (litres)	50	50	50	50
Maximum towing capacity (kg)				
– trailer with brakes				
– manual	1200	1200	1200	Not recommended
– automatic	450	450	450	Not recommended
– with ATF cooler	800	800	800	Not recommended
– trailer without brakes				
– manual	500	500	500	Not recommended
– automatic	450	450	450	Not recommended
– with ATF cooler	500	500	500	Not recommended
Seating capacity	5	5	5	5
Wheel base (mm)	2700	2700	2700	2700
<b>TYRES AND WHEELS</b>				
Wheel size	15 x 6.0J	16 x 6.5J	17 x 7.0J	15 x 6JJ
Tyre size	195/65 R15 91H	205/55 R16 91V	215/45 R17 91V	195/65 R15 91H
Wheel type	15" Steel	16" Alloy	17" Alloy	15" Alloy
Spare wheel type	Full size steel	Full size steel	Full size alloy	Temporary
<b>MULTIMEDIA</b>				
Single CD player (MP3/WMA Compatibility), AM/FM radio	✓	–	–	–
6 CD stacker (MP3/WMA Compatibility), AM/FM radio	–	✓	✓	✓
Antenna	In-glass	In-glass	In-glass	Roof
Auxiliary jack	✓	✓	✓	✓
Bluetooth® phone system <sup>o</sup>	✓	✓	✓	✓
Speakers – front door	2	2	2	2
– rear door	2	2	2	2
Speed-sensitive Volume Compensation (SVC)	✓	✓	✓	✓
Steering wheel mounted audio controls	–	✓	✓	✓
<b>WARRANTY</b>				
Vehicle – 3-year or 100,000km warranty <sup>1</sup>	✓	✓	✓	✓
Vehicle – 6-year rust perforation warranty <sup>1</sup>	✓	✓	✓	✓
IMA battery – 8 years unlimited km warranty <sup>1</sup>	–	–	–	✓

✓ Standard feature. ■ Accessory option. – Not available. \*The fuel consumption figures quoted are based on ADR81/02 test results. You may experience different results depending on driving conditions and the conditions of the vehicle. <sup>o</sup>Civic Hybrid power and torque figures are based on the combination of petrol and electric engines. <sup>o</sup>The Bluetooth word mark is owned by the Bluetooth SIG, Inc. and use of such mark by Honda is under licence. Please check the list of compatible phones at [honda.com.au/bluetooth](http://honda.com.au/bluetooth) <sup>1</sup>Honda warranties apply where due care is exercised by the owner and the vehicle is maintained in accordance with the vehicle's owners manual. Please refer to Honda's warranty documentation for exclusions and conditions.



JAZZ



CITY



CIVIC



CIVIC HYBRID



INSIGHT



CIVIC TYPE R



CIVIC SI



ACCORD



ACCORD EURO



CR-V



ODYSSEY



LEGEND



### Rear ducktail spoiler

The subtle shape of this ducktail spoiler adds a sporty edge to the Civic's refined body. (Not compatible with Hybrid model).



### Chrome exhaust pipe finisher

This very last detail makes all the difference to a well-appointed Civic exterior. (For VTi and VTi-L models only).



### Fog light set

When the weather takes a turn for the worse, these precision optics will enhance your visibility. And thanks to their integrated design, they'll also enhance the appearance of your Civic. (For VTi model only).



### Alloy wheels

Available in three different sizes, depending on the Civic model you choose. These wheels will make a sleek and sporty addition to your already very stylish Civic. 15" for VTi (left), 16" for VTi-L (centre) and 17" for Sport (right).

## Style up your Civic

And now for the fun part... Accessorising your Civic with some finishing touches to really make it yours.

Like all good accessories, they're both functional and fashionable, so choose the complete set, or your own unique combination to create the Civic of your dreams.



Civic VTi shown fitted with 15" alloy wheels, fog light set and Modulo Sports Pack accessories.



## Modulo Sports Pack

- Front under spoiler
- Rear under spoiler<sup>M</sup>
- Side skirt set<sup>Q</sup>
- Rear boot spoiler (wing type)

### Accent light set

Your Civic will take on a different character by night, with a soft blue glow that lights up the interior.



### Interior panel set

Choose an extra level of finish to give your dashboard a strong, sharp look. This 4-piece set is available in carbon-style or metal-style finish (as shown).



### Door sill garnish set

A smart accessory you're sure to appreciate every time you step into your Civic. This 4-piece set not only looks great, it offers extra protection for your door sills. Choose from illuminated blue<sup>O</sup> (left) or non-illuminated metal-finish (right).



### Bass Works speaker system

Pump up the volume with this seamlessly integrated amplifier and rear speaker set, specifically designed to enrich the deep bass tones of your music. Fully adjustable to suit driver or passenger tastes.



See your Honda Dealer for advice regarding Genuine Honda Accessories. Pictured accessories are all sold separately. All Genuine Honda Accessories installed at the time of retail sale of a new motor vehicle are covered by Honda's 3-Year/100,000km Warranty. If installed after retail sale, they are covered for the remainder of the warranty or a minimum of 12 months - whichever is greater - provided that the accessory is fitted only to the vehicle for which it was intended by Honda Motor Co.

<sup>O</sup>The illuminated door sill garnish set includes illuminated front door and non-illuminated door sill garnishes. <sup>M</sup>Rear under spoiler is not compatible with the accessory rear mud guard set. <sup>Q</sup>Side skirt set is not compatible with the accessory front mud guard set.

## Fun and functional accessories

It's fun to get a little adventurous now and then, and happily, your Civic can always keep up. Whether you're into action-packed sports, or just some serious retail therapy, you can rely on Honda Genuine Accessories to work effortlessly, and blend seamlessly with the sleek lines of your vehicle. To find out more simply contact your local Dealer or visit [honda.com.au/civic](http://honda.com.au/civic)

### Other accessories available:

- Bonnet protector
- Car body cover
- Door visor set
- Drink and utility holder set
- Dust and pollen cabin filter
- Headlight protectors
- Leather maintenance kit
- Front and rear black mud guard sets<sup>a</sup>  
(Sold separately)
- Roof rack attachments
  - Roof Box (36kg weight capacity)
  - Kayak attachment
  - Universal attachment
  - Tie downs
- Sunroof visor
- Touch-up paint
- Tow bar kit<sup>f</sup>  
(Optional automatic transmission cooler available)
- Tongue and tow ball storage bag<sup>f</sup>
- Wheel lock nut set



### Deluxe tailored mat set

You'll hardly notice these durable mats until you see how well they've preserved the Civic's stylish interior in years to come.  
(For VTi and Hybrid models only).



### Rear park assist

You can never be too careful when it comes to people or objects behind the car. Keep alert while reversing with these parking sensors that let out a timely beep when things get too close.  
(For VTi and Hybrid models only).



### Bootlip protector

This cleverly designed neoprene protector drapes over the bootlip to prevent accidental paint damage. Secured by a velcro strip while driving, simply fold it away flat when not in use.



### Cargo net

This tight-fitting flexible cord mesh keeps your odds and ends safely tucked away to guard them and the interior from damage.  
(Not compatible with Hybrid model).



### Organiser box

This nifty system helps keep the boot neat and tidy and can fold away flat when not in use.



### Luggage area protector tray

With all the bits and bobs that go into the boot, it's a good idea to protect the cargo area from scuffs and spills. And that's exactly what you can expect from this precise fitting, high-sided protector tray.  
(Not compatible with Hybrid model).



### Roof rack set<sup>±</sup>

These aerodynamic roof racks are simple to install and remove, and depending on your choice of roof attachment, can hold up to 50kg of bikes, skis, snowboards, or even kayaks.



### Ski/snowboard attachment

Before you hit the slopes, attach these to the roof rack to keep the inside free for you and your passengers.



### Bike carrier attachment

Designed to hold your bike securely, this absolute must for dedicated riders easily attaches to the roof rack.

See your Honda Dealer for advice regarding Genuine Honda Accessories. Pictured accessories are all sold separately. All Genuine Honda Accessories installed at the time of retail sale of a new motor vehicle are covered by Honda's 3-Year/100,000km Warranty. If installed after retail sale, they are covered for the remainder of the warranty or a minimum of 12 months - whichever is greater - provided that the accessory is fitted only to the vehicle for which it was intended by Honda Motor Co.

<sup>a</sup>In the interest of aerodynamics, Honda recommends the roof rack set be removed when not in use. <sup>b</sup>The front mud guard set is not compatible with the accessory side skirt set. The rear mud guard set is not compatible with the accessory rear under spoiler. <sup>c</sup>Not applicable to Hybrid model. See specifications page for load ratings.

## You're never alone in a Honda

Buy a Civic and you'll be amazed at how well you'll be looked after.

The care starts with a 3-year/100,000km warranty and 6-year rust perforation warranty<sup>§</sup>

And for a small extra investment, you can enjoy a huge amount of peace-of-mind with Honda Warranty Plus<sup>§</sup> including Premium Roadside Assist.

Plus, as a Civic owner you're entitled to a five year subscription to *Honda. The Magazine* and access to our exclusive HondaONE website. This secure site gives you all the important information you never knew where to find, like up-to-date service history, vehicle records, maintenance tips and personalised service reminders.

And by using your Honda Dealer, you'll also be sure that they'll protect your investment by using Honda Genuine Parts.

So with all these benefits, your Civic will be as pleasurable to own as it is to drive.

## Insurance

If you're looking for cover every bit as reliable as your Civic, you really need Honda Motor Vehicle Insurance.

You'll enjoy a range of benefits, including:

- 3-year new replacement if your Honda is a total loss;
- Genuine Honda approved parts for the first 5 years;
- Lifetime guarantee on authorised repairs.

Approved applicants only. Normal underwriting and excess payment rules apply.<sup>^</sup>

## Finance

Whether you're buying a Honda for yourself or a business, we have a wide range of flexible finance and leasing options.

So see your Honda Dealer to find a financial solution that suits you as perfectly as your Civic does.

## What's next?

As a Civic owner, you're part of a brand that's always doing something new.

Because if there's one thing Honda prides itself on, it's always asking, "What's next?"

It was this inventive spirit that led to developing the Civic's brilliantly intuitive Multiplex dash.

It also produced the new CR-Z, the world's first sporty hybrid coupe.

And that's not our first 'world first' either.

There's the FCX Clarity, which is powered by a hydrogen cell and whose only emission is water vapour.

Or the unique CIGS solar cells that produce twice as much energy than they take to make.

Then of course there's ASIMO, the world's most advanced humanoid robot and the incredibly fuel-efficient Hondajet.

And now there's a glimpse of the future with the altogether different U3-X, a personal mobility device that takes you in any direction by simply shifting your weight.

All of these things, which were once dreams, are now realities thanks to Honda.

So what's next?

<sup>§</sup>Honda warranties apply where due care is exercised by the owner and the vehicle is maintained in accordance with the Owner's Warranty and Service Manual. Please visit [honda.com.au/warranty](http://honda.com.au/warranty) for full terms and conditions. <sup>^</sup>Honda motor vehicle insurance is issued by GIO General Limited ABN 22 002 861 583 (GIO). Conditions and exclusions apply. Please read the Product Disclosure Statement before making any decision regarding this product and whether it is appropriate to meet your needs. To obtain a copy, please contact Honda on 1300 780 964. Honda dealers are either authorised representatives or insurance distributors of GIO.



Civic VTi shown in Taffeta White.