

 NEW THINKING.
HYUNDAI | NEW POSSIBILITIES.

iLoad van



About Hyundai.

Hyundai is one of the world's fastest growing car companies. We've achieved this position by applying a process of continual improvement and re-imagination. Our focus today is on producing cars that embody quality, variety, innovation and individuality... cars like the iLoad that inspire and create desire.

We believe that our progress isn't measured by our actions in the past, but by how we respond to our environment and listen to our customers. Only by re-imagining what tomorrow's world will bring, can we continue to evolve and meet your needs now and into the future. If that's the journey you're after, it's the direction we're heading.



Hyundai iLoad van shown in Creamy White

PEOPLE'S
CHOICE
Awards 2011

carsales.com.au
Australia's No.1 because it works!

PEOPLE'S
CHOICE
Awards 2010

carsales.com.au
Australia's No.1 because it works!

AUSTRALIA'S GUIDE TO LITES, VANS, LIGHT TRUCKS & PEOPLE MOVERS
DELIVERY

**BEST MEDIUM VAN OF
THE YEAR 2008**

AUSTRALIA'S GUIDE TO LITES, VANS, LIGHT TRUCKS & PEOPLE MOVERS
DELIVERY

**BEST VAN OF THE YEAR
2009**

 **ANCAP**
Rated ★ ★ ★ ★

The Hyundai iLoad van and crew van set a new benchmark in commercial flexibility, passenger & cargo functionality, performance and reliability. The Hyundai iLoad... a special delivery from Hyundai.

Hyundai iLoad van

A tough new contender

With a choice of the 3-seater van or 6-seater crew van with cargo compartment, Hyundai has created a highly-functional commercial vehicle that's as versatile and accommodating as it is robust and reliable.

The new Hyundai iLoad combines effortless practicality and precision engineering with advanced safety technology and enviable fuel economy in a mobile workplace that won't let you down. You can also select from a range of Genuine Hyundai Accessories to customise your Hyundai iLoad.

Load up your business... with the Hyundai iLoad



⁰¹ Versatility

⁰² Space

⁰⁴ Safety

⁰⁶ Comfort

⁰⁸ Power

¹⁰ Accessories
& Features

01

¹² Colours
& Finish

¹³ Specifications



When size matters...
Hyundai iLoad van delivers the goods.

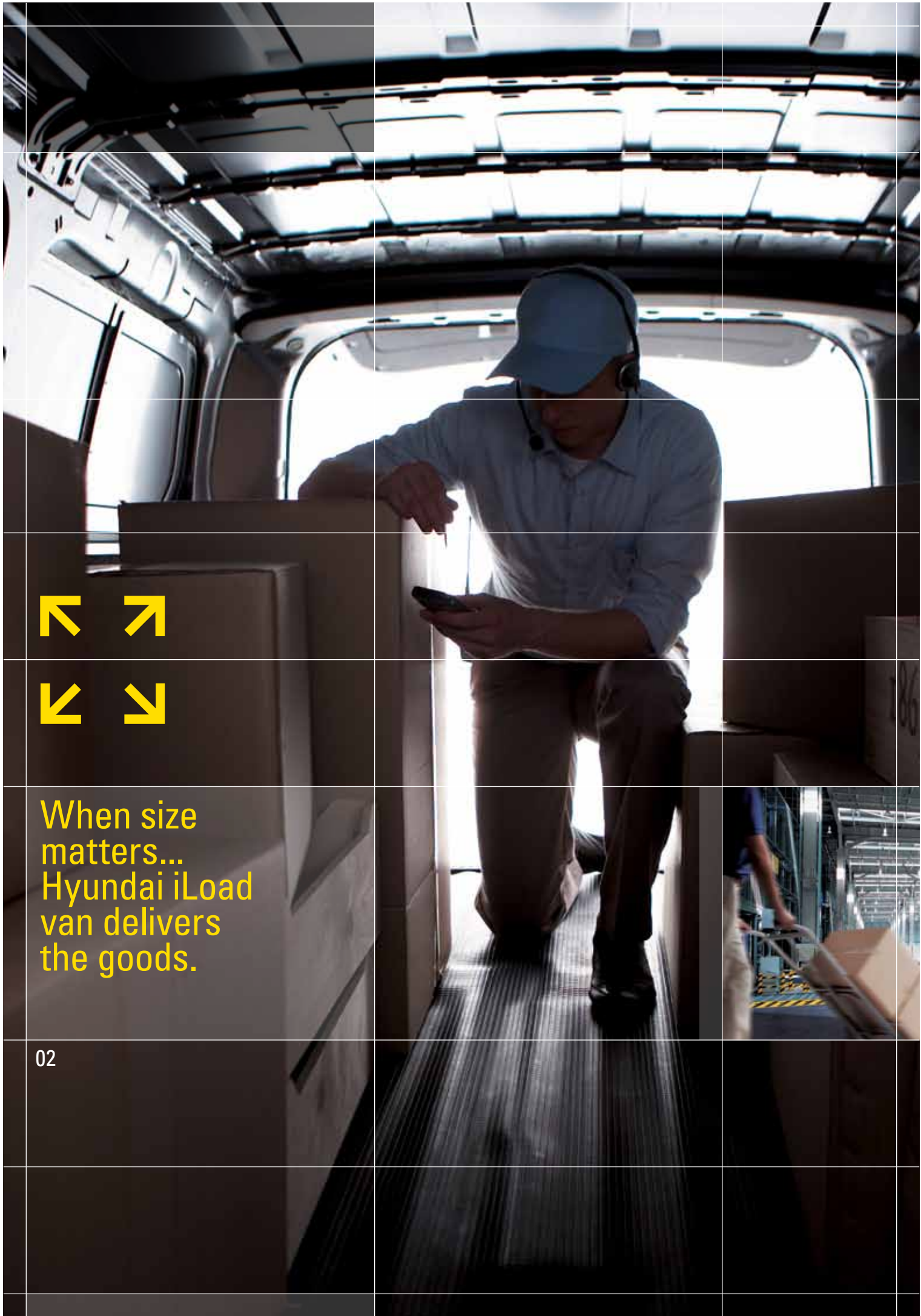

Room to Move

For operators requiring maximum carrying capacity, the 3 seater Hyundai iLoad van boasts plenty of usable cargo space (2.37m long, 1.68m wide and 1.35m high) large enough for two pallets, with a practical vinyl-covered flat floor.

Van functionality includes two sliding side doors as standard plus rear lift gate or optional twin swing doors for easy access, along with a collapsible centre seat that converts to additional storage when not needed for a third passenger.

For those wanting even more passenger space, Hyundai iLoad crew van provides seating for up to six people whilst retaining a generous cargo compartment with plenty of room for a pallet or delivery items.

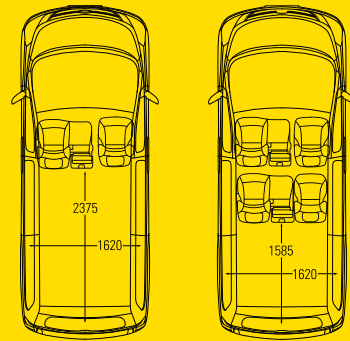

van

crew van

Space



Big on Safety

From the robust chassis and superior braking to the dual airbag system and seatbelt pretensioners, Hyundai iLoad's active and passive safety features further demonstrate Hyundai's commitment to driver, passenger and cargo protection at all times.



- 4 Star ANCAP safety rating
- 4-channel Anti-Skid Braking System (ABS) with Electronic Brakeforce Distribution (EBD) and 4 disc brakes (ventilated)
- Optional Electronic Stability Control (ESC) and Traction Control System (TCS) with CRDi models
- Dual front airbags and height-adjustable front seatbelts with pretensioner
- Keyless entry + immobiliser + security alarm + central locking
- Semi-bonnet design
- Floor to ceiling cargo intrusion barrier*
- Four-ring strengthened body with rigid cabin
- Impact absorbing crush zones front and rear

Protecting lives and your livelihood

Disc brakes (ventilated)

04

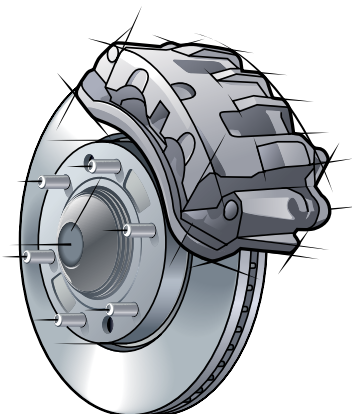

4 ring construction

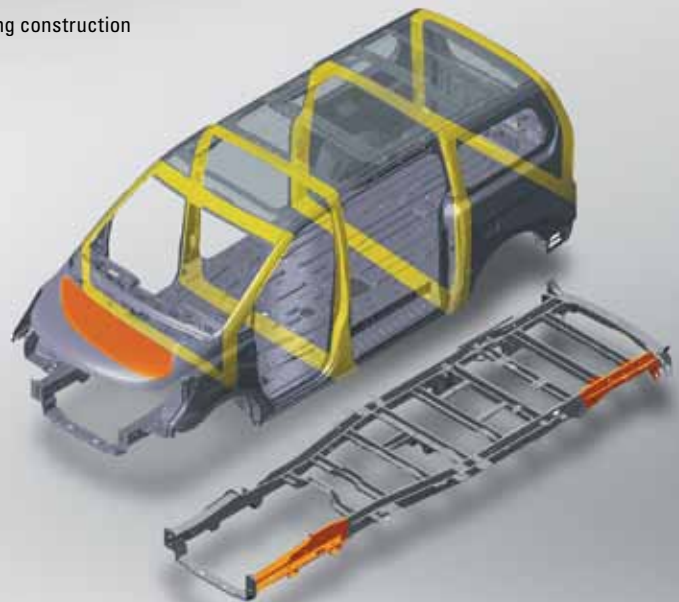

*Available on crew van only



Dual airbags



Shown with optional twin swing doors – 180° access

Cabin Comfort

Complementing the Hyundai iLoad's car-like steering and handling is a spacious, ergonomic and comfortable cabin where all controls are within easy reach. Driver and passenger comforts include air conditioning, power steering, power windows and mirrors, cup holder, tachometer and a quality audio system with Bluetooth®, iPod®, and MP3 player connectivity.

The tilt steering column and front console-mounted gearshift further emphasise the modern, functional layout and provide easier movement between driver and front passengers, and the high seating position, oversized windscreen and large door mirrors deliver optimum visibility. For cabin security, the van is equipped with keyless entry and an alarm with central locking. The driver's seat is height adjustable, the steering wheel can be tilted and there are even easy to reach grab handles to make entering and exiting a breeze.







Power

08

2.5 CRDi Diesel*

- Power = 100kW (manual), 125kW (auto)
- Torque = 343Nm (manual), 441Nm (auto)
- Fuel = 8 litres* (manual) per 100km
8.8 litres* (auto) per 100km
- Variable Geometry Turbo (VGT) for immediate throttle response and economy, and Common Rail Direct injection (CRDi) Diesel fuel delivery system

Towing Capacity:

Diesel manual – 2000kg (braked)
– 750kg (unbraked)

Diesel auto – 1500kg (braked)
– 750kg (unbraked)

2.4 CVVT petrol

- Power = 129kW
- Torque = 228Nm
- Fuel = 10.1 litres* (manual) per 100km
- Continuously Variable Valve Timing (CVVT) synchronises power with economy

Towing Capacity:

Petrol manual – 1500kg (braked)
– 750kg (unbraked)

*Australian Design Rule 81/02 static laboratory combined average city & highway cycle test. Fuel consumption will vary depending on a combination of driving habits and the condition of the vehicle.
• From February 2012 production.

Packaged to Perform

Engineered to handle the heaviest of loads, the Hyundai iLoad van tackles the most arduous of conditions with ease.

Macpherson strut front suspension and leaf spring rear suspension is positioned for optimal load-bearing, the 4-channel Anti-Skid Braking System (ABS) acts on ventilated front and rear discs with a 10" booster for exceptional stopping power; and the optional Electronic Stability Control (ESC)* with Traction Control System (TCS)* work together to monitor engine response and help control wheel slippage in hazardous braking circumstances.

The 2.4 petrol or high output 2.5 Diesel engines deliver outstanding power and torque, while advanced technology ensures enviable economy and dependability. A gutsy 6-speed manual transmission is applied as standard, with 5-speed automatic or 6-speed manual transmission also available in Diesel model.



2.5 CRDi turbo Diesel

2.4 CVVT petrol

*Diesel model only

Genuine Hyundai iLoad Accessories



Cargo Barrier (60kg rating)



Tailored Rubber Floor Mats
(Front cabin only)



Rubber Cargo Mat⁶



Sliding Door Windows (Fixed)



Grab Handles



Tinted Stylevisors (Front pair only)



Towbar & Towball and
Trailer Wiring Harness¹



Rear Step with Corner Protectors⁴



Reverse Park Assist (4 head)³



Courier's Wooden Floor



Technician Step with Grab Handles
(Towbar required)⁴



Full Technician Kit^{2,5}

AUSTRALIA'S FIRST

5 YEAR UNLIMITED KM WARRANTY

Genuine Hyundai Accessories for all Hyundai iLoad vans, Hyundai iLoad crew vans and Hyundai iMax shuttles are covered by Australia's First 5-year/Unlimited Kilometre Accessories Warranty.

All Genuine Hyundai Accessories are subject to warranty conditions. See your nearest Hyundai Dealer or visit our website at hyundai.com.au for full warranty terms and usage recommendations. Accessories pictured are all sold separately at an additional cost.



Hyundai iLoad 3 seat 2.4 litre petrol is accessorised with: Full Technician Kit, Roof Rack (3 bar set), Headlight Protectors and Tinted Stylevisors (Front pair only). All sold separately at additional cost.

1. Maximum ball download 150kg. Towbar (1500kg braked & 750kg unbraked – petrol and CRDi automatic) or (2000kg braked & 750kg unbraked – or with CRDi manual). Towbar capacity subject to regulatory requirements, Towbar design, vehicle design and towing equipment limitations. 2. Includes Ladder Holders, Conduit Holder, Key Locking Security Cables & Worklight Mount. Load Capacity = 125kg evenly distributed across 3 bars with secure lock function. 3. Park Assist Sensors are designed as driver assist function only and should not be used as a substitute for skilled driving and safe parking practices. The area into which the vehicle is heading must be visually monitored by the driver while parking. 4. Towbar Required. Maximum ball download 150kg. 5. Roof Racks (3 Bar Set) Required. 6. Compatible for use with anchor mounts and cargo barrier. 7. Bluetooth v2.0 supports Hands Free Profile (HFP) v1.5, Object Push Profile (OPP) v1.0, Advanced Audio Distribution Profile (A2DP) v1.0 and Audio/Video Remote Control Profile (AVRCP). Bluetooth® is a registered trademark of Bluetooth SIG, Inc. 8. iPod® is a registered trademark of Apple computer Inc., registered in the U.S. and other countries.

Hyundai iLoad Features



ESC + TCS option



Ventilated disc brakes with ABS and EBD



Dual airbags



Seatbelt pretensioners and height adjustable seatbelts



Keyless entry with burglar alarm



6 Seat crew van



Tilt steering column
Steering wheel audio controls



Rear glass demister & rear wiper



Power windows and mirrors



Bluetooth® media streaming and Handsfree*



Aux & USB with iPod® connectivity⁸



Cup and bottle holders



Air conditioning



Dual glovebox compartments



Twin front door pockets



Tachometer



Rear wheel drive



Tie down hooks



2.4L petrol (manual)



2.5L CRDi turbo diesel (manual & auto)



Two sliding doors for easy access



Optional twin swing doors



Vinyl cargo area floor covering



Height adjustable seats

Hyundai iLoad Colours & Finish

					Super Red*
					Horizon Blue
					Dynamic Yellow*
					Blue Sapphire*
					Creamy White
					Timeless Black



Hyundai iLoad van shown in Creamy White

12					Magnetic Grey
					Hyper Metallic
					*special order



Hyundai iLoad van

Hyundai iLoad crew van

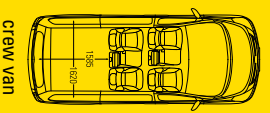
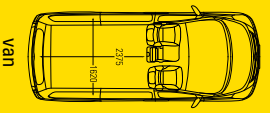

Hyundai iMax shuttle

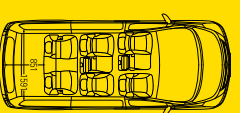



Genuine Hyundai Parts

Not all parts are equal, insist on Genuine Hyundai Parts.

The quality and reliability of Hyundai products are key factors in your purchasing decision. Through careful design and engineering, Hyundai automobiles are built to provide you with years of worry free driving enjoyment with minimum maintenance.

For your peace of mind remember that Hyundai Genuine Parts are backed by a 12 month, 20,000 km warranty in order to provide high-quality service and maintenance.

Hyundai iLoad Confidence

Hyundai builds each and every vehicle using state-of-the-art technology to meet the world's highest quality standards. This is evidenced by the fact that the company now delivers Australia's first 5 year / 160,000km warranty on all new Hyundai iLoad commercial vehicles. It is only because of our belief in the research and development behind every vehicle's design, the exceptional quality of materials and workmanship used in manufacturing, pre-delivery testing and an outstanding dealer network that Hyundai can back its product without any qualms, offering you complete confidence and peace of mind. There's also the additional support of 12 months roadside assistance in case of vehicle immobility such as running out of fuel.



Hyundai iMax Confidence

Hyundai builds each and every vehicle using state-of-the-art technology to meet the world's highest quality standards. This is evidenced by the fact that the company now offers Australia's First 5 Year Unlimited Kilometre Factory Warranty* on all new Hyundai iMax vehicles as a standard promise of excellence. It is only because of our belief in the research and development behind every vehicle's design, the exceptional quality of materials and workmanship used in manufacturing, pre-delivery testing and an outstanding dealer network that Hyundai can back its product without any qualms, offering you complete confidence and peace of mind. There's also the additional support of 12 months roadside assistance in case of vehicle immobility such as running out of fuel.



*Note: The warranty extension to Unlimited Kilometres is only applicable to vehicles used for private and domestic uses and is not applicable to vehicles used for certain high mileage commercial purposes, i.e. Courier, Security and Rental Cars.

The Right Balance for your Business

If you're serious about:

- Selecting the right vehicle for your business
- Reducing your fleet's environmental impact
- Reducing your fleet's whole of life costs
- Providing a safer environment for your greatest assets, your employees

Make the right business decisions not the same decisions you've always made – consider the Hyundai Fleet Advantage!



Hyundai Motor Company Australia Pty Ltd 394 Lane Cove Road, Macquarie Park, NSW Australia 2113 Hyundai Motor Company (HMC) and the Hyundai Motor Company Australia (HMCA) each reserve the right to alter vehicle specifications and equipment levels without notice. Some equipment featured on the cars in this brochure may not be available in Australia or may be optional. To the extent permitted by the law, neither HMC nor HMCA shall be liable to any person as a result of reliance on the content of this brochure. Please consult your Hyundai dealer for the latest specifications, equipment levels, options, prices, colours and vehicle availability. Metallic and mica paint are optional extras. Note: Information in this brochure is current as at 04/05/2012. **Part No. TQ0512B.**

