

HYUNDAI | NEW THINKING.
NEW POSSIBILITIES.

iLoad van



Hyundai iLoad van

A tough new contender

With a choice of the 3-seater van or 6-seater crew van with cargo compartment, Hyundai has created a highly-functional commercial vehicle that's as versatile and accommodating as it is robust and reliable.

The Hyundai iLoad combines effortless practicality and precision engineering with advanced safety technology and enviable fuel economy in a mobile workplace that won't let you down. You can also select from a range of Hyundai Genuine Accessories to customise your Hyundai iLoad.

Load up your business...with the Hyundai iLoad

⁰¹ Versatility

⁰² Space

⁰⁴ Safety

⁰⁶ Comfort

⁰⁸ Power

¹⁰ Accessories
& Features

01

¹² Colours
& Finish

¹³ Specifications



When size matters...
Hyundai iLoad
van delivers
the goods.



Room to Move

For operators requiring maximum carrying capacity, the 3 seater Hyundai iLoad van boasts plenty of usable cargo space (2.37m long, 1.62m wide and 1.35m high) large enough for two pallets, with a practical vinyl-covered flat floor.

Van functionality includes two sliding side doors as standard plus rear lift gate or optional twin swing doors (Diesel only) for easy access, along with a collapsible centre seat that converts to additional storage when not needed for a third passenger.

For those wanting even more passenger space, Hyundai iLoad crew van provides seating for up to six people whilst retaining a generous cargo compartment with plenty of room for a pallet or delivery items.

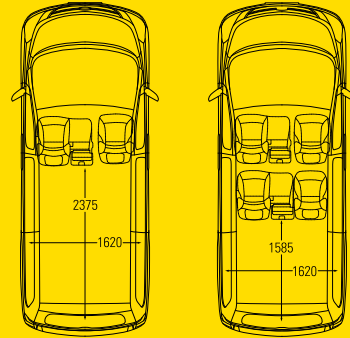

van

crew van

Space



Big on Safety

From the robust chassis and superior braking to the dual airbag system and seatbelt pretensioners, Hyundai iLoad's active and passive safety features further demonstrate Hyundai's commitment to driver, passenger and cargo protection at all times.

- 4-Star ANCAP safety rating
- 4 channel Anti-skid Braking System (ABS) with Electronic Brakeforce Distribution (EBD) and 4 disc brakes (ventilated)
- Electronic Stability Control (ESC) and Traction Control System (TCS) with CRDi models
- Dual front airbags and height-adjustable front seatbelts with pretensioner
- Keyless entry + immobiliser + security alarm + central locking
- Semi-bonnet design
- Four-ring strengthened body with rigid cabin
- Impact absorbing crush zones front and rear



ANCAP
Safety ★★★★★

Protecting lives and your livelihood

Disc brakes (ventilated)

04

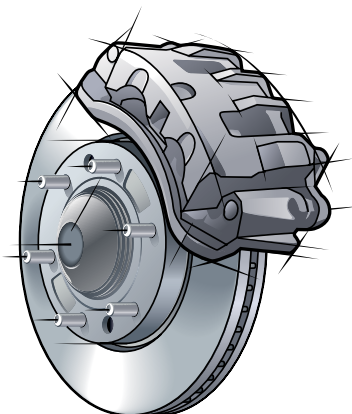

4 ring construction

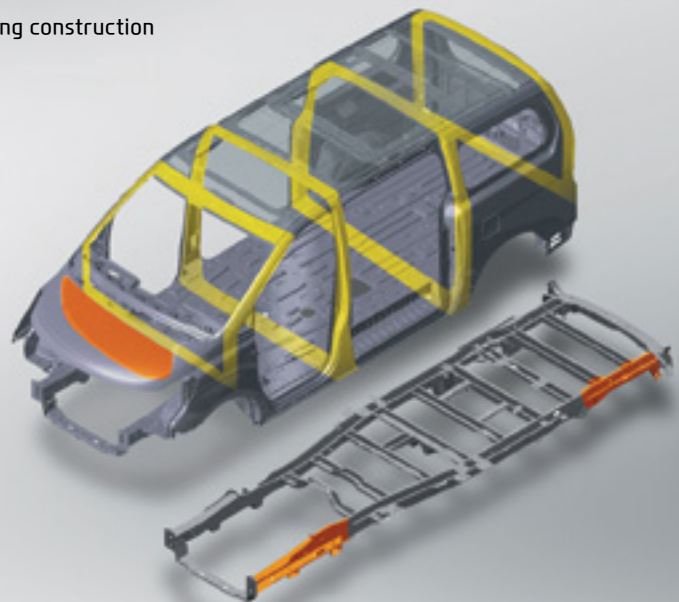

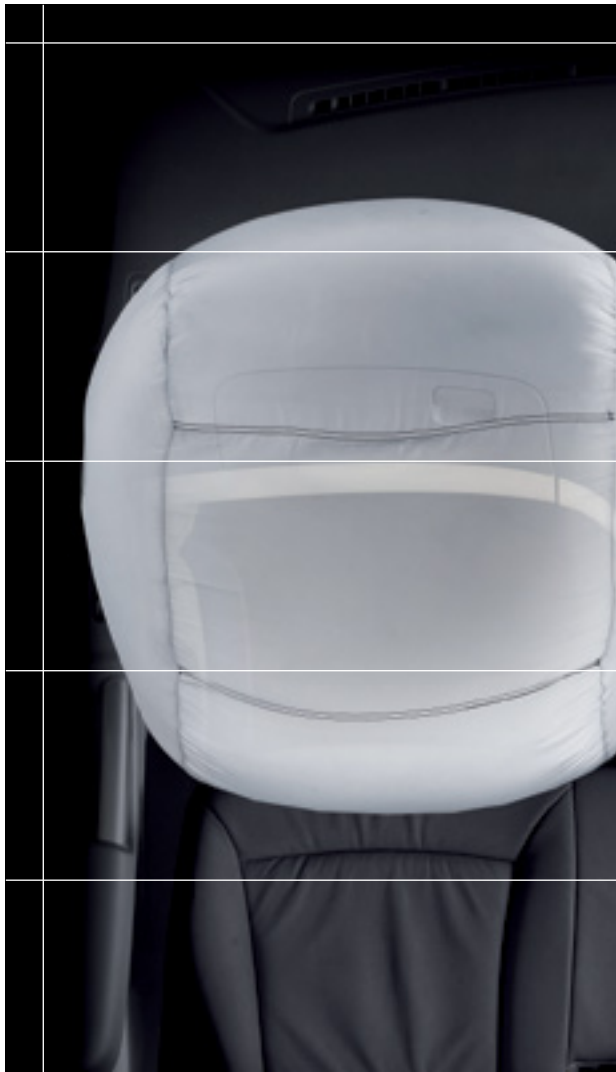

Dual airbags



Shown with optional twin swing doors - 180° access

Cabin Comfort

Complementing the Hyundai iLoad's car-like steering and handling is a spacious, ergonomic and comfortable cabin where all controls are within easy reach. Driver and passenger comforts include air conditioning, power steering, power windows and mirrors, cup holder, tachometer and a quality audio system with Bluetooth,[#] iPod,[^] and MP3 player connectivity.

The tilt steering column and front console-mounted gearshift further emphasise the modern, functional layout and provide easier movement between driver and front passengers, and the high seating position, oversized windscreen and large door mirrors deliver optimum visibility. For cabin security, the van is equipped with keyless entry and an alarm with central locking. The driver's seat is height adjustable, the steering wheel can be tilted and there are even easy to reach grab handles to make entering and exiting a breeze.



Bluetooth[®] is a registered trademark of Bluetooth SIG, Inc. [#]Please check your Bluetooth[®] device's capabilities to ensure compatibility. iPod[®] is a registered trademark of Apple Inc., registered in the US and other countries. [^]iPod[®] and connection lead not included.





Power

2.5 CRDi Diesel*

- Power = 100kW (manual), 125kW (auto)
- Torque = 343Nm (manual), 441Nm (auto)
- Fuel = 8 litres* (manual) per 100km
8.8 litres* (auto) per 100km
- Variable Geometry Turbo (VGT) for immediate throttle response and economy, and Common Rail Direct injection (CRDi) Diesel fuel delivery system

Towing Capacity:

Diesel manual - 2000 kg (braked)
- 750 kg (unbraked)

Diesel auto - 1500 kg (braked)
- 750 kg (unbraked)

*Australian Design Rule 81/02 static laboratory combined average city & highway cycle test. Fuel consumption will vary depending on a combination of driving habits and the condition of the vehicle. • From February 2012 production.

2.4 CVVT petrol

- Power = 129kW
- Torque = 228Nm
- Fuel = 10.1 litres* (manual) per 100km
- Continuously Variable Valve Timing (CVVT) synchronises power with economy

Towing Capacity:

Petrol manual - 1500 kg (braked)
- 750 kg (unbraked)

Packaged to Perform

Engineered to handle the heaviest of loads, the Hyundai iLoad van tackles the most arduous of conditions with ease.

Macpherson Strut front suspension and leaf spring rear suspension is positioned for optimal load-bearing, the 4-channel Anti-skid Braking System (ABS) acts on ventilated front and rear discs with a 10" booster for exceptional stopping power; and the optional Electronic Stability Control (ESC)* with Traction Control System (TCS)* work together to monitor engine response and help control wheel slippage in hazardous braking circumstances.

The 2.4 petrol or high output 2.5 Diesel engines deliver outstanding power and torque, while advanced technology ensures enviable economy and dependability. A gutsy 6-speed manual transmission is applied as standard, with 5-speed automatic or 6-speed manual transmission also available in Diesel model.



2.5 CRDi turbo Diesel



2.4 CVVT petrol

*Diesel model only

Hyundai Genuine Accessories

Hyundai Genuine Accessories can enhance your driving pleasure and ownership pride by adding extra ease and enjoyment to your lifestyle pursuits. Importantly, Hyundai Genuine Accessories are an astute way to help keep your new iLoad in original showroom condition.

All Hyundai Genuine Accessories are backed by a 5 year warranty if purchased at the time of a new Hyundai vehicle and fitted by an authorised Hyundai dealer.*



Cargo Barrier



Tailored Rubber Floor Mats



Rubber Cargo Mat



Sliding Door Windows



16" Alloy Wheels (sold singularly – tyres not included)

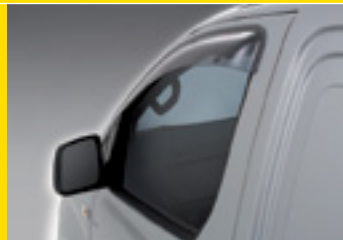

Tinted Stylevisors



Towbar & Towball and Trailer Wiring Harness¹



Rear Step with Corner Protectors



Rear Park Assist²



Courier's Wooden Floor



Technician Step with Grab Handles



Full Technician Kit³



Seat Covers (sold singularly)



Headlight Protectors



Dash Mat



Grab Handles

Images used for illustrative purposes only. 1. Maximum ball download 150kg. Towbar (1500kg braked & 750kg unbraked – petrol and CRDI automatic) or (2000kg braked & 750kg unbraked – CRDI manual). Towbar capacity subject to regulatory requirements, towbar design, vehicle design and towing equipment limitations. 2. Park Assist is designed as driver assist aid only and should not be used as a substitute for skilled driving and safe parking practices. While the Park Assist sensors monitor objects on approach, there may be occasions where blind spots affect the sensitivity of the sensors and as a result the area into which the vehicle is heading must be visually monitored by the driver at all times while parking. 3. Load capacity = 125kg evenly distributed across 3 bars with secure lock function.

* All Hyundai Genuine Accessories are subject to warranty conditions. See your nearest Hyundai Dealer or visit our website at www.hyundai.com.au for full warranty terms and usage recommendations. Accessories pictured are all sold separately at an additional cost.

5 YEAR ACCESSORIES WARRANTY

HYUNDAI | Genuine Accessories



The iLoad featured above is accessorised with a Full Technician Kit³, Commercial Roof Racks (3 bar set)³, Headlight Protectors (set of 2), Tinted Stylevisors (set of 2), Towbar, Towball & Trailer Wiring Harness¹, Technician Step, 16" Alloy Wheels (sold singularly), Sliding Door Windows and Alloy Nudge Bar. All sold separately at additional cost. Images used for illustrative purposes only.

Hyundai iLoad Colours & Finish

Exterior Colour

Creamy White
(YAC) - Solid

Timeless Black
(RB5) - Mica

Hyper Metallic
(P2S) - Metallic

Interior Colour

Tricott Suede / Grey

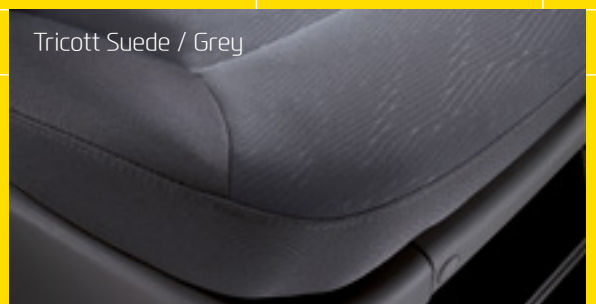

Colours are indicative only and may vary due to the printing process. Metallic and Mica paint are optional extras.

Hyundai iLoad Features



ESC + TCS option



Ventilated disc brakes with ABS and EBD



Dual airbags



Seatbelt pretensioners and height adjustable seatbelts



Keyless entry with burglar alarm



6 Seat crew van



Tilt steering column
Steering wheel audio controls



Rear glass demister & rear wiper



Power windows and mirrors



Bluetooth® media streaming and Handsfree¹



Aux & USB with iPod® connectivity²



Cup and bottle holders



Air conditioning



Dual glovebox compartments



Twin front door pockets



Tachometer



Rear wheel drive



Tie down hooks



2.4L petrol (manual)



2.5L CRDi turbo Diesel (manual & auto)



Two sliding doors for easy access



Optional twin swing doors



Vinyl cargo area floor covering



Height adjustable seats

1. Bluetooth® is a registered trademark of Bluetooth SIG, Inc. Please check your Bluetooth® device's capabilities to ensure compatibility. 2. iPod® is a registered trademark of Apple Inc., registered in the U.S. and other countries.



Hyundai iLoad van

Hyundai iLoad crew van

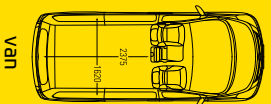

VAN

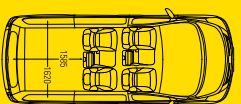

CREW VAN

Hyundai iMax shuttle

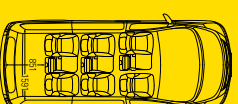

Hyundai Genuine Parts

Whenever you buy a Hyundai Genuine Part you can be confident that you're buying the best for your vehicle, and your family. Not only are Hyundai Genuine Parts specifically designed to meet Australian Design Rules, and made to the highest standards, they're also tested to withstand a wide range of extreme conditions and backed by a 12 month 20,000 km warranty*, so they're:

- Guaranteed to fit
- Guaranteed to perform
- Guaranteed to last



Hyundai iLoad Confidence

Hyundai builds each and every vehicle using state-of-the-art technology to meet the world's highest quality standards. This is evidenced by the fact that the company now delivers Australia's first 5 year / 160,000km warranty on all new Hyundai iLoad commercial vehicles. It is only because of our belief in the research and development behind every vehicle's design, the exceptional quality of materials and workmanship used in manufacturing, pre-delivery testing and an outstanding dealer network that Hyundai can back its product without any qualms, offering you complete confidence and peace of mind. There's also the additional support of 12 months roadside assistance in case of vehicle immobility such as running out of fuel.



Hyundai iMax Confidence

Hyundai builds each and every vehicle using state-of-the-art technology to meet the world's highest quality standards. This is evidenced by the fact that the company now offers Australia's First 5 Year Unlimited Kilometre Factory Warranty* on all new Hyundai iMax vehicles as a standard promise of excellence. It is only because of our belief in the research and development behind every vehicle's design, the exceptional quality of materials and workmanship used in manufacturing, pre-delivery testing and an outstanding dealer network that Hyundai can back its product without any qualms, offering you complete confidence and peace of mind. There's also the additional support of 12 months roadside assistance in case of vehicle immobility such as running out of fuel.



*Note: The warranty extension to Unlimited Kilometres is only applicable to vehicles used for private and domestic uses and is not applicable to vehicles used for certain high mileage commercial purposes, i.e. Courier, Security and Rental Cars.

The Right Balance for your Business

If you're serious about:

- Selecting the right vehicle for your business
- Reducing your fleet's whole of life costs
- Reducing your fleet's environmental impact
- Providing a safer environment for your greatest assets, your employees

Make the right business decisions not the same decisions you've always made - consider the Hyundai Fleet Advantage!



Hyundai Motor Company Australia Pty Ltd 394 Lane Cove Road, Macquarie Park, NSW Australia 2113 Hyundai Motor Company (HMC) and the Hyundai Motor Company Australia (HMCA) each reserve the right to alter vehicle specifications and equipment levels without notice. Some equipment featured on the cars in this brochure may not be available in Australia or may be optional. To the extent permitted by the law, neither HMC nor HMCA shall be liable to any person as a result of reliance on the content of this brochure. Please consult your Hyundai dealer for the latest specifications, equipment levels, options, prices, colours and vehicle availability. Metallic and mica paint are optional extras. Note: Information in this brochure is current as at 21/03/2014. HMCAT134 **Part No. T00514B**

HYUNDAI NEW THINKING. NEW POSSIBILITIES.

At Hyundai, we understand that life is about continual change. Our progress as a company isn't measured by our actions in the past but by how we respond to our environment and listen to our customers.

Our focus today is on producing cars that embody quality, variety, innovation and individuality... cars that are underpinned by 5-Star quality in design, build, features, accessories and safety. And as a testament to our worldwide commitment to quality, Hyundai is now one of the world's fastest growing automotive brands.

Our aim is to challenge and question the way things are done to create bigger new ideas and better quality solutions to enrich our customers' life experiences. Only by re-imagining what tomorrow's world will bring, can we meet our customers' needs now and into the future. We invite you to join us on our journey.

A NEW BENCHMARK IN SERVICE AND SUPPORT

Along with your iLoad van purchase, we offer you all the benefits of the award-winning Hyundai iCare program. It's part of our commitment to back every vehicle we build, so that your Hyundai ownership is an enjoyable, worry-free experience. iCare includes:

- The peace-of-mind of a 5 year 160,000 kilometre warranty
- Hyundai iCare Capped Price Service[#], which further reduces the cost of owning a Hyundai
- The confidence of Hyundai Roadside Assist for up to 7 years*
- The convenience and exclusive benefits of myHyundai
- The support of our 24/7 Customer Care Centre
- The assurance of a complimentary 1,500km vehicle inspection
- The satisfaction of having your vehicle serviced by qualified Hyundai factory-trained technicians using only Hyundai Genuine Parts
- The timeliness of updated mapping and content for factory installed satellite navigation through the 3 years NAVTEQ MapCare™ Plan[^]



Hyundai iLoad van shown in Creamy White

The Hyundai iLoad van and crew van set a new benchmark in commercial flexibility, passenger & cargo functionality, performance and reliability. The Hyundai iLoad...a special delivery from Hyundai.

iCare Terms

***12 months free Roadside Assist:** Complimentary 12 months Roadside Assist when you purchase a new Hyundai vehicle (excluding rental buyers). Roadside Assist extensions are valid for 12 months from the date of scheduled maintenance service at a participating authorised Hyundai dealer. Does not apply to vehicles when they reach 84 months from original new car sale date. **^MapCare™:** MapCare™ Plan only applies to new vehicles with factory-fitted satellite navigation. NAVTEQ and MapCare™ are registered trademarks of Nokia Corporation. Maximum number of 2 updates, delivered on an annual cycle within 3 years of the vehicle's initial purchase. Free map updates only apply if the vehicle is serviced at a participating authorised Hyundai dealer. **#Capped Price Service:** Applies to new Hyundai vehicles first registered from 1/8/12, private and nominated small business customers only, for the first 3 years/45,000km, whichever comes first. Vehicles sold to rental, government, not-for-profit and fleet customers are not eligible. Eligible vehicles entitled to capped (maximum) price for standard scheduled maintenance (ie, logbook) services at participating authorised Hyundai dealers. **Terms and conditions apply to all warranty and Hyundai iCare offers, visit www.hyundai.com.au/icareterms for full terms, conditions, exclusions and eligibility details.**