

TECHNICAL BULLETIN



Automatic Transmission – Engine Stalls When Engaging “R” or “D” – Repair Procedure

44-23

MODEL All 4.0L with Auto Trans

DATE 12/94

ISSUE:

The engine stalls when the transmission is shifted to Reverse or Drive from Park. Stalling is most likely to occur when the engine is cold.

A restricted control unit oil seal in the transmission housing or a sticking torque converter control valve in the valve body may cause partial engagement of the torque converter clutch. Either of these conditions may cause the engine to stall.

ACTION:

If 4.0L vehicles equipped with automatic transmissions stall when shifting into Drive or Reverse from Park, follow the procedure outlined below.

DIAGNOSTIC PROCEDURE

1. Verify engine setup using JDS/PDU
2. Verify transmission fluid level and condition
3. Interrogate the TCM for DTCs

If the engine setup and transmission fluid are within specification and no DTCs are present, perform the procedure appropriate to the mileage of the vehicle.

VEHICLES WITH LESS THAN 1000 MILES – REPAIR PROCEDURE

1. Remove the transmission valve body following the instructions in the Service Manual, section 44.2 (R.O. number 44.40.01).
2. Remove the control unit oil seal (part number JLM 863) shown in Illustration 1.

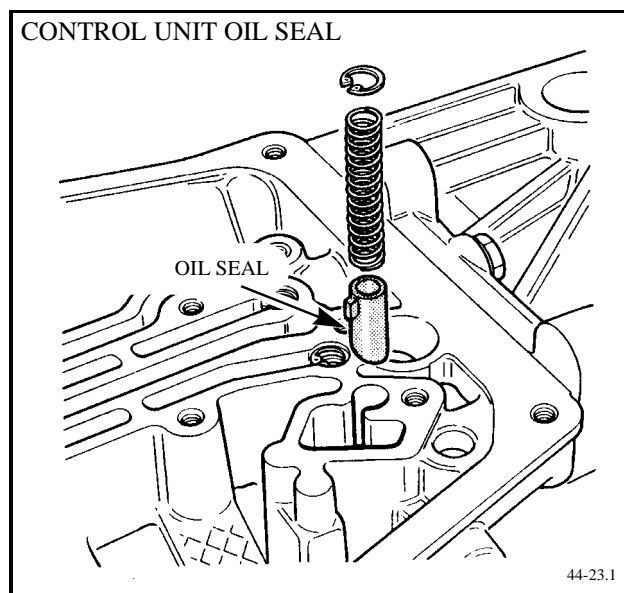

ILLUSTRATION 1

CAUTION: If the seal is incorrectly fitted or restricted, the lockup clutch may partially engage causing the engine to stall.

3. Install a new control unit oil seal
4. Reassemble the transmission following the instructions in the Service Manual.

VEHICLES WITH MORE THAN 1000 MILES – REPAIR PROCEDURE

1. Remove the transmission valve body following the instructions in the Service Manual, section 44.2 (R.O. number 44.40.01).
2. Remove the torque converter control valve from the valve body (Illustration 2).

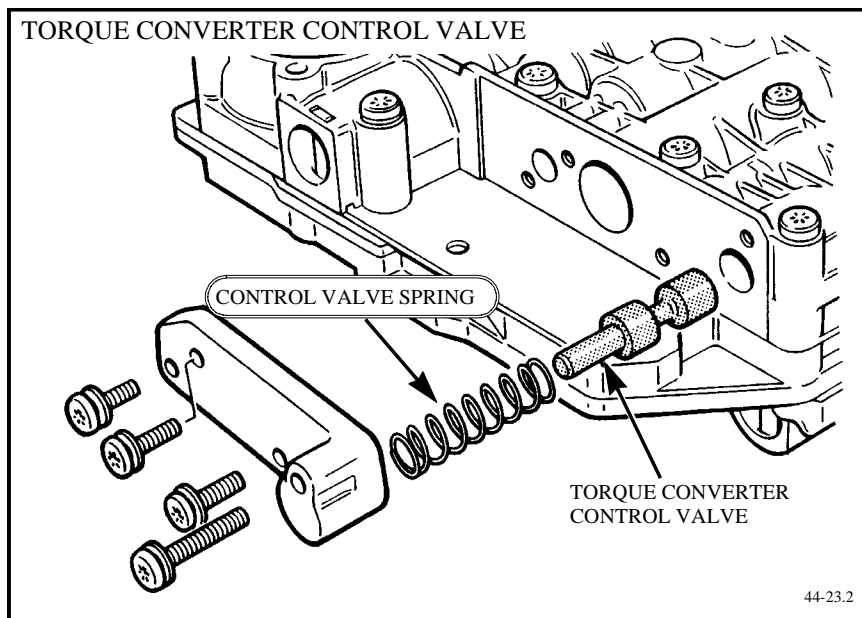

ILLUSTRATION 2

3. Clean the valve and valve bore. The valve must slide freely in the bore.
4. Refit the control valve using a new spring (part number JLM 11573).
5. Install the valve body.

NOTE: Torque the valve body securing screws to 6 lb ft (8 Nm).

6. Install a new transmission oil filter and reassemble following the instructions in the Service Manual.

PARTS INFORMATION:

<u>DESCRIPTION</u>	<u>PART NUMBER</u>
Transmission oil filter (XJS)	JLM 664
Transmission oil filter (Sedan Range)	JLM 2128
Control unit oil seal	JLM 863
Spring - Torque converter control valve	JLM 11573

WARRANTY INFORMATION:

<u>FAULT CODE</u>	<u>R.O. NUMBER</u>	<u>DESCRIPTION</u>	<u>TIME ALLOWANCE</u>
FG FB CR	44.91.10	Automatic transmission - torque converter clutch - stalling	1.75 hrs.