



JAGUAR XK

# C O N T E N T S



DESIGN

6 - 9



ALUMINIUM

10 - 11



ENGINES

12 - 17



DETAIL  
22 - 25



RESPONSIBLE  
32 - 33



XKR-S  
34 - 39

# THE XK

Power, style and uncompromised luxury; the XK epitomises Jaguar's legendary talent for creating beautiful high performance vehicles. A grand tourer with the heart and soul of a sports car, the XK builds on Jaguar's reputation for stunning design with its contemporary fusion of dramatic sweeping curves and a low-riding profile.

The range comprises three models – XK, XKR and XKR-S. Each is formed from aluminium, for a unique combination of lightness, strength and agility, and propelled by Jaguar's highly acclaimed 5.0 Litre V8 or 5.0 Litre V8 Supercharged engine. Together they offer a unique combination of sporting luxury, and the promise of an exhilarating driving experience that's designed to be exceptional.







## DESIGN

The XK possesses all of Jaguar's classic design motifs – seduction, power, elegance – conceived with a modern contemporary edge. Its sleek styling and sculpted athletic lines embody the spirit of performance, perfectly matching the car's sporting prowess. The XK's exterior details are built to reflect its dynamic capabilities, from its muscular rear haunches and distinctive horizontal chrome side vents to the dramatic front sub-wing air intakes. New, slimmer, bi-function HID Xenon headlamps are lined with LED daytime running lights and create a striking and distinctive visual signature. The XK is eye-catching, head turning, breathtaking.







# CONVERT

XK Convertible models combine the thrill of open top driving with uncompromised handling and comfort. Opening and stowing in just eighteen seconds, the roof folds itself neatly beneath a striking aluminium tonneau fitting seamlessly flush within the body – reducing buffeting at speed and compact enough to retain the XK's iconic shape. The triple layer roof, laminated to provide a taut and waterproof outer coat, incorporates innovative ultra-thin insulation material to deliver outstanding protection from weather, wind and road noise.





# ALUMINIUM

The XK's all-aluminium body construction is fundamental to the way the car performs. Using technology derived from the aerospace industry, it delivers a combination of lightness, strength and rigidity – the key to great sports car handling, superb performance and impressive efficiency. High torsional rigidity delivers exceptional agility, reduced body roll and pin-sharp cornering.

Jaguar's 5.0 Litre AJ-V8 GEN III engine delivers heart-racing acceleration and effortless power. It employs state-of-the-art engineering technologies to maximise its performance and refinement. Spray-guided direct injection optimises air to fuel ratios, while Cam Profile Switching adapts cam periods, depending on power requirements, giving up to 10 percent more mid-range torque. Dual Independent Variable Cam Timing recycles residual waste gases lowering emissions and improving fuel economy.



8

3

# 5 L I T R E

NATURALLY ASPIRATED

5.0 V8 PETROL

POWER – 283kW @ 6,500rpm

0-100kph SECONDS – 5.5

TOP SPEED – 250kph limited

COMBINED l/100km – 11.2

CARBON DIOXIDE EMISSIONS g/km – 264

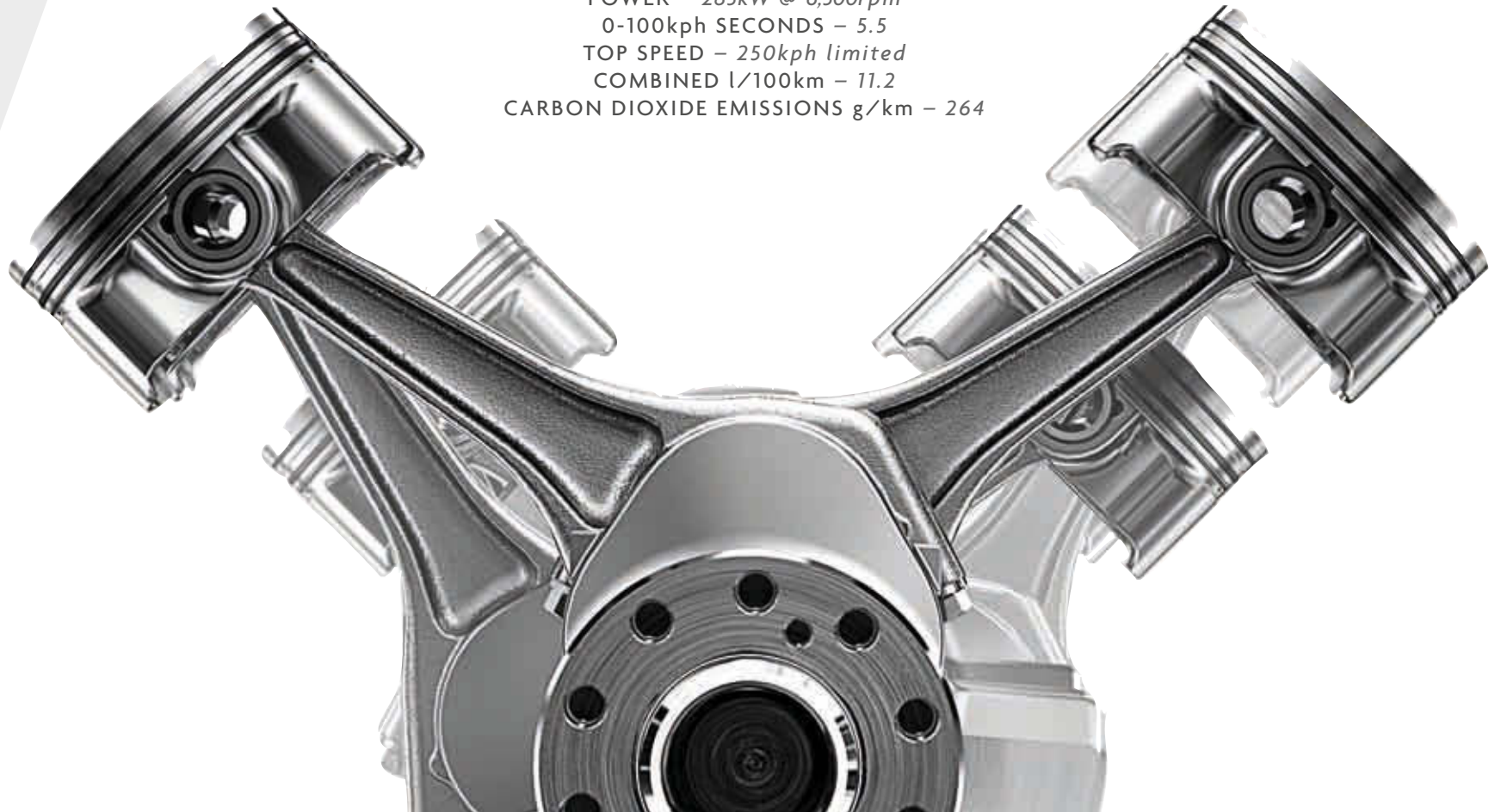

# P E R F O R M A N C E

The XKR re-defines the sporting capabilities of the XK, re-engineered and recalibrated, updated and enhanced – making a great car even greater and taking XK dynamic performance to another level. At the heart of the XKR is Jaguar's acclaimed 5.0 AJ-V8 GEN III Supercharged engine. This all-aluminium quad-cam powerplant produces 375kW with seamless power delivery and tremendous torque – up to 625Nm. XKR symbolises the intensifying of the sporting experience, delivering the sublime luxury of a grand tourer with the passion and muscle of a thoroughbred champion.





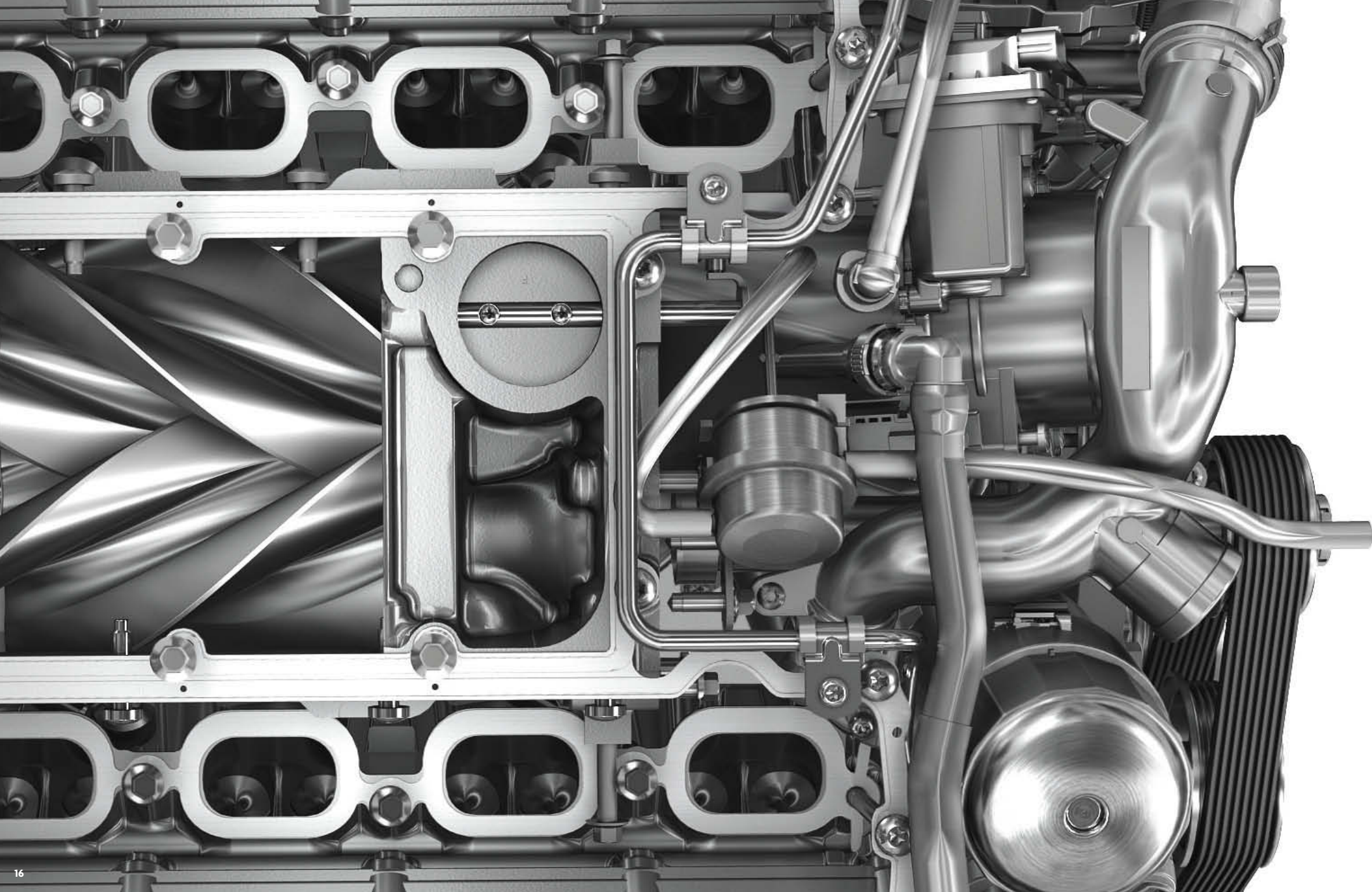



# V8

## 5 LITRE

### SUPERCHARGED

5.0 LITRE V8 SUPERCHARGED  
POWER – 375kW @ 6,000-6,500rpm  
0-100kph SECONDS – 4.8  
TOP SPEED – 250kph limited  
COMBINED l/100km – 12.3  
CARBON DIOXIDE EMISSIONS g/km – 292







# R E W A R D

At every turn the XK rewards the driver with involving, outstanding driving dynamics. With its aluminium monocoque bodyshell providing exceptional torsional stiffness, it offers precise handling and fine body control.

All models employ an array of intelligent adaptive technologies designed to assist but never overwhelm. The Servotronic 2 steering system provides support to improve manoeuvring at low speeds but reduces assistance at higher speeds. The ZF 6HP28 6-speed automatic transmission reads individual driving styles and the road environment to constantly adapt its gear shift pattern. It is designed to optimise fuel efficiency while anticipating and preparing to provide the instant power that high speed manoeuvring or overtaking may require. It works in conjunction with Dynamic Stability Control which intervenes in demanding driving situations by applying braking to individual wheels where necessary, reducing engine torque and helping to maintain stability in challenging driving conditions.

JaguarDrive Control™ offers the driver the opportunity to select different modes to suit their driving preference or the prevailing conditions. Dynamic mode delivers even more responsive acceleration for a thrilling sporting experience. Winter mode dampens the accelerator pedal response to help reduce the risk of spin and maintain progressive wheel control in slippery conditions. Its bespoke shift settings delay and soften gear shifts for better control with low grip.



## SMOOTHING OUT THE CURVES

XK features a range of innovative and advanced driving technologies designed to complement the driver and enhance the drive. Adaptive Dynamics continuously monitors the car's speed, steering and body movements, analysing the suspension response and varying the damping to suit the conditions, whether cornering, navigating uneven surfaces or accelerating on an open road. The system calculates the appropriate suspension response 500 times every second keeping the vehicle flat, stable and secure allowing confident, precise handling without any loss of ride comfort.

With its higher performance capabilities the XKR demands even greater agility and control. The Active Differential works together with the XKR's traction, ABS and Dynamic Stability Control to analyse the firmness of the road surface. It adjusts the differential of each wheel to optimise traction on loose surfaces, and sharpen the car's agility through bends.





# DETAIL

Jaguar selects the finest materials to create interiors that are finished to the most luxurious standards. Classic textures are combined with modern styling, flawless craftsmanship and signature phosphor blue mood lighting in a cabin that is elegant, contemporary and driver-focused. Leather features extensively, along with hand-crafted wood, Piano Black or technical finish veneers and smooth chrome. The wide selection of colours, materials and veneers offer the opportunity for personalisation and individuality, whilst unique choices such as optional Poltrona Frau® leather headlining can provide the perfect finishing touch.





# LUXURY

Two seat styles are available, each with detailed finishing and a comprehensive range of colour choices. Luxury seats upholstered in soft grain leather are standard in the XK. They feature heating and cooling, 16-way power adjustment and memory function.

Performance seats are available as an option on the XK and XKR. They provide a supreme combination of comfort and lateral support, with integrated head restraints and strongly sculpted side bolsters for exceptional support during hard cornering. They are upholstered in luxurious soft grain leather and feature 16-way electric positioning with heating and memory functions.







AIRBAG

# EMPOWER

Intuitive technology empowers but never overpowers the driving experience.

Press the pulsing red START button and the precision-made JaguarDrive Selector™ that controls the automatic transmission rises into the palm of the driver's hand. "Drive" is engaged with a simple twist. For maximum driver involvement gears can also be selected manually using paddle shifters mounted behind the steering wheel. The wheel itself features a host of interactive controls while the centre console 7 inch Touch-screen encapsulates Jaguar's design philosophy – simple and intuitive; you are never more than a few taps from any control. A masterpiece of clarity and smart functionality, it is used to operate the climate control, satellite navigation, Bluetooth® telephone system and in-car audio. The Front Media Interface provides control of an iPod or other MP3 player while USB storage devices can also be accessed. Other players can be connected to the car through a standard 3.5mm stereo auxiliary input port.

XK models can also be specified with a host of technologically innovative options that offer even greater convenience and driving pleasure. The Adaptive Front Lighting system features dynamic pivoting headlamps with integrated cornering lights that react to the car's speed and the driver's steering. It can deflect the headlight beams by up to 15 degrees, to cast light deeper into corners. Adaptive Cruise Control is designed to sense if the vehicle in front is moving at a slower speed and use the throttle and brakes to help maintain a constant time gap. The system automatically returns the car to its set speed once the road ahead has cleared. For assistance when parking, Jaguar's new Reverse Park Camera with Guidance provides a video display on the Touch-screen, along with a variable audio warning to alert the driver to the proximity of objects both in front of and behind the car.





# HYPERSONIC

The XK features the astonishing, precision crafted, Bowers & Wilkins surround sound system. Acoustically designed exclusively for the unique soundscape of the XK's cabin, it delivers 525W of pure sound through eight strategically positioned speakers utilising Kevlar® cones in the larger speakers and aluminium domes on the tweeters. It offers exceptionally clear reproduction using Dolby® Pro-Logic® II Surround Sound for extraordinary sound quality throughout the cabin.



THE MONOCOQUE BODYSHELL IS CONSTRUCTED FROM ALUMINIUM  
USING TECHNIQUES DERIVED FROM THE AEROSPACE INDUSTRY.  
THE RESULTING STRUCTURE COMBINES LIGHTNESS WITH STRENGTH  
AND EXCEPTIONAL RIGIDITY.

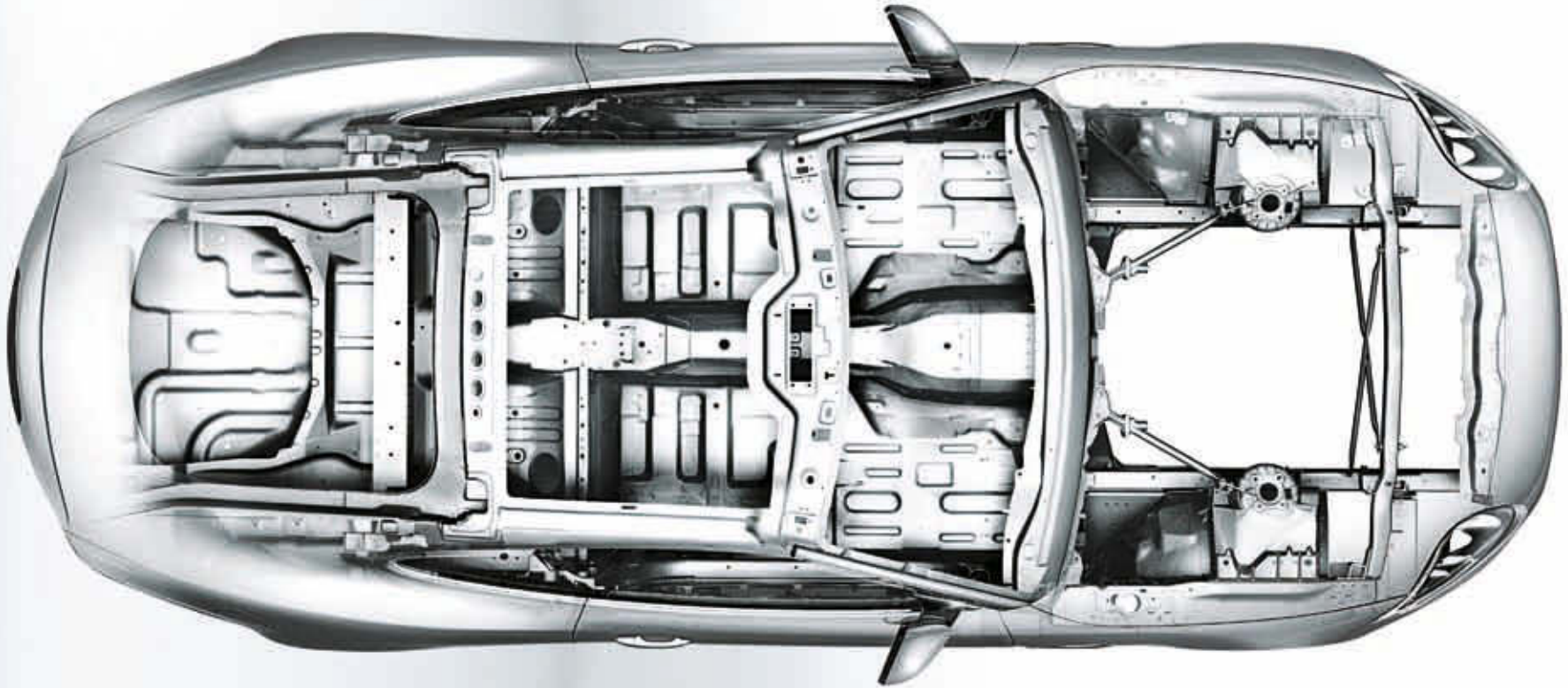

# SAFETY

## BY DESIGN

The XK's comprehensive range of advanced safety systems is designed to assist the driver in dealing with the unexpected, and help protect occupants and other road users.

Jaguar's unique and highly advanced Adaptive Restraint Technology System (ARTS™) helps to protect driver and passenger in the event of a collision. Within a fraction of a second, ARTS™ can assess the weight and position of the occupants, the severity of any impact, and deploy the XK's four dual-stage airbags.

The XK Convertible has its own array of safety features, including a highly advanced roll-over protection system. If the car's on-board sensors detect an impending roll-over, two massively strong hoops – hidden under the rear tonneau – are designed to deploy within 65 milliseconds. The XK even helps protect those around the car. The industry-leading Pedestrian Contact Sensing System™ is designed to raise the bonnet slightly if it detects a collision with a pedestrian in order to help prevent them from contacting hard points under the bonnet.









## R E S P O N S I B L E

In manufacturing the XK, Jaguar remains at the forefront of environmentally conscious production. Aluminium is not only completely recyclable but up to 50 percent of the XK's body structure is made from recycled aluminium.

In addition, many of the the XK's central components have been constructed out of recycled materials, such as the insulation, battery and filter housings, air distribution channels and engine compartment plastic constituents.





# XKR-S

The new XKR-S takes the Jaguar sports car experience to soaring new heights. Powered by a unique version of Jaguar's 5.0 Litre V8 Supercharged engine – calibrated to achieve 404kW and peak torque of 680Nm – the most powerful series production sports car Jaguar has ever produced is capable of 0-100 kph in just 4.4 seconds and a top speed of 300 kph.



## CONTROL

Bespoke changes to the Adaptive Dynamics, together with a 10mm reduction in ride height and extensive revisions to the suspension components and geometry deliver pin-sharp handling, maximise grip and optimise control. The unique 20" Vulcan lightweight forged alloy wheels feature increased tyre widths, while the performance active exhaust gives the XKR-S its own distinctive sound signature. Dramatic, bold exterior styling changes have been designed to improve aerodynamics, maintain stability and reduce lift at high speeds. They include a carbon fibre splitter and lower spoiler, extended sills and a unique rear wing apron and diffuser.







# UNIQUELY XKR-S

Inside a range of sporting themes are available, including exclusive carbon leather with Reims Blue micro-piping and stitching. A Poltrona Frau® Jet leather headlining and Dark Linear Aluminium veneer are standard. New 16-way adjustable Performance seats have strongly sculpted side bolsters for exceptional lateral support during hard cornering. A true driver's car – the experience is rewarding and unsurpassed for excitement.



# JAGUAR

XK 42    XKR 46    XKR-S 50    PERFORMANCE SEAT 54  
PERFORMANCE OPTIONS 56    ACCESSORIES 68







XK



## PERFORMANCE

### 5.0 V8 283KW PETROL COUPE

TORQUE Nm – 515

TOP SPEED kph – 250

0 - 100 kph SECONDS – 5.5

CARBON DIOXIDE EMISSIONS g/km – 264

URBAN l/100 km – 17.1

EXTRA URBAN l/100 km – 8.0

COMBINED l/100 km – 11.2

### 5.0 V8 283KW PETROL CONVERTIBLE

TORQUE Nm – 515

TOP SPEED kph – 250

0 - 100 kph SECONDS – 5.6

CARBON DIOXIDE EMISSIONS g/km – 264

URBAN l/100 km – 17.1

EXTRA URBAN l/100 km – 8.0

COMBINED l/100 km – 11.2

## MAIN FEATURES

Soft grain leather interior with twin needle contrast stitch

Luxury seats (16/16 way) with memory

19" Caravela alloy wheels

Bowers & Wilkins 525W surround sound system

Suedecloth premium headlining (excludes Convertible hood)

Jaguar Smart Key System™ with Keyless start and Keyless entry

Extended choice of veneer and interior combinations

Heated and cooled front seats

Heated leather steering wheel

Auto dimming exterior mirrors

6 disc in-facia CD

## SELECTED OPTIONS

Performance seats (16/16 way)

20" alloy wheels

Poltrona Frau® Jet leather headlining

Adaptive Front Lighting with dynamic pivoting headlamps and integrated cornering lights

Reverse park camera with guidance

Bright stainless steel pedals

Heated windscreen with timer

## WHEELS

Standard



19" Caravela

Options



19" Tamana



19" Artura



20" Selena



20" Kalimnos



20" Takoba



20" Orona



# XK

INTERIOR CHOICE

## HOOD COLOURS

No Cost Options

Options



Black

Blue

Beige

Dark Grey

Burgundy

Dark Green

Dark Brown

## VENEERS

Standard

No Cost Option

Options



Figured Ebony

Bright Knurled Aluminium

Burr Walnut

Satin Elm

Satin Rosewood

Rich Oak

Piano Black

## INTERIOR ENVIRONMENT

No Cost Options

Options

HEADLINING\*

UPPER FACIA

SEAT TRIM  
AND LEATHER



Warm Charcoal with Warm Charcoal upper facia and London Tan contrast stitch

Warm Charcoal with Warm Charcoal upper facia and Ivory contrast stitch†

Caramel with Warm Charcoal upper facia and Caramel contrast stitch

Caramel with Caramel upper facia and Warm Charcoal contrast stitch

Warm Charcoal and London Tan duo-tone with Warm Charcoal upper facia and London Tan contrast stitch†

Ivory with Warm Charcoal upper facia and Ivory contrast stitch†

Ivory with Oyster upper facia and Ivory contrast stitch

Ivory with Slate Blue upper facia and Ivory contrast stitch

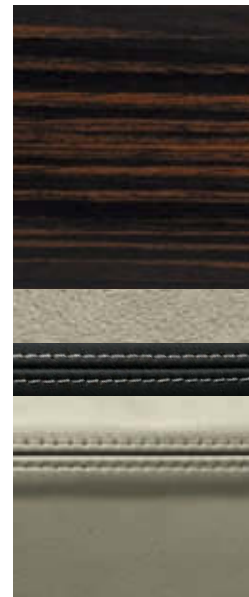

INTERIOR SHOWN  
Luxury seats in Ivory with Warm Charcoal upper facia, Ivory contrast stitch, Figured Ebony veneer and Canvas Suedecloth premium headlining

\*Canvas Suedecloth premium headlining as standard. Optional Jet Suedecloth and Poltona Frau® Jet leather headlining available as shown

†Available on optional Performance seats see page 54

XKR



## PERFORMANCE

### 5.0 V8 SUPERCHARGED 375KW PETROL COUPE

TORQUE Nm – 625

TOP SPEED kph – 250

0 - 100 kph SECONDS – 4.8

CARBON DIOXIDE EMISSIONS g/km – 292

URBAN l/100 km – 18.9

EXTRA URBAN l/100 km – 8.6

COMBINED l/100 km – 12.3

### 5.0 V8 SUPERCHARGED 375KW PETROL CONVERTIBLE

TORQUE Nm – 625

TOP SPEED kph – 250

0 - 100 kph SECONDS – 4.8

CARBON DIOXIDE EMISSIONS g/km – 292

URBAN l/100 km – 18.9

EXTRA URBAN l/100 km – 8.6

COMBINED l/100 km – 12.3

## MAIN FEATURES

IN ADDITION TO XK

Active Differential

19" Tamana alloy wheels

Bonnet louvres with Supercharged script

Jaguar High Performance Braking System with gunmetal calipers

Sports Active Exhaust with quad tailpipes

## SELECTED OPTIONS

Performance seats (16/16 way)

Reverse park camera with guidance

Poltrona Frau® Jet leather headlining

Adaptive Front Lighting with dynamic pivoting headlamps and integrated cornering lights

Bright stainless steel pedals

Adaptive Cruise Control (ACC) with Forward Alert

Heated windscreen with timer

XKR Aerodynamic Pack

## WHEELS

Standard



19" Tamana

Options



20" Kalimnos



20" Takoba



20" Nevis



20" Orona



IR



R





# XKR

## INTERIOR CHOICE

### HOOD COLOURS

No Cost Options

Options



Black

Blue

Beige

Dark Grey

Burgundy

Dark Green

Dark Brown

### VENEERS

Standard

No Cost Option

Options



Dark Mesh Aluminium

Dark Oak

Burr Walnut

Satin Elm

Satin Rosewood

Rich Oak

Piano Black

### INTERIOR ENVIRONMENT

Standard

Options

HEADLINING\*

UPPER FACIA

SEAT TRIM  
AND LEATHER



Warm Charcoal with Warm Charcoal upper facia†

Warm Charcoal with Warm Charcoal upper facia and Ivory contrast stitch†

Warm Charcoal with Warm Charcoal upper facia and London Tan contrast stitch

Warm Charcoal with Warm Charcoal upper facia and Red contrast stitch†

Ivory with Warm Charcoal upper facia and Ivory contrast stitch†

Warm Charcoal and London Tan duo-tone with Warm Charcoal upper facia and London Tan contrast stitch†

Warm Charcoal and Red duo-tone with Warm Charcoal upper facia and Red contrast stitch†

INTERIOR SHOWN  
Luxury seats in Warm Charcoal with Warm Charcoal upper facia, Red contrast stitch, Dark Mesh Aluminium veneer and Jet Suedecloth premium headlining

\*Jet Suedecloth premium headlining as standard. Optional Canvas Suedecloth and Poltona Frau® Jet leather headlining available as shown  
†Available on optional Performance seats see page 54

XKR-S



## PERFORMANCE

### 5.0 V8 SUPERCHARGED 404KW PETROL COUPE

TORQUE Nm – 680

TOP SPEED kph – 300

0 - 100 kph SECONDS – 4.4

CARBON DIOXIDE EMISSIONS g/km – 292

URBAN l/100 km – 18.9

EXTRA URBAN l/100 km – 8.6

COMBINED l/100 km – 12.3

## MAIN FEATURES

### IN ADDITION TO XKR

Jaguar High Performance Braking System with red calipers

20" Vulcan alloy wheels, forged and lightweight, dark technical finish

Revised springs, revised dampers and forged and fully machined front knuckle

Uprated Active Differential

Uprated Adaptive Dynamics

10mm ride height reduction

Performance Active Exhaust with quad tailpipes

Unique front bumper with twin nacelles, broad vertical side intakes and carbon fibre splitter

Extended side sills

Rear apron featuring carbon fibre diffuser

Unique rear wing with carbon fibre inlay

Performance seats with carbon and soft grain leather (16/16 way)

Bright stainless steel pedals

XKR-S tread plates

Poltrona Frau® Jet leather headlining

Unique Dark Linear Aluminium veneer

Reverse park camera with guidance

## SELECTED OPTIONS

20" Vulcan alloy wheels with Gloss Black Finish

Carbon fibre engine cover

Sport Steering wheel trimmed in Jet Suedecloth

Adaptive Front Lighting with dynamic pivoting headlamps and integrated cornering lights

Tyre Pressure Monitoring System (TPMS)

Gunmetal brake calipers

## WHEELS

Standard



20" Vulcan Dark  
Technical Finish

Option



20" Vulcan Gloss  
Black Finish



# XKR - S

## INTERIOR CHOICE

### VENEERS

Standard

No Cost Option

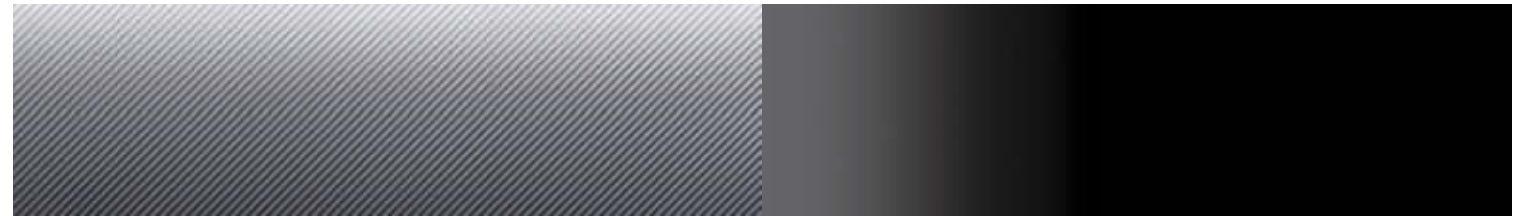

Dark Linear Aluminium

Piano Black

### INTERIOR ENVIRONMENT

No Cost Options

HEADLINING\*

UPPER FACIA

SEAT TRIM  
AND LEATHER

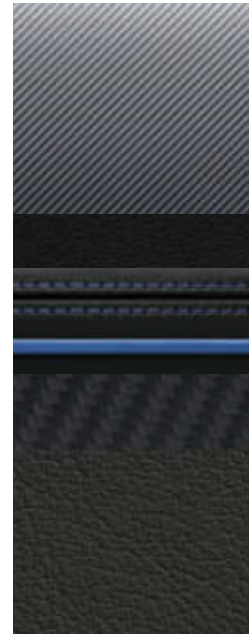
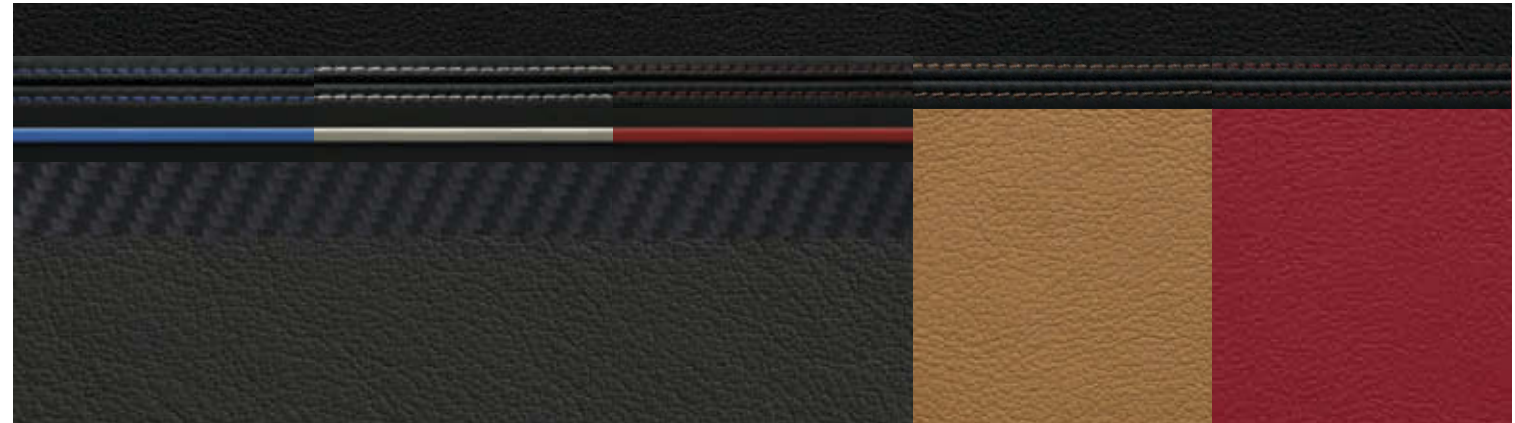

INTERIOR SHOWN  
Performance seats in Warm Charcoal and carbon with Warm Charcoal upper facia and Reims Blue contrast micro-piping and stitch, Dark Linear Aluminium veneer and Poltrona Frau® Jet leather headlining

Performance seats in Warm Charcoal and carbon with Warm Charcoal upper facia and Reims Blue contrast micro-piping and stitch

Performance seats in Warm Charcoal and carbon with Warm Charcoal upper facia and Ivory contrast micro-piping and stitch

Performance seats in Warm Charcoal and carbon with Warm Charcoal upper facia and Red contrast micro-piping and stitch

Performance seats in Warm Charcoal and London Tan duo-tone with Warm Charcoal upper facia and London Tan contrast stitch

Performance seats in Warm Charcoal and Red duo-tone with Warm Charcoal upper facia and Red contrast stitch

\*Poltrona Frau® Jet leather headlining



## PERFORMANCE SEAT

The new Performance seat is standard on the XKR-S and available as an option on the XKR and XK (without XKR-S logo). Designed to provide the optimum combination of lateral support and superb comfort, Performance seats feature integrated head restraints and strongly sculpted side bolsters for exceptional support during hard cornering. They are 16-way electrically adjustable and include heat and memory functionality.

### INTERIOR ENVIRONMENT

XK and XKR



Performance seats in Warm Charcoal with Warm Charcoal upper facia and Ivory contrast stitch

Performance seats in Warm Charcoal and London Tan duo-tone with Warm Charcoal upper facia and London Tan contrast stitch

Performance seats in Ivory with Warm Charcoal upper facia and Ivory contrast stitch

XKR only



Performance seats in Warm Charcoal with Warm Charcoal upper facia

Performance seats in Warm Charcoal with Warm Charcoal upper facia and Red contrast stitch

Performance seats in Warm Charcoal and Red duo-tone with Warm Charcoal upper facia and Red contrast stitch

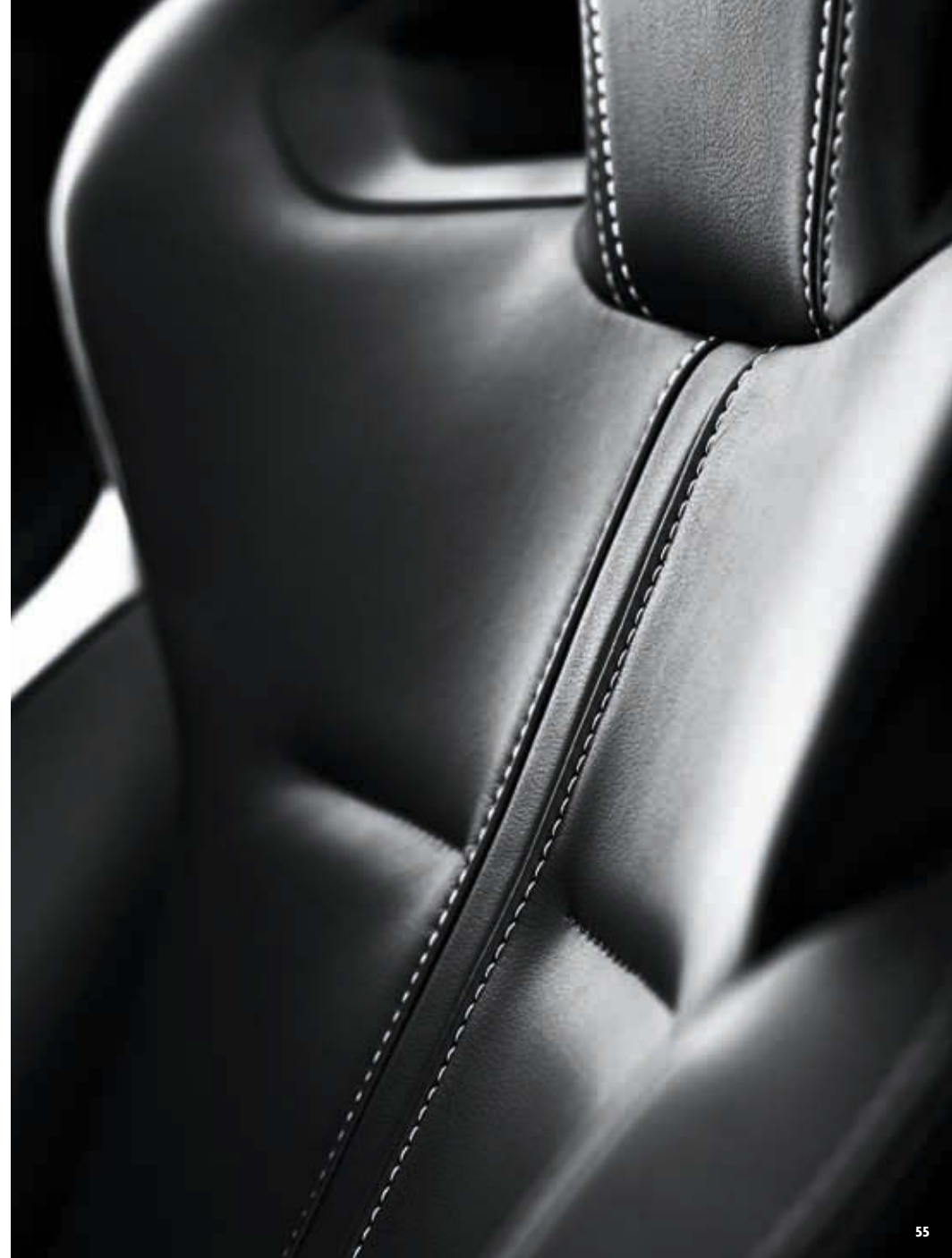

## PERFORMANCE AND TECHNICAL OPTIONS



### ADAPTIVE FRONT LIGHTING WITH DYNAMIC PIVOTING HEADLAMPS AND INTEGRATED CORNERING LIGHTS

This optional system features dynamic pivoting headlights that react to the car's speed as well as the driver's steering and can deflect the headlight beams by up to 15 degrees, casting light deeper into corners to improve visibility while cornering. Cornering lights illuminate areas to the side of the car at low speeds when the indicators are in use, or at larger steering angles, for example when parking.

(Optional on all XK models)



### REVERSE PARK CAMERA WITH GUIDANCE

This new optional feature provides added convenience and safety when reversing. Discreetly located in the rear boot lid finisher and operated via the Touch-screen, it integrates with the standard front and rear parking aids.

(Standard on XKR-S, optional on all other XK models)





**BRIGHT STAINLESS STEEL PEDALS**  
Made from stainless steel and rubber, the pedals fit securely over existing pedals for a contemporary, sporting appearance.  
(Standard on XKR-S, optional on all other XK models)



**POLTRONA FRAU®**  
**JET LEATHER HEADLINING**  
Produced by renowned furnishings house Poltrona Frau®, which draws upon its extensive experience in creating premium interiors for the motor industry.  
(Standard on XKR-S, optional on all other XK models)



XKR-S

XKR-S

# UNIQUE XKR-S OPTIONS

## XKR-S DECALS

To add even greater distinction and individuality and to leave no doubt that this is the XKR-S, unique decals are available as a dealer fit accessory. These two-part decals sit one on top of the front wing and over the opposite rear haunch of the car\*.

## CARBON FIBRE ENGINE COVER

The optional Carbon Fibre engine cover with R-S logos is guaranteed to grab attention the moment the bonnet is lifted.

\*Please consult your Jaguar dealer for final confirmation of decal design.





## EXTERIOR COLOURS

### STANDARD

Ebony

Polaris White  
RS

Jaguar's new colour palette has been developed to reflect the vitality and elegance of the vehicle. The Standard colours express a unique style and subtle sophistication. Jaguar also offers a further range of Premium finishes, as well as the exclusive Special selection colours. Racing Inspired finishes evoke Jaguar's formidable sporting heritage.

RS XKR-S Colours

\*Metallic paint  
†Xirallic paint

For availability please consult your local Jaguar dealer.

### PREMIUM

Ultimate Black†  
RS

Stratus Grey†  
RS

Lunar Grey\*

Rhodium Silver\*

Cashmere\*  
Not available on XKR

Crystal Blue\*



SPECIAL

Indigo†

Caviar†  
Not available on XKR

Claret\*



Black Amethyst†

Kyanite Blue†



RACE INSPIRED

British Racing Green†  
RS

Italian Racing Red†  
RS

French Racing Blue  
RS (XKR-S ONLY)



# STANDARD FEATURES

ALL MODELS

## POWERTRAIN AND DRIVING DYNAMICS

6-speed electronic automatic transmission with Jaguar Sequential Shift™  
JaguarDrive Selector™  
JaguarDrive Control™ with Winter Mode and Dynamic Mode  
Adaptive Dynamics  
Cruise Control with Automatic Speed Limiter (ASL)  
Electronic Brake-force Distribution (EBD)  
Electric Parking Brake (EPB) – drive-away release  
Dynamic Stability Control (with Trac DSC mode)

## EXTERIOR FEATURES

Bi-function HID Xenon headlamps with LED daytime running lights and automatic levelling  
LED tail lamps  
Automatic headlamps  
Automatic headlamp washers  
Rain sensing windscreen wipers  
Heated exterior mirrors with electric adjustment, power-folding with auto-powerfold on locking vehicle and memory function with integrated LED side repeaters and approach lamps  
Front and rear parking aid with Touch-screen visual indicator  
Rear spoiler  
Electronically operated Convertible hood with integrated tonneau cover (Convertible only)

## INTERIOR FEATURES

Dual zone automatic climate control  
Auto-dimming interior rear view mirror  
Auxiliary power socket (centre console)  
Twin cup holders  
Front electric windows with one touch open/close and anti-trap  
Trip computer with message centre  
Jaguar Smart Key System™ with Keyless start and Keyless entry  
Front ashtray and lighter  
Phosphor blue halo illumination and interior mood lighting  
Clock in Touch-screen  
Memory function for driver's and passenger seat, exterior mirrors and steering column

## SAFETY AND SECURITY

Remote control central locking with dead locking and drive-away locking  
Engine immobiliser  
Valet mode  
Anti-lock Braking System (ABS)  
Emergency Brake Assist (EBA)  
Roll-over Protection System (Convertible only)  
Airbags front and side (driver and front passenger)  
Adaptive Restraint Technology System (ARTS™)  
Front and rear seat belt pre-tensioners  
Front seat whiplash reduction system  
Belt minder system (front seats only)  
Pedestrian Contact Sensing System™ – Automatically deployable bonnet system

## MULTIMEDIA

Front Media Interface with AUX socket, USB and iPod connectivity  
Windows Media Audio (WMA) and MP3 compatibility  
Bluetooth® telephone connectivity  
Navigation system with DVD mapping  
7 inch colour Touch-screen display



# OPTIONAL FEATURES

	XK	XKR	XKR-S		XK	XKR	XKR-S
<b>POWERTRAIN AND DRIVING DYNAMICS</b>				<b>SAFETY AND SECURITY</b>			
Adaptive Cruise Control (ACC) with Forward Alert	○	○	-	Tyre Pressure Monitoring System (TPMS)*	○	○	○
Gunmetal brake calipers	-	●	NCO	<b>WHEELS</b>			
Red brake calipers	-	○	●	Optional Wheels	See pages 66/67		
Carbon fibre engine cover	-	-	○	18" alloy space saver spare wheel	●	-	-
<b>PAINT</b>				19" alloy space saver spare wheel	-	●	-
Special paint	○	○	NCO	<b>INTERIOR TRIM</b>			
Race Inspired paint	○	○	NCO	Performance seats in soft grain leather (16/16 way)	○	○	●
<b>VENEERS</b>				Suedecloth premium headlining	●	●	-
Bright Knurled Aluminium	NCO	-	-	Poltrona Frau® Jet leather headlining	○	○	●
Veneer Change (various, see trim pages for applicability)	○	○	-	Ivory leather	○	○	-
Piano Black	○	○	NCO	<b>PACKS</b>			
<b>EXTERIOR FEATURES</b>				XKR Aerodynamic Pack	-	○	-
Heated windscreen with timer	○	○	○				
Adaptive Front Lighting with dynamic pivoting headlamps and integrated cornering lights	○	○	○				
Premium Convertible hood colours	○	○	-				
Reverse park camera with guidance	○	○	●				

○ Option ● Standard NCO No Cost Option - Not available

\*Tyre Pressure Monitoring system (TPMS) is not available with 18" alloy wheels



# TECHNICAL SPECIFICATIONS

ENGINES		5.0 V8 283KW PETROL COUPE AJ-V8 GEN III	5.0 V8 283KW PETROL CONVERTIBLE AJ-V8 GEN III	5.0 V8 SUPERCHARGED 375KW PETROL COUPE AJ-V8 GEN III R	5.0 V8 SUPERCHARGED 375KW PETROL CONVERTIBLE AJ-V8 GEN III R	5.0 V8 SUPERCHARGED 404KW PETROL COUPE AJ-V8 GEN III R
Cylinders/Valves per Cylinder		8/4	8/4	8/4	8/4	8/4
Bore/Stroke	mm	92.5/93	92.5/93	92.5/93	92.5/93	92.5/93
Capacity	cc	5,000	5,000	5,000	5,000	5,000
Maximum power	kW	283	283	375	375	404
@rev/min		6,500	6,500	6,000-6,500	6,000-6,500	6,000-6,500
Maximum torque	Nm	515	515	625	625	680
@rev/min		3,500	3,500	2,500-5,500	2,500-5,500	2,500-5,500
Compression	ratio:1	11.5	11.5	9.5	9.5	9.5
Transmission		6-speed automatic	6-speed automatic	6-speed automatic	6-speed automatic	6-speed automatic
PERFORMANCE						
0-100 kph	seconds	5.5	5.6	4.8	4.8	4.4
Top speed	kph	250 limited	250 limited	250 limited	250 limited	300 limited
FUEL CONSUMPTION <sup>(1)</sup>						
Urban	l/100km	17.1	17.1	18.9	18.9	18.9
Extra Urban	l/100km	8.0	8.0	8.6	8.6	8.6
Combined	l/100km	11.2	11.2	12.3	12.3	12.3
Carbon dioxide emissions	g/km	264	264	292	292	292
Tank capacity	ltr approx.	70.6	70.6	70.6	70.6	70.6
WEIGHT <sup>(2)</sup> /DIMENSIONS						
Weight	kg	1,660	1,696	1,753	1,800	1,753
Gross vehicle weight	kg	2,075	2,120	2,145	2,185	2,145
Turning circle diameter	m	10.9	10.9	10.9	10.9	10.9
Boot volume with roof up	litres - VDA	330	313	330	313	330
Boot volume with roof down	litres - VDA	N/A	200	N/A	200	N/A

<sup>(1)</sup>All fuel economy data has been measured in accordance with current Australian ADR 81/02 test procedures. Under normal use a vehicle's actual fuel consumption may differ from that achieved through the test procedure, depending on driving technique, road and traffic conditions, environmental factors and vehicle condition. If in doubt, please consult your dealer; the information given is correct at time of publication.

<sup>(2)</sup>Please consult your local Jaguar dealer for details of charges associated with option fitment. Weights reflect vehicles to standard specifications. Optional extras increase weight.

NOTE: The dimension details refer to a nominal car but may vary marginally from car to car due to design and production tolerances. The nominal condition has been used wherever possible. Please consult your local Jaguar dealer for details of changes associated with option fitment.

# WHEEL OPTIONS



19" Caravela



19" Artura



19" Tamana



20" Nevis

## X K

5.0 V8 283kW Petrol Coupé



5.0 V8 283kW Petrol Convertible



## X K R

5.0 V8 Supercharged 375kW Petrol Coupé



5.0 V8 Supercharged 375kW Petrol Convertible



## X K R - S

5.0 V8 Supercharged 404kW Petrol Coupé



○ Option ● Standard - Not Available

\*Available late 2011



20" Kalimnos



20" Orona



20" Selena



20" Takoba



20" Vulcan  
Dark Technical Finish



20" Vulcan  
Gloss Black Finish

o  
o

o  
o

o  
o

o  
o

-  
-

-  
-

o  
o

o  
o

-  
-

o  
o

-  
-

-  
-

-

-

-

-

●

o

# ACCESSORIES

## EXTERIOR STYLING



### BLACK AND CHROME GRILLE SETS

Replacement upper & lower front grilles available in 2 distinct finishes with matching or contrast upper grille surrounds. Available on all XK models excepts XKR-S.

Chrome grilles - C2P18324 & C2P18024

Black grilles - C2P18325 & C2P18025

Upper grille surround - chrome - C2Z17648

Upper grille surround - black - C2P21934



### XKR AERODYNAMIC PACK

The Aerodynamic Pack is available exclusively for XKR models and consists of a front splitter and larger rear spoiler.

Aero kit rear spoiler - C2P22061XXX

Front splitter - C2P22272XXX, C2P22274XXX & C2P22276XXX



### XKR DECAL

Vehicle decal designed to enhance the sporty lines and appearance of the XKR Coupé and Convertible.

C2P22312 & C2P22313



#### 20" GLOSS BLACK TAKOBA ALLOY WHEELS

Front - C2P21003

Rear - C2P21004



#### STYLED VALVE CAPS

Complete the look of your XK's wheels with custom valve caps.

Available featuring 4 iconic designs.

Valve caps with Black Jack - C2D19598

Valve caps with Union Jack - C2D19599

Valve caps with Jaguar logo - C2D19596

Valve caps with 'R' logo - C2D19597



#### CENTRE WHEEL BADGE - WHEEL NUTS

A distinctive red wheel centre badge featuring the Jaguar logo that fits all available wheels. Enhance the look of your XK's wheels with Jaguar branded black or chrome wheel nuts.

Wheel centre badge - red - C2D12326

Wheel nut kit - chrome with Jaguar logo - C2D20072

Wheel nut kit - black with Jaguar logo - C2D20073

#### ALLOY WHEELS

The following wheels are also available as accessories. See alloy wheel options page 66-67.

##### 19" CARAVELA

Front - C2P12613

Rear - C2P12614

##### 19" ARTURA

Front - C2P14209

Rear - C2P12617

##### 19" TAMANA

Front - C2P12619

Rear - C2P12620

##### 20" KALIMNOS

Front - C2P12615

Rear - C2P12616

##### 20" NEVIS

Front - C2Z4429

Rear - C2P15688

# ACCESSORIES

## EXTERIOR STYLING



### CHROME DOOR MIRRORS

Chrome mirror covers accentuate the stylish design of the XK's exterior mirrors and add further individuality to the car's unique lines and sporting character.  
C2D5489 & C2D5488



### BONNET LOUVRES WITH CHROME STRAKES

Stunning body coloured louvres with black mesh and styled chrome inserts add further emphasis to one of the XKRs most distinctive styling features.  
Available on XKR and XKR-S only.  
C2P20035XXX



### POLISHED EXHAUST TAILPIPE FINISHERS (PAIR)

Stainless steel exhaust finishers add further style, sportiness and refinement to the XK.  
Not available for XKR.  
C2P18000

## INTERIOR STYLING



### WIND DEFLECTOR

Add comfort during open top driving and reduce driver and passenger wind buffeting with the pop-up, removable wind deflector in brushed aluminium finish. Also available in black finish.

Bright finish - C2P17566

Black finish - C2P2440



### LEATHER TOPPED GEAR SELECTOR

A specially designed gear selector with premium dark leather finished top and rubber bezel with soft touch grip.

C2D21919PVJ & C2D21956

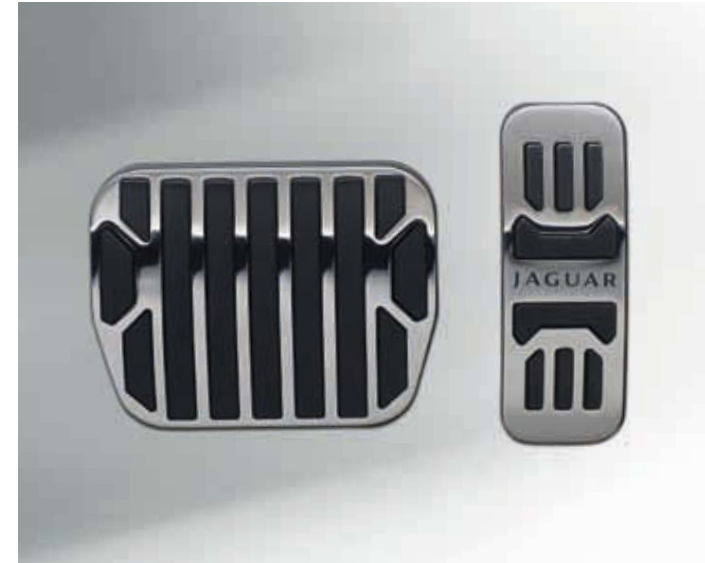

### SPORT PEDAL COVERS

Made from stainless steel and rubber, the pedal kit fits securely over existing pedals for a contemporary, sporting appearance.

C2P23554

# ACCESSORIES

## INTERIOR UTILITY



### LUGGAGE COMPARTMENT PREMIUM CARPET MAT

Luxurious soft luggage mat in Jet black with the Jaguar logo. Deep premium 2050g/m<sup>2</sup> pile with nubuck edging and dove contrast stitch.

Coupé - C2P22021

Convertible - C2P22022



### LUGGAGE SPACE EXTENSION KIT CARPET INSERT

This kit replaces the spare wheel in the XK luggage compartment with a trimmed liner to offer additional space. Includes an emergency tyre puncture repair system.

C2P20314, C2P17107, C2Z10213, C2P20105 & C2P17247

### LUGGAGE COMPARTMENT FINISHER

This Jaguar branded finisher enhances the XK boot area. The finisher is made from stainless steel, has a brushed finish with bright highlights and adds aesthetic appeal as well as scuff protection.

C2P20762





PREMIUM CARPET MAT SET

Luxurious, tailored 780g/m<sup>2</sup> pile front carpet mat set with embossed Jaguar logo and nubuck edge binding. The premium mats provide a well appointed finishing touch to the interior. Available in the following colours:

Flint with Warm Charcoal edge  
C2P21740YKM

Caramel with Caramel edge  
C2P21740YHQ

Flint with Ivory edge (not shown)  
C2P21740YLD



LUGGAGE COMPARTMENT LINER

Fitted semi-rigid rubber liner to protect the floor of the luggage compartment.  
C2P2457

ALL-WEATHER CAR COVER  
All-weather tailored cover for the XK with the Jaguar logo. Protect your XK from the elements, including showers, frost and dust. Quick and easy to fit.  
C2P21323

BULB KIT  
C2P8534

WARNING TRIANGLE  
C2S20992

LOCKING WHEEL NUTS  
C2C9198

# GLOSSARY

## POWERTRAIN AND DRIVING DYNAMICS

### JAGUAR SEQUENTIAL SHIFT™

Provides the choice of Drive, Sport Automatic or Manual gearshift modes, with one touch paddles mounted behind the steering wheel to control gear changes manually.

### ADAPTIVE DYNAMICS

Designed to provide the optimum balance between low speed ride comfort and high speed handling precision, analysing body movement, steering and road wheel inputs up to 500 times a second and continuously adjusting the suspension settings through electronically controlled dampers.

### ACTIVE DIFFERENTIAL

An electronically controlled, active differential with Handling Functionality that limits the slip between the rear wheels to improve traction and stability in different driving conditions, working in harmony with the Traction, ABS and DSC systems.

### DYNAMIC STABILITY CONTROL (WITH TRAC DSC MODE)

Intervenes in demanding driving situations by applying braking to individual wheels and reducing engine torque.

### JAGUAR DRIVE CONTROL™

Interacts with the DSC (Dynamic Stability Control) engine and transmission management systems to change the characteristics of engine mapping, transmission shifts and brake interventions. It offers different modes selectable by a button and is designed to optimise the vehicle response depending on driving conditions and style.

### WINTER MODE

Softens the responsiveness of the engine and modifies the gear change strategy to improve traction in icy or slippery conditions. The vehicle performs in a more gentle and controlled manner, allowing more confident progress. When active, Winter Mode selects 2nd gear for pulling away on level ground (no incline).

### DYNAMIC MODE

Designed to optimise vehicle systems to deliver a more involving driving experience. When Dynamic Mode is selected, Trac DSC is automatically engaged, and engine torque delivery characteristics and gear shift points are modified to further improve responsiveness. When selected while the transmission is in full Manual mode, transmission up-shifts are fully controlled by the driver, with no automatic up-shift when the rev limit is reached.

## EXTERIOR FEATURES

### ADAPTIVE FRONT LIGHTING WITH DYNAMIC PIVOTING HEADLAMPS AND INTEGRATED CORNERING LIGHTS

Sensors react to the car's speed and steering input, and the system can deflect the headlight beams by up to 15 degrees casting light deeper into corners, and giving added confidence at night.

### XKR AERODYNAMIC PACK

Body coloured front splitter and body coloured larger rear spoiler.

## INTERIOR FEATURES

### AIR QUALITY SENSOR

Automatic cabin recirculation triggered by external odour sensor with 5 sensitivity settings.

### JAGUAR SMART KEY SYSTEM™ WITH KEYLESS ENTRY

With the Jaguar Smart Key in your pocket or bag, the car automatically unlocks as you pull the door handle. Simply push the ignition button to start the engine. Upon leaving, simply press a button on the door handle to lock the car or use the Jaguar Smart Key.

### VALET MODE

When Valet mode is enabled, the vehicle can be parked by a parking attendant who can lock the vehicle, but cannot open the luggage or glove compartments. Valet mode can be enabled and disabled through a secure function in the Touch-screen.

## SAFETY AND SECURITY

### ROLL-OVER PROTECTION SYSTEM

Two automatically deployable hoops which are designed to activate in a roll-over event (Convertible only).

## MULTIMEDIA

### NAVIGATION SYSTEM<sup>(1)(2)</sup>

7 inch Touch-screen display with DVD mapping.

### BOWERS & WILKINS 525W SURROUND SOUND SYSTEM

Featuring a unique multichannel amplifier with Dolby® Pro Logic® II Surround Sound, 3 channel Stereo, and specially-designed Bowers & Wilkins loudspeaker components, including high-output, low-distortion Kevlar® speakers and extended high-frequency aluminium dome tweeters.

### WINDOWS MEDIA AUDIO (WMA) AND MP3 COMPATIBILITY

Enables the CD player to play CDs which contain WMA and MP3 files.

## INTERIOR THEMES

### XK INTERIOR THEME\*

Luxury seats in soft grain leather with contrast stitch, 16/16 way driver's and passenger's electric adjustment, variable manual headrest, includes 4-way power lumbar, driver and passenger memory, front cushion length adjust, variable bolster and perforated (front and rear). Variable heated and cooled. Soft grain contrast stitch leather to steering wheel, doors, rear side panels, instrument panel and centre console with twin stitch detail. (No contrast stitch to Ivory seats). Canvas Suedecloth premium headlining. Nubuck edged premium carpet mat set with Jaguar script and logo. Heated leather steering wheel. Bowers & Wilkins 525W surround sound system.

### XKR INTERIOR THEME\*

Luxury seats in soft grain leather with contrast stitch, 16/16 way driver's and passenger's electric adjustment, variable manual headrest with R logo, includes 4-way power lumbar, driver and passenger memory, front cushion length adjust, variable bolster and perforated (front and rear). Variable heated and cooled. Soft grain contrast stitch leather to steering wheel, doors, rear side panels, instrument panel and centre console with twin stitch detail. (No contrast stitch to Ivory seats). Jet Suedecloth premium headlining. Nubuck edged premium carpet mat set with Jaguar script and logo. Heated leather steering wheel. Bowers & Wilkins 525W surround sound system.

### XKR-S INTERIOR THEME\*

Performance seats in carbon and soft grain leather with contrast micro-piping and stitch, 16/16 way driver's and passenger's electric adjustment, variable manual headrest with R-S logo, includes 4-way power lumbar, driver and passenger memory, front cushion length adjust, variable bolster. Variable heated. Carbon and soft grain leather to door inserts and rear side panels. Soft grain contrast stitch leather to steering wheel, doors, rear side panels, instrument panel and centre console with twin stitch detail. Poltrona Frau® Jet leather headlining. Nubuck edged premium carpet mat set with Jaguar script and logo. Heated leather steering wheel. Bowers & Wilkins 525W surround sound system.

## WHEEL SPECIFICATIONS

	FRONT	TYRES	REAR	TYRES
Caravela alloy wheels	8.5J x 19"	245/40 R19	9.5J x 19"	275/35 R19
Artura alloy wheels	8.5J x 19"	245/40 R19	9.5J x 19"	275/35 R19
Tamana alloy wheels	8.5J x 19"	245/40 R19	9.5J x 19"	275/35 R19
Kalimnos alloy wheels	8.5J x 20"	255/35 R20	9.5J x 20"	285/30 R20
Nevis alloy wheels	8.5J x 20"	255/35 R20	9.5J x 20"	285/30 R20
Selena alloy wheels	8.5J x 20"	255/35 R20	9.5J x 20"	285/30 R20
Takoba alloy wheels	8.5J x 20"	255/35 R20	9.5J x 20"	285/30 R20
Orona alloy wheels	9.0J x 20"	255/35 R20	10.0J x 20"	285/30 R20
Vulcan alloy wheels	9.0J x 20"	255/35 R20	10.5J x 20"	295/30 R20

\*Non-leather used on some surfaces

<sup>(1)</sup>Different DVDs exist in different regions. Please consult your local Jaguar dealer for details of which countries are covered by the DVD supplied with your vehicle.

<sup>(2)</sup>The navigation system must always be used in conditions that will not affect the driver's ability to drive safely or affect the safety of other road users.

# XK OWNERSHIP EXPERIENCE

SERVICE, ASSURANCE, AND PEACE OF MIND ARE ALL PART OF THE PRIDE OF OWNING YOUR XK.

## THE JAGUAR ACCESSORY RANGE

Enabling you to personalise your car, to create a driving experience that is even more individually rewarding. All Jaguar accessories are tested rigorously for safety and durability in the most arduous of climates and conditions.

A comprehensive range of styling options, interior and exterior accessories, enabling you to tailor your XK to suit your personal style.

## BECAUSE ONLY THE BEST WILL DO

An official Jaguar dealer can ensure that Jaguar trained, specialist technicians, with access to the full range of Jaguar approved parts and tools, will always be on hand to guarantee that every fitting, or repair, is carried out exactly the way Jaguar intended. Your Jaguar dealer can also supply and fit Jaguar approved accessories to personalise and add to the practicality and style of your XK model.

## JAGUAR ROADSIDE ASSISTANCE†

All Jaguar vehicles purchased in Australia benefit from complimentary Jaguar Roadside Assistance service for the length of the new car warranty. This covers you Australia-wide 24 hours per day, every day.

## WARRANTY\*†

3 year/100,000km\* Mechanical Warranty together with a 3 year unlimited kilometre Paint Surface Warranty and 6 year unlimited kilometre Corrosion (Perforation) Warranty.

## JAGUAR MAGAZINE

Bringing to life Jaguar's racing heart, Jaguar Magazine is our owner publication. It combines features on our legendary performance, the inside track on our products and company, along with news and events from the world of Jaguar.

## JAGUAR.COM.AU

Dedicated to you and your XK, the interactive jaguar.com.au website features helpful tools such as the dealer locator, model specifications - allowing you to see the car tailored to your specification and colour; the latest information on all the Jaguar models and a fascinating look into the passion and legacy that infuse the Jaguar name.

## FREE SCHEDULED SERVICE

3 year / 100,000 kilometre\* free scheduled service programme (wear and tear items not included).\*\*

## NOTICE – CHANGE TO WARRANTY

All new 2012 model year Jaguars now come with a 3 year unlimited kilometre Mechanical Warranty together with a 3 year unlimited kilometre Paint Surface Warranty and 6 year unlimited kilometre Corrosion (Perforation) Warranty.

\*Whichever is the earliest.

\*\*Wear and tear items include battery, tyres, oils and additives.

†Terms and Conditions apply. Please contact your Jaguar dealer for more information.





JAGUAR



BY APPOINTMENT TO  
HER MAJESTY ELIZABETH II  
MANUFACTURER OF  
CARS AND JAGUAR CARS  
JAGUAR CARS LIMITED COVENTRY



BY APPOINTMENT TO HER MAJESTY  
HER MAJESTY THE QUEEN MOTHER  
MANUFACTURER OF  
CARS AND JAGUAR CARS  
JAGUAR CARS LIMITED COVENTRY

PREVIOUS APPOINTMENT TO THE LATE QUEEN ELIZABETH THE QUEEN MOTHER 1984-2001

#### IMPORTANT NOTICE

Jaguar Cars Limited is constantly seeking ways to improve the specification, design and production of its vehicles and alterations take place continually. Whilst every effort is made to produce up-to-date literature, this brochure should not be regarded as an infallible guide to current specifications. Jaguar Australia reserves the right to alter these specifications at any time. This brochure does not constitute an offer for the sale of any particular vehicle. Distributors and dealers are not agents of Jaguar Cars limited and have absolutely no authority to bind Jaguar Cars Limited by any express or implied undertaking or representation, illustrations in this brochure may include optional extras.

Comparisons are based on manufacturer's own data and testing.

#### ENVIRONMENTAL NOTICE

Jaguar cars Limited has a vision of being amongst the world's leading companies in demonstrating progress towards sustainability. We aim to do this by contributing to a better quality of life, with corporate citizenship at the very heart of our company. Environmental responsibility is a core value in Jaguar, and it is our policy to continually improve our environmental standards in all areas of business activity.

The Bluetooth® word mark and logos are owned by the Bluetooth SIG, Inc. and any use of such marks by Jaguar Cars Limited is under license.

iPod, iPod touch and iPad are trademarks of Apple Inc., registered in the U.S. and other countries.

BlackBerry® is a trademark of Research In Motion Limited and is registered in the U.S. and may be pending or registered in other countries.

Dolby and Pro Logic are registered trademarks of Dolby Laboratories.

DTS™ is a registered trademark of DTS Inc. and any use of such marks by Jaguar Cars Limited is under license.

Audyssey MultEQ® is a registered trademark of Audyssey Laboratories, Inc. and any use of such marks by Jaguar Cars Limited is under license.

WhiteFire® is a registered trademark of Unwired Technology LLC and any use of such marks by Jaguar Cars Limited is under license.

Bowers & Wilkins is a registered trademark of B&W Group Limited.

Jaguar Australia Locked Bag 2213  
North Ryde NSW 1670  
Phone: 1800 450 683 or 02 9020 1400  
Fax: 02 9020 1794  
Jaguar.com.au

JLM/37/02/03/0911



JAGUAR.COM.AU