



GROUP
Engine

MODEL
Optima (MS)
Sportage (KM)

NUMBER
038

DATE
November 2007

TECHNICAL SERVICE BULLETIN

SUBJECT:

2.5L/2.7L (DELTA) ENGINE HESITATION / MIL ILLUMINATION / P0123

This bulletin provides information relating to an engine hesitation or the illumination of the Malfunction Indicator Lamp (MIL) for P0123 (Throttle Position Sensor / Switch "A" Circuit High Input).

Some 2001-2006 Optima (MS) produced between 10-07-2000 ~ 08-31-2005, equipped with the 2.5L or 2.7L (V-6) Delta Engine and some Sportage (KM) models produced between 10-28-2004 ~ 05/18/2007 equipped with the 2.7L (V-6) Delta Engine are applicable for this bulletin. Improper throttle position sensor values may cause the engine to hesitate under loads or cause the illumination of the MIL. To correct for this condition, the throttle position sensor (TPS) has been improved.

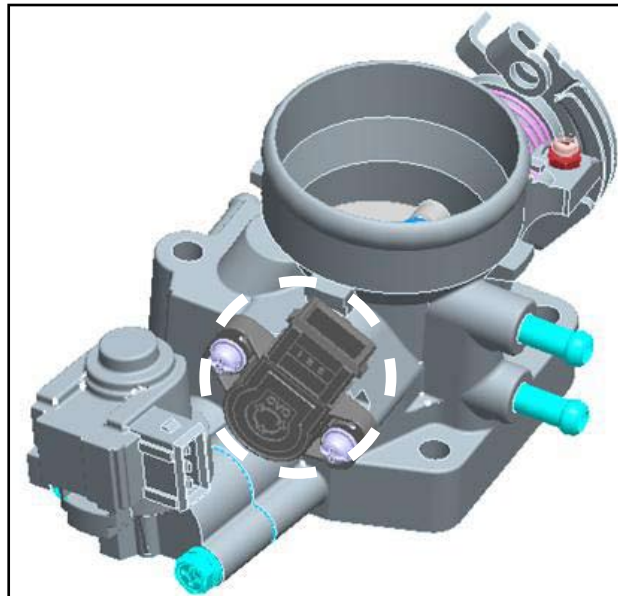

Part Number	
Previous	New
35170 37100	35170-37100FFF

File Under: Engine

- Circulate To: General Manager Service Manager Parts Manager
 Service Advisor(s) Technician(s) Body Shop Manager Fleet Repair

SUBJECT:

2.7L (DELTA) ENGINE HESITATION / MIL ILLUMINATION / P0123

Repair Procedure:

1. Turn the ignition key to the 'Off' position. Open the hood and remove the engine cover. Disconnect the VIS (Variable Induction System) connector and the injector connector if equipped.

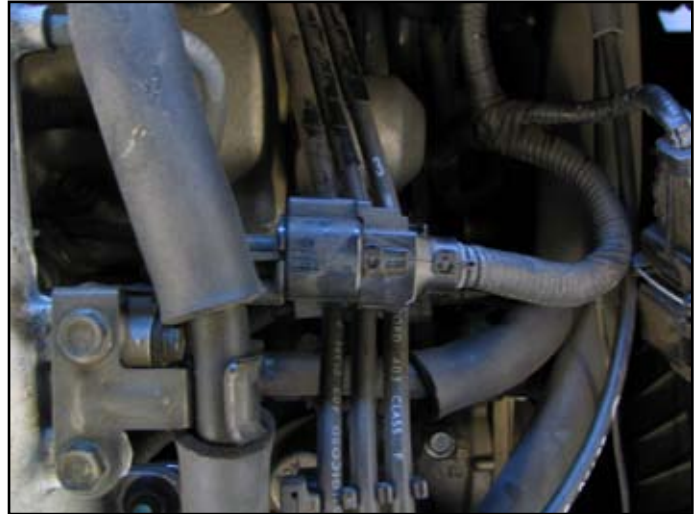

2. Disconnect the idle speed control actuator (ISCA) connector and remove the two retaining bolts. Remove the ISCA and gasket.

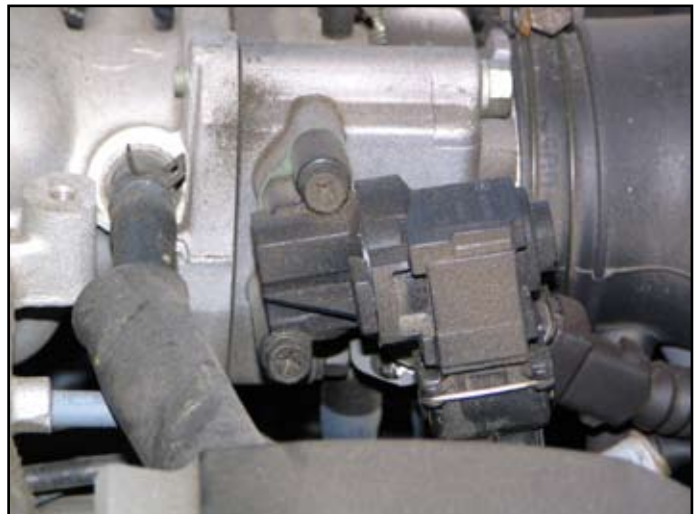

3. Disconnect the throttle position sensor (TPS) connector and remove the two (2) mounting screws.

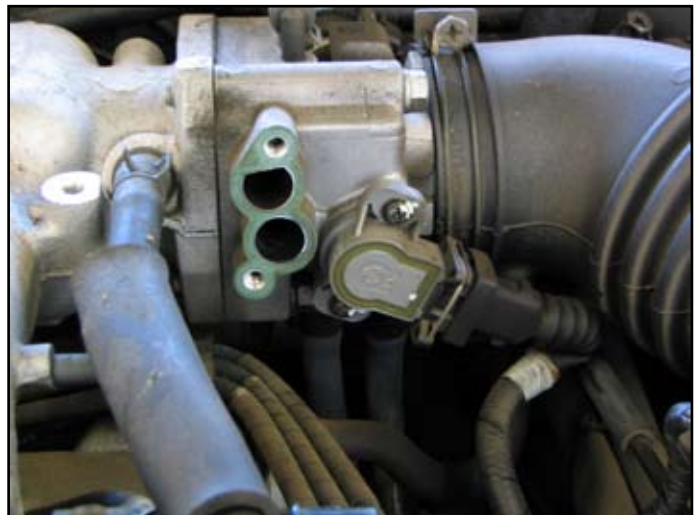

SUBJECT:**2.7L (DELTA) ENGINE HESITATION / MIL ILLUMINATION / P0123**

4. Install the new TPS sensor onto the throttle body and torque the two screws (1.5-2.5Nm / 13.2~21.6 in-lbs), reconnect the TPS connector.



5. Install a new ISCA gasket and re-install the ISCA actuator. Torque the ISCA bolts (6-8 Nm / 52.8~69.6 in-lb), reconnect the ISCA connector. Reconnect the VIS connector and the injector connector if equipped.



6. Reinstall the engine cover.

SUBJECT:

2.7L (DELTA) ENGINE HESITATION / MIL ILLUMINATION / P0123

AFFECTED VEHICLE RANGE:

2001-2006 Optima (MS) equipped with 2.5L / 2.7 (V-6) Delta Engine: (10/01/2000 ~ 8/31/2005)

2005-2007 Sportage (KM) equipped with 2.7L (V-6) Delta Engine:
(10/28/2004~05/18/2007)**PARTS INFORMATION:**

Part Name	Part Number	
	Previous	New
Throttle Position Sensor	35170 37100	35170-37100FFF
Idle Speed Control Actuator Gasket	35156 33271	

WARRANTY CLAIM INFORMATION:

Claim Type	Causal P/N	Qty.	N Code	C Code	Repair Description	Labor Op Code	Time	Related Parts	Qty.
W	35170 37100	1	N03	C32	Throttle Position Sensor, R & R	35102F00	0.3	35170-37100FFF	1