

TECHNICAL BULLETIN
LTB00618NAS4
08 APR 2015



© Jaguar Land Rover North America, LLC

NOTE: The information in Technical Bulletins is intended for use by trained, professional Technicians with the knowledge, tools, and equipment required to do the job properly and safely. It informs these Technicians of conditions that may occur on some vehicles, or provides information that could assist in proper vehicle service. The procedures should not be performed by 'do-it-yourselfers'. If you are not a Retailer, do not assume that a condition described affects your vehicle. Contact an authorized Land Rover service facility to determine whether this bulletin applies to a specific vehicle.

This reissue replaces all previous versions. Please destroy all previous versions.

Changes are highlighted in gray

SECTION: 204-01

'Click' / 'Rattle' Noise From Engine Compartment When Driving

AFFECTED VEHICLE RANGE:

Range Rover Sport (LW)

Model Year: 2014

VIN: EA000002-EA339983

Engine: V8 S/C 5.0L Petrol

Range Rover (LG)

Model Year: 2013-2014

VIN: DA001204-EA152794

Engine: V8 5.0L Petrol
V8 S/C 5.0L Petrol

MARKETS:

NAS

CONDITION SUMMARY:



NOTE: Refer to Service Instruction steps 1 and 2 for typical road surface that will generate the concern.

Situation: A 'click', 'rattle', or 'light vibration' noise may be heard when driving over an irregular road surface (cobble stone, bricks, etc. [see illustrations in Service Instruction steps 1 and 2]) at speeds up to 15 MPH (25 Km/h):

A. A single or multiple 'click' noise from the engine bay during sharp acceleration or braking at a variety of vehicle temperatures and ambient conditions. This noise may also occur during sharp turns to the left or right at speeds of 5-15 MPH (10-25 Km/h).

B. A 'rattle' noise when driving over an irregular road surface (cobble stone, bricks, etc. [see illustrations in Service Instruction steps 1 and 2]) until the road surface changes. The sound may also be described as a light vibration and can occur at any temperature or ambient condition.

Cause: This may be caused by the engine mounts and/or steering gear vibrating causing abnormal noises.



NOTE: Refer to Technical Bulletin LTB00557NAS for assistance in diagnosing front suspension noise.



NOTE: 'Rattle' noise ('B' above) is applicable only to Range Rover Sport (L494; 5.0L SC V8) up to VIN EA308255 and Range Rover (L405; 5.0L NA / SC V8) up to VIN EA133484.



NOTE: Contact the Jaguar Land Rover Technical Helpline before replacing the steering gear.

Action: Should a customer express this concern, follow the Service Instruction outlined below.

PARTS:

LR033201	Bolt - Engine mount (M8 x 60mm)	Quantity: 8 (if required)
LR054850	Mount - Engine	Quantity: 2 (if required)
LR058378	Steering gear - Range Rover Sport (L494) - 2014MY	Quantity: 1
LR058395	Steering gear - Range Rover (L405) - 2013MY	Quantity: 1
LR058396	Steering gear - Range Rover (L405) - 2014MY	Quantity: 1
LR059978	Steering gear washer repair kit - Range Rover (L405)	Quantity: 1
QYG500090	Bolt - Steering coupling (M8 x 30mm)	Quantity: 1 (if required)
TYG500141	Bolt - Front driveshaft (M8 x 48mm)	Quantity: 6 (if required)

TOOLS:

Refer to Workshop Manual for any required special tools.

WARRANTY:

 **NOTE: Repair procedures are under constant review, and therefore times are subject to change; those quoted here must be taken as guidance only. Always refer to TOPIx to obtain the latest repair time.**

 **NOTE: DDW requires the use of causal part numbers. Labor only claims must show the causal part number with a quantity of zero.**

DESCRIPTION	SRO	TIME (HOURS)	CONDITION CODE	CAUSAL PART
Engine mountings - Front - Set - Renew - Range Rover Sport (L494) 5.0L SC V8	12.45.20	3.8	42	LR051515
Engine mountings - Front - Set - Renew - Range Rover (L405) 5.0L NA V8	12.45.20	3.7	42	LR051515
Engine mountings - Front - Set - Renew - Range Rover (L405) 5.0L SC V8	12.45.20	3.9	42	LR051515
Steering gear - Renew - Range Rover Sport (L494) without Adaptive Damping	57.10.01	1.6	42	LR049076
Steering gear - Renew - Range Rover Sport (L494) with Adaptive Damping	57.10.01.46	1.7	42	LR049076
Steering gear - Renew - Range Rover (L405) up to 14MY without Adaptive Damping	57.10.01	1.8	42	LR049076
Steering gear - Renew - Range Rover (L405) from 14MY without Adaptive Damping	57.10.01	1.6	42	LR046039
Steering gear - Renew - Range Rover (L405) up to 14MY with Adaptive Damping	57.10.01.46	2.0	42	LR049076
Steering gear - Renew - Range Rover (L405) from 14MY with Adaptive Damping	57.10.01.46	1.8	42	LR046039
Steering gear washer kit - Install - Range Rover (L405)	57.33.89.26	0.6	42	LR059978

 **NOTE: Normal Warranty procedures apply.**

SERVICE INSTRUCTION:

1. Typical road surface that can generate the 'rattle' sound.

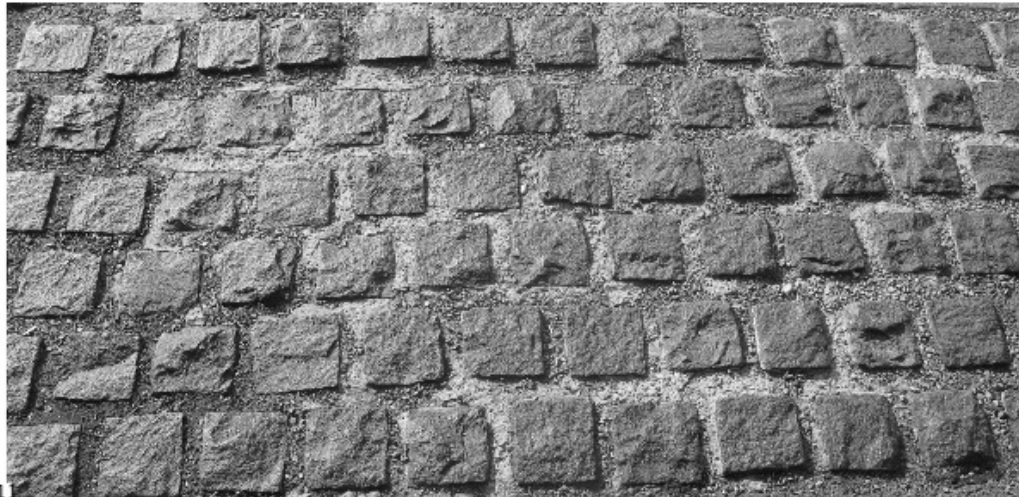

E15961

2. Typical road surface that can generate the

'rattle'
sound.



E162100

3. Install new left and right engine mountings (see TOPIX Workshop Manual, Section 303-01).

4. Carry out a test drive.

- If the noise is no longer present, return the vehicle to the customer.
- If the noise is present:
 - **Range Rover (L405):** continue to step 5.
 - **Range Rover Sport (L494):** continue to step 17.

Steps 5-16: Range Rover (L405) vehicles ONLY

5.  **CAUTION: Make sure the area around the component is clean and free of foreign material.**

Remove the engine undershield (see TOPIX Workshop Manual, section 501-02).

6.  **CAUTION: Make sure the area around the component is clean and free of foreign material.**

 **NOTE: A single 4mm washer is supplied per vehicle. Only install the 4mm washer on the pinion side of the steering gear.**

Remove and discard the support bracket and the retaining bolts.

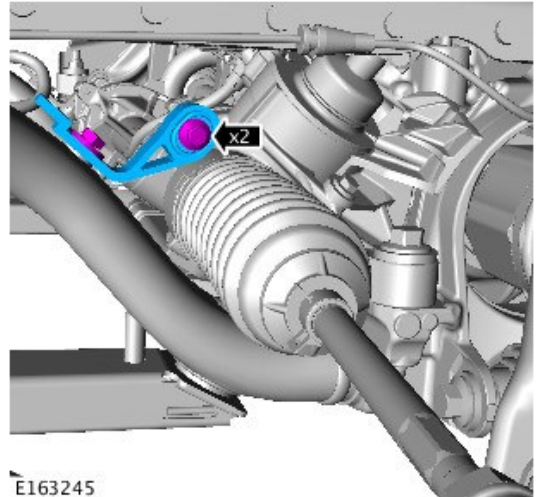

7. Remove and discard the steering gear retaining bolt.

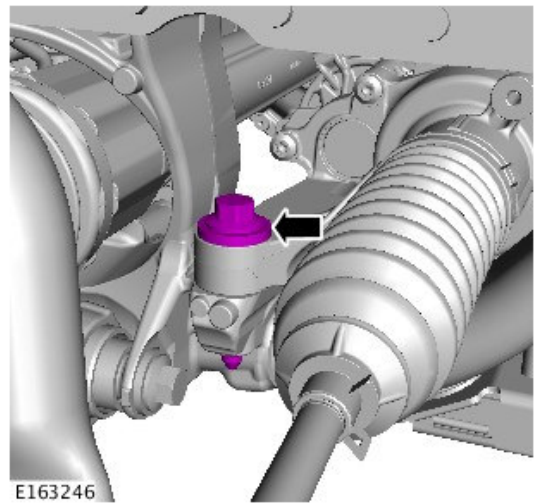

8. Remove and discard the steering gear retaining bolt.

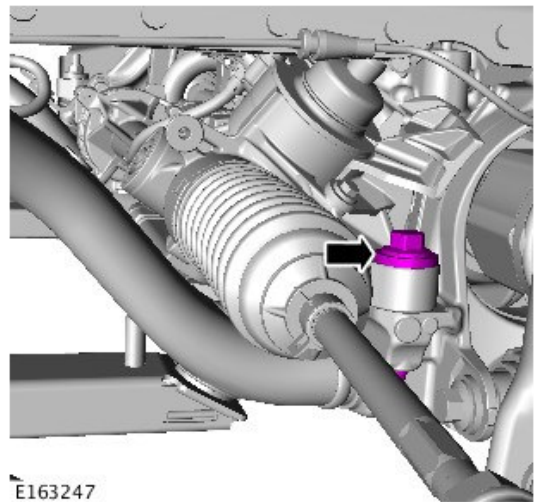

9. Remove and discard the mass damper retaining bolt.

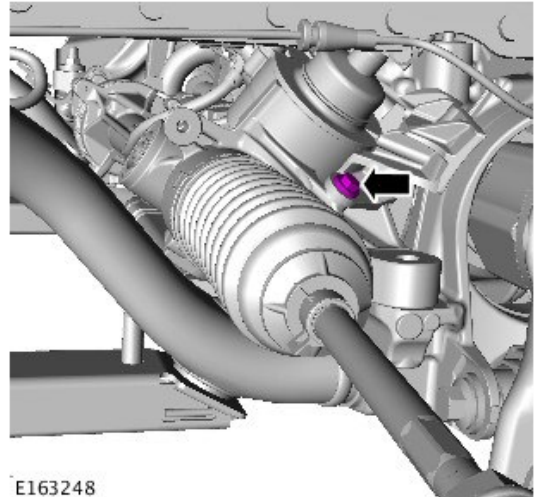

E163248

10. Position the steering gear to one side.

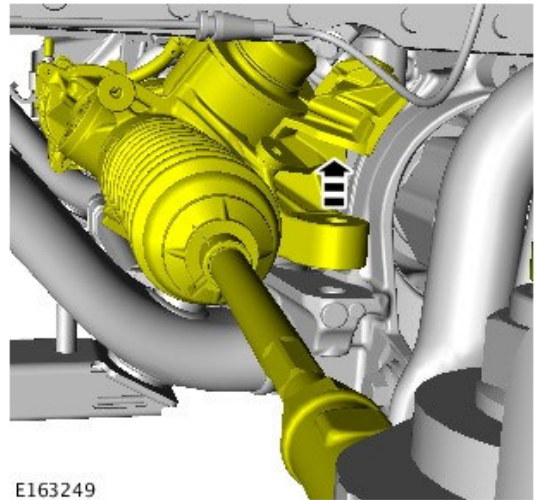

E163249

11. Remove and discard the mass damper.

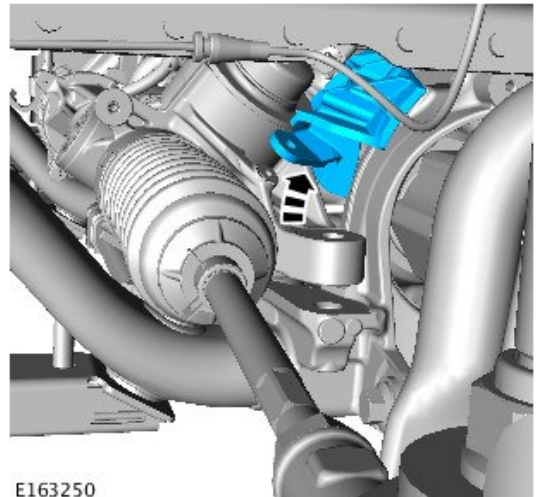

E163250

12.  **NOTE: The supplied 4mm washers must be installed as shown.**

-  **NOTE: Do not tighten the steering gear retaining bolt fully at this stage.**

Install the 90mm steering gear retaining bolt and 4mm washers.

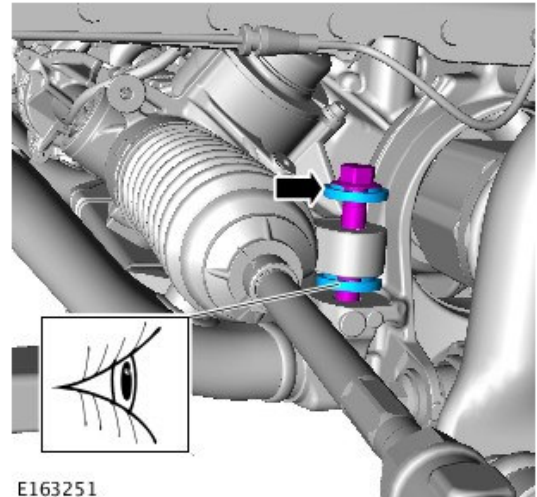

13. Install the 75mm steering gear retaining bolt.

- Torque: 100Nm + 240°

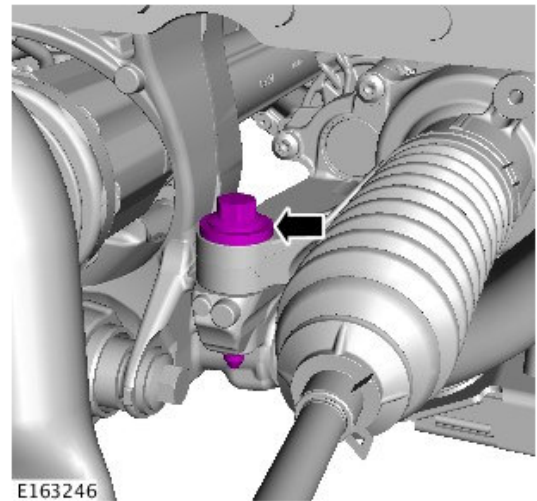

14. Tighten the steering gear retaining bolt.

- Torque: 100Nm + 240°

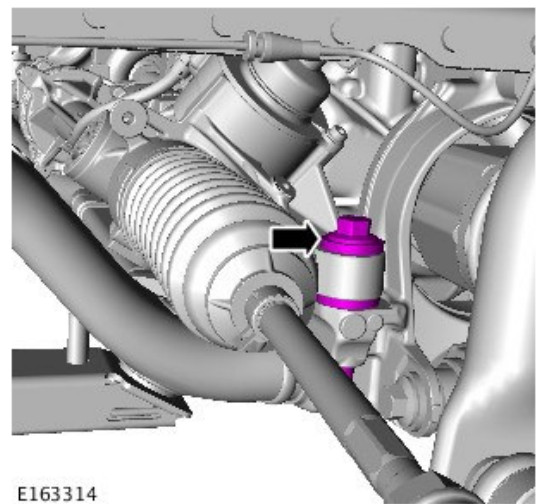

15. Install the engine undershield (see TOPIX Workshop Manual, section 501-02).

16. Carry out a test drive.

- If the noise is no longer present, return the vehicle to the customer.
- If the noise is present, continue to step 17.

Steps 17-20: All vehicles only if not repaired in steps 1-16.

17. Refer to Technical Bulletin LTB00557NAS.

- If the noise is not the same as described in Technical Bulletin LTB00557NAS, continue to step 18.
- If the noise is the same as described in Technical Bulletin LTB00557NAS, follow the Service Instruction contained within Technical Bulletin LTB00557NAS.

18. Install a new steering gear (see TOPIX Workshop Manual, section 204-00).

19. Carry out a test drive.

- If the noise is no longer present, return the vehicle to the customer.
- If the noise is present, refer to Technical Bulletin LTB00557NAS to confirm there is no other potential noise sources that could be causing the reported symptom.

20. If all possible repair work has been carried out but the concern still remains, contact the Jaguar Land Rover Technical HelpLine, detailing the symptom and all repair work carried out.