

TECHNICAL BULLETIN

LTB00513

15 JAN 2013



© Jaguar Land Rover Limited
All rights reserved.

SECTION: 303-04B

4.4 TDV8 Exhaust Smoke

AFFECTED VEHICLE RANGE:

Range Rover (LM)

Model Year: 2011-2012

VIN: BA334433-CA393639

MARKETS:

All Diesel Markets

CONDITION SUMMARY:

Situation:

A customer may report a concern of excessive exhaust smoke. On vehicles equipped with a diesel particulate filter (DPF) the customer may also complain that "DPF Full Visit Dealer" message is shown in the instrument cluster message centre without any prior DPF warning messages (for example - "DPF Full See Handbook").



NOTE: To avoid any potential damage to the vehicle, it is imperative that every step of this Bulletin is followed in its entirety.



NOTE: A smoke test on the charge air system is advised to make sure that no small boost air leaks are evident on the various joints in the system. A small boost air leak could adversely affect the pressure across the turbo centre bearing leading to oil seeping past the turbo seals.



NOTE: Any other faults found, i.e. via the smoke test are to be claimed as a separate Warranty Claim.



NOTE: The drain pipe kit is available in limited supply and must only be ordered for vehicles which are actually in the Dealership awaiting repair. These parts must not be ordered and kept as a stock item. Any large order quantities will be automatically cancelled.



NOTE: Special tool 310-197 (fuel injector remover) will be required - this is a mandatory tool so all dealerships should have this tool readily available, the tool will be used to aid removal of the two core plugs detailed in steps 18, 19 and 20

Cause: Ineffective oil drainage system. Suggested Customer Concern Code - D50.

Action: Should a customer express concern, follow the Service Instruction outlined below.

PARTS:



NOTE: 1 Litre of engine oil to be sourced locally and claimed under ZZZ001.

LR045004

Drain pipe kit

Quantity: 1

TOOLS:

Remover, Fuel Injector
310-197



E114526

WARRANTY:



NOTE: Repair procedures are under constant review, and therefore times are subject to change; those quoted here must be taken as guidance only. Always refer to TOPIx to obtain the **latest repair time**.



NOTE: DDW requires the use of causal part numbers. Labor only claims must show the causal part number with a quantity of zero.

DESCRIPTION	SRO	TIME (HOURS)	CONDITION CODE	CAUSAL PART
Install modified drain tube	19.42.89/44	8.2	42	LR022781
Using SDD carry out a DPF regeneration	17.50.30	0.5	42	LR022781
Carry out a 20 minute road test	10.41.17	0.3	42	LR022781



NOTE: Normal Warranty policies and procedures apply.

SERVICE INSTRUCTION:



NOTE: This procedure requires an M14 x 2mm long shanked tap and a 12mm drill bit capable of drilling to a depth of 85mm.

1. Identify the new design oil drain pipe supplied in the parts kit.



E151559

2. Identify the oil drain tube supplied in the parts kit.



E149678

3. Identify the drill guide supplied in the parts kit.



E149682

4. Identify the swarf tool supplied in the parts kit.



E149737

5. Identify the new core plug supplied in the parts kit.



E149680

6.  NOTE: If required, the tap can be purchased from Cromwell Tools which have branches throughout the UK and Worldwide. Please visit their website for further details www.cromwell.co.uk and in the search catalogue box enter the following then click search - "14x2.00mm long shank taper tap". For the UK Market you can also place an order by contacting Cromwell Tools Coventry on + 44 (0) 2476 664614 or contact your local branch direct. A list of local branches can be found on the Cromwell website in the top right hand corner of the homepage. Overseas Markets can order via Cromwell Tools if required or via a local engineering tool supplier in the Market.

Identify the M14 x 2mm long shanked taper tap sourced locally.



E149679

7.  NOTE: The 12mm drill bit must be capable of drilling to a depth of 85mm.

 NOTE: If required a 12mm drill bit can be purchased from Cromwell Tools which have branches throughout the UK and Worldwide. Please visit their website for further details www.cromwell.co.uk and in the search catalogue box enter the following then click search - "SHR0250189A". For overseas Markets the drill bit can be sourced locally via a local engineering tool supplier in the Market.

 NOTE: A drill with a chuck capacity of at least 12mm will be required if the drill bit is purchased from Cromwell Tools (most standard drills have a chuck capacity of 10mm, although drills with a

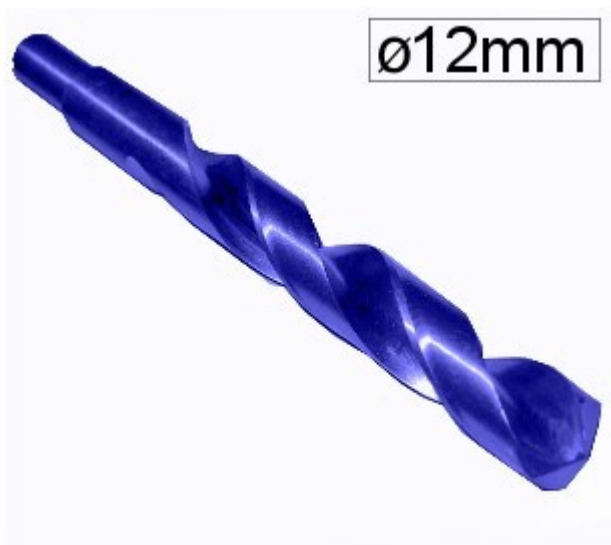

E150239

chuck capacity of 13mm are readily available at any reputable DIY store).



NOTE: For information, the drill bit used for the validation work at Land Rover was a Dewalt HSS Impact Drill Bit 12mm, model number DT50618-QZ (this drill bit is readily available via local DIY stores. i.e. Screwfix/Machine Mart). Although this is a 12mm drill bit the end of the drill has been turned down to allow fitment to a standard 10mm drill chuck.

Identify the 12mm drill bit sourced locally.



8. NOTE: To remove the two core plugs from the sump as detailed in steps 18, 19 and 20 it is recommended that a self drilling screw, that is 45mm in length and which has a drill tip diameter of 5.5mm (thread diameter 6.3mm) is used for this procedure. The self drilling screw can be purchased from a DIY store, i.e. Screwfix for the UK Market (Product Code: 41645). For overseas Markets the self drilling screw should be sourced from a local store within the Market.

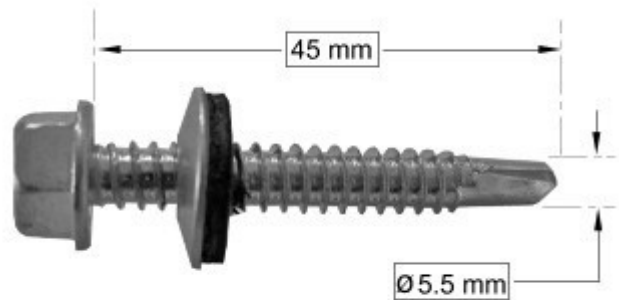

Identify the self drilling screw sourced locally.

E152205



9. CAUTION: Make sure that all fluid line openings have suitable blanking caps installed.



CAUTION: Apply a suitable protective cover over the subframe to protect against swarf and oil.

Remove the front subframe (see TOPIx Workshop Manual, section 502-00).



10. NOTE: Make sure that the mating faces are clean and free from debris.

Drain the engine oil from the mini-sump.

- z Position a container to collect fluid loss.
- z Remove the sump plug.
- z Allow the oil to drain from the mini-sump.
- z Install the sump plug and tighten to 23 Nm.

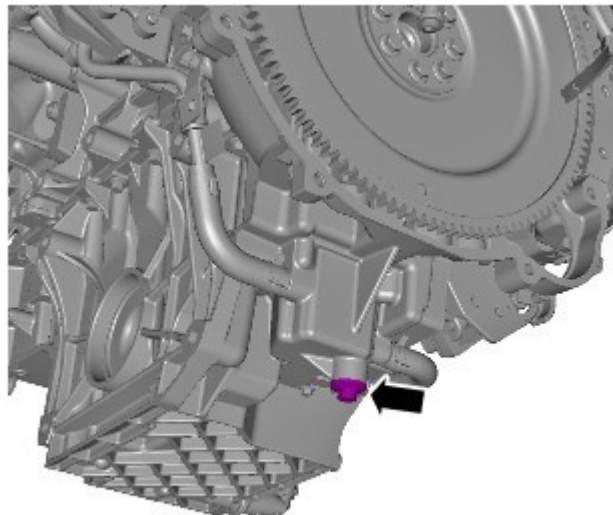

E 151674

11. Release the hose from the charge air cooler and allow any fluid to drain.

- z Position a container to collect fluid loss.
- z Release the clip.

- z Remove the 3 bolts.



12. Remove the front driveshaft joint shield.

- z Remove the 2 Torx bolts.
- z Remove the nut.

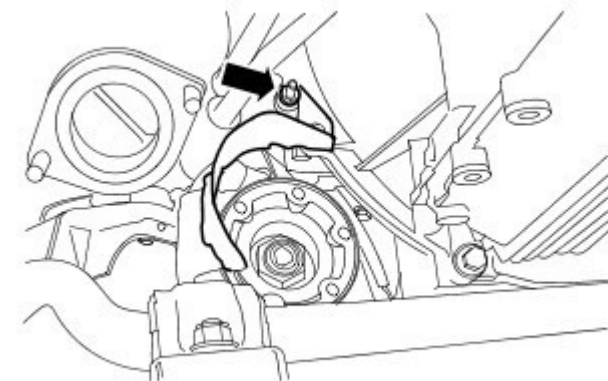
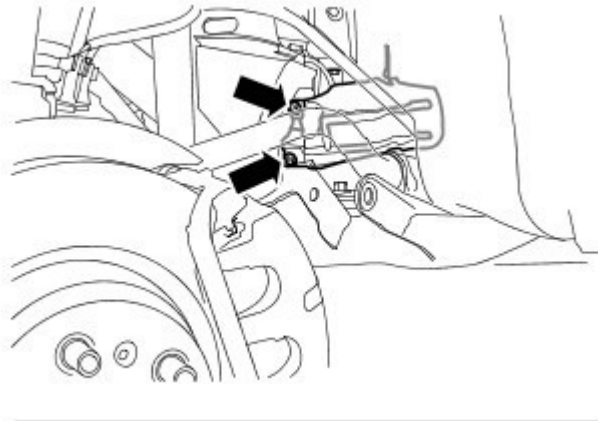

E77807

13.  **CAUTION:** Mark the position of the driveshaft flange in relation to the drive pinion flange.

Release the front driveshaft from the axle assembly.

- z Remove and discard the 6 bolts.
- z Using a suitable tie strap, support the driveshaft.

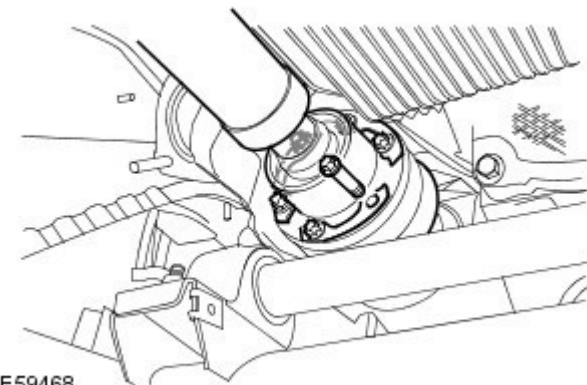

E59468

14. Remove the differential.

- z Disconnect the differential breather line.

- z Remove the 4 bolts.

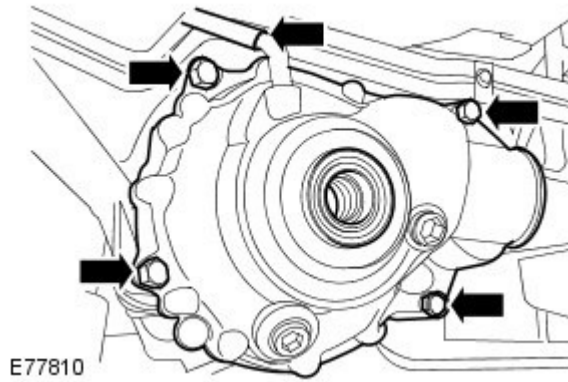

15. Release the transmission fluid lines.

- z Remove the bolt.

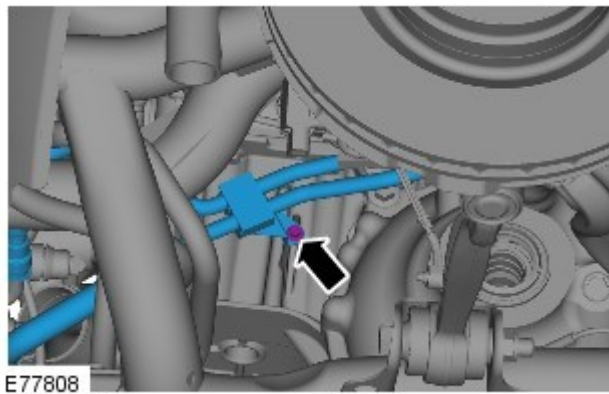

16. Remove and discard the old design oil drain pipe.

- z Position a container to collect fluid loss.
- z Remove the 3 Torx bolts.
- z Release the clip.
- z Remove and discard the gasket.

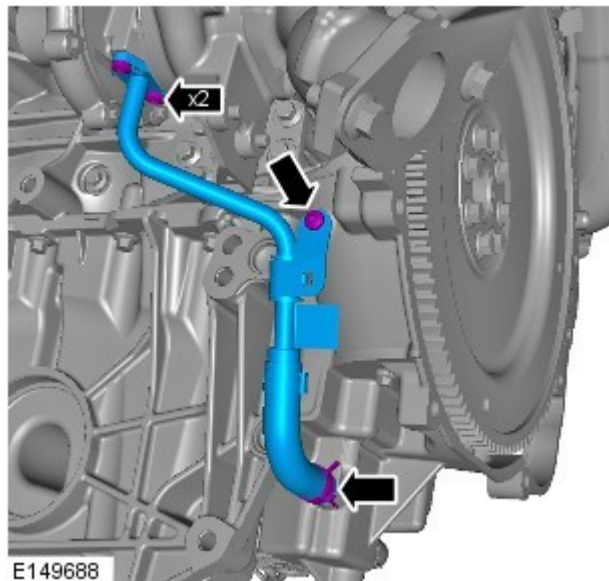

17.  NOTE: Re-position the core plugs inwards by 1mm to break the sealant bond on the core plugs.

Identify the 2 core plugs.

- z Using a suitable tool, carefully shock the upper core plug to break the sealant bond between the core plug and the oil pan.
- z Repeat to the lower core plug.

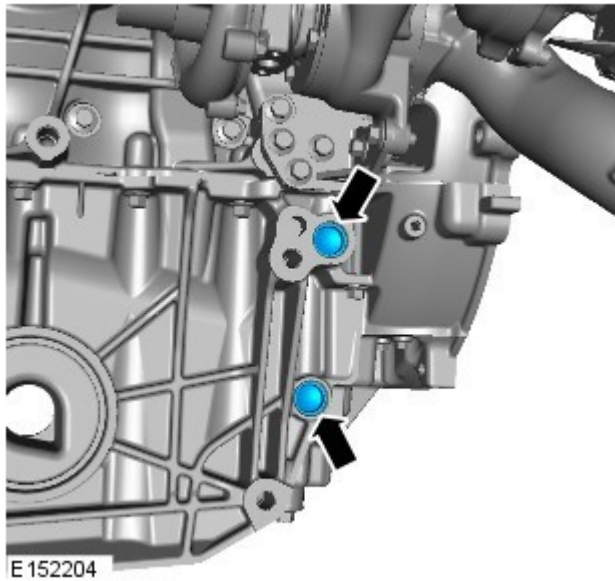

18.  NOTE: 13MY Range Rover shown, up to end of 12MY Range Rover similar.

Using a suitable drill and drill bit, drill a 4.5mm hole in the centre of the upper core plug.

- z Position a container to collect fluid loss.
- z Repeat to the lower core plug.

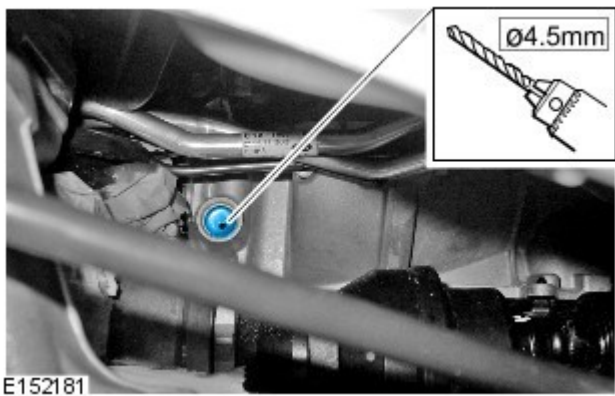

19.  NOTE: 13MY Range Rover shown, up to end of 12MY Range Rover similar.

 NOTE: Make sure that the washer on the screw is positioned far enough away from the head to allow the connection of the slide hammer.

Using a suitable tool, install the self drilling screw to the position shown.

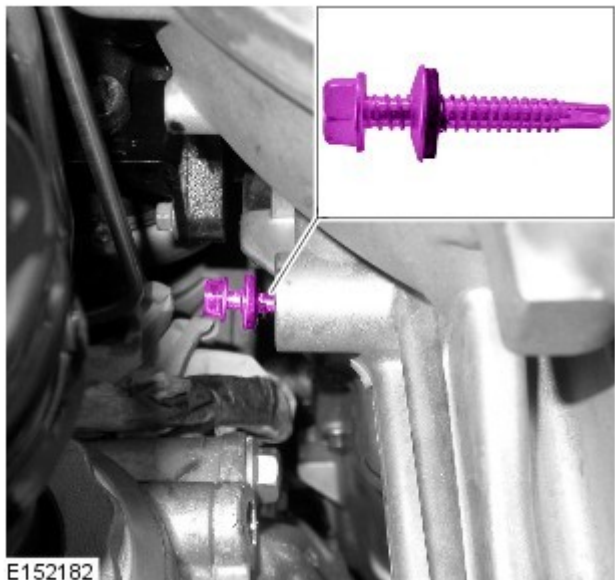

20.  NOTE: 13MY Range Rover shown, up to end of 12MY Range Rover similar.

Using the special tool 310-197, remove and discard the core plug.

- z Repeat steps 19 and 20 to the lower core plug.

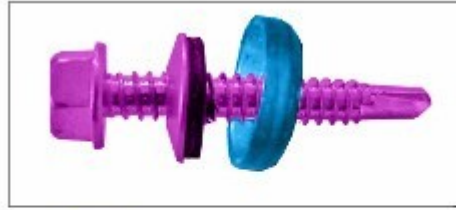



- 21.  CAUTION: Make sure that the holes are clean and free from burrs.

 CAUTION: Make sure that the end of the swarf tool with the shorter length is inserted in to the lower hole.

 CAUTION: Make sure that the swarf tool is fully inserted in to the lower hole. Failure to follow this instruction may result in damage to the vehicle.

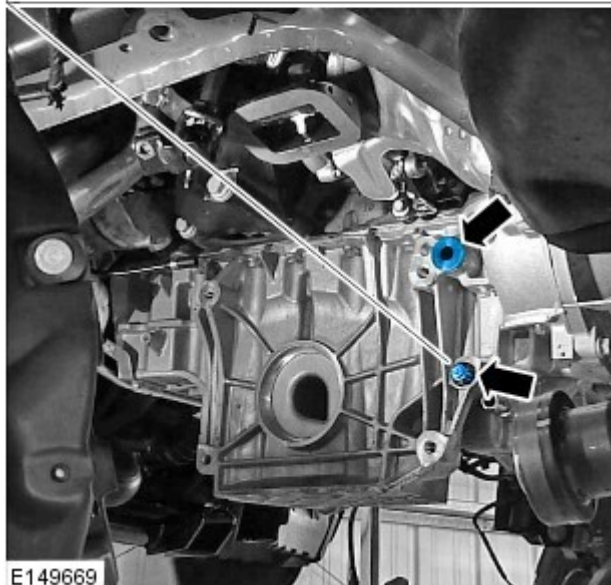
Install the drill guide and swarf tool in the positions shown.



- 22.  CAUTION: Make sure that the transmission fluid lines are not damaged

during this step.

 **CAUTION:** Make sure that the swarf tool remains fully inserted during the drilling process.

 **CAUTION:** Make sure that the end of the drill bit is coated in grease to help prevent swarf entering the oil pan.

Using a suitable drill and a 12mm drill bit, drill through the centre of the drill guide in to the oil pan until the drill bit breaks through the inner wall of the oil pan, (resistance will no longer be felt on the drill once the inner wall has been broken through).

- z Carefully re-position the transmission fluid lines for access.
- z Position a container to collect fluid loss.
- z Apply a suitable grease to the tip of the drill bit.
- z Remove the drill every 60 seconds and re-apply grease to the tip of the drill bit.

23.  **CAUTION:** Make sure that the end of the tap is coated in grease to help prevent swarf entering the oil pan.

 **CAUTION:** Make sure that the thread is fully cut in the hole. Failure to follow this instruction may prevent the oil drain pipe from being correctly installed.

Tap a thread in the drilled hole.

- z Remove the drill guide.
- z Install the tap to the drill guide.
- z Apply a suitable grease to the tip of the tap.
- z Install the tap and drill guide assembly to the upper core plug hole.
- z Carefully tap the new thread.
- z Remove the tap and drill guide assembly.

24.  **CAUTION:** Make sure that the swarf tool is not removed by more than 15mm during this step. Failure to follow this instruction may result in damage to the vehicle. The swarf tool acts as a sealing plug, removing by more than 15mm may allow swarf fragments to enter the engine oil pan.

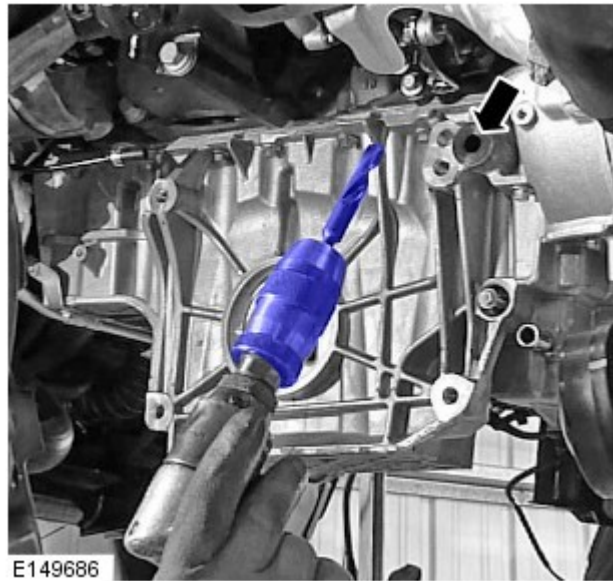

 **NOTE:** The swarf tool is not magnetic as the oil pan assembly is of aluminium construction which is not a ferrous metal, only ferrous metals can be magnetised.

Carefully slide the swarf tool in and out until the swarf has been washed away by the engine oil.

- z Position a container to collect fluid loss.
- z Continue to slide the swarf tool in and out 15mm until the swarf has been removed.
- z Slide the swarf tool in to the fully inserted position.

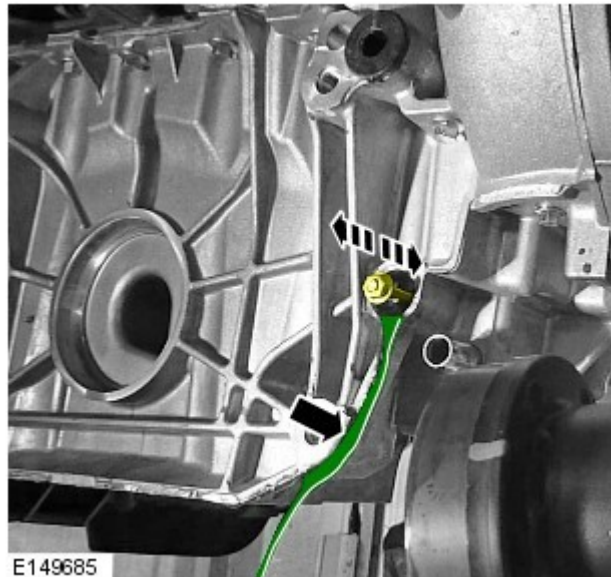

25.  **CAUTION:** Make sure that the swarf tool remains fully inserted during this step.

Using a suitable cleaning fluid with a straw (for example Land Rover General Purpose Cleaner/Brake Cleaner part number STC50544), clean any remaining swarf from the upper core plug hole.

- z Position a container to collect fluid loss.
- z Bend the straw to enable access to the chamber shown.
- z Carefully spray the cleaning fluid down the chamber until all of the swarf is removed.
- z Repeat steps 24 and 25 until all of the swarf and debris are removed.

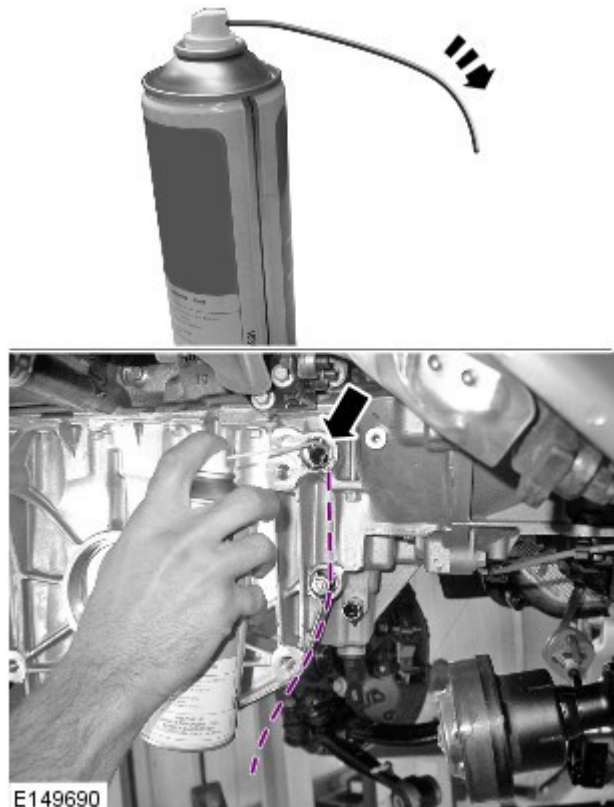

26.  **CAUTION:** Make sure that the end of the tap is coated in grease to help prevent swarf entering the oil pan.

Using the tap and drill guide, make sure that the thread is free from swarf and debris.

- z Install the tap to the drill guide.
- z Apply a suitable grease to the tip of the tap.
- z Install the tap and drill guide assembly to the upper core plug hole.

- z Carefully run the tap through the new thread.
- z Remove the tap and drill guide assembly.



E149670

27.  CAUTION: Make sure that the o-ring seal located on the oil drain tube is lubricated before installation.

 CAUTION: Make sure that the mating surfaces are clean and free from burrs or debris.

 CAUTION: Make sure that the o-ring seal is not damaged during installation.

 CAUTION: If the oil drain tube appears to be tight when installing, repeat the tapping process and make sure that the thread is fully cut in the hole.

Install the oil drain tube.

- z Apply a film of engine oil to the o-ring seal.
- z Using a suitable 8mm Allen key, install the oil drain tube and tighten until it is flush against the oil pan.
- z Remove the swarf tool.

28.  CAUTION: Make sure that sealant is applied to the core plug before installation.

 CAUTION: Make sure that the mating surfaces are clean and free from burrs or

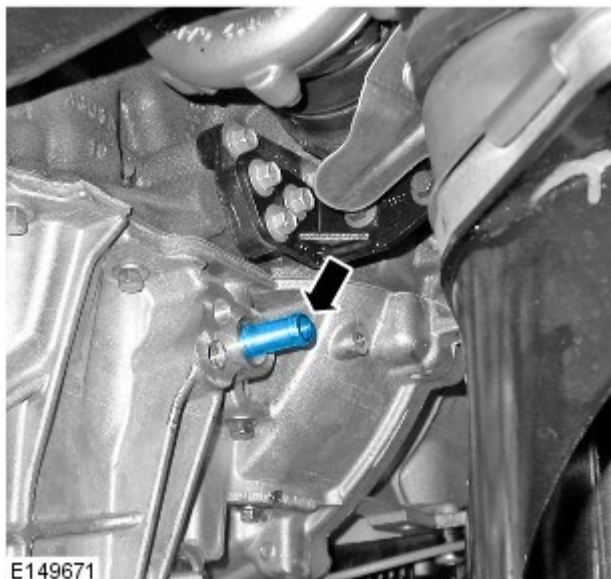

E149671

debris.

 **CAUTION:** Make sure that the core plug is installed by applying force to the outer edge of the core plug, do not apply force to the centre of the core plug.

 **NOTE:** Loctite 648 is readily available worldwide and if necessary can also be purchased from Cromwell Tools in either 50ml or 250ml bottles.

Using a suitable tool, install the new core plug.

- z Apply a continuous bead of locally sourced sealant (for example Loctite 648) around the outer edge of the core plug.

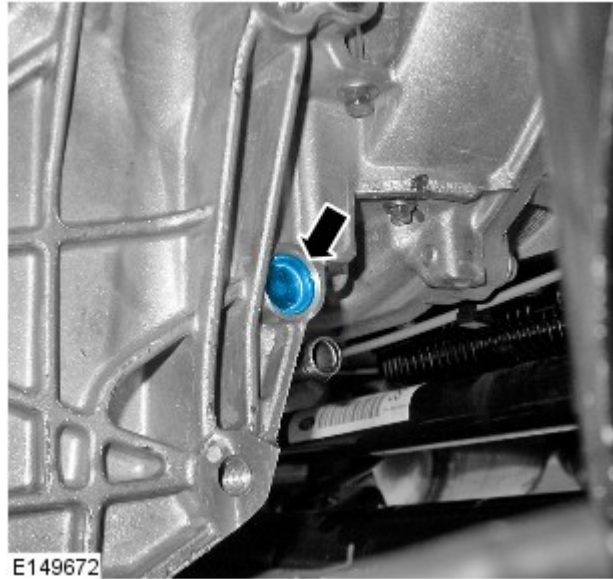

29. Using a suitable tool, remove and discard the section of the heat shield.

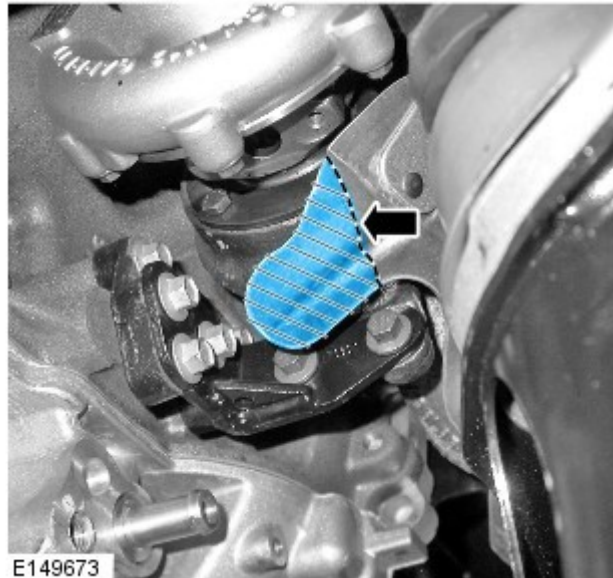

30.  **CAUTION:** Make sure that the turbocharger support bracket is in the uppermost position. Failure to follow this instruction may result in damage to the vehicle.

Re-position the turbocharger support bracket upwards.

- z Slacken the 5 bolts.
- z Push the bracket fully upwards.
- z Tighten the 5 bolts to 23 Nm.

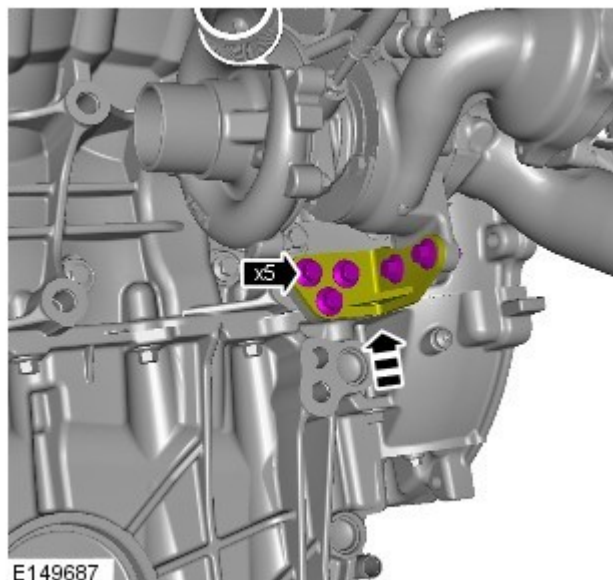

31. Make sure that the 2 clips are installed on to the new design oil drain pipe before installing the oil drain pipe.





32.  CAUTION: Make sure that the mating surfaces are clean and free from debris.

-  CAUTION: Make sure that the 2 hoses are positioned correctly on to the sump before tightening the 2 Torx bolts.

Secure the new design oil drain pipe.

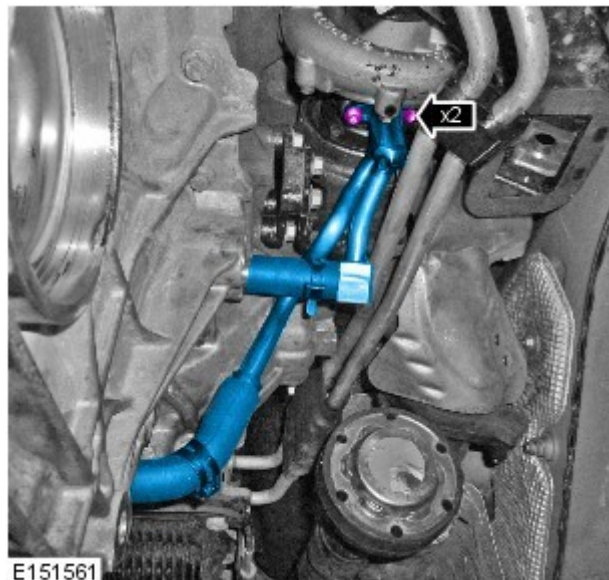
- z Install a new gasket.
- z Tighten the 2 Torx bolts to 10 Nm.



33.  CAUTION: Make sure that the upper clip is in the position shown. Failure to follow this instruction may prevent the correct installation of the differential.

Secure the oil drain hoses.

- z Using a suitable tool secure the 2 clips in the position shown.
- z Tighten the Torx bolt to 10 Nm.

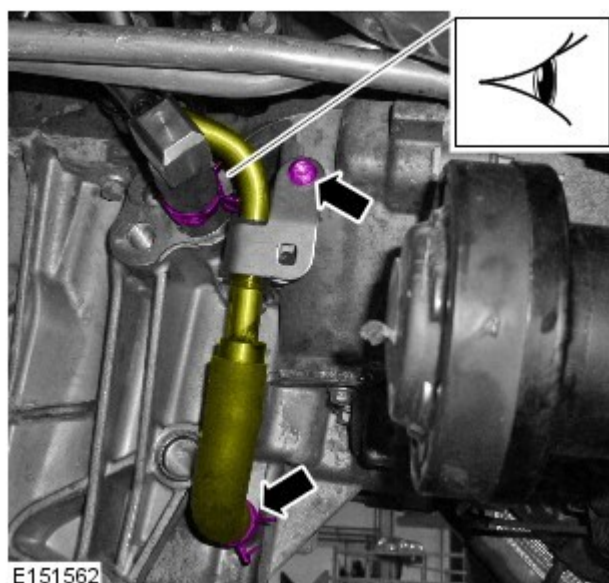

34. Secure the transmission fluid lines.

- z Tighten the bolt to 7 Nm.

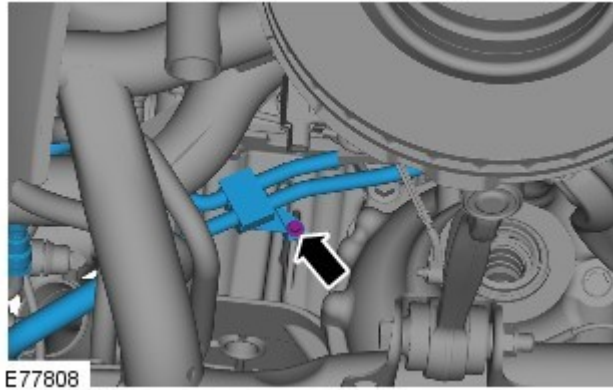

35.  CAUTION: Make sure that the o-ring seal is lubricated prior to installation.

With the aid of another technician, install the differential.

- z Install new o-ring seal.
- z Install the 4 bolts.
- z Stage 1 - Tighten the 4 bolts to 50 Nm.
- z Stage 2 - Tighten the 100mm length bolts a further 90 degrees.
- z Stage 3 - Tighten the 55 mm length bolts a further 60 degrees.
- z Connect the breather pipe.

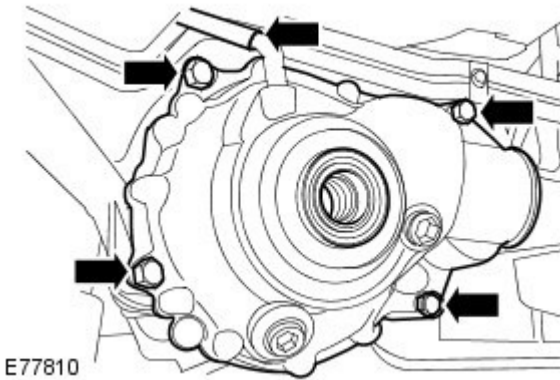

36. Secure the driveshaft to the differential.

- z Stage 1 - Tighten the bolts to 45 Nm
- z Stage 2 - Tighten a further 90 degrees.

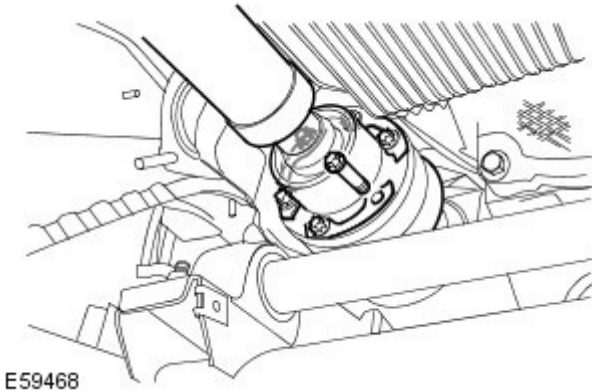

37. Install the front driveshaft joint shield.

- z Tighten the 2 Torx bolts to 3 Nm.
- z Tighten the nut to 10 Nm.

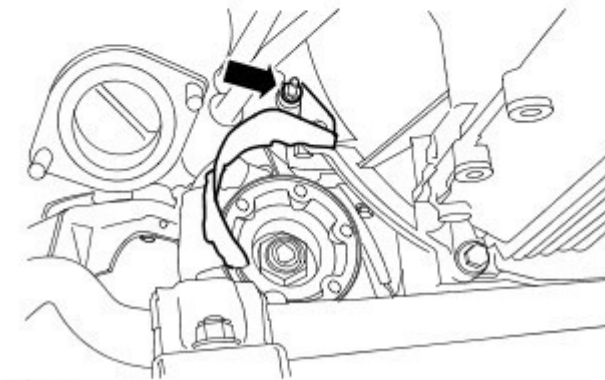
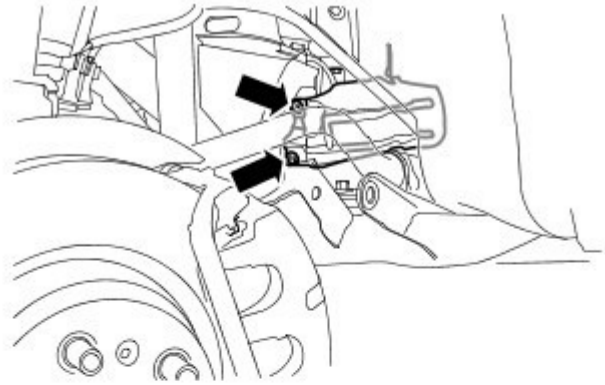

E77807

38. Secure the hose to the charge air cooler.

- z Using a suitable cloth, wipe away any remaining fluid.
- z Secure the clip.
- z Tighten the 3 bolts to 10 Nm.



39. Install the front subframe (see TOPIx Workshop Manual, section 502-00)

40. Check the engine oil level and top up if required.

41. Check the front wheel alignment and adjust if required (see TOPIx Workshop Manual, section 204-00)

All Vehicles

42.  **NOTE:** Please make sure the road test is carried out in sport mode keeping the engine speed above 2600rpm for as much of the road test as possible, this will ensure bi turbo mode (secondary turbo operational) is being utilised.

On completion of the repair the vehicle should be taken on a 20 minute road test to clear any residual oil which is left in the system.

EU5 DPF vehicles only

43. On completion of the 20 minute road test as detailed in step 42, the engine should be left idling for a further 20 minutes (during this time SDD can be prepared).
44. Using SDD carry out a DPF regeneration, follow all on screen instructions.