

MIL "ON" DTC P0300, P0301, P0302, P0303, P0304, P0305, or P0306

Service Category Engine/Hybrid System

Section Engine Control

Market USA

Lexus Supports
ASE Certification 

Applicability

YEAR(S)	MODEL(S)	ADDITIONAL INFORMATION
2006	GS300	

TSIB REVISION NOTICE

May 13, 2010 Rev1:

- A step has been added at the end of the Repair Procedure requiring the completion of TSIB [L-SB-0030-10](#) to complete the overall repair.

Any previous printed versions of this service bulletin should be discarded.

Introduction

Some 2006 model year GS 300 vehicles may exhibit a MIL "ON" condition with one or more of the following Diagnostic Trouble Codes (DTCs):

- P0300 – Random Misfire Detected
- P0301 – Cylinder 1 Misfire Detected
- P0302 – Cylinder 2 Misfire Detected
- P0303 – Cylinder 3 Misfire Detected
- P0304 – Cylinder 4 Misfire Detected
- P0305 – Cylinder 5 Misfire Detected
- P0306 – Cylinder 6 Misfire Detected

The valve springs have been improved to prevent any of the above DTCs from occurring. Use the following repair procedures to address customer concerns.

MIL "ON" DTC P0300, P0301, P0302, P0303, P0304, P0305, or P0306

Production Change Information

This TSIB applies to vehicles produced **BEFORE** the Production Change Effective VINs shown below.

MODEL	DRIVETRAIN	PRODUCTION CHANGE EFFECTIVE VIN
GS 300	2WD	JTHBH96S#65027366
	AWD	JTHCH96S#60014171

Warranty Information

OP CODE	DESCRIPTION	TIME	OFF	T1	T2
EG8033	R & R All Valve Springs and Valve Spring Retainers	8.0	90501-33018 90501-33019	8A	99

APPLICABLE WARRANTY

- This repair is covered under the Lexus Powertrain Warranty. This warranty is in effect for 72 months or 70,000 miles, whichever occurs first, from the vehicle's in-service date.
- Warranty application is limited to occurrence of the specified condition described in this bulletin.

Parts Information

PREVIOUS PART NUMBER	CURRENT PART NUMBER	PART NAME	QTY
90501-33018	90501-30030	Valve Spring	24
90501-33019			
13741-20021	13741-31020	Valve Retainer	24
90430-16012	Same	Gasket, Oil Pipe	4
90430-16016	Same		2
11328-31030	Same	Gasket, Timing Gear Cover	1
11159-31010	11159-0P010	Gasket, Camshaft Bearing Cap	4
90430-10024	90430-A0001		2
23915-46011	Same	Fuel Pump Insulator	1
11214-31020	Same	Gasket, Cylinder Head Cover No. 2	1
11213-31040	Same	Gasket, Cylinder Head Cover	1
17176-31020	Same	Gasket, Air Surge Tank to Intake Manifold	1

MIL "ON" DTC P0300, P0301, P0302, P0303, P0304, P0305, or P0306

Required Tools & Equipment

REQUIRED EQUIPMENT	SUPPLIER	PART NUMBER	QTY
TIS Techstream* or Techstream Lite NOTE: Software version 5.00.028 or later is required.	ADE	TSPKG1 or TSLITEDLR01	1

* Essential SST.

NOTE
Additional TIS Techstream or Techstream Lite units may be ordered by calling Approved Dealer Equipment (ADE) at 1-800-368-6787.

TOOLS AND MATERIAL	QTY
Toyota General Adhesive 1344, Three Bond 1344, or Equivalent	As Needed
FIPG Sealant: P/N 08826-00080, or Equivalent	As Needed
ILSAC GF-4 Multi-grade SAE 5W-30	1 qt (As Needed for Fuel Pump)
Anti-rotation Tool, or Equivalent	1
Air Lead Pipe, or Equivalent	1
Valve Spring Removal Tool, or Equivalent	1

MIL "ON" DTC P0300, P0301, P0302, P0303, P0304, P0305, or P0306

Inspection Procedure

NOTE

TSIB [L-SB-0030-10](#), "MIL 'ON' DTC P030# and/or Intermittently Runs Rough" MUST be performed after the procedures in this bulletin to complete the overall repair.

1. Using TIS Techstream, verify that one or more of the following DTCs are stored:
 - P0300 Random Misfire Detected
 - P0301 Cylinder 1 Misfire Detected
 - P0302 Cylinder 2 Misfire Detected
 - P0303 Cylinder 3 Misfire Detected
 - P0304 Cylinder 4 Misfire Detected
 - P0305 Cylinder 5 Misfire Detected
 - P0306 Cylinder 6 Misfire Detected

NOTE

If any other DTCs are present, refer to the Repair Manual for diagnostic information as this TSIB does NOT apply.

2. Perform misfire diagnosis.

Refer to the Technical Information System (TIS), 2006 model year GS 300 Repair Manual, *Engine/Hybrid System – Engine Control – ["3GR-FSE Engine Control System: SFI System: P0300: Random/Multiple Cylinder Misfire Detected"](#)*

NOTE

Normal mechanical engine condition, engine control system, fuel supply/injection systems, and ignition system operation must be present or this TSIB does NOT apply.

3. If the concern is not resolved after following the Repair Manual misfire diagnosis, replace the valve springs and valve spring retainers using the Repair Procedures below.

MIL "ON" DTC P0300, P0301, P0302, P0303, P0304, P0305, or P0306

Repair Procedure: Disassembly

1. Disconnect the cable from the negative (-) battery terminal.
2. Remove the cool air intake duct seal by removing the 7 clips. **Figure 1.**

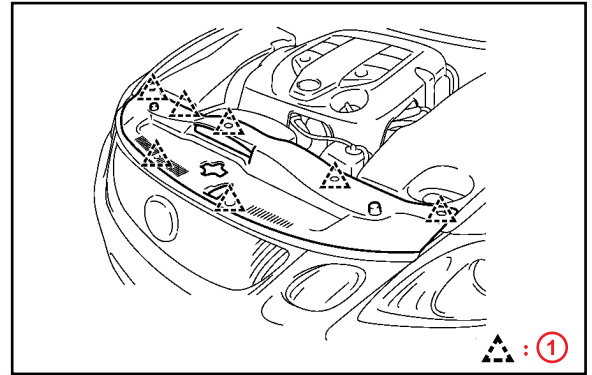

1	Clip
----------	-------------

3. Remove the engine compartment side cover RH by removing the nut and 2 clips.

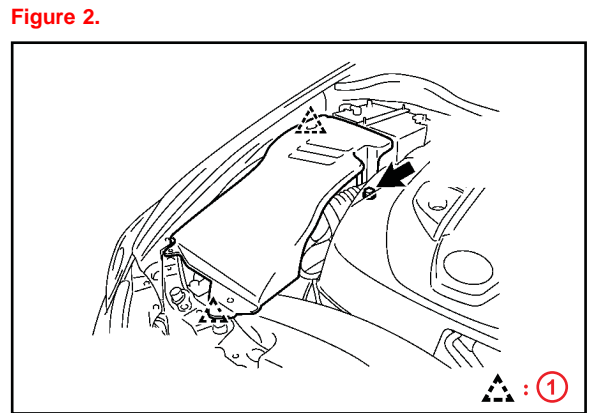

1	Clip
----------	-------------

MIL "ON" DTC P0300, P0301, P0302, P0303, P0304, P0305, or P0306

Repair Procedure: Disassembly (Continued)

4. Remove the engine compartment side cover LH by removing the 3 clips.

Figure 3.

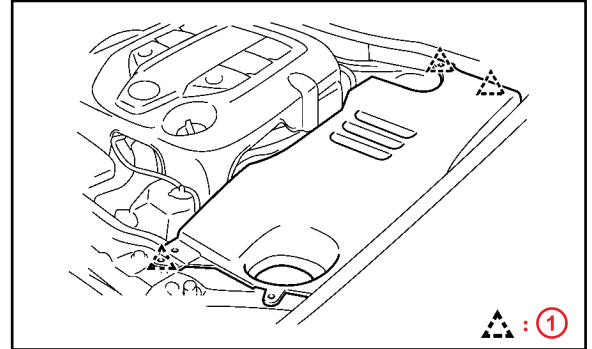

1	Clip
----------	-------------

5. Remove the V-bank cover sub-assembly.
 - A. Raise the V-bank cover to disengage the clip on the rear of the cover.

Figure 4.

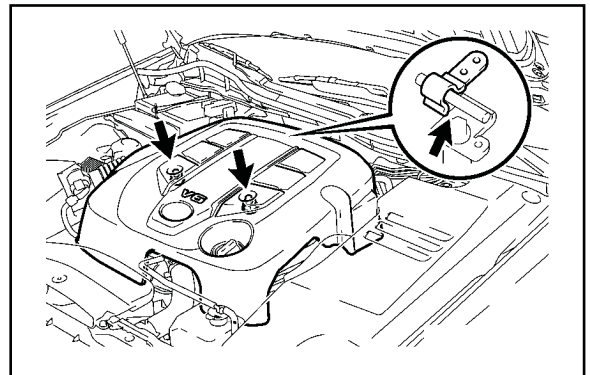

- B. Raise the cover again to remove the 2 nuts on the front of the cover and remove the cover.

NOTE

Attempting to disengage the rear clip and remove the 2 nuts at the same time may cause the cover to break.

MIL "ON" DTC P0300, P0301, P0302, P0303, P0304, P0305, or P0306**Repair Procedure: Disassembly (Continued)**

6. Discharge the fuel system pressure.

FUEL SYSTEM CAUTIONS:

- Do NOT smoke or work near an open flame when working on the fuel system.
- Keep gasoline away from rubber or leather parts.
- Do NOT allow fuel to spray when removing the pipe between the high pressure side fuel pump and the fuel injector. The fuel in the pipe is highly pressurized.
- Wear safety goggles while working with the fuel system under pressure.
- Do NOT disconnect any part of the fuel system until you have discharged the fuel system pressure.
- Even after discharging the fuel pressure, place a shop rag over fittings as you separate them to reduce risk of fuel spray on yourself or in the engine compartment.

A. Disconnect the fuel pump connector.

Figure 5.

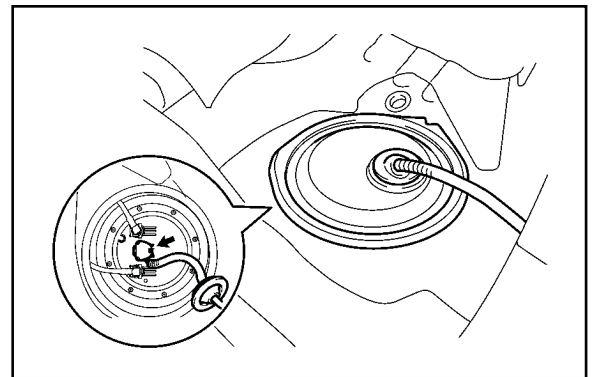

B. Connect the cable to the negative (–) battery terminal.

C. Start the engine. After the engine has stopped on its own, turn the engine switch OFF.

HINT

DTC P0171/P0172 (System Too Lean) may be set.

D. Crank the engine again, and then check that the engine does NOT start.

E. Loosen the fuel tank cap to discharge the pressure in the fuel tank completely.

F. Reconnect the fuel pump connector.

G. Disconnect the cable from the negative (–) battery terminal.

MIL "ON" DTC P0300, P0301, P0302, P0303, P0304, P0305, or P0306

Repair Procedure: Disassembly (Continued)

7. Remove the No. 1 inlet air cleaner by removing the bolt and clip.

Figure 6.

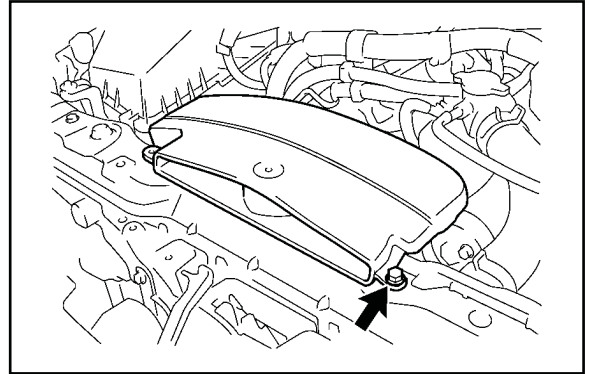

8. Disconnect the ventilation hose from the cylinder head.

Figure 7.

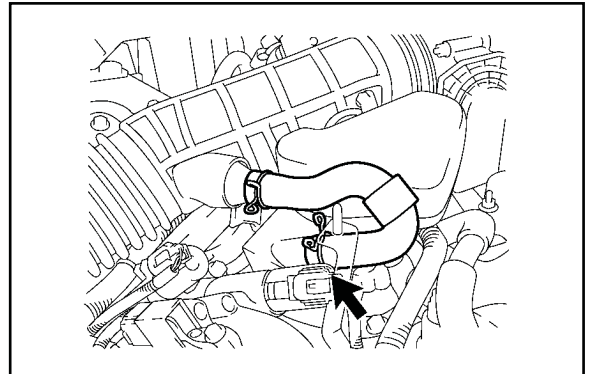

9. Remove the air cleaner cap with air cleaner hose.

Figure 8.

- A. Disconnect the MAF meter connector.
- B. Disconnect the clamp from the air cleaner.
- C. Disconnect the EVAP VSV.

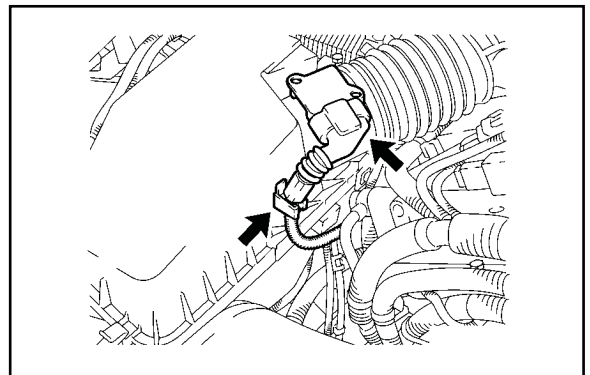

MIL "ON" DTC P0300, P0301, P0302, P0303, P0304, P0305, or P0306

Repair Procedure: Disassembly (Continued)

- D. Loosen the hose clamp and air cleaner cap with air cleaner hose.

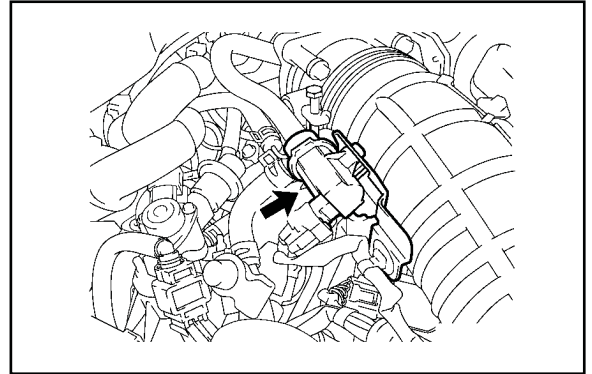
Figure 9.

10. Remove the air cleaner case sub-assembly by removing the 3 bolts.

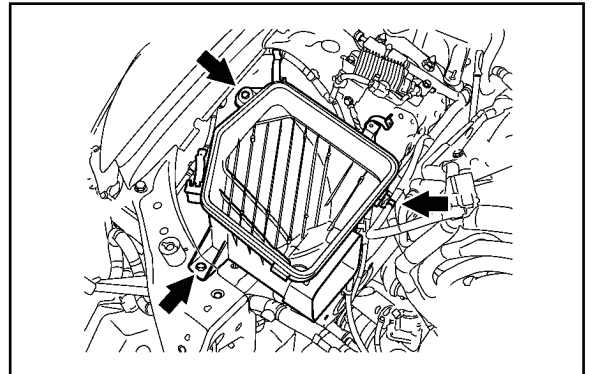
Figure 10.

11. Disconnect the union to check valve hose by removing the clamp.
12. Disconnect the No. 2 fuel vapor feed hose by removing the clamp.

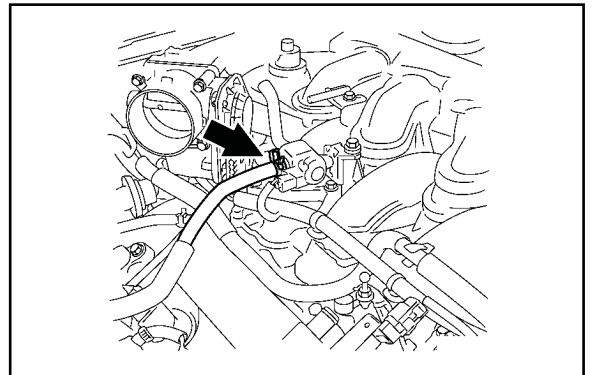
Figure 11.

MIL "ON" DTC P0300, P0301, P0302, P0303, P0304, P0305, or P0306

Repair Procedure: Disassembly (Continued)

13. Disconnect the fuel main tube.

Figure 12.

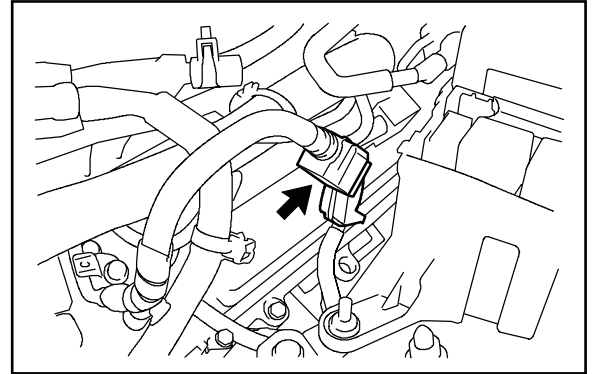

14. Remove the throttle body assembly (with motor).

- A. Disconnect the throttle motor connector.
- B. Remove the 4 bolts and disconnect the throttle body from the intake surge tank.

Figure 13.

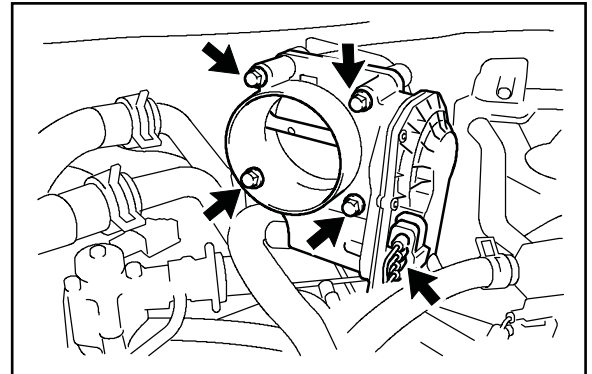

HINT

Do NOT disconnect the water bypass hose.

15. Remove the intake air surge tank assembly.

NOTE

Cover the top surface of the intake manifold with duct tape (or equivalent) to prevent foreign material from falling into the engine.

- A. Disconnect the vacuum hose from the intake air surge tank.

MIL "ON" DTC P0300, P0301, P0302, P0303, P0304, P0305, or P0306

Repair Procedure: Disassembly (Continued)

- B. Remove the bolt and disconnect the No. 1 vacuum switching valve assembly from the intake air surge tank.

Figure 14.

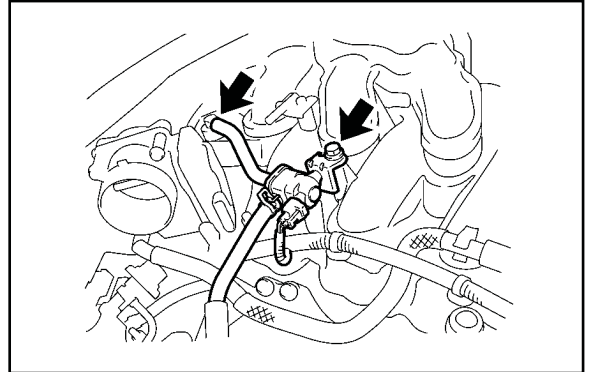

- C. Disconnect the wire harness and hose from the surge tank.

Figure 15.

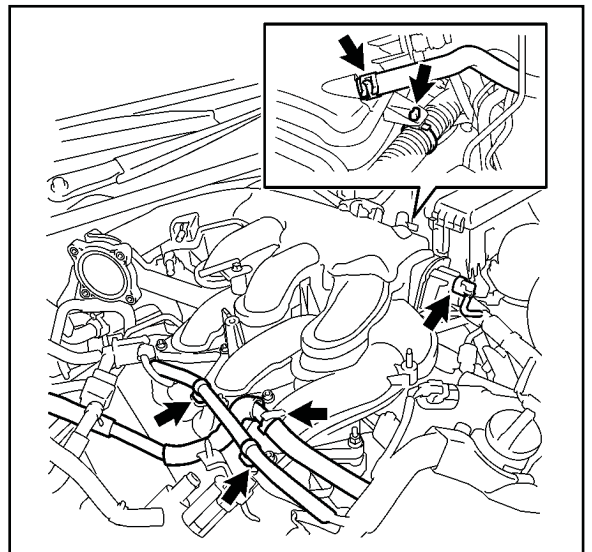

MIL "ON" DTC P0300, P0301, P0302, P0303, P0304, P0305, or P0306

Repair Procedure: Disassembly (Continued)

- D. Disconnect the ventilation hose from the intake air surge tank

Figure 16.

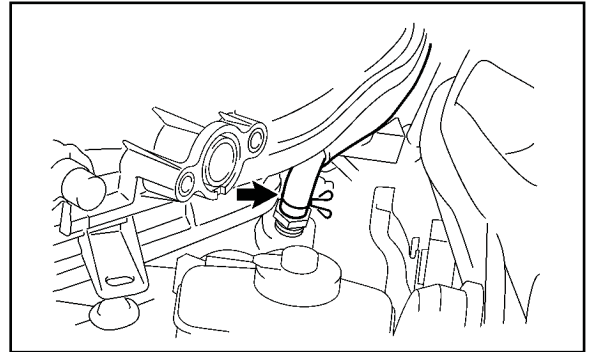

- E. Remove the bolt and water hose joint from the intake air surge tank.

Figure 17.

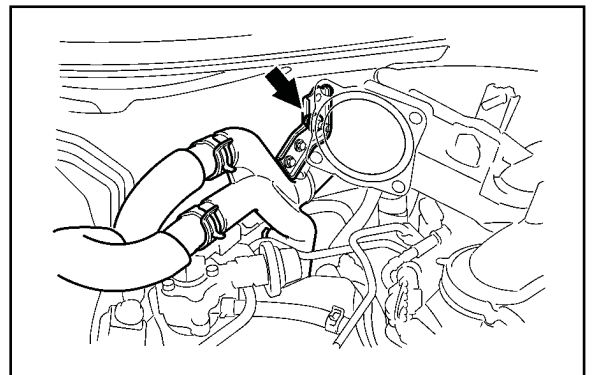

- F. Remove the bolt and disconnect the surge tank stay.

Figure 18.

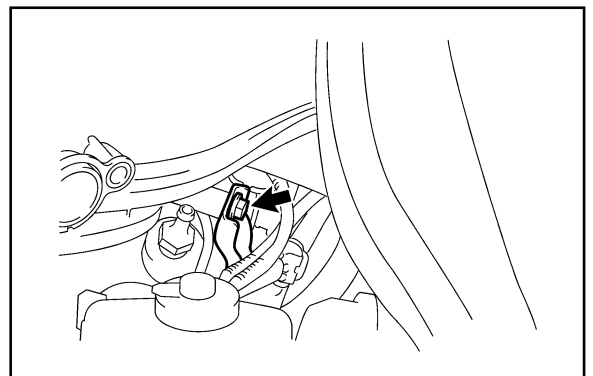

- G. Using a 5-mm hexagon socket wrench, remove the 7 bolts, 2 nuts, and gasket.

MIL "ON" DTC P0300, P0301, P0302, P0303, P0304, P0305, or P0306

Repair Procedure: Disassembly (Continued)

16. Remove fuel pipe No. 1.

A. Disconnect the No. 3 fuel hose from the No. 1 fuel pipe.

Figure 19.

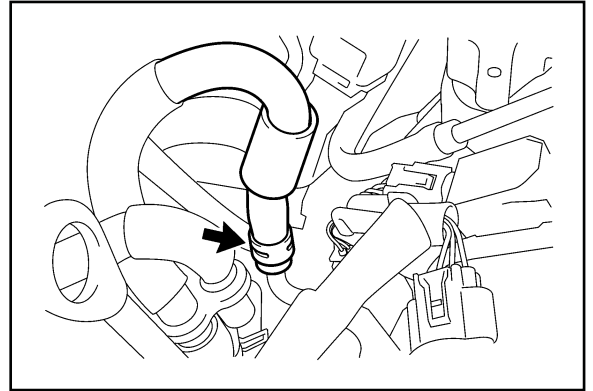

B. Disconnect the 2 fuel hoses.

C. Remove the 2 bolts and No. 1 fuel pipe.

Figure 20.

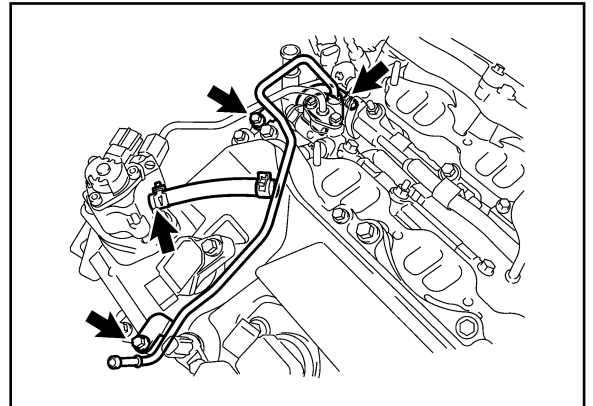

MIL "ON" DTC P0300, P0301, P0302, P0303, P0304, P0305, or P0306

Repair Procedure: Disassembly (Continued)

17. Disconnect the No. 2 fuel pipe.

A. Disconnect the fuel high pressure side fuel pump connector.

B. Secure the union bolt in place on the fuel pump side with a 21-mm wrench. Using a 19-mm union nut wrench, loosen the union and remove the fuel pipe.

Figure 21.

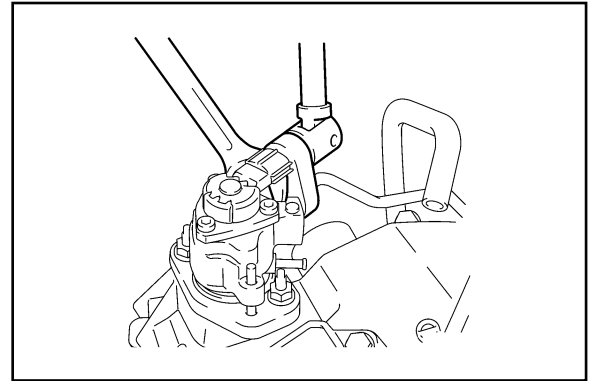

NOTE

- There must be absolutely **NO** free play in the union on the fuel pump side.
- If the union on the fuel pump side has free play, replace the fuel pump.

C. Remove the 2 bolts on the delivery pipe side.

Figure 22.

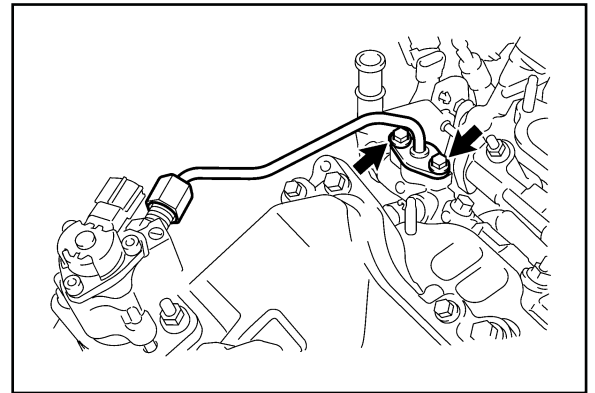

NOTE

- Do **NOT** remove the fuel pipe from the delivery pipe. **ONLY** remove the 2 bolts.
- If the No. 2 fuel pipe *is* accidentally removed, replace its O-ring, No. 1 backup ring, and No. 2 backup ring.

18. Remove the fuel pump assembly.

A. Remove the 2 nuts, 2 stud bolts, and fuel pump.

B. Remove the fuel insulator from the cylinder head cover.

NOTE

- To keep the nipple joint for the fuel pipe free of foreign matter, cover with a plastic bag.
- Remove the engine oil out of the oil pool from the cylinder head cover's fuel pump attachment hole.

MIL "ON" DTC P0300, P0301, P0302, P0303, P0304, P0305, or P0306

Repair Procedure: Disassembly (Continued)

- 19. Remove the ignition coil assemblies.
- 20. Remove the No. 1 oil pipe union bolt from the oil pipe.

Figure 23.

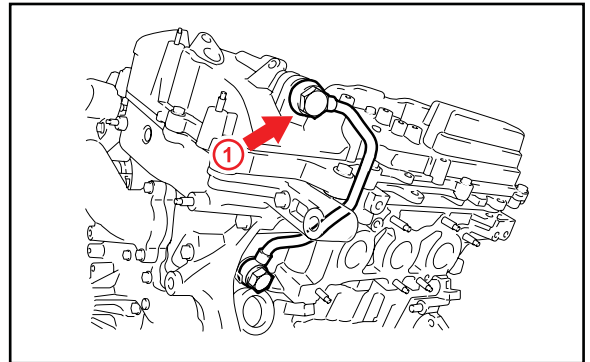

1	Oil Pipe Union
----------	-----------------------

- 21. Remove No. 2 oil pipe union bolt from the oil pipe.

Figure 24.

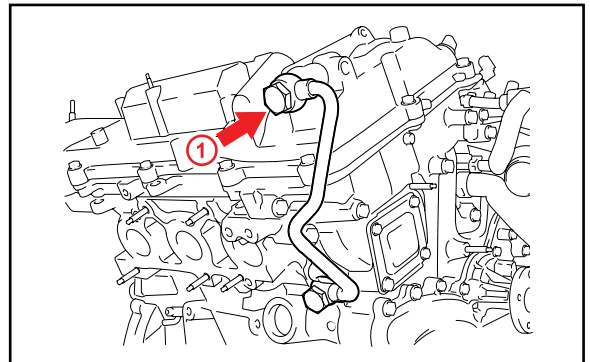

1	Oil Pipe Union
----------	-----------------------

MIL "ON" DTC P0300, P0301, P0302, P0303, P0304, P0305, or P0306

Repair Procedure: Disassembly (Continued)

22. Remove the cylinder head cover LH.

A. Remove the 12 bolts, oil seal washer, and cylinder head cover.

NOTE

- Cover the hole around the timing chain with shop rags to prevent foreign material from falling into the engine.
- The baffle plate is located on the back of the portion shown in the illustration.
- Do NOT damage the baffle plate when removing the cylinder head cover.

Figure 25.

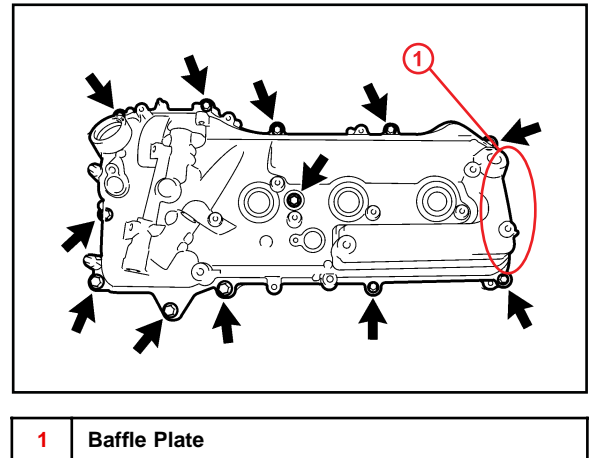

B. Remove the cylinder head cover gasket from the cylinder head cover.

C. Remove the 3 gaskets.

Figure 26.

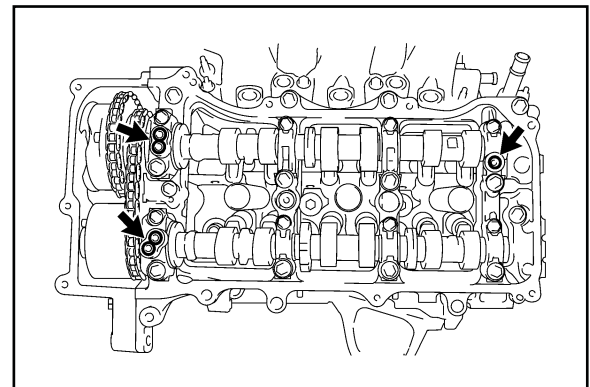

23. Remove the cylinder head cover RH.

A. Remove the 12 bolts, 2 oil seal washers, and cylinder head cover.

NOTE

- Cover the hole around the timing chain with shop rags to prevent foreign material from falling into the engine.
- The baffle plate is located on the back of the portion shown in the illustration.
- Do NOT damage the baffle plate when removing the cylinder head cover.

Figure 27.

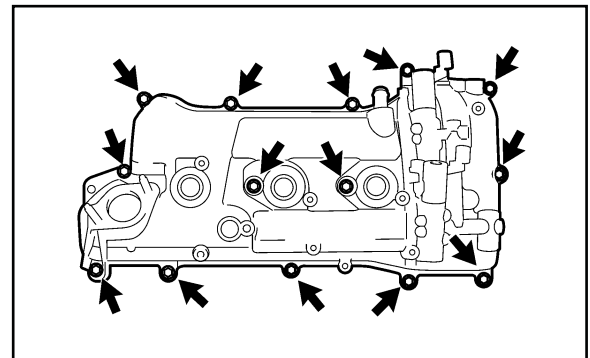

MIL "ON" DTC P0300, P0301, P0302, P0303, P0304, P0305, or P0306

Repair Procedure: Disassembly (Continued)

- B. Remove the cylinder head cover gasket from the cylinder head cover.
- C. Remove the 3 gaskets.

Figure 28.

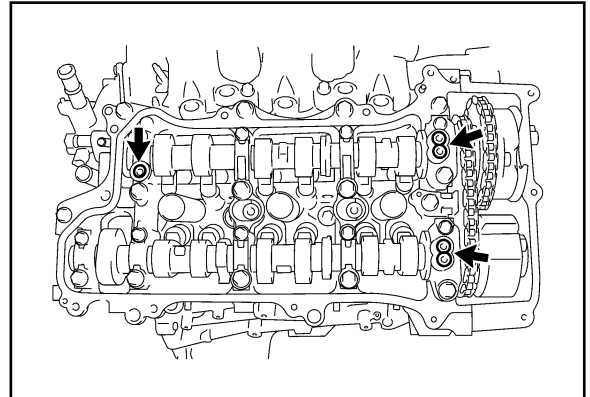

- 24. Remove engine cover No. 1 by removing the 3 clips.

Figure 29.

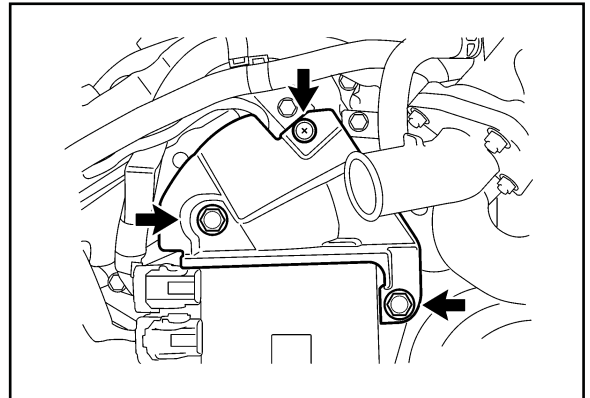

- 25. Remove the injector driver by removing the bolt and 2 nuts.

Figure 30.

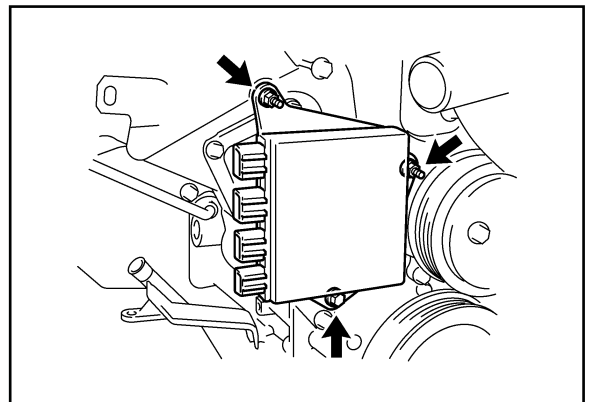

MIL "ON" DTC P0300, P0301, P0302, P0303, P0304, P0305, or P0306

Repair Procedure: Disassembly (Continued)

26. Remove the timing chain cover plate by removing the 4 bolts, timing chain cover plate, and timing chain cover plate gasket.

Figure 31.

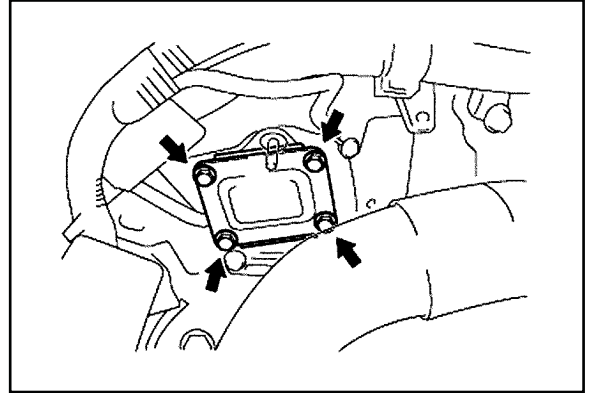

MIL "ON" DTC P0300, P0301, P0302, P0303, P0304, P0305, or P0306

Repair Procedure: Disassembly (Continued)

27. Set the No. 1 cylinder to TDC/compression.

- A. Set the timing mark to 0° on the timing chain cover by rotating the crankshaft clockwise.
- B. Check that the timing marks of the camshaft timing gear assembly are aligned with the timing marks of the camshaft bearing cap.

HINT
If the timing marks are NOT aligned, turn the crankshaft one revolution (360°) clockwise and align the timing marks.

C. Using a paint marker, mark the sprocket wheel, timing mark of the camshaft timing gear assembly, and the timing chain itself.

HINT
Wipe any oil off before marking.

Figure 32.

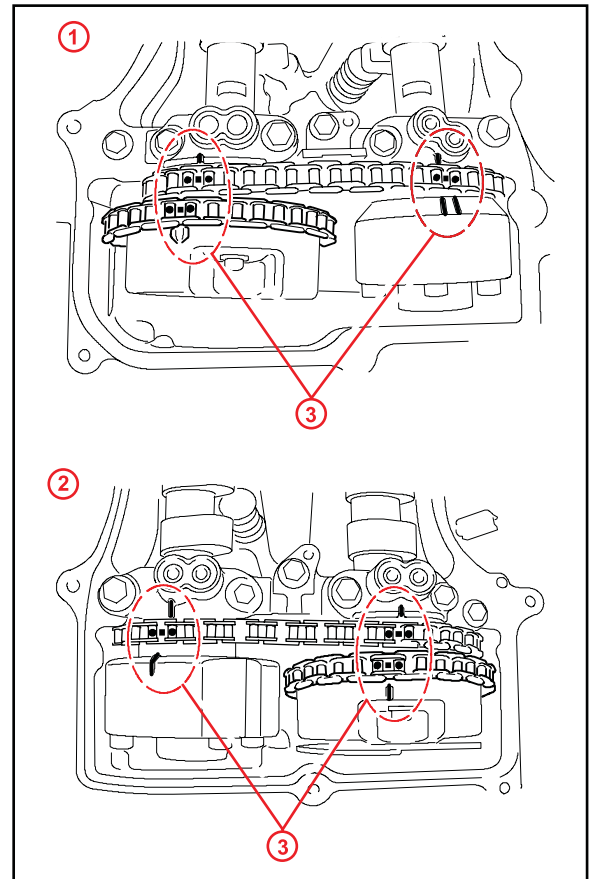

1	LH Bank Side
2	RH Bank Side
3	Paint Marks

MIL "ON" DTC P0300, P0301, P0302, P0303, P0304, P0305, or P0306

Repair Procedure: Disassembly (Continued)

28. Remove the chain tensioner assembly No. 1.

A. Loosen tension from the timing chain by rotating the crankshaft 30° counterclockwise.

HINT

The procedure above is to prevent the valve and piston from hitting each other when turning the crankshaft.

B. Remove the 2 bolts and No. 1 chain tensioner assembly.

Figure 33.

HINT

Do NOT drop the No. 1 chain tensioner assembly and bolts inside the timing chain cover.

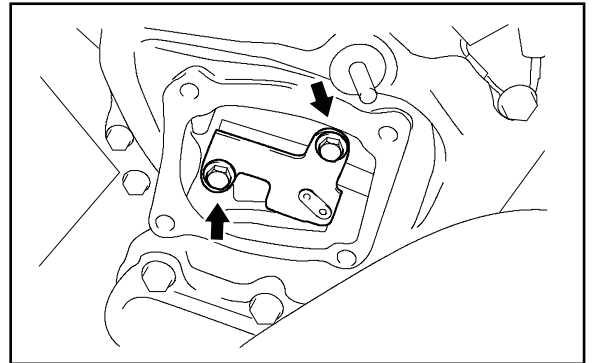

29. Remove the timing chain.

A. LH bank:

(1) Loosen tension from the timing chain by rotating the crankshaft.

HINT

Oil may spray out of the holes on top of the No. 3 camshaft bearing cap when rotating the crankshaft. Use shop rags to prevent any spray.

(2) Remove the timing chain from the timing gear and rest it on the camshaft timing gear assembly temporarily.

B. RH bank:

(1) Loosen tension from the timing chain by rotating the crankshaft.

NOTE

Oil may spray out of the holes on top of the No. 1 camshaft bearing cap when rotating the crankshaft. Use shop rags to prevent any spray.

MIL "ON" DTC P0300, P0301, P0302, P0303, P0304, P0305, or P0306

Repair Procedure: Disassembly (Continued)

- (2) Rotate the crankshaft clockwise until the flat surface of the timing exhaust gear assembly faces the vertical position.
 - (3) Remove the timing chain from the timing gear and rest it on the camshaft timing gear assembly temporarily.
30. Remove the camshaft bearing cap.

A. RH bank:

- (1) Check that the camshafts are in the neutral position shown in the illustration.

Figure 34.

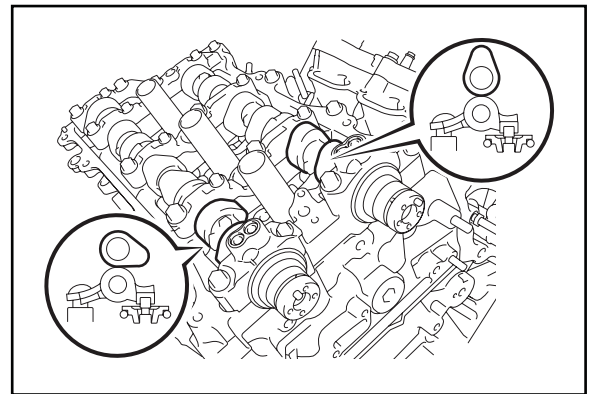

- (2) Uniformly loosen and remove the 9 camshaft bearing cap M6 bolts in the sequence shown in the illustration.

Figure 35. M6 Loosening Sequence

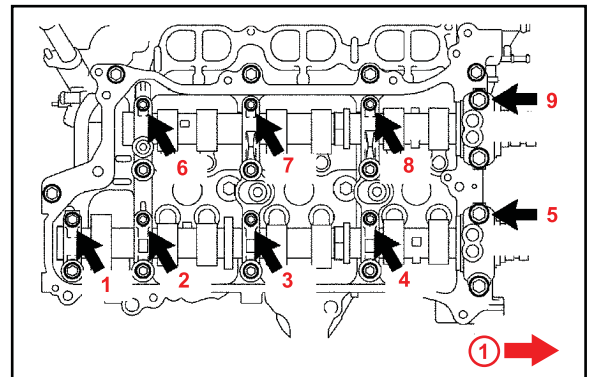

HINT
Keep the camshaft horizontal while loosening the bearing cap bolts.

1 Front

MIL "ON" DTC P0300, P0301, P0302, P0303, P0304, P0305, or P0306

Repair Procedure: Disassembly (Continued)

- (3) Uniformly loosen and remove the 9 camshaft bearing cap M8 bolts in the sequence shown in the illustration.

Figure 36. M8 Loosening Sequence

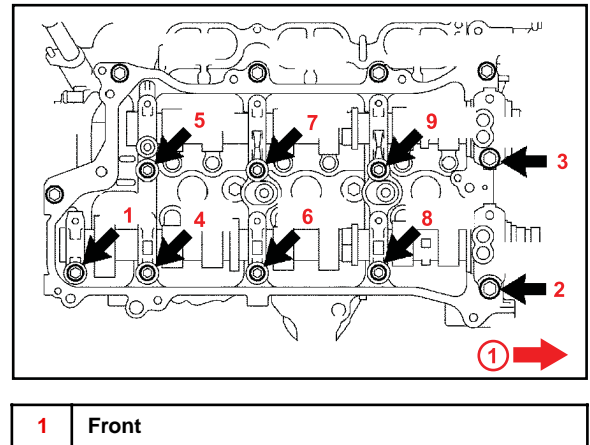

- (4) Remove the 6 camshaft bearing caps.

B. LH bank:

- (1) Check that the camshafts are in the neutral position shown in the illustration.

Figure 37.

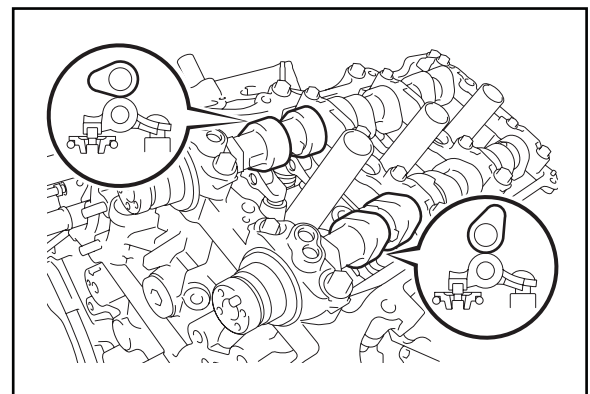

MIL "ON" DTC P0300, P0301, P0302, P0303, P0304, P0305, or P0306

Repair Procedure: Disassembly (Continued)

- (2) Uniformly loosen and remove the 8 camshaft bearing cap M6 bolts in the sequence shown in the illustration.

HINT
Keep the camshaft horizontal while loosening the bearing cap bolts.

Figure 38. M6 Loosening Sequence

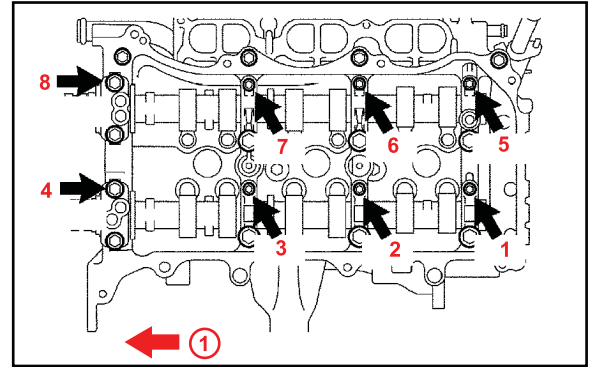

1 Front

- (3) Uniformly loosen and remove the 8 camshaft bearing cap M8 bolts in the sequence shown in the illustration.

Figure 39. M8 Loosening Sequence

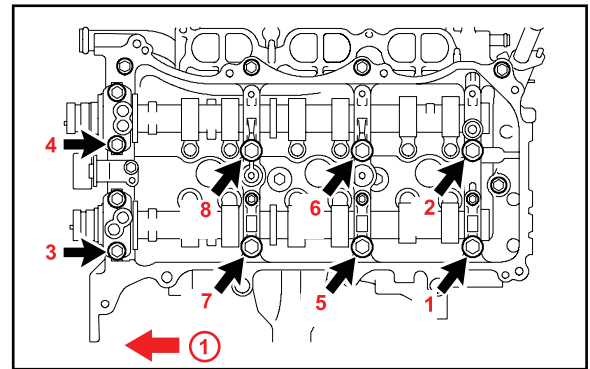

1 Front

- (4) Remove the 5 camshaft bearing caps.

MIL "ON" DTC P0300, P0301, P0302, P0303, P0304, P0305, or P0306

Repair Procedure: Disassembly (Continued)

31. Remove the No. 2 camshaft.

- A. Remove the bolt for the No. 2 chain tensioner assembly.

Figure 40.

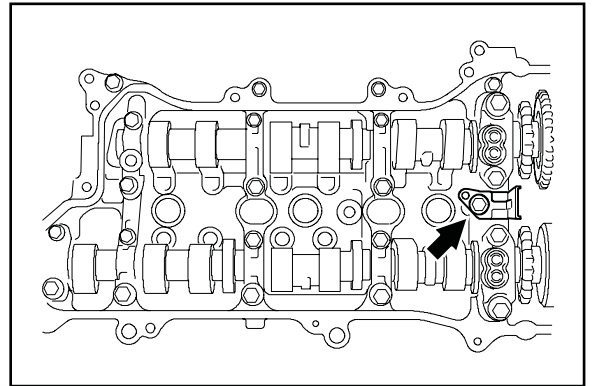

- B. While holding No. 2 camshaft, remove the No. 2 chain tensioner assembly.

- C. While holding the No. 2 chain, slide the No. 2 camshaft out toward the front of the vehicle.

Figure 41.

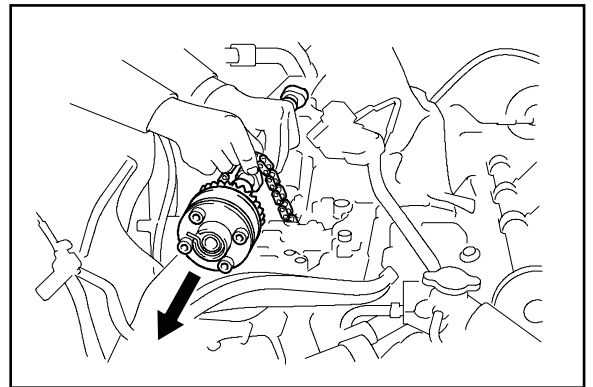

32. Remove the No. 1 camshaft.

- A. Hold the rear portion of the No. 1 camshaft (with tilt position).
- B. Hold the timing chain from the timing gear, and slide the No. 1 camshaft (with No. 2 chain) out toward the rear of the vehicle.

NOTE

Keep tension on the timing chain to avoid separation from the crankshaft timing gear.

MIL "ON" DTC P0300, P0301, P0302, P0303, P0304, P0305, or P0306**Repair Procedure: Disassembly (Continued)**

- C. Tie the timing chain to the oil pipe with a strap. **Figure 42.**

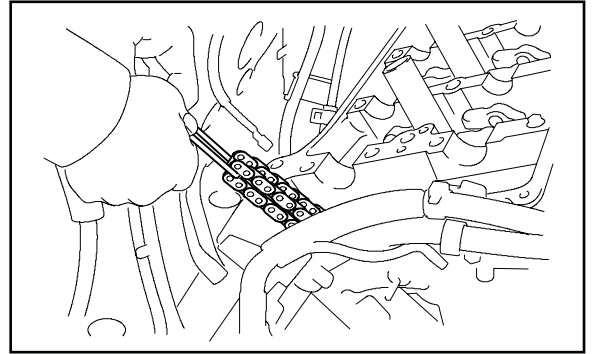

33. Remove camshaft No. 4.
- A. Remove the bolt for the No. 3 chain tensioner assembly.
 - B. While holding the No. 4 camshaft, remove the No. 3 chain tensioner assembly.
 - C. Hold the No. 2 chain, and slide the No. 4 camshaft out toward the front of the vehicle.
34. Remove camshaft No. 3.

- A. Hold the rear portion of the No. 3 camshaft (with tilt position).
- B. Remove the timing chain from the timing gear, and slide the No. 3 camshaft (with the No. 2 chain) out toward the rear of the vehicle.

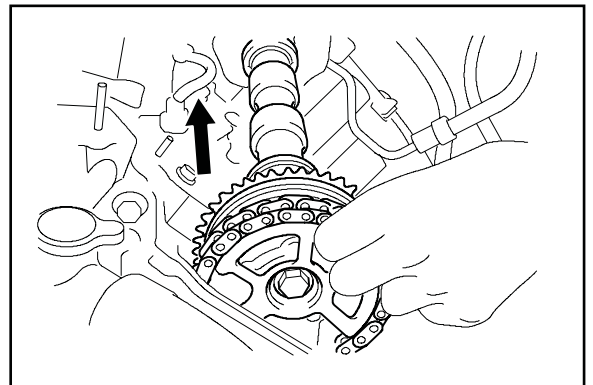
Figure 43.**NOTE**

Keep tension on the timing chain to avoid separation from the crankshaft timing gear.

- C. Tie the timing chain to the oil pipe with a strap.

MIL "ON" DTC P0300, P0301, P0302, P0303, P0304, P0305, or P0306

Repair Procedure: Disassembly (Continued)

35. Remove the valve rocker arms for all cylinders.

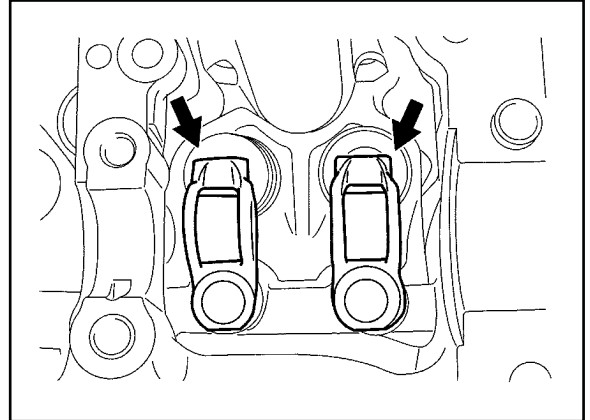
Figure 44.

36. Remove the valve stem cap.
37. Attach the anti-rotation tool to the crankshaft.

Figure 45.**NOTE**

Make sure that the anti-rotation tool is secured to prevent the crankshaft from turning either clockwise or counterclockwise.

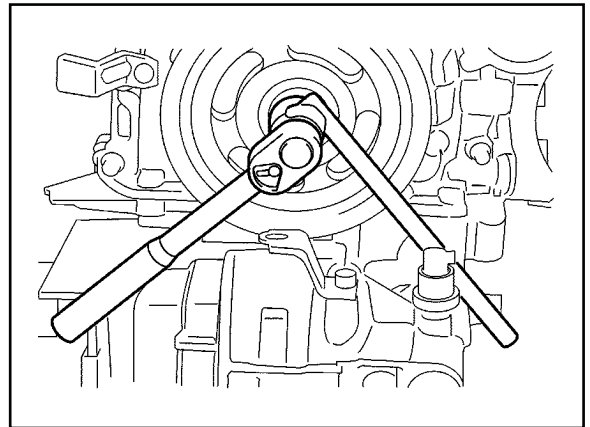

38. Remove the spark plugs.

MIL "ON" DTC P0300, P0301, P0302, P0303, P0304, P0305, or P0306

Repair Procedure: Disassembly (Continued)

39. Attach the air lead pipe, or equivalent tool, to allow compressed air to be applied to the combustion chamber.

Torque: 10 N*m (102 kgf*cm, 7 ft*lbf)

Figure 46.

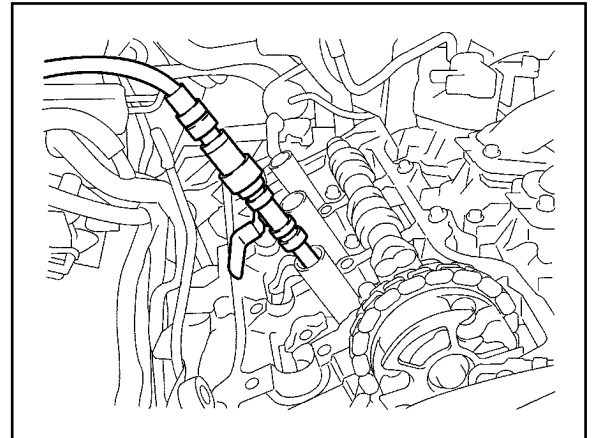

40. Pressurize the combustion chamber.

Slowly apply air pressure into the combustion chamber.

Recommended air pressure: 58 – 116 psi (4.1 – 8.2 kgf/cm², 400 – 700 kPa)

NOTE

- Pressurize the combustion chamber slowly to prevent unexpected crankshaft rotation.
- Make sure that the anti-rotation tool is attached properly before putting air into the combustion chamber.

41. Remove the valve spring retainer lock using a valve spring removal tool or equivalent tool.

NOTE

- Be careful as the valve spring may pop out when the valve spring retainer lock is disassembled.
- Cover the oil holes on the cylinder head with shop rags to prevent the valve spring retainer lock from falling into the engine.

Figure 47.

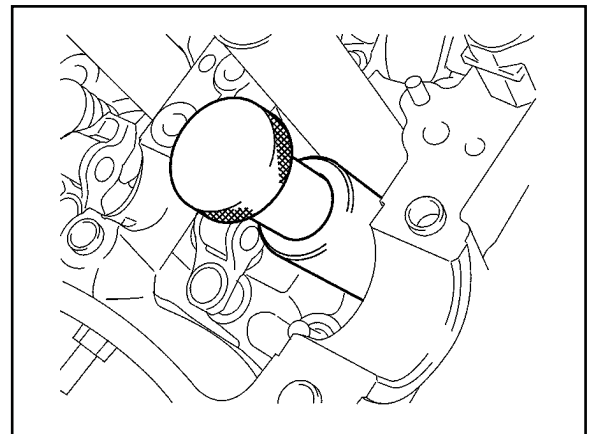

42. Remove the valve spring retainer.

43. Remove the valve spring.

MIL "ON" DTC P0300, P0301, P0302, P0303, P0304, P0305, or P0306

Repair Procedure: Disassembly (Continued)

44. Install the NEW valve spring.
45. Install the NEW valve spring retainer.
46. Install the valve spring retainer locks.
 - A. Using the valve spring installation tool or equivalent tool, install the valve spring retainer lock.

NOTE

- The valve spring may pop out if the valve spring retainer locks are NOT installed properly.
- Cover the oil holes on the cylinder head with shop rags to prevent the valve spring retainer locks from falling into the engine.

HINT

Applying grease to the valve spring retainer locks may assist in holding them together.

- B. Using a plastic hammer, tap the valve spring retainer to check that the valve spring retainer lock fits properly.
47. Release the air inside the combustion chamber.
48. Remove the air lead pipe or equivalent tool.
49. Proceed to replace the remaining 23 valve springs and valve spring retainers following steps 40 – 48 above.

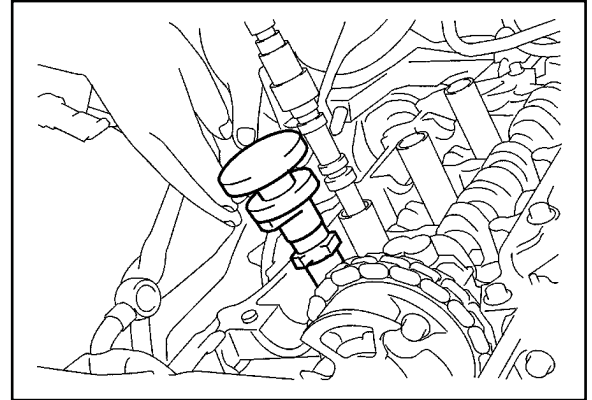
Figure 48.

MIL "ON" DTC P0300, P0301, P0302, P0303, P0304, P0305, or P0306

Repair Procedure: Disassembly (Continued)

50. Remove the anti-rotation tool from the crankshaft. **Figure 49.**

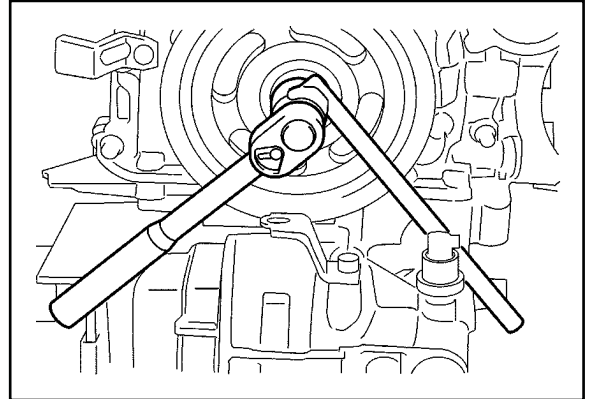

51. Install the spark plugs.
Torque: 25 N*m (255 kgf*cm, 18 ft*lbf)
52. Install the valve stem caps.
53. Install the valve rocker arms.

Figure 50.

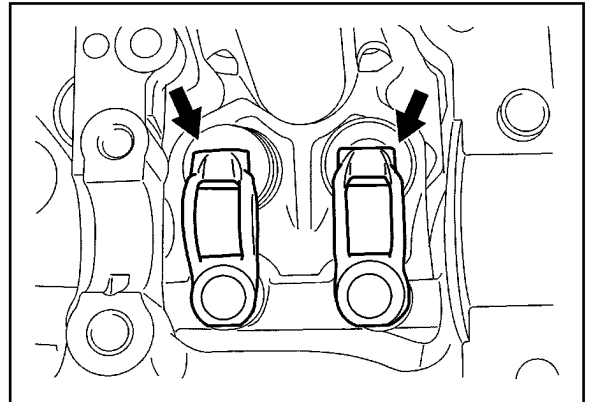

MIL "ON" DTC P0300, P0301, P0302, P0303, P0304, P0305, or P0306

Repair Procedure: Reassembly

1. Install the No. 3 camshaft.
 - A. Align the mark plate (yellow) of the No. 2 chain with the timing marks of the camshaft timing gear assembly shown in the illustration.
 - B. Clean the camshaft journals and apply engine oil.

Figure 51.

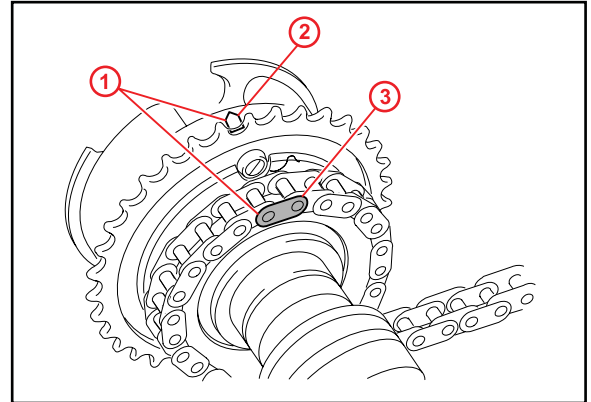

1	Align
2	Timing Mark
3	Mark Plate (Yellow)

- C. Make sure that the valve rocker arms are installed with the lash adjuster and valve stem cap properly as shown in the illustration.

Figure 52.

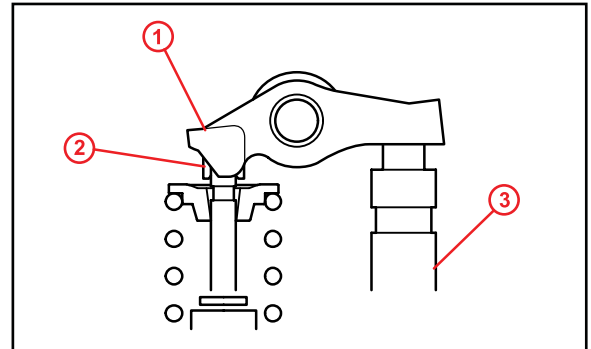

1	Valve Rocker Arm
2	Valve Stem Cap
3	Valve Lash Adjuster

MIL "ON" DTC P0300, P0301, P0302, P0303, P0304, P0305, or P0306

Repair Procedure: Reassembly (Continued)

- D. Temporarily put the timing chain to the No. 3 camshaft on the camshaft timing gear assembly and place the No. 3 camshaft on the camshaft housing LH.

NOTE

- Temporarily put the timing chain on the camshaft timing gear assembly without installing to the sprocket.
- Place the camshaft as the timing mark faces on the top.

Figure 53.

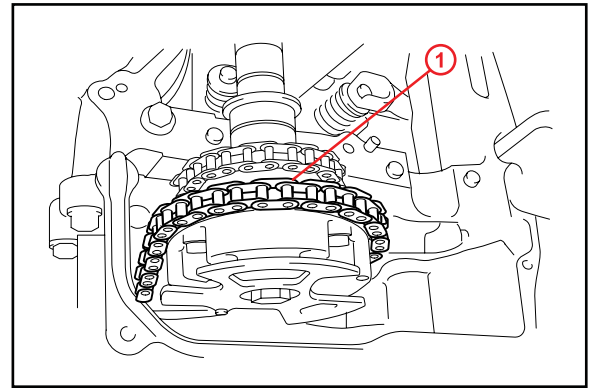

1	Put Chain on Timing Gear
----------	---------------------------------

- 2. Install the No. 1 camshaft using the same procedure as step 1.
- 3. Install the No. 4 camshaft.
 - A. Clean the camshaft journals and apply engine oil to them.
 - B. Hold the No. 2 chain and slide the No. 4 camshaft in from the front of the vehicle.
- C. Align the mark plate (yellow) with the timing marks of the camshaft timing exhaust gear LH.

Figure 54.

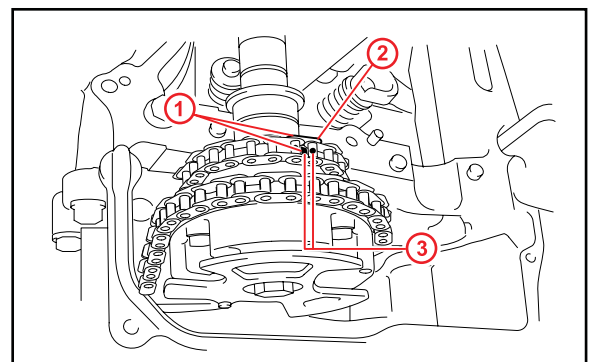

1	Align Marks
2	Mark Plate
3	Paint Marks

MIL "ON" DTC P0300, P0301, P0302, P0303, P0304, P0305, or P0306**Repair Procedure: Reassembly (Continued)**

- D. Hold the No. 2 chain and install the No. 3 chain tensioner assembly.

Torque: 21 N*m (214 kgf*cm, 15 ft*lbf)

Figure 55.

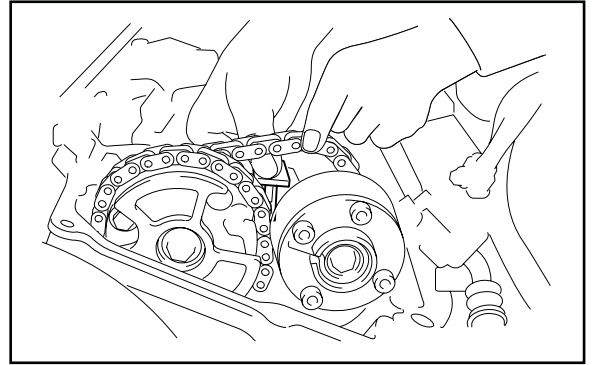

4. Install the No. 2 camshaft using the same procedure as step 3.

5. Install the camshaft bearing cap.

A. LH bank:

- (1) Clean the camshaft bearing caps and apply engine oil.
- (2) Make sure that the valve rocker arms are properly installed with each lash adjuster and valve stem cap.
- (3) Make sure of the marks and numbers on the camshaft bearing caps and temporarily tighten the 16 bolts.

Figure 56.

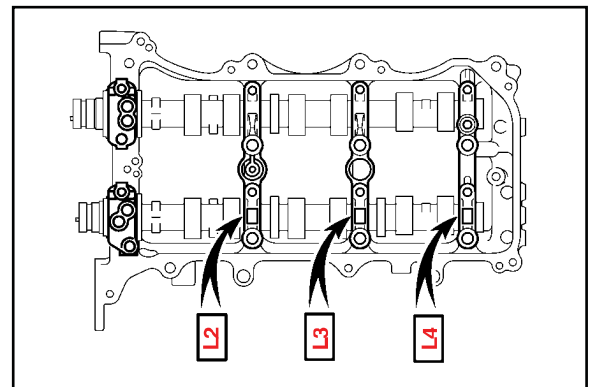

MIL "ON" DTC P0300, P0301, P0302, P0303, P0304, P0305, or P0306

Repair Procedure: Reassembly (Continued)

- (4) Tighten the 8 M6 bolts in the sequence shown.
Torque: 10 N*m (102 kgf*cm, 7 ft*lbf)

Figure 57. M6 Torque Sequence

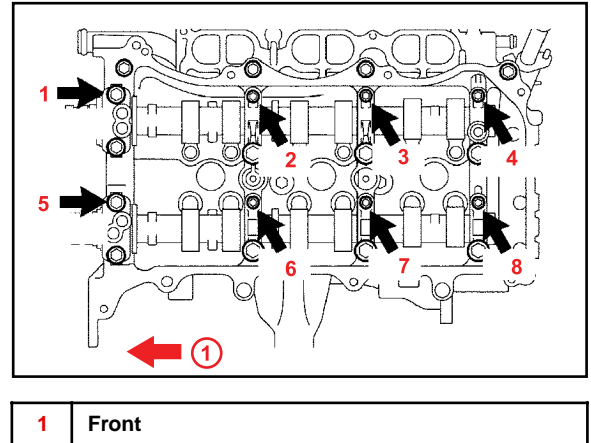

- (5) Tighten the 8 M8 bolts in the sequence shown.
Torque: 28 N*m (286 kgf*cm, 21 ft*lbf)

Figure 58. M8 Torque Sequence

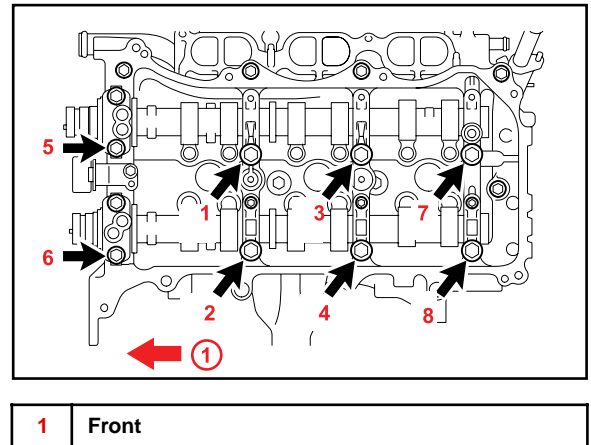

- (6) Tighten the 8 M6 bolts to their final torque value in the sequence shown in Figure 60.
Torque: 16 N*m (163 kgf*cm, 12 ft*lbf)

MIL "ON" DTC P0300, P0301, P0302, P0303, P0304, P0305, or P0306

Repair Procedure: Reassembly (Continued)

B. RH bank:

- (1) Clean the camshaft bearing caps and apply engine oil.
- (2) Make sure that the valve rocker arms are properly installed with each lash adjuster and valve stem cap.
- (3) Make sure of the marks and numbers on the camshaft bearing caps and temporarily tighten the 16 bolts.

Figure 59.

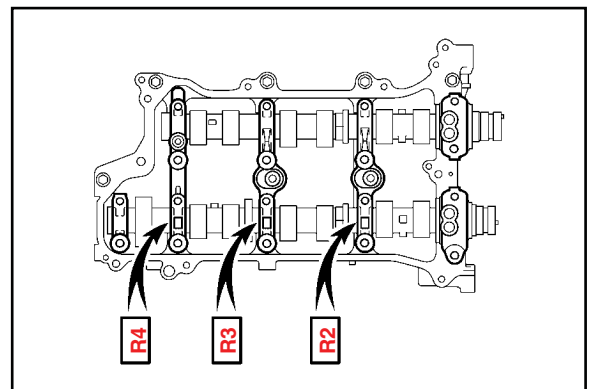

- (4) Tighten the 9 M6 bolts in the sequence shown in the illustration.

Torque: 10 N*m (102 kgf*cm, 7 ft*lbf)

Figure 60. M6 Torque Sequence

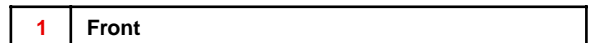
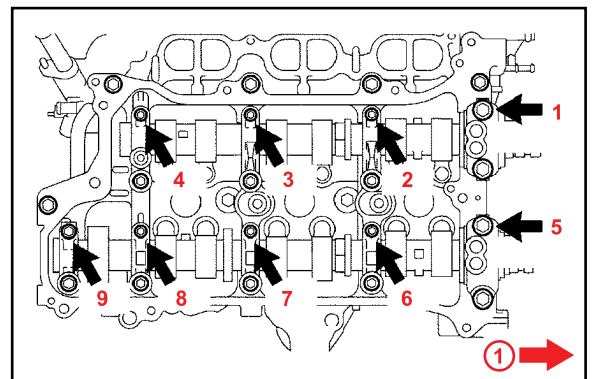

MIL "ON" DTC P0300, P0301, P0302, P0303, P0304, P0305, or P0306

Repair Procedure: Reassembly (Continued)

- (5) Tighten the 9 M8 bolts in the sequence shown in the illustration.
Torque: 28 N*m (286 kgf*cm, 21 ft*lbf)

Figure 61. M8 Torque Sequence

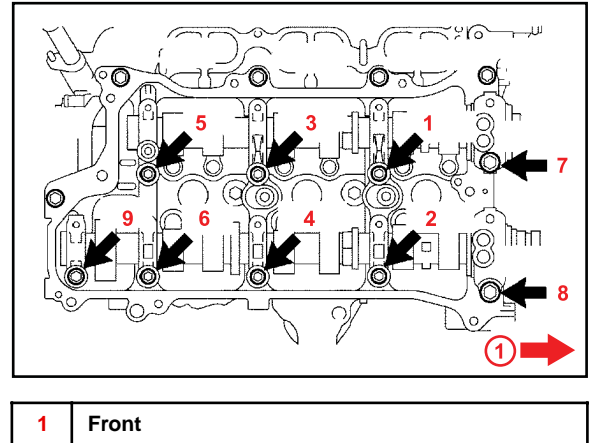

- (6) Tighten the 9 M6 bolts to their final torque value in the sequence shown in the illustration.
Torque: 16 N*m (163 kgf*cm, 12 ft*lbf)

MIL "ON" DTC P0300, P0301, P0302, P0303, P0304, P0305, or P0306

Repair Procedure: Reassembly (Continued)

6. Install the timing chain.

A. LH bank:

Align the mark plate (yellow) of the timing chain with the timing marks of the camshaft timing gear assembly and install to the sprocket.

NOTE

If the paint mark is NOT aligned, turn the crankshaft slightly to adjust the position.

B. RH Bank:

- (1) Align the mark plate (yellow) of the timing chain with the timing marks of the camshaft timing gear assembly and install to the sprocket.

NOTE

If the paint mark is NOT aligned, turn the crankshaft and adjust one notch each as shown in the illustration.

Figure 62.

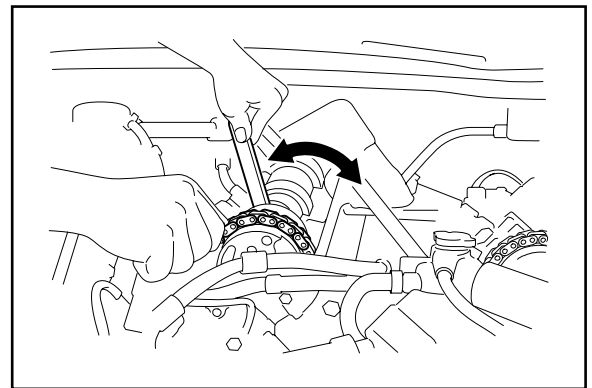

- (2) Set the No. 1 cylinder to TDC/compression, by aligning the timing mark to 0° on the timing chain cover by rotating the crankshaft counterclockwise.
- (3) Slightly turn the crankshaft and loosen tension for the timing chain where the No. 1 chain tensioner is attached.

MIL "ON" DTC P0300, P0301, P0302, P0303, P0304, P0305, or P0306

Repair Procedure: Reassembly (Continued)

- 7. Install the No. 1 chain tensioner assembly.
 - A. Move the stopper plate upward to release the lock, and push the plunger deep into the tensioner.

Figure 63.

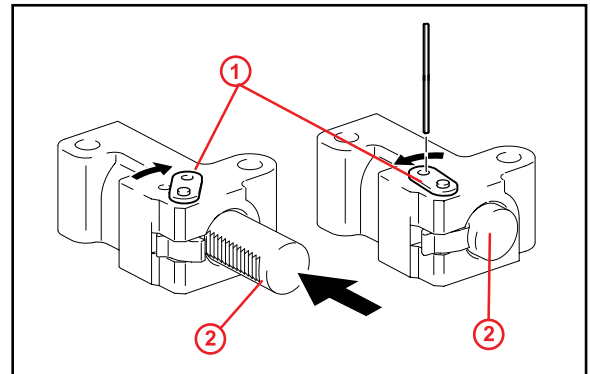

1	Stopper Plate
2	Plunger

- B. Move the stopper plate downward to set the lock, and insert a hexagon wrench into the hole of the stopper plate.
- C. Install the No. 1 chain tensioner assembly with the 2 bolts.

Torque: 10 N*m (102 kgf*cm, 7 ft*lbf)

Figure 64.

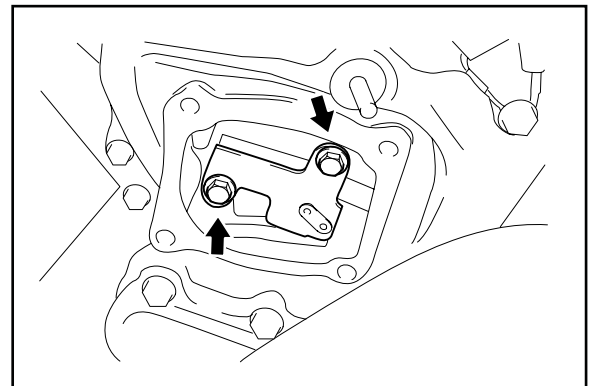

MIL "ON" DTC P0300, P0301, P0302, P0303, P0304, P0305, or P0306

Repair Procedure: Reassembly (Continued)

- D. Remove the lock pin of the No. 1 chain tensioner assembly. Check that each timing mark is aligned with the crankshaft at the TDC/compression.

Figure 65.

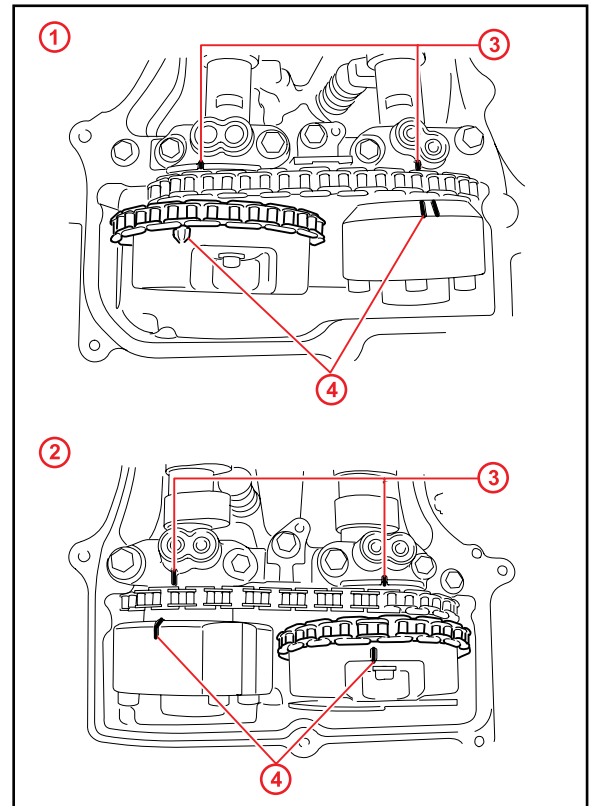

1	LH Bank Side
2	RH Bank Side
3	Timing Marks
4	Paint Marks

- E. Turn the crankshaft 2 rotations and double-check that each timing mark is positioned properly.

MIL "ON" DTC P0300, P0301, P0302, P0303, P0304, P0305, or P0306**Repair Procedure: Reassembly (Continued)**

8. Install the NEW gasket and the timing chain cover plate with the 4 bolts. **Figure 66.**

Torque: 9 N*m (93 kgf*cm, 7 ft*lbf)

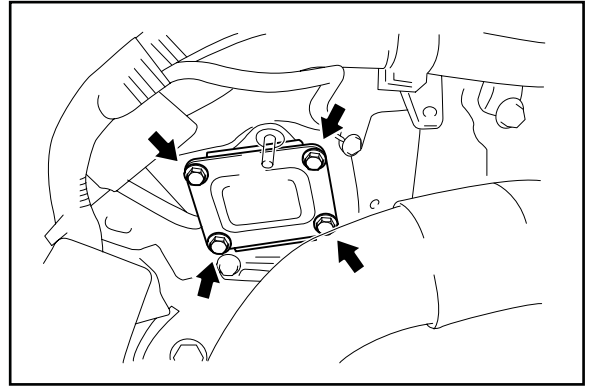

9. Install the injector driver with the bolt and 2 nuts. **Figure 67.**

Torque: 10 N*m (102 kgf*cm, 7 ft*lbf)

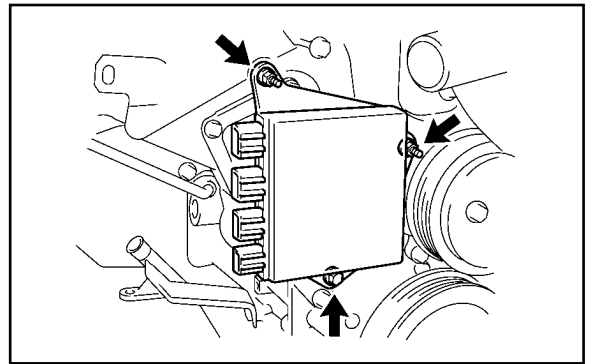

10. Install the No. 1 engine cover with the 3 clips. **Figure 68.**

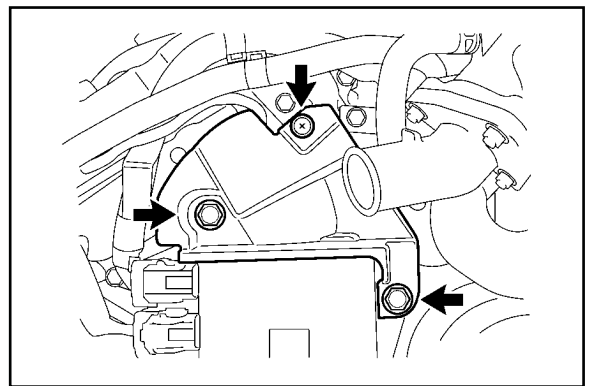

MIL "ON" DTC P0300, P0301, P0302, P0303, P0304, P0305, or P0306

Repair Procedure: Reassembly (Continued)

11. Install the cylinder head cover RH.

A. Apply FIPG sealant as shown in the illustration.

Figure 69.

FIPG sealant: P/N 08826-00080 (or equivalent)

NOTE

- Remove any oil from the contact surface.
- Install the head cover within 3 minutes after applying the FIPG sealant.
- Do NOT start the engine for at LEAST 2 hours after installing.

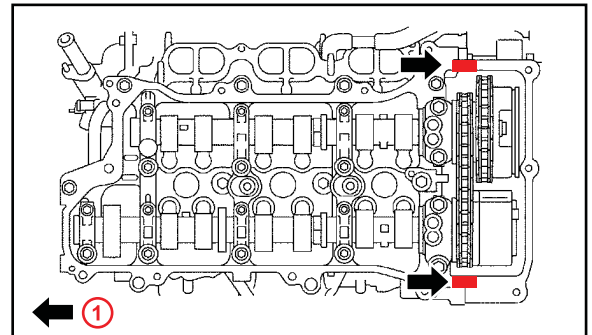

1 FIPG Sealant

B. Install 3 NEW gaskets as shown in the illustration.

Figure 70.

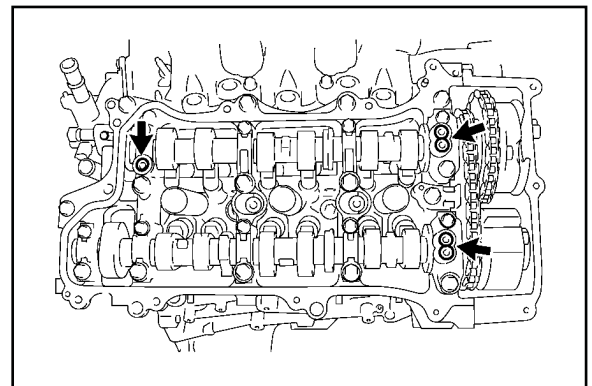

C. Install a NEW gasket to the head cover.

D. Install the head cover with the 14 bolts.

Figure 71.

- Torque:
 Bolts A:
 21 N*m (214 kgf*cm, 15 ft*lbf)
- Torque:
 Bolts except A:
 10 N*m (102 kgf*cm, 7 ft*lbf)

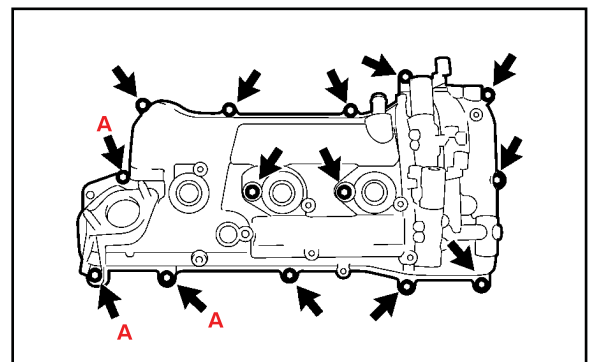

MIL "ON" DTC P0300, P0301, P0302, P0303, P0304, P0305, or P0306

Repair Procedure: Reassembly (Continued)

12. Install the cylinder head cover LH.

A. Apply FIPG sealant as shown in the illustration.

Figure 72.

FIPG sealant: P/N 08826-00080 (or equivalent)

NOTE

- Remove any oil from the contact surface.
- Install the head cover within 3 minutes after applying the FIPG sealant.
- Do NOT start the engine for at LEAST 2 hours after installing.

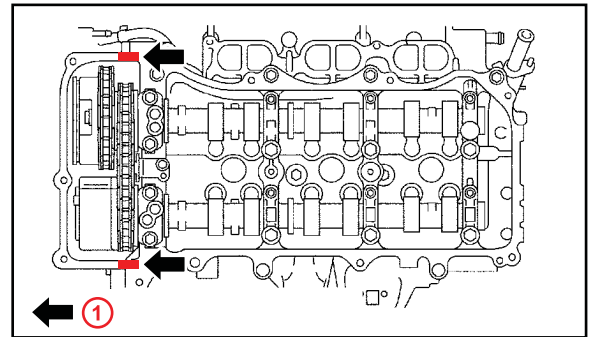

1 FIPG Sealant

B. Install 3 NEW gaskets as shown in the illustration.

Figure 73.

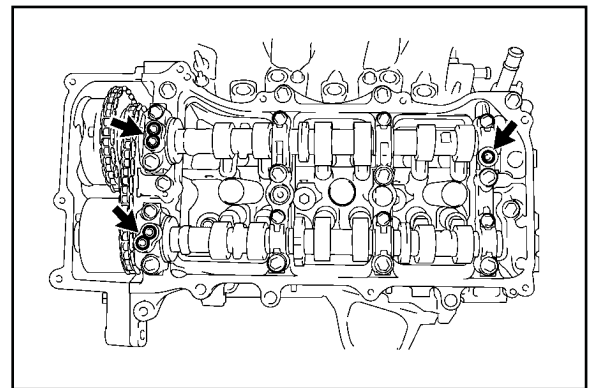

C. Install a NEW gasket to the head cover.

D. Install the head cover with the 12 bolts.

Figure 74.

- Torque:
 Bolts A:
 21 N*m (214 kgf*cm, 15 ft*lbf)
- Torque:
 Bolts except A:
 10 N*m (102 kgf*cm, 7 ft*lbf)

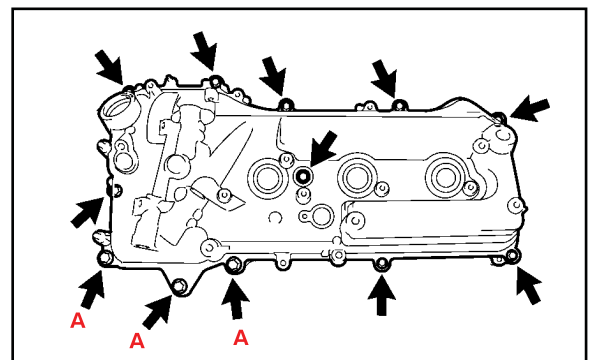

MIL "ON" DTC P0300, P0301, P0302, P0303, P0304, P0305, or P0306

Repair Procedure: Reassembly (Continued)

E. For 4WD:

Install the engine hanger with the 2 bolts.

Torque: 33 N*m (337 kgf*cm, 24 ft*lbf)

13. Install the oil pipe union bolt to the No. 2 oil pipe.

Torque: 60 N*m (612 kgf*cm, 44 ft*lbf)

Figure 75.

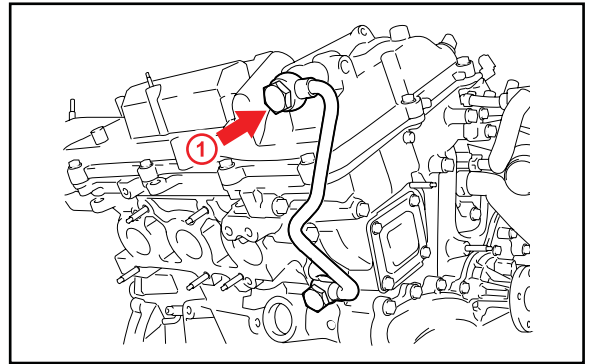

1	Oil Pipe Union
----------	-----------------------

14. Install the oil pipe union bolt to the No. 1 oil pipe.

Torque: 60 N*m (612 kgf*cm, 44 ft*lbf)

Figure 76.

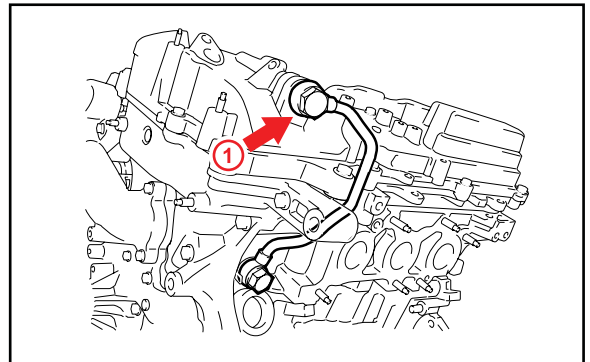

1	Oil Pipe Union
----------	-----------------------

15. Install the ignition coil assemblies.

MIL "ON" DTC P0300, P0301, P0302, P0303, P0304, P0305, or P0306

Repair Procedure: Reassembly (Continued)

16. Install the fuel pump assembly.
 - A. Turn the crankshaft until the flat of the cam is facing the cylinder head cover fuel pump attachment hole as shown in the illustration.
 - B. Pour 30 cc of engine oil into the cylinder head oil collector through the cylinder head cover fuel pump attachment hole.

Figure 77.

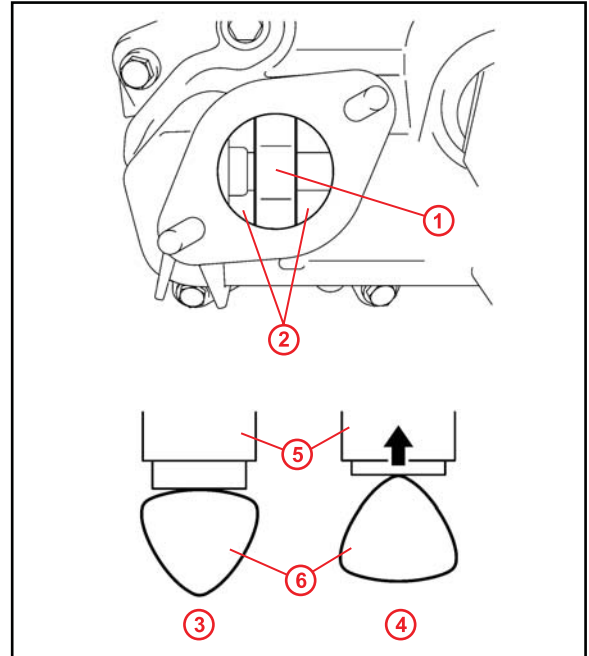

1	Camshaft
2	Oil Collector
3	CORRECT
4	INCORRECT
5	Pump
6	Cam

MIL "ON" DTC P0300, P0301, P0302, P0303, P0304, P0305, or P0306

Repair Procedure: Reassembly (Continued)

- C. Apply a coat of engine oil to the pump activation cam and pump lifter.

Figure 78.

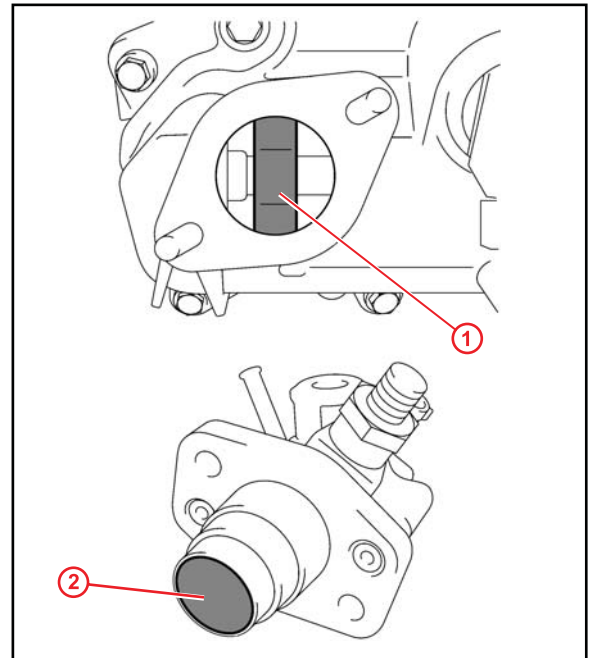

1	Camshaft
2	Pump Lifter

- D. Install the NEW fuel insulator to the cylinder head cover.

NOTE

The open sides of the metal eyelets must be facing upward as shown in the illustration.

Figure 79.

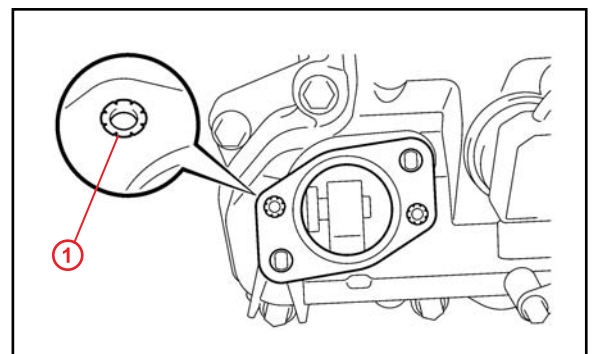

1	Metal Eyelets
---	---------------

MIL "ON" DTC P0300, P0301, P0302, P0303, P0304, P0305, or P0306

Repair Procedure: Reassembly (Continued)

- E. Temporarily install the No. 2 fuel pipe sub-assembly to the fuel pump assembly.

NOTE

Be careful NOT to damage the sealing surface of the fuel pipe when temporarily installing the fuel pipe.

Figure 80.

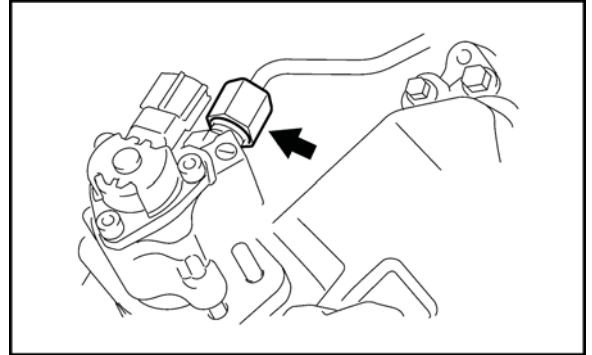

- F. Install the 2 studs.

Torque: 10 N*m (102 kgf*cm, 7 ft*lbf)

- G. Install the 2 nuts and tighten them in several passes.

Torque: 25 N*m (255 kgf*cm, 18 ft*lbf)

Figure 81.

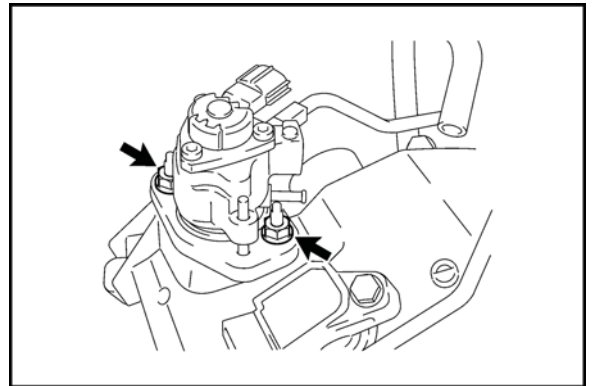

- H. Connect the fuel hose.

MIL "ON" DTC P0300, P0301, P0302, P0303, P0304, P0305, or P0306

Repair Procedure: Reassembly (Continued)

17. Connect the No. 2 fuel pipe.

A. Install the No. 2 fuel pipe to the delivery pipe with the 2 bolts.

Torque: 10 N*m (102 kgf*cm, 7 ft*lbf)

Figure 82.

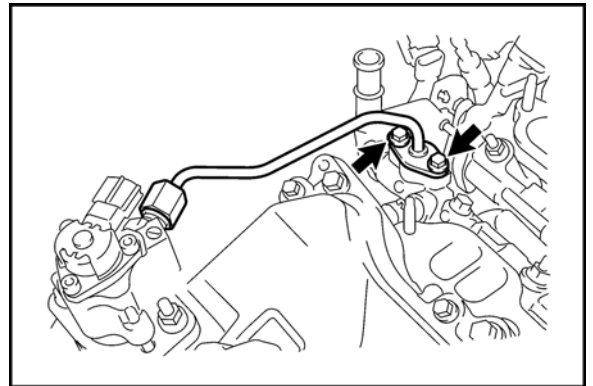

B. Using a 19-mm union nut wrench, connect the fuel pipe.

Torque: 30 N*m (306 kgf*cm, 22 ft*lbf)

Figure 83.

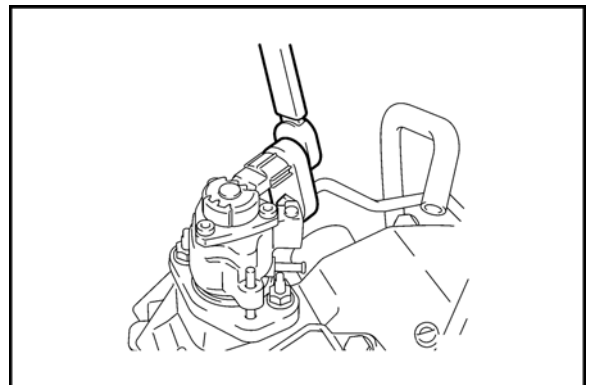

C. Connect the connector to the fuel pump.

18. Install the No. 1 fuel pipe.

A. Install the No. 1 fuel pipe with the 2 bolts.

Torque: 10 N*m (102 kgf*cm, 7 ft*lbf)

B. Connect the 2 fuel hoses.

Figure 84.

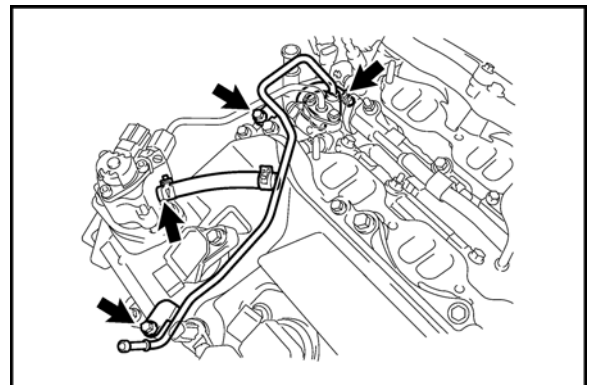

MIL "ON" DTC P0300, P0301, P0302, P0303, P0304, P0305, or P0306

Repair Procedure: Reassembly (Continued)

19. Connect the fuel main tube.
20. Install the air surge tank assembly.
 - A. Install a NEW gasket to the intake air surge tank.
 - B. Using a 5-mm hexagon socket wrench, install the 6 bolts.

Torque:
Bolts except A:
 18 N*m (184 kgf*cm, 13 ft*lbf)

Figure 85.

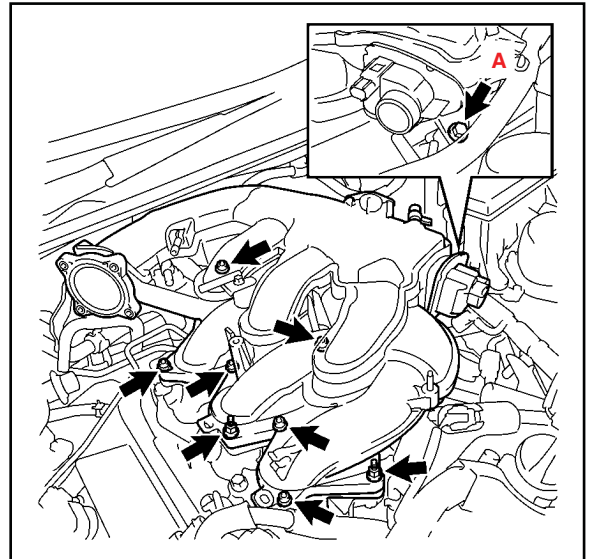

- C. Install the bolt and 2 nuts to the intake air surge tank.

Torque:
Bolt A: 21 N*m (214 kgf*cm, 15 ft*lbf)
Torque:
Nut: 16 N*m (163 kgf*cm, 12 ft*lbf)

- D. Install the surge tank stay to the intake air surge tank.

Torque:
Nut: 21 N*m (214 kgf*cm, 15 ft*lbf)

Figure 86.

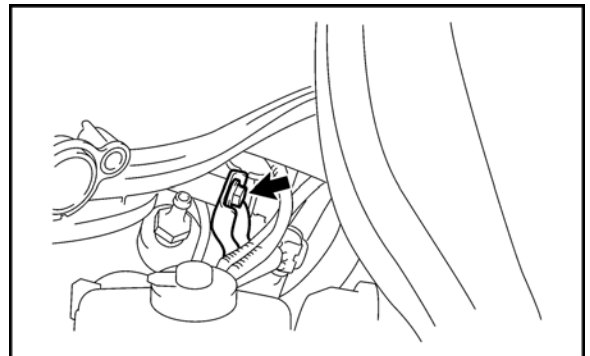

MIL "ON" DTC P0300, P0301, P0302, P0303, P0304, P0305, or P0306

Repair Procedure: Reassembly (Continued)

- E. Connect the water hose joint with the bolt.
Torque: 10 N*m (102 kgf*cm, 7 ft*lbf)

Figure 87.

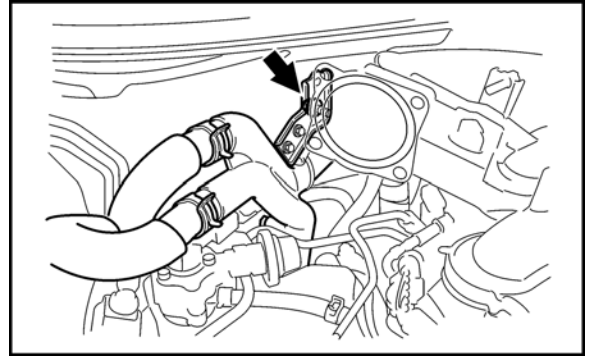

- F. Connect the ventilation hose to the intake air surge tank.

Figure 88.

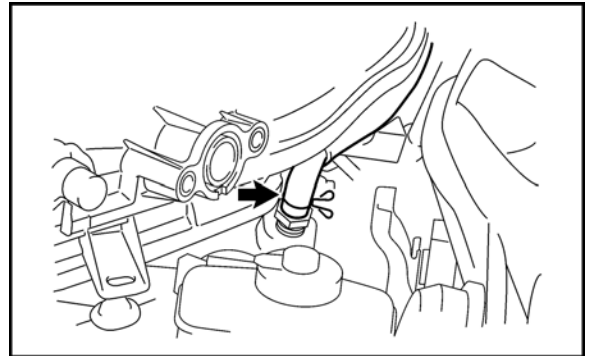

MIL "ON" DTC P0300, P0301, P0302, P0303, P0304, P0305, or P0306

Repair Procedure: Reassembly (Continued)

- G. Connect the wire harness and hose to the intake air surge tank.

Figure 89.

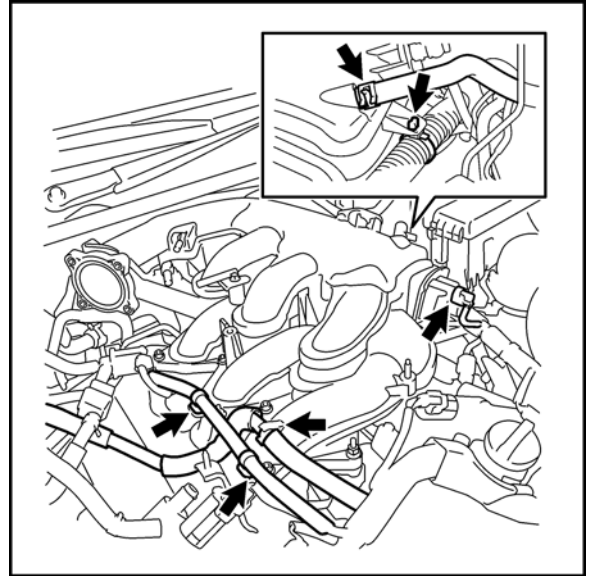

- H. Connect the No. 1 vacuum switching valve assembly to the intake air surge tank.

Torque: 18 N*m (184 kgf*cm, 13 ft*lbf)

Figure 90.

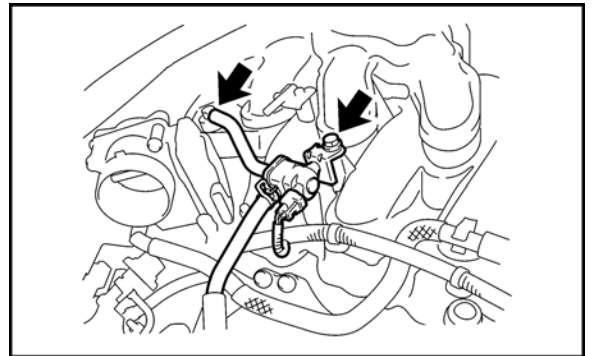

- I. Connect the vacuum hose to the intake air surge tank.

MIL "ON" DTC P0300, P0301, P0302, P0303, P0304, P0305, or P0306

Repair Procedure: Reassembly (Continued)

21. Install the throttle body assembly (with motor).

A. Install a NEW gasket to the intake air surge tank.

NOTE

- Align the protrusion of the gasket on the intake air surge tank.
- Make sure the direction of the gasket is as shown in the illustration.

Figure 91.

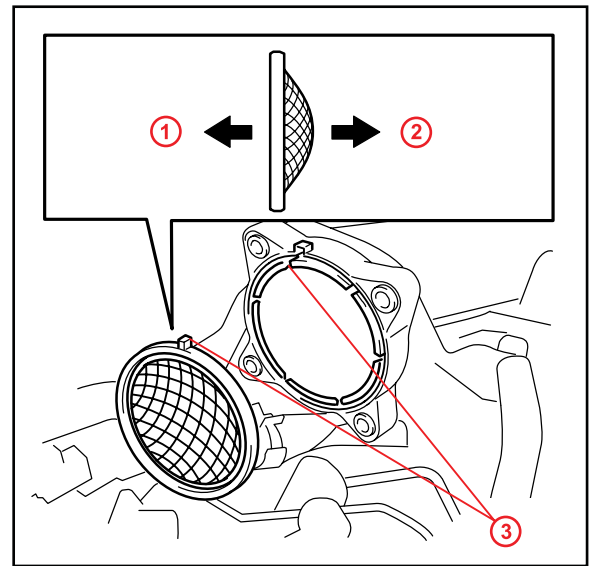

1	Throttle Body Assembly Side
2	Intake Air Surge Tank Side
3	Align

B. Install the throttle body with the 4 bolts.
Torque: 10 N*m (102 kgf*cm, 7 ft*lbf)

Figure 92.

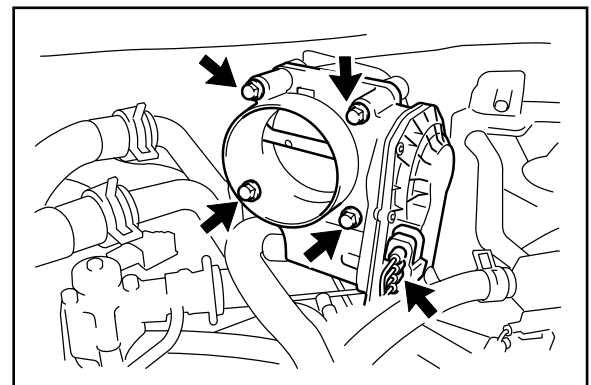

C. Connect the throttle body connector.

MIL "ON" DTC P0300, P0301, P0302, P0303, P0304, P0305, or P0306

Repair Procedure: Reassembly (Continued)

22. Connect the No. 2 fuel vapor hose.

Install the clamp and connect the No. 2 fuel vapor feed hose.

Figure 93.

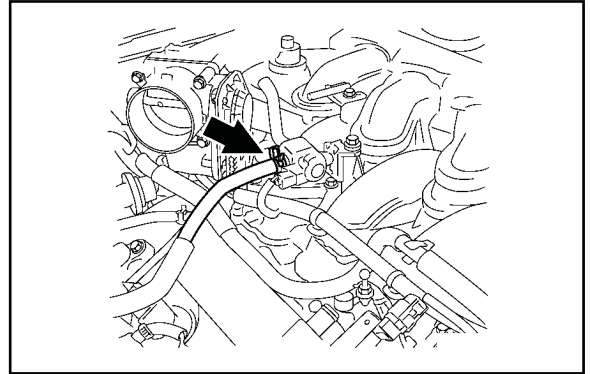

23. Connect the union to check valve hose to the surge tank.

24. Install the air cleaner case sub-assembly, clamp, and 2 bolts.

Torque: 5.0 N*m (51 kgf*cm, 44 in*lbf)

Figure 94.

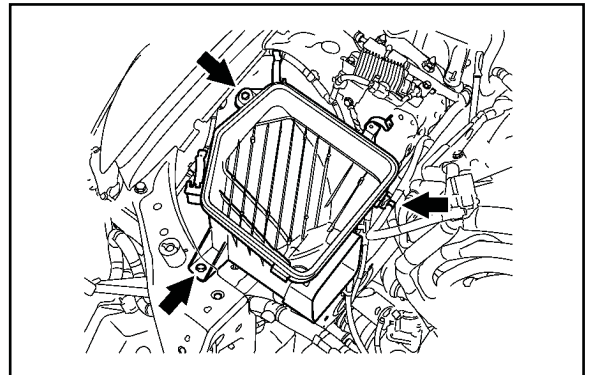

MIL "ON" DTC P0300, P0301, P0302, P0303, P0304, P0305, or P0306

Repair Procedure: Reassembly (Continued)

25. Install the air cleaner cap with air cleaner hose.

A. Install the air cleaner cap with air cleaner hose assembly with the hose clamp.

B. Install the EVAP VSV to the air cleaner hose.

Figure 95.

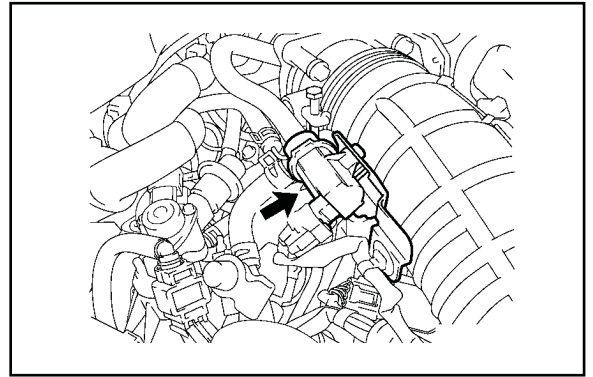

C. Connect the MAF meter connector and clamp to the air cleaner.

Figure 96.

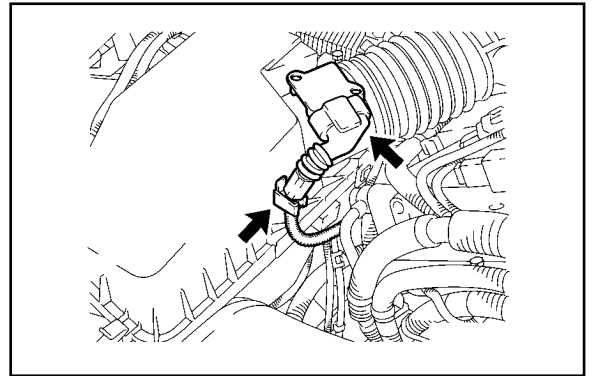

26. Connect the ventilation hose from the cylinder head.

Figure 97.

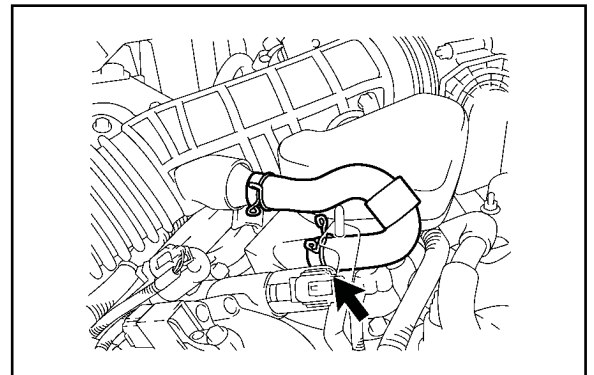

MIL "ON" DTC P0300, P0301, P0302, P0303, P0304, P0305, or P0306

Repair Procedure: Reassembly (Continued)

27. Install the No. 1 air cleaner inlet with the bolt and clip.

Figure 98.

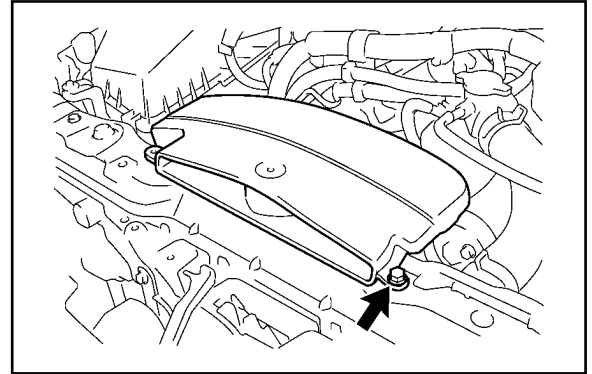

28. Connect the cable to the negative (–) battery terminal.

Torque: 5.4 N*m (55 kgf*cm, 48 in*lbf)

29. Check for fuel leaks.

- A. Connect TIS Techstream to DLC3.
- B. Turn the engine switch ON (IG). Do NOT start the engine.
- C. Enter the following menus:

Powertrain / Engine / Active Test / FUEL PUMP / SPD.

- D. Check for fuel leaks.

Check that there are NO fuel leaks anywhere in the system. If there is a fuel leak, repair or replace parts as necessary.

30. Check for engine oil leaks.

31. Check the ignition timing.

- A. Warm up the engine and then stop the engine.

NOTE

A warmed up engine should have an engine coolant temperature of over 176°F (80°C), have an engine oil temperature of 140°F (60°C), and the engine rpm should be stabilized.

- B. Start the engine and maintain engine rpm at idle speed.

MIL "ON" DTC P0300, P0301, P0302, P0303, P0304, P0305, or P0306

Repair Procedure: Reassembly (Continued)

- C. Enter the following menus on TIS Techstream:

Powertrain / Engine / Data List / IGN ADVANCE.

Ignition timing: 5 to 15° BTDC at idle

HINT

Refer to the TIS Techstream *Help* menu for further details.

- D. Check that ignition timing advances as engine speed increases.

32. Check engine idle speed.

- A. Warm up and then stop the engine.

NOTE

- A warmed up engine should have an engine coolant temperature of over 176°F (80°C), have an engine oil temperature of 140°F (60°C), and the engine rpm should be stabilized.
- Switch OFF all accessories and A/C before connecting the Techstream tester.

- B. Raise the engine speed to 2,500 rpm for approximately 90 seconds, and then return to idle.

- C. Enter the following menus:

Powertrain / Engine / Active Test / ENGINE SPD.

Idle speed: 650 to 750 rpm

NOTE

When checking the idle speed, the transmission should be in Neutral or Park.

HINT

- Refer to the TIS Techstream *Help* menu for further details.
- If the idle speed is NOT as specified, check the air intake system.

- D. Clear all DTCs.

- E. Disconnect TIS Techstream from DLC3.

33. Check the engine oil level.

Stop the engine, and wait 5 minutes. The oil level should be between the dipstick's low level mark and full level mark. If low, check for leakage and add oil up to the full level mark.

MIL "ON" DTC P0300, P0301, P0302, P0303, P0304, P0305, or P0306

Repair Procedure: Reassembly (Continued)

34. Install the V-bank cover sub-assembly.

Install the 2 nuts on the front of the cover, and then engage the clip on the rear to install the V-bank cover.

NOTE

- Be sure to engage the clip securely.
- Do NOT apply excessive force or hit the cover to engage the clip. This may cause the cover to break.

Figure 99.

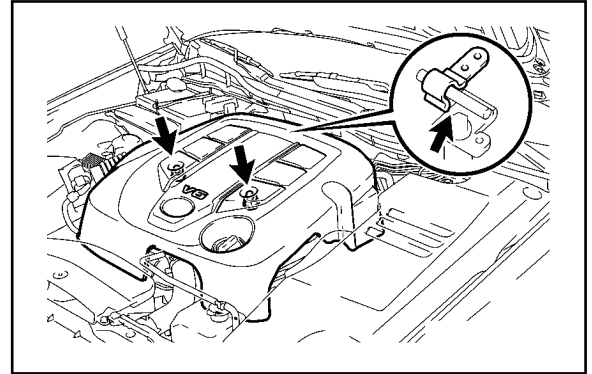

35. Install the engine compartment side cover RH with the 2 clips and nut.

Figure 100.

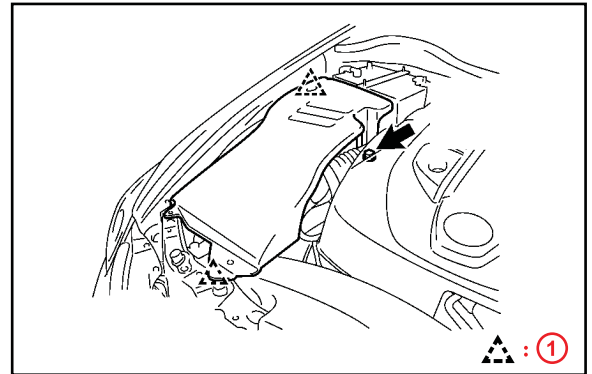

1	Clip
---	------

36. Install the engine compartment side cover LH with the 3 clips.

Figure 101.

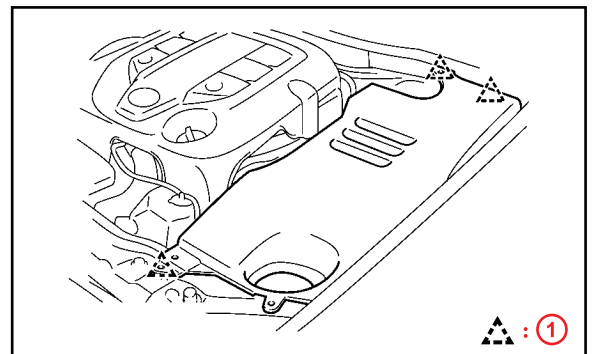

1	Clip
---	------

MIL "ON" DTC P0300, P0301, P0302, P0303, P0304, P0305, or P0306

Repair Procedure: Reassembly (Continued)

37. Install the cool air intake duct seal with the 7 clips. **Figure 102.**

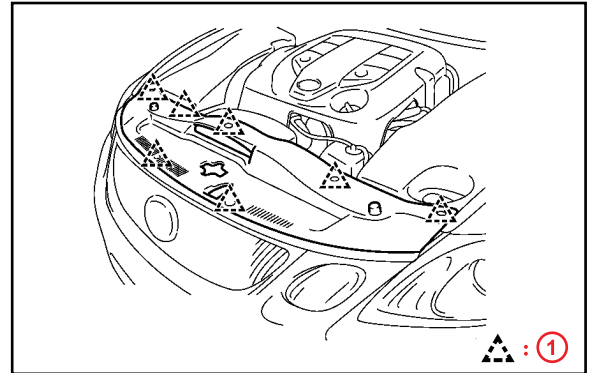

1	Clip
----------	-------------

38. Check throttle body function and throttle control motor operating sounds.
- A. Turn the engine switch ON (IG).
 - B. When pressing the accelerator pedal, check the operating sound of the running motor. Make sure that NO friction noises emit from the motor. If friction noise exists, replace the throttle body.

Figure 103.

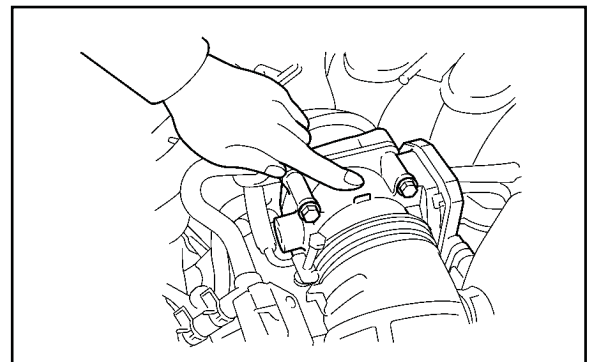

39. Re-initialize any affected power systems.

Refer to TSIB No. [PD009-06](#), "Power System Initialization During PDS."

40. Complete TSIB [L-SB-0030-10](#), "MIL 'ON' DTC P030# and/or Intermittently Runs Rough". This will complete the repair.