

NX



NX 300h | NX 200t

 LEXUS



CONTENTS

- 12 Brand Heritage
 - 14 Introducing the all-new NX
 - 16 Style and Design
 - 20 Technology
 - 22 Safety
 - 24 NX 200t and NX 300h
 - 26 Luxury and Sports Luxury
 - 28 F Sport
 - 30 Exterior Colours
 - 32 Interior Trims
 - 34 Specifications
 - 36 Ownership Solutions
 - 38 Encore Privileges
-



A CROSSOVER INSPIRED BY NO OTHER

From the time it was unveiled at the Beijing International Motor Show, the Lexus NX has captured imaginations around the world. Rather than turn to other vehicles for inspiration, Lexus took its cues from trend setting fashion labels, watches and even running shoes. The result is something genuinely fresh with thought-provoking design wedded to razor sharp technology. The NX is available as a highly refined, hybrid-bred NX 300h or an equally impressive turbo-petrol NX 200t.





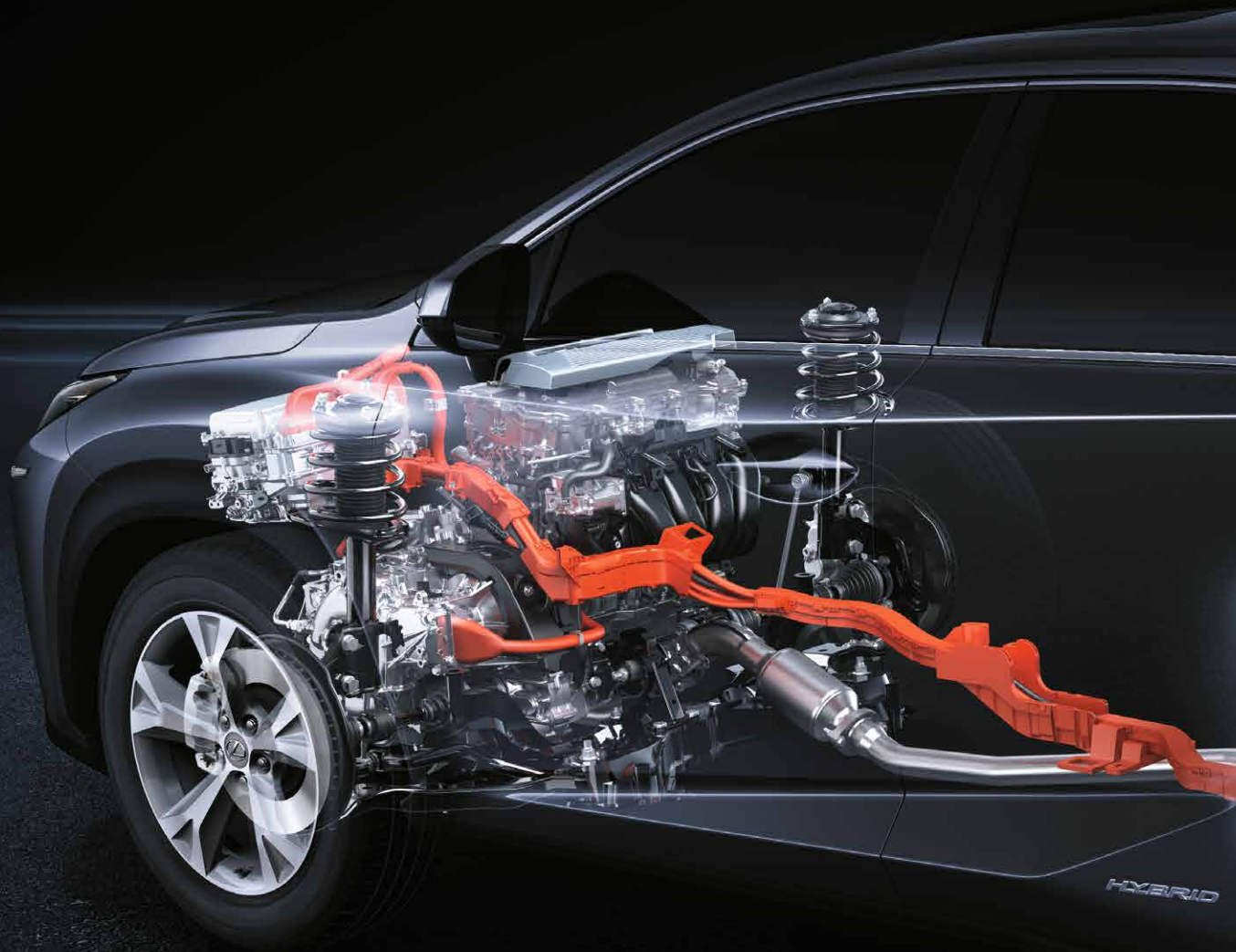

EVEN THE UNSEEN IS ATTRACTIVE

There's no question that the NX turns heads. But for all its visual appeal, its beauty runs much deeper. The 300h Hybrid drive, for example, redefines traditional thinking to deliver a surprising combination of performance and efficiency. Meanwhile, the 200t Stop & Start system saves fuel by switching the engine off when you're stopped at lights. The engine then automatically restarts as you depress the accelerator pedal. Even the ability to charge your mobile wirelessly⁽¹⁾ is a simple idea that keeps your hands on the wheel and your eyes on the road.







TIMELESS DESIGN

The NX is much like a diamond - the more you look, the more facets you see. From one angle it's a sports hatch. Look again and it's an SUV. The longer you gaze the more you see and the more you appreciate the NX's crossover nature. Here is a vehicle that's bold and unashamedly individual. As with any work of art, its beauty lies in the detail. From the exterior mirrors' subtle chrome-plated ornamentation to the strong, defiant grille, this is a vehicle that seamlessly blends functionality and aesthetics.



STOP THINKING, START FEELING

The NX's interior is so intuitive you may discover needs you never knew you had. Controls fall effortlessly to hand. Premium materials highlight its refined nature and meticulously engineered audio systems reveal new dimensions, even in music you've been listening to for years. This is an environment that simultaneously keeps you relaxed and attentive. Ergonomics and technology balance beautifully to ensure you're ready to deal with whatever the road may bring, while enjoying every minute of your trip. You see, like every pleasurable experience, time passes quickly in an NX.





A gold Lexus LS 400 is shown from a rear three-quarter view, driving on a road. The car is in the lower-left foreground, with its rear wheel and side mirror visible. The road is paved with large, light-colored concrete slabs that recede into the distance. The background is a vast, open landscape under a clear blue sky with a few wispy clouds. The lighting suggests late afternoon or early evening, with a warm glow on the car's body.

PURSUING A NEW DEFINITION OF LUXURY

In the mid 1980s, a team of passionate designers embarked on a remarkable journey. They travelled to America to immerse themselves in an exclusive neighbourhood in order to better understand the lifestyles of the privileged.

The group visited upscale boutiques and exclusive country clubs to discover the essence of western style and learn what motivated luxury vehicle buyers. Their studies unearthed a new style of luxury permeating American society. Fashion, design and architecture were being reshaped by younger, more affluent professionals who were turning their backs on conventional luxury vehicles and seeking a more rewarding driving experience.

Such a fact-finding mission was followed by one of the most extensive development programs ever undertaken by a motor vehicle company. The end result was the Lexus LS 400, a vehicle that ultimately redirected the course of luxury vehicle design, elegance and performance.

Fast-forward 30 years to the Beijing Motor Show and the unveiling of the all-new Lexus NX. Like its LS forefather, it too is visually striking, technologically intelligent and every bit a Lexus. As heads turned and cameras flashed, onlookers intuitively understood that here stood a vehicle that was anything but conventional. Here was a vehicle that didn't look to other cars for its inspiration, but to a broader, more exhilarating world. Welcome to crossover, Lexus style.



TWO SUPERB DRIVES, ONE SMALL DILEMMA

INTRODUCING THE NX

Behind its arresting L-finesse spindle grille lies a pleasant dilemma for NX buyers. Will you opt for the NX 300h with its powerful, yet efficient, 2.5 litre 4-cylinder engine supplemented by an electric motor and battery system? Or, will the NX 200t capture your imagination with its exhilarating 2.0 litre 4-cylinder turbo engine generating 175kW of power and large smiles.

As for the cockpit, it's more like a sophisticated sedan than an SUV. Lines subtly draw the eye to the instrument cluster. Controls are convenient and the driving seat offers a myriad of driving positions. For added convenience, you'll also find a wireless charging tray^(*) for your mobile.



Keeping in touch with the world is simple thanks to Enform⁽²⁾ Functionality. It delivers traffic information, weather details, the nearest service station (and prices), not forgetting information on local restaurants and florists.

Switch on the Pioneer[®] audio system⁽³⁾ and your personal orchestra of 10 speakers comes to life with sound reproduction so true it reveals dimensions in your music you've never heard before. As for the Mark Levinson[®] system,⁽³⁾ available on Sports Luxury models and optional on F Sport, you're in for an experience few have ever enjoyed.

Loading and unloading is made easier with a power-operated back door that stops the door if it detects something in its way. Heated front seats make for more comfortable cold mornings. While driving and reversing is less taxing thanks to options such as a Lexus first Panoramic View Monitor (PVM)⁽⁴⁾ and a Lane Departure Warning (LDW).⁽⁴⁾

STRIKING FROM EVERY ANGLE

STYLE AND DESIGN

The NX is a work of art. No two angles are the same, and every time you look it seems like a new vehicle. That's what you get from exceptional design. While every line, every angle and every piece of chrome is attractive in its own right, the real craft lies in ensuring they come together in a harmonious whole.

Take the front of the NX for example. Being bold and large, the L-finesse spindle grille contrasts pleasingly with the thin, sharp headlamps. Together, they present a sense of purpose and determination – it's a vehicle unashamedly 'going places'.



Wheel arches project dramatically front and rear, drawing the viewer's eye to the 18" wheels, thereby highlighting the sporting credentials of the NX. Even the 'split' bumper serves a purpose, with the upper section emphasising a low centre of gravity, while the lower part highlights the vehicle's wide stance and sure-footedness.

18" wheels are standard on all models and available in three designs. Luxury models feature a dual five-spoke wheel, the F Sport comes with dark premium metallic wheels and Sports Luxury models boast five-spoke wheels that create a real sense of depth.

Slide into the cabin and you'll find the view exceptional, especially at night. Luxury models feature LED low beam and Halogen high beam, while the F Sport and Sports Luxury models feature a three-projector LED set-up with Automatic High Beam.⁽⁵⁾

LEDs have also been adapted for the L-shaped rear combination lamps. Both the body-side and back door-side of the lamp illuminates to clearly distinguish the NX from other vehicles. Even in the dark, it's a Lexus.



NX 300h Sports Luxury shown



NX 300h F Sport shown



NX 300h F Sport shown



Wireless charger*



Sports Luxury power 60:40 split fold seats
Overseas model shown



Lexus Remote Touch (LRT)



THE PLEASURE IS IN THE DETAIL

STYLE AND DESIGN

From relaxation to concentration and everything in between, you do a lot in your car. So the NX's interior is designed to ensure things happen effortlessly and as safely as possible.

In keeping with its crossover concept, the NX instrument panel and console tend to merge into one. As the console gently cascades towards the floor, it wraps around your legs, creating a snug cockpit feel and accentuating the interior's ergonomics. Speaking of which, the Lexus Remote Touch (LRT) interface ensures that controls are exactly where you'd expect them to be without having to 'feel' for them.

Lexus' human/machine interface thinking is evident wherever you look. This is the study of how people interact with their vehicles and how Lexus makes this interaction more productive.



NX 300h Sports Luxury model shown

A good example is how the NX display zones are separated from its operational zones. The instrument cluster, for example, is clearly separated from the fingertip steering controls, so your attention remains focused not distracted.

Speaking of instrument panels, the F Sport model's instruments are ringed with white outer bandings to reflect its sports credentials and to pay homage to the Lexus LFA and IS F instrument clusters.

The interior of the Luxury model is wrapped in NuLux™, a new synthetic material which provides a sleek, contemporary look. Meticulous attention to detail is further evidenced in the leather accents that complement the seats of the F Sport and Sports Luxury. Structural elements on the other hand, such as

handles, gearshifts and paddles, are highlighted with a metallic look for aesthetic and functional purposes. As for pure practicality, all NX models are fitted with a power back door. This can be operated from switches located on the instrument panel, your wireless key or at the rear of the vehicle. Better still, a memory function allows you to pre-determine an opening height that's most convenient for you.

Sports Luxury power 60:40 split fold seats can be operated via switches on the side of the rear seat, driver seat or from within the luggage compartment. Both the power back door and rear seat can be operated from the driver's seat. And as further proof that no NX corner has been cut, Lexus have even illuminated footwells to create a pleasant environment around the seats.

*Available on F Sport and Sports Luxury models. Only Qi-supported devices are compatible. Refer to your device manufacturer to determine your device's compatibility. Some devices may require the purchase of a Qi-supported accessory to enable wireless charging.

INTUITIVELY INNOVATIVE

TECHNOLOGY

It's amazing how quickly we adapt to new technology - if it's useful and intuitive. Take the Panoramic View Monitor (PVM)⁽⁴⁾ that's standard in the F Sport and Sports Luxury. It combines images from various cameras mounted on the vehicle to deliver you an uninterrupted view of what's happening around you.

Keeping your eyes on the road is also simpler thanks to a colour Head Up Display (HUD) found on the Sports Luxury models and the F Sport Enhancement Pack 2. The system projects key information, such as speed and tachometer readings, onto the windscreen in line with the driver's vision.

A Multi-Information Display (MID) keeps you in touch with incoming calls and navigation⁽⁸⁾ directions for example. And in the interests of safety, the display can be controlled through steering wheel buttons. As for the navigation function,⁽⁸⁾ it gives you a graphic display of surrounding road conditions for city driving.



7" display shown

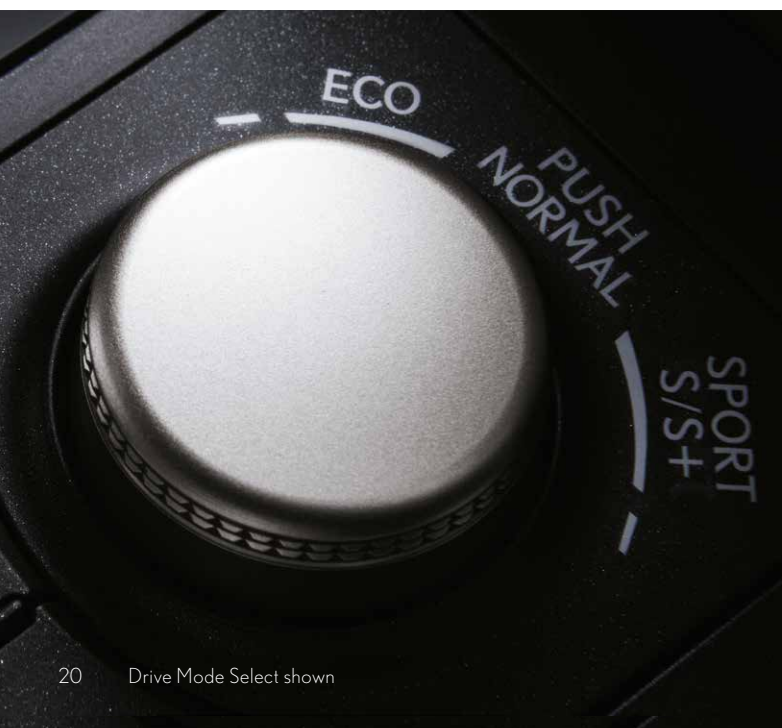

20 Drive Mode Select shown



NX 200t boost meter shown

Since not all drivers have similar driving styles and not all road conditions are the same, the NX comes with a Drive Mode Select system. Luxury models feature three driving modes: Eco, Normal and Sport, while F Sport and Sports Luxury models feature an extra mode, Sport S+. An Electric Vehicle (EV) mode is standard on 300h models.

As its name suggests, the Eco mode aids in smoother, more efficient driving. The Normal mode delivers a balance between performance and economy. As for the Sport mode, the power steering and powertrain, which includes the engine, hybrid system and transmission, are monitored and their performance automatically altered as required. This results in even more responsive acceleration.

To ensure you know which driving mode you're in, the Multi-Information Display changes its background illumination from blue for Normal and Eco modes to red for Sports mode. The 200t F Sport model's Multi-Information Display also

includes a Boost Meter that varies colour when you're driving in the high boost range. Oil temperature and pressure readouts are displayed at the bottom of the boost meter. For greater control, this model also incorporates a G Sensor that displays G force information, steering angle, accelerator opening angle and brake pressure readouts.

Come sunset, an Automatic High Beam system⁽⁶⁾ fitted to F Sport Enhancement Pack 2 and Sports Luxury models, turns the high beam off when another vehicle is detected. Then, when the road is clear, the high beam reactivates for greater visibility. And for further safety, your NX is equipped with fog lamps that activate individually as you turn a corner. So, for example, if you're turning a left hand corner, the left fog lamp illuminates for better vision.

And to keep things right at your very fingertips, the Lexus Remote Touch features a smartphone style touchpad to help you control a range of features. A palm rest supports the wrist and hand when operating the keypad.



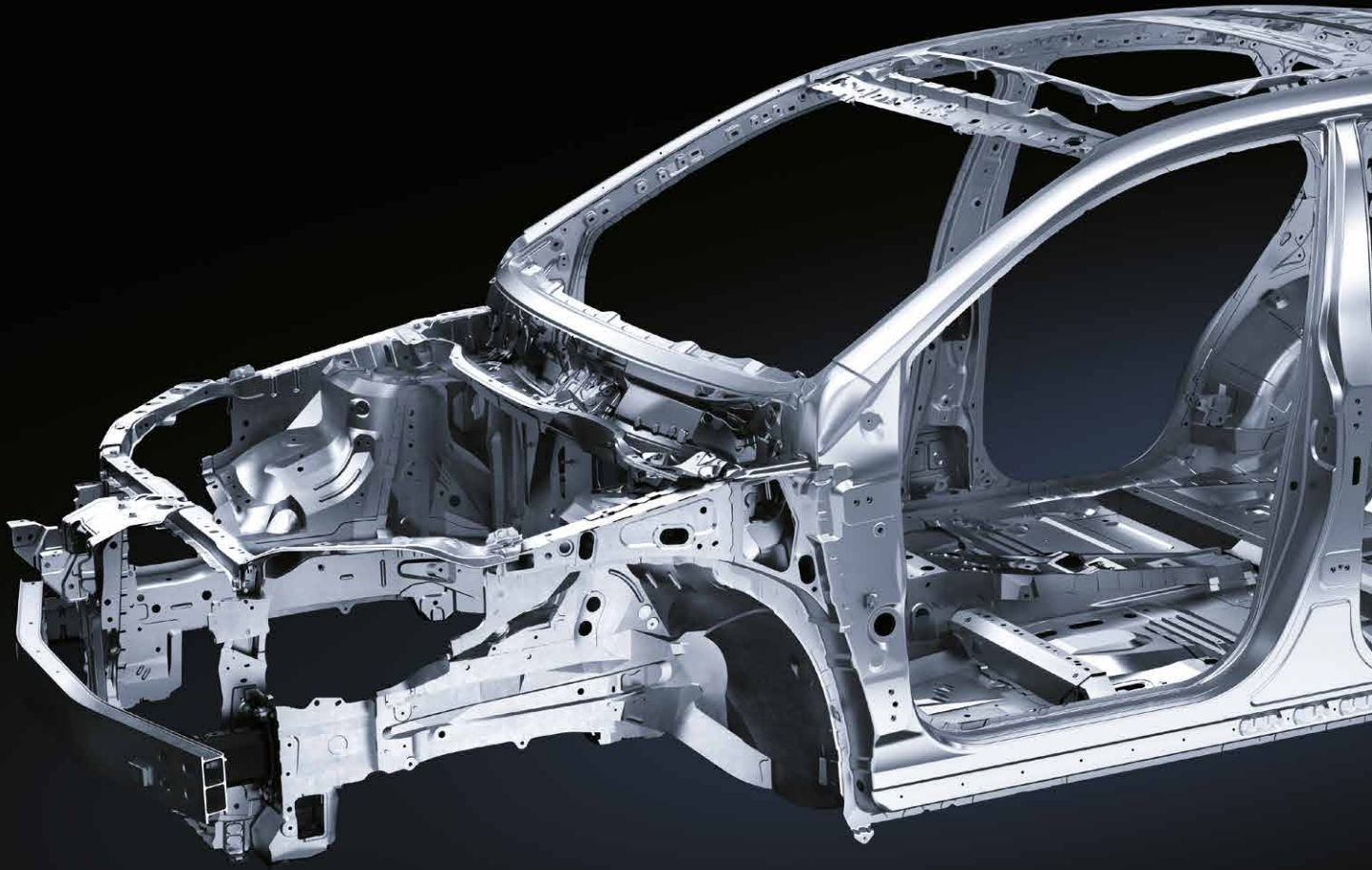



SAFETY FIRST, SECOND, THIRD...

SAFETY

Safety is not just a measure of air bags. It's a combination of features and technology working together with split second precision in the event of a collision. The NX's body structure for example, is designed to absorb shock and disperses energy away from the vehicle's cabin in the event of a crash. Eight strategically placed SRS airbags are armed to deploy at a speed significantly faster than the blink of an eye.

As for times when surrounding vehicles can't be seen from within the vehicle, F Sport and Sports Luxury models feature a Blind Spot Monitor (BSM)⁽⁶⁾ with Rear Cross Traffic Alert System (RCTA).⁽⁶⁾ Using a sophisticated wave radar program, it alerts the driver to unseen vehicles in adjacent lanes by illuminating an indicator on the appropriate exterior mirror.

Prototype model shown



Blind Spot Monitor (BSM)



Rear Cross Traffic Alert (RCTA)
Illustrative purposes only

NEXT LEVEL PERFORMANCE

2.0 LITRE TURBO

The NX 200t features a turbocharged 2.0 litre 4 Cylinder Atkinson cycle engine that delivers 175kW @ 4,800-5,600rpm and 350Nm @ 1,650-4,000 rpm. It also delivers a world-first, courtesy of a cylinder head with an integrated 4-into-2 exhaust manifold and twin scroll turbocharger.

The Atkinson cycle engine's high compression ratio makes for excellent torque, superb throttle responsiveness and equally impressive fuel economy. The twin scroll turbocharger also provides power right through the rpm range, so the power is there whenever you may need it.





Overseas NX 200t F Sport model shown

HYBRID INTELLIGENCE, CROSSOVER CONVENIENCE

HYBRID

The NX 300h's powertrain achieves the seemingly impossible—enhanced performance and enhanced efficiency. It consists of an electric motor with reduction gear and generator coupled to a power-split device. This divides the engine's power into electrical and mechanical.

To ensure the Hybrid's battery doesn't encroach on the luggage space, the pack is separated into two units under the rear seats.

As for cooling and noise reduction, ducts are located on either end of the seat.

The AWD 300h also includes an electric motor on the rear axle that enables the vehicle's AWD operation. Finally, sporty, manual-like shifting of the six stepped transmission ratios is available through the shift lever and steering wheel paddles.



Overseas NX 300h Luxury model shown

SEE, HEAR, FEEL, DRIVE THE DIFFERENCE

SPORTS LUXURY

It doesn't come any more premium than the Sports Luxury, with a beautifully balanced combination of luxury feel and sports styling. Here you'll find all the features you'd expect of the top of the line, including a stunning audio system.

- 18" Sports Luxury Alloy Wheels
 - Pre-Collision Safety System (PCS)⁽¹⁰⁾
 - All Speed Active Cruise Control (ACC)⁽¹⁰⁾
 - Lane Departure Warning (LDW)⁽⁴⁾
 - 60:40 Power Recline & Fold Rear Seat
 - Satellite Navigation⁽⁸⁾ and Mark Levinson[®] 14-speaker Audio
 - Shimamoku Ornamentation (or Bamboo Ornamentation 300h only)
 - Wireless Charger⁽¹⁾
 - EC Interior and Exterior Mirrors
 - Heated and Ventilated Front Seats
 - Colour Head Up Display (HUD)
 - Moonroof
 - Adaptive Variable Suspension
 - Front/Rear Performance Body Dampers
 - Full LED Headlamps (high and low beam)
 - Automatic High Beam
 - Panoramic View Monitor (PVM)⁽⁴⁾
 - 10-way Powered Driver's Seat with Memory
 - Smart Key Card
 - Blind Spot Monitor (BSM)⁽⁶⁾ with Rear Cross Traffic Alert (RCTA)⁽⁶⁾
-

LUXURY LIKE NEVER BEFORE

LUXURY

Step into luxury on a level of its own. Here you'll find a model that is chic, contemporary and tasteful. So sit back, relax and discover that with the NX Luxury, driving pleasure starts well before you start the engine.

2.5 litre full hybrid with 147kW and Continuously Variable Transmission (CVT) with six stepped ratios or

2.0 litre Turbo with 175kW and Six-speed Automatic Transmission

18" Alloy Wheels

Premium Steering Wheel

Cruise Control

Drive Mode Select

7" Colour Display

Rear View Camera

Parking Sensors (front and rear)

Electronic Park Brake

Satellite Navigation System⁽⁸⁾

10-speaker Audio System

3rd Generation Remote Touch

DAB+⁽³⁾

4.2" LCD Multi-Information Display

NuLux™ Seat Trim

Heated Front Seats

4-way Power Steering Column Adjustment

Power Back Door

8 SRS Airbags

Rain-sensing Wipers

EC Interior Mirror

LED Low Beam Headlamp

ABS, Electronic Brakeforce Distribution (EBD),

Brake Assist (BA), Hill Start Assist Control

(HAC), Vehicle Stability Control (VSC) and Traction Control (TRC)⁽⁹⁾

LUXURY ENHANCEMENT PACK 1

Moonroof

LUXURY ENHANCEMENT PACK 2

Moonroof, All Speed Radar Active Cruise Control

(ACC)⁽¹⁰⁾ Pre-Collision Safety System (PCS)⁽¹⁰⁾



A PERFORMANCE NOT TO BE MISSED

F SPORT

Practicality meets performance with the F Sport. Interior features and finishes which feel as if they've been taken straight from a sports car give the vehicle real edge. Cut to the exterior and you'll find aggressive 18" wheels that give the F Sport a distinct sense of purpose.

- F Sport Front Bumper and Grille
- F Sport 18" Alloy Wheels
- F Sport Leather Accented Trim
- F Sport Steering Wheel
- F Sport Gear Lever
- F Sport Badging
- F Sport Pedals
- F Sport Wedge Metal Ornamentation
- F Sport Scuff Plates
- Full LED Headlamps (high and low beam)
- Adaptive Variable Suspension
- Front/Rear Performance Body Dampers
- Panoramic View Monitor (PVM)⁽⁴⁾
- 10-way Powered Driver's Seat with Memory
- Heated, Ventilated Front Seats
- Satellite Navigation⁽⁸⁾ and 10-speaker Audio
- Wireless Charger⁽¹⁾
- EC Interior and Exterior Mirrors
- Blind Spot Monitor (BSM)⁽⁶⁾ with Rear Cross Traffic Alert (RCTA)⁽⁶⁾

F SPORT ENHANCEMENT PACK 1

- Mark Levinson[®] 14-speaker Audio System
- Moonroof

F SPORT ENHANCEMENT PACK 2

- Mark Levinson[®] 14-speaker Audio System⁽¹⁰⁾
- Pre-Collision Safety System (PCS)⁽¹⁰⁾
- All Speed Radar Active Cruise Control (ACC)⁽¹⁰⁾
- Lane Departure Warning (LDW)⁽⁴⁾
- Automatic High Beam
- Colour Head Up Display (HUD)
- Smart Key Card
- Moonroof





THE FINISHING TOUCH

EXTERIOR COLOURS

When it comes to putting the finishing touches to your NX, you'll find you're spoilt for choice. The NX Luxury and Sports Luxury models offer 10 colours and the F Sport offers nine.

You'll also find the paint is highly scratch resistant and self-restoring,⁽¹⁶⁾ as first seen on the Lexus LS. It's a system that proves particularly effective in reducing scratches from car washes or from fingernails around door locks for example. Better still, this paint system also helps preserve the gloss level of the paint as the vehicle ages.



Sonic Quartz[^]

085



White Nova[^]
F Sports Models only

083



Premium Silver[^]

114



Titanium[^]

117



Mercury Grey[^]

1H9



Onyx

212

The colour palette also includes Sonic Quartz[^]. In terms of paint finishes, it's the purest white you can find in automotive paint finishes. And while we won't go into great detail, we will say its sonic technology separates the paint into two layers: a cosmetic one and a functional layer, to deliver a super finish.

Lexus Australia reserves the right to vary and discontinue the current interior and exterior colours, trims and colour/trim/model combinations. Colours and trims displayed here are a guide only and may vary from actual colours due to printing/display process. See your Lexus dealer to confirm colour/trim/model availability when ordering your vehicle. Metallic/mica pearlescent paint is optional and subject to additional charges on most models.

[^] Premium paint featured is an optional extra



Graphite Black[^]

223



Vermillion[^]

3R1



Deep Metallic Bronze[^]
Luxury and Sports Luxury models only

4X2



Flame Blue[^]

8U1



Sparkling Meteor[^]
Luxury and Sports Luxury models only

8X9



Luxury



F Sport



Sports Luxury

AN EYE FOR DETAIL, A FEEL FOR COMFORT

INTERIOR TRIMS



Black trim
Luxury model shown



Black/Garnet trim
Luxury model shown



Black/White trim
Luxury model shown



Topaz Brown trim
Luxury model shown



White/Black trim
Sports Luxury model shown



Black trim
Sports Luxury model shown



Shimamoku



Bamboo



Wedge Metal

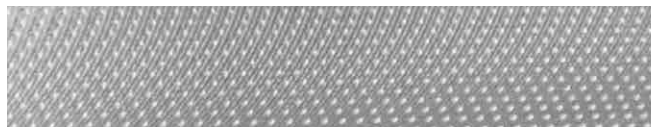

Silver Film

And so we come to the final touch. Luxury models feature NuLux™ seat trim combined with a lateral quilted design to give a clean, contemporary style. This is topped off with silver ornamentation.

The Sports Luxury model offers a dynamic look thanks to a choice of six colour leather accents and an upward quilting design. Exquisite Shimamoku ornamentation and silver metallic moulded accents complete the picture.

As for the F Sport, leather accents and a further variant on lateral quilting highlight the sculpting of the front seats and creates a sporting style. This model also features Wedge Metal ornamentation, while the 300h Sports Luxury model boasts a unique Bamboo ornamentation.

Lexus Australia reserves the right to vary and discontinue the current interior and exterior colours, trims and colour/trim/model combinations. Colours and trims displayed here are a guide only and may vary from actual colours due to printing/display process. See your Lexus dealer to confirm colour/trim/model availability when ordering your vehicle.



White/White trim
Sports Luxury model shown



Black/Saddle Tan trim
Sports Luxury model shown



Black trim
F Sport model shown



Black/Garnet trim
Sports Luxury model shown



Black/Dark Rose trim
F Sport model shown



Dark Rose trim
F Sport model shown



Bamboo trim
Sports Luxury shown

NX GENERAL SPECIFICATIONS

		NX 300h 2WD/AWD	NX 200t 2WD/AWD
EXTERIOR ⁽¹⁷⁾	Length (mm)	4630	4630
	Width (mm) - mirrors folded in	1870	1870
	Height (mm)	1630	1630
	Wheelbase (mm)	2660	2660
	Ground Clearance (mm)	185	190
	Front Track (mm)	1580	1580
	Rear Track (mm)	1580	1580
	Coefficient Drag (CD)	0.33	0.33/0.34
INTERIOR ⁽¹⁷⁾	Effective Leg Room Front (mm)	1088	1088
	Effective Leg Room Rear (mm)	918	918
	Shoulder Room Front (mm)	1455	1455
	Shoulder Room Rear (mm)	1405	1405
	Hip Room Front (mm)	1400	1400
	Hip Room Rear (mm)	1370	1370
	Interior Length (mm)	2080	2080
	Interior Width (mm)	1520	1520
	Interior Height (mm)	1180	1180
WEIGHTS AND CAPACITIES	Kerb Weight (kg) ⁽¹⁴⁾	1740-1835/1800-1895	1700-1790/1755-1860
	Gross Vehicle Mass (kg) ⁽¹⁵⁾	2325/2385	2280/2350
	Seating Capacity	5	5
	Luggage Capacity - Rear Seat Standard Position	475	500
	Luggage Capacity - Rear Seat Folded	1520	1545
	Fuel Tank Capacity	56	60
BODY	Body Construction	Monocoque	Monocoque
	Body Type	5-door Wagon	5-door Wagon
ENGINE	Engine Type	Petrol Electric Hybrid	Petrol
	Engine Capacity (cc)	2494	1998
	Engine Code Name	2AR-FXE	8AR-FTS
	Engine Description	16-Valve, 4 Cylinder In-line Type, Atkinson Cycle, DOHC, VVT-i	16-Valve, 4 Cylinder In-line Type, DOHC, VVT-iW (intake) and VVT-i (exhaust)
ELECTRIC MOTOR	Type	Permanent Magnet Synchronous Motor	-
POWER AND TORQUE	Maximum Power (kW)	147kW @ 5,700rpm (total system output)	175kW @ 4800-5600rpm
	Maximum Torque (Nm)	210Nm @ 4,200-4,400rpm (petrol engine)	350Nm @ 1650-4000rpm
	Fuel Economy (combined, L/100km) ⁽¹⁸⁾	5.6/5.7	7.7 / 7.9
	Carbon Dioxide (g/km) ⁽¹³⁾	131/133	178 / 184
HYBRID SYSTEM	Type	Series/Parallel	-
HIGH VOLTAGE BATTERY	Type	NiMH	-
DRIVETRAIN	Drivetrain	2WD/AWD	2WD/AWD
	Driven Wheels	Front/Front & Rear	Front/Front & Rear
	Transmission Description	Continuously Variable Transmission (CVT)	6 Speed Automatic Transmission
STEERING	Steering Type	Rack and Pinion	Rack and Pinion
	Steering Operation	Electronic Power Steering (EPS)	Electronic Power Steering (EPS)
	Turning Circle at (kerb to kerb m)	11.4	11.4
BRAKES	Front	Ventilated Disc	Ventilated Disc
	Rear	Solid Disc	Solid Disc
	Regenerative Braking System	.	-
SUSPENSION	Front Suspension	MacPherson Struts and Lower Arms	MacPherson Struts and Lower Arms
	Rear Suspension	Trailing Arm with Double Wishbone	Trailing Arm with Double Wishbone
TYRES AND RIMS	Front/Rear Tyre & Size	225/60R18 100H - Luxury 235/55R18 100V - F Sport 225/60R18 100H - Sports Luxury	225/60R18 100H - Luxury 235/55R18 100V - F Sport 225/60R18 100H - Sports Luxury
	Front/Rear Rim Size (in)	18"	18"
	Rim Type	5-spoke U Shaped Alloy - Luxury Dual 5-spoke Alloy - F Sport 5-spoke Y Shaped Alloy - Sports Luxury	5-spoke U Shaped Alloy - Luxury Dual 5-spoke Alloy - F Sport 5-spoke Y Shaped Alloy - Sports Luxury
	Spare Tyre	Space Saver	Space Saver

NX ADVANCED FEATURES

LUXURY

F SPORT

SPORTS LUXURY

Traction Control	•	•	•
Vehicle Stability Control (VSC)	•	•	•
Electronic Brakeforce Distribution (EBC)	•	•	•
Anti-lock Braking System (ABS)	•	•	•
Pre-Collision Safety System (PCS) ⁽¹⁰⁾ with Pre-Collision Braking (PCB) ⁽¹⁰⁾	EP2	EP2	•
8 Supplemental Restraint System (SRS) Airbags	•	•	•
Cruise Control	•	•	–
All Speed Radar Active Cruise Control (ACC) ⁽¹⁰⁾	EP2	EP2	•
Blind Spot Monitor (BSM) ⁽⁶⁾ with Rear Cross Traffic Alert (RCTA) ⁽⁶⁾	–	•	•
Lane Departure Warning + (LDW+) ⁽⁴⁾	–	EP2	•
Rear View Camera with Panoramic View ⁽⁷⁾	–	•	•
Rear View Camera ⁽⁷⁾	•	–	–
Parking Sonar (Front & Rear) ⁽⁷⁾	•	•	•
Hill-start Assist Control (HAC) ⁽⁹⁾	•	•	•
Power Driver's Seat	8-way Power Seat	10-way Power with Memory	10-way Power with Memory
Power Passenger seat	8-way Power Seat	8-way Power Seat	8-way Power Seat
Switchable Hybrid System Indicator/Tachometer	NX 300h	NX 300h	NX 300h
Adaptive Variable Suspension	–	•	•
Colour Head Up Display (HUD)	–	EP2	•
Smart Entry	•	•	•
Smart Key Card	–	EP2	•
Push Button Start	•	•	•
Leather Steering Wheel with Paddle Shift	•	•	•
Dual-zone Climate Control	•	•	•
NuLux™ Interior	•	–	–
Leather Accented Seats	–	•	•
Heated Front Seats	•	•	•
Cooled and Ventilated Front Seats	–	•	•
Power Recline & Fold 60:40 Rear Seat	–	–	•
Moonroof	EP1, EP2	EP1, EP2	•
Lexus Remote Touch Controller (LRT)	•	•	•
Satellite Navigation System ⁽⁶⁾	•	•	•
Enform Functionality ⁽²⁾	•	•	•
4.2" LCD Multi Information Display (MID)	•	•	•
Boost Meter & G Sensor	–	NX 200t	–
Tyre Pressure Warning System	•	•	•
Bluetooth® Mobile Phone Connectivity ⁽¹¹⁾	•	•	•
Self-dimming Interior Mirror	•	•	•
Digital Radio (DAB+) ⁽³⁾	•	•	•
Single Disc CD with 10-speaker Audio	•	•	–
14-speaker Mark Levinson® Audio with USB Connection for iPod® ⁽¹²⁾	–	EP1, EP2	•
Wireless Charger ⁽¹⁾	–	•	•
Rear Privacy Glass	•	•	•
Power Back Door	•	•	•
18" Alloy Wheels	•	•	•
Rain-sensing Wipers	•	•	•
Daytime Running Lights (DRL)	•	•	•
LED Low Beam	•	•	•
LED High Beam	–	•	•
LED Fog Lights	•	•	•
LED Rear Combination Lamp	•	•	•
Anti-theft Siren and Intrusion Sensor	•	•	•
Performance Rod	•	–	–
Performance Dampers	–	•	•
LUXURY ENHANCEMENT PACK 1	Moonroof		
LUXURY ENHANCEMENT PACK 2	Moonroof, All Speed Radar Active Cruise Control (ACC) ⁽¹⁰⁾ , Pre-Collision Safety System (PCS) ⁽¹⁰⁾		
F SPORT ENHANCEMENT PACKAGES	Enhancement Pack 1: Mark Levinson® 14-speaker Audio System, Moonroof Enhancement Pack 2: Mark Levinson® 14-speaker Audio System, Moonroof, Pre-Collision Safety System (PSC) ⁽¹⁰⁾ All Speed Radar Active Cruise Control (ACC) ⁽¹⁰⁾ , Lane Departure Warning (LDW) ⁽⁴⁾ , Auto High Beam, ⁽⁵⁾ Colour Head Up Display (HUD), Smart Key Card		



A vertical photograph on the left side of the page shows a person's hand in a blue sleeve at the top left and a golden retriever running through a field of dry grass towards the right. The background is a bright, hazy sky.

OWNERSHIP SOLUTIONS

OWNERSHIP SOLUTIONS ALLOWS YOU TO DETERMINE YOUR FINANCE COSTS AND KNOW THE GUARANTEED FUTURE VALUE (GFV)⁺ OF YOUR VEHICLE FROM THE OUTSET. IT OFFERS YOU CHOICE, CONTROL AND CERTAINTY. IN SHORT, EVERYTHING YOU'D EXPECT FROM LEXUS.

How does Ownership Solutions work?

- You choose the deposit that best fits your needs.
- You choose your term.⁺⁺
- We agree on the estimated kilometres you think the vehicle will have travelled at the end of the term (the End Odometer). The End Odometer will also include any kilometres already on the vehicle.
- Lexus Financial Services (LFS) then determines the GFV of your vehicle. The GFV is the minimum value of your Lexus at the end of your finance contract. Your monthly repayments are then calculated based on the above information with a final payment equal to your GFV. Then, if you return your Lexus at the end of the term and satisfy the agreed terms and conditions, LFS will pay you the GFV which will be put against the final payment.

The end of the term? Simply replace, retain or return.

At the end of your term you can choose to:

- Replace or sell your Lexus using the trade-in value or sale price to pay the remaining balance of your account.
- Retain your Lexus and simply pay the remaining balance of your account (including final payment).
- Alternatively, return your Lexus and, subject to fair wear and tear conditions and the agreed kilometres being met, we'll put the GFV towards the final payment on your account.

Choosing your deposit – what is best for you?

With the flexibility of Ownership Solutions, you can choose the deposit that best fits your current needs.

- If, for example, you have funds tied up in other investments, you can choose to finance your new Lexus with a zero deposit.⁺⁺
- Alternatively, by using a larger deposit you can lower your monthly repayments.
- Better still, compared to other finance options over a similar term, Ownership Solutions can provide more affordable monthly repayments.⁺⁺⁺

Want more certainty?

With Ownership Solutions, you've got the reassurance that at the end of the term (subject to fair wear and tear and agreed kilometres being met) you'll never owe more than your vehicle's worth to LFS. In other words, you don't have to worry about what your vehicle will be worth in the future because you know its minimum value from the outset.

What happens in the case of the unexpected?

If your vehicle incurs damage and does not meet the Fair Wear and Tear guidelines, LFS will give you the opportunity to have your vehicle repaired. Otherwise, LFS can organise the repairs and deduct the cost from your GFV. This adjusted GFV will then be the price that LFS will offer you if you return the vehicle at the end of your term. Of course, if you retain the vehicle, the condition doesn't matter; however, if you replace it or sell it privately, the condition will obviously impact your sale price.

So what does your accountant think?

Naturally, we think Ownership Solutions is an excellent, innovative way to put you in control of buying a new Lexus. That said, we suggest you seek independent advice to ensure Ownership Solutions is right for you.

Wouldn't it be great if Ownership Solutions was just the beginning?

Lexus' innovations and commitment to customer service extend well beyond Ownership Solutions. Once you purchase a new Lexus, you'll become a member of the Lexus Encore Privileges Programme and enjoy a host of exclusive benefits.[†]

For further details, simply visit your nearest Lexus dealer or see lexus.com.au/services/benefits/

⁺ Guaranteed Future Value (GFV) is the minimum value of your new or approved demonstrator Lexus at the end of your finance contract, as determined by Lexus Financial Services (LFS). If you decide to return your car to Lexus at the end of your term, (LFS) will pay you the agreed GFV amount which will be put against your final payment, subject to fair wear and tear conditions and agreed kilometres being met. The information provided is general in nature. You should seek your own financial advice to determine whether Lexus Ownership Solutions is appropriate for your individual circumstances. Terms and conditions, fees and charges apply. Lexus Ownership Solutions GFV products are available to approved customers of Lexus Financial Services, a division of Toyota Finance Australia Limited ABN 48 002 435 181, Australian Credit Licence 392536.

⁺⁺ Up to four years.

⁺⁺⁺ Lower monthly repayments compared to similar term with no Guaranteed Future Value (GFV) or equivalent balloon final payment. Total interest charges will be higher if a GFV or balloon final payment is selected.

[†] Terms and Conditions apply.





THE BENEFITS OF ENCORE

THE BENEFITS OF BEING A LEXUS OWNER GO FAR BEYOND THE INTRINSIC PLEASURE OF DRIVING THE VEHICLE. FROM THE MOMENT YOU'RE HANDED THE KEYS, YOU'LL ALSO BE WELCOMED TO THE LEXUS ENCORE PRIVILEGES PROGRAMME† - OFFERING A RANGE OF EXCLUSIVE INITIATIVES THAT REAFFIRM OUR ONGOING PURSUIT OF PERFECTION.

It all means you'll enter a world of benefits that extends to every corner of life. A world where everything's just that much easier and works that much more seamlessly. And a world where, should trouble ever find you, you can always find a helping hand.

Take our After Sales Service as an example. Both our technology and our technicians are at the forefront of automotive innovation. And our profound understanding of every single component of your Lexus means we can do more to ensure it's a pleasure to drive today, and in the long run. It's a world you've always belonged in. A privilege unique to Lexus drivers.

Silver service

Every aspect of your Lexus is built around your comfort and convenience, so it's fitting that when it's ready for a service, we'll come and pick it up from you and provide you with a complimentary loan car while we're inspecting. Plus, when we return your Lexus, it will have received a complimentary wash and interior vacuum.

Experience Lexus outside your vehicle

We're constantly striving to enhance the Lexus ownership experience. It's what we're known for. Our luxury events will be the perfect way to experience the Lexus lifestyle and network with other owners. Tickets may be limited, so be quick to secure your place.

Peace of mind

Wherever you are and whatever you're doing, you can relax, because with our Encore Privileges Programme, you have the 24-hour support of Lexus DriveCare.* We'll look after your car and, just as importantly, we'll look after you and your passengers.

Well read

You can stay abreast of all things Lexus from the comfort of your own home, with our Lexus Magazine delivered right to your door. It'll keep you updated on all aspects of luxury living and covers everything you need to know about the cars that are leading the world.

See lexus.com.au/services/benefits for details.

† Terms and Conditions apply.

* Full DriveCare details and conditions are available in your Lexus DriveCare wallet or you can phone 1800 253 987. Lexus Australia reserves the right to change, without notice, any benefits specified. Benefits should be confirmed at the time of ordering with your authorised Lexus dealer. To the extent permitted by law, Lexus Australia will not be liable for any damage, loss or expense incurred in relation to the benefits specified above (whether by way of negligence or otherwise). Lexus Australia, a division of Toyota Motor Corporation Australia Limited ABN 64 009 686 097, 155 Bertie St, Port Melbourne Vic 3207.



New Vehicle Warranty expires four years from date of first delivery or 100,000kms, whichever occurs first. Refer to the Warranty conditions. The New Vehicle Warranty does not limit and may not necessarily exceed your rights under the Competition and Consumer Act 2010.

The HV (Hybrid) Battery Warranty expires eight years from date of first delivery or 160,000kms, whichever occurs first. The Warranty is comprised of the four year Lexus New Vehicle Warranty and an additional four year Lexus Australia Hybrid (HV) Battery Warranty. Refer to the Warranty conditions. The Warranty does not limit and may not necessarily exceed your rights under the Competition and Consumer Act 2010.

- (1) Wireless Charger is available on F Sport and Sports Luxury grades only. Only Qi-supported devices are compatible. Refer to your device manufacturer to determine your device's compatibility. Some devices purchased may require the purchase of a Qi-supported accessory to enable wireless charging.
- (2) Lexus Enform is free for the duration of your new car warranty. Contact your Lexus dealer for details. Visit lexus.com.au/enform for more information. Enform services rely on data from the driver's compatible mobile phone and information provided by third parties. Availability is dependent on a number of factors, including the availability of third-party information, mobile service, sufficient mobile data allowance and GPS satellite signal reception. Mobile usage is at the user's cost.
- (3) Digital radio station coverage dependent on vehicle location.
- (4) Panoramic View Monitor and Lane Departure Warning are driver assist devices only and should not be used as a substitute for safe driving practices. The area into which the vehicle is driven must be visually monitored by the driver.
- (5) Automatic High Beam is a driver assist device only and should not be used as a substitute for safe driving practices.
- (6) Blind Spot Monitor with Rear Cross Traffic Alert system is a driver assist device only and should not be used as a substitute for safe driving practices. The area into which the vehicle is driven must be visually monitored by the driver.
- (7) Rear View Camera and Rear Parking Sensors are driver assist devices only and should not be used as a substitute for safe driving practices. The area into which the vehicle is driven must be visually monitored by the driver.
- (8) Current navigation mapping database encompasses major capital and primary national road networks and offers some coverage in regional areas.
- (9) Hill Start Assist Control (HAC), Vehicle Stability Control (VSC) and Traction Control (TRC) are driver assist devices only and should not be used as a substitute for safe driving practices. The area into which the vehicle is driven must be visually monitored by the driver.
- (10) Pre-Collision Safety System (PCS) and All Speed Radar Active Cruise Control (ACC) are driver assist technology and should not be used as a substitute for safe driving practices. Driver should continue to monitor the road.
- (11) The Bluetooth® word mark is owned by Bluetooth SIG, Inc. Not all devices are compatible and functionality varies depending on the device.
- (12) iPod® and iPhone® are trademarks of Apple Inc. Not all devices will be compatible and functionality will vary depending on the device.
- (13) Emissions vary depending on driving conditions/style, vehicle conditions and options/accessories.
- (14) Kerb, tare and payload weights are nominal and will vary depending on options and accessories.
- (15) Gross Vehicle Mass (GVM) is the total permissible combined weight of the vehicle, including occupants, fuel and cargo.
- (16) Self-restoring paint contains an outer coating with elastic qualities capable of restoring superficial scratches only.
- (17) Some vehicle dimension figures are approximate and vary due to options and accessory fitment.
- (18) Fuel consumption varies depending on driving conditions/style, vehicle conditions and options/accessories. Source of fuel consumption data: ADR81/02 combined (L/100km) for auto models.

IMPORTANT NOTICE – please read: Lexus Australia uses its best endeavours to ensure this material is correct when published. You must check with your authorised Lexus dealer when ordering to ensure the vehicle with your chosen specifications, equipment and colour is available and that the vehicle can be delivered within the timeframe suitable to you. When ordering accessories, you must check with your authorised Lexus dealer to ensure the accessory's design, features and colours are available and will fit your vehicle. Please also consider the mass of your load to ensure you will not exceed the maximum allowable individual axle capacity, Gross Vehicle Mass and/or Gross Combined Mass of the vehicle. Refer to lexus.com.au for further details. Colours displayed here are a guide only and may vary from actual colours due to printing/display processes. Certain accessories when fitted will require the removal of standard equipment. Standard equipment may be retained by Lexus Australia. Lexus Australia reserves the right to change, without notice, at any time prices, colours, materials, equipment, specifications and discontinue colours/models. To the extent permitted by law, Lexus Australia will not be liable for any damage, loss or expense incurred as a result of reliance on this material in any way. Distributed nationally by Lexus Australia ABN 64 009 686 097, 155 Bertie St, Port Melbourne Vic 3207. PROOF HQ: L2015-000315. PRINTED: November 2015. LEX0325.



THIS BOOK IS PRINTED ON GREEN PAPER

The Lexus book you are reading has been produced using HannoArt Satin. A premium coated paper representing a level of craftsmanship that is without peer. This environmentally responsible paper is manufactured using low environmental impact FSC® certified pulp and is certified carbon neutral by The Carbon Reduction Institute. Sappi, the manufacturers of HannoArt, place high importance on delivering an environmental and sustainable operation. They operate under world's best practice ISO 14001 EMS and EMAS certification and eliminate harmful by-products by using Totally Chlorine Free (TCF) pulp. HannoArt is archival, so like our vehicles it's made to stand the test of time.

As a company that strives to lessen its impact on the environment in every way possible, Lexus believes that choosing our paper wisely is one more step we can take in preserving our planet.

^Calculations encompass carbon emissions from seedling to printer. For full details please visit kwdoggett.com.au
To learn more about the NX Line contact your Lexus Dealer on 1800 023 009 or visit lexus.com.au



