

Subject: ROUGH IDLE, LACK OF POWER, AND/OR MIL ON WITH DTC P2177/P2187 (FUEL SYSTEM LEAN)	Bulletin No: 01-022/08
	Last Issued: 04/02/2008

BULLETIN NOTE

This bulletin supersedes the previous bulletin issued on 03/27/08. The REPAIR PROCEDURE has been revised.

APPLICABLE MODEL(S)/VINS

2007-2008 Mazdaspeed3 vehicles with VINs lower than JM1BK**** ** 859606 (produced before November 22, 2007)

2006-2007 Mazdaspeed6 vehicles

2007-2008 CX-7 vehicles with VINs lower than JM3ER**** ** 196510 (produced before November 19, 2007)

DESCRIPTION

Due to low fuel pressure at the high-pressure fuel pump, some vehicles may experience the following:

- Rough idle, stall, and/or hesitation under cold conditions.
- Intermittent lack of power during acceleration when the engine gets hot.
- MIL turns on with DTC P2177/P2187 (fuel system too lean at off idle).

This is caused by a delayed fuel pressure build-up from the high pressure fuel pump. There are two main reasons for this:

1. The drive current from the PCM is not enough for some fuel pumps.
2. Some fuel pumps have slower response.

To fix the problem, the PCM software and the specification of the high-pressure fuel pump have been changed. Customers having this concern should have their vehicle repaired using the following repair procedure.

REPAIR PROCEDURE

1. Reboot the IDS to clear memory before reprogramming.
2. Using IDS 51.9 or later software, reprogram the PCM to the latest calibration (refer to "Calibration Information" table) by following the "Module Reprogramming" procedure.

NOTE:

- Always update the IDS tool first, then follow on-screen instructions to download the needed calibration file for PCM reprogramming.
- It is not necessary to remove any fuses or relays during PCM reprogramming when the IDS screen prompts you to do so. You may accidentally stop power to one of the PCM terminals and cause the PCM to be blanked, or you may receive error messages during the IDS reprogramming procedure.

- IDS shows the calibration part numbers after programming the PCM.
 - Please be aware that PCM calibration part numbers and file names listed in any Service Bulletin may change due to future releases of IDS software, and additional revisions made to those calibrations for service related concerns.
 - When reprogramming a PCM, IDS will always display the “latest” calibration P/N available for that vehicle. If any calibration has been revised/updated to contain new information for a new service concern/issue, it will also contain all previously released calibrations.
 - **When performing this procedure, we recommend that a battery charger be installed on the vehicle battery and turned ON to a maximum charge of no more than 20 AMPS to keep the vehicle battery up to capacity. If you exceed 20 AMPS, it could damage the VCM.**
3. For vehicles built before April 7, 2007 that are experiencing the conditions as noted in this service bulletin after the PCM calibration update, perform a Warranty Vehicle Inquiry using your eMDCS System and inspect Warranty Claim Inquiry Detail for high-pressure fuel pump replacement.
- If no prior history of replacement, replace the high-pressure fuel pump. Refer to MS3 online instructions or Workshop Manual section 01-14 FUEL PUMP UNIT REMOVAL/INSTALLATION.
 - If the history indicates part number L3K9-13-35ZB was used during a repair, use the following illustration to inspect the production date of the high-pressure fuel pump. Replace it if the production date is before March 26, 2007.

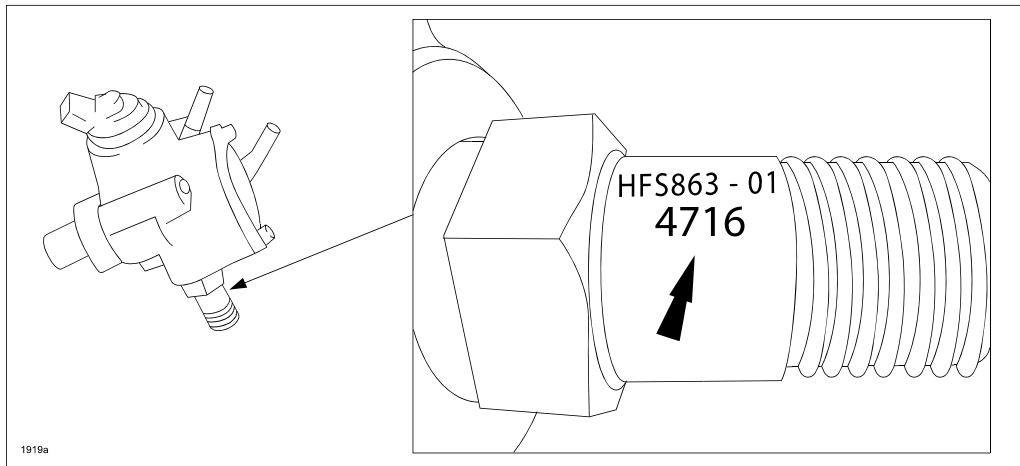

Date of production is marked as a 4 digit code “YMDD” at the pipe.

Y for Year	4 for 2004....7 for 2007
M for Month	1 for Jan....9 for Sept, X for October, Y for Nov, Z for Dec
DD for Date	01 for 1st of month....31 for 31st of month
Example	“4Z16” means Dec 16, 2004; 7608 means June 8, 2007

CAUTION: When replacing the high-pressure fuel pump, it is very important to make sure that the tension collar is present before reinstalling the pump. Failure to do so will result in excessive engine noise and the subsequent failure of the high-pressure fuel pump and its cam lobes.

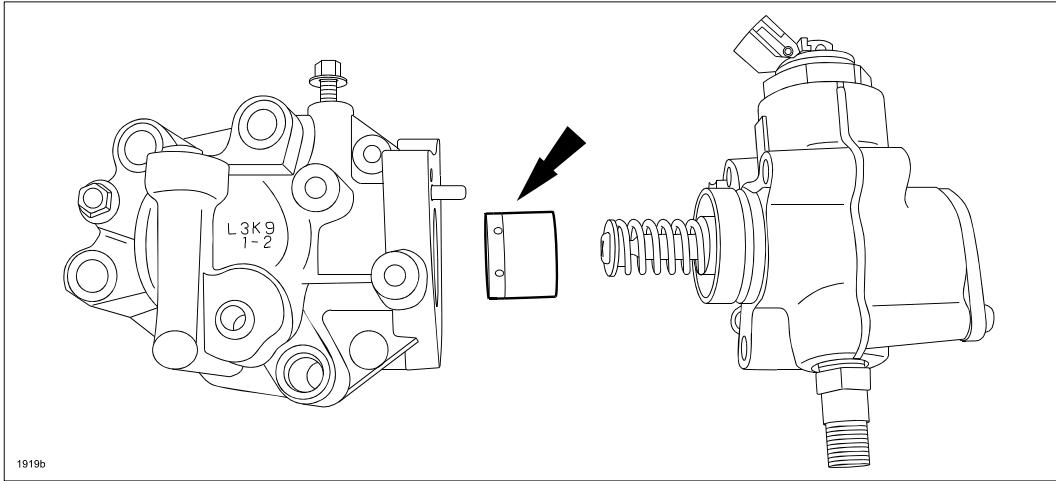

4. After performing the PCM reprogramming procedure, verify the repair by starting the engine and making sure there are no MIL illumination or abnormal warning lights present.

NOTE:

- If any DTCs should remain after performing DTC erase, diagnose the DTCs according to the appropriate Troubleshooting section of the Workshop Manual.
 - After PCM reprogramming, it is no longer necessary to road test the vehicle to “relearn” KAM (Keep Alive Memory).
5. Fill out an “Authorized Modifications” label (P/N 9999-95-AMDC-97) with the new PCM calibration information, your dealer code, and today’s date.

mazda AUTHORIZED MODIFICATIONS
THESE MODIFICATIONS HAVE BEEN APPROVED, AS APPROPRIATE, BY THE EPA AND CARB.
THE FOLLOWING MODIFICATIONS HAVE BEEN MADE:

1326c

6. Place the “Authorized Modifications” label on the “A” pillar below the tear tag in the driver door jamb.

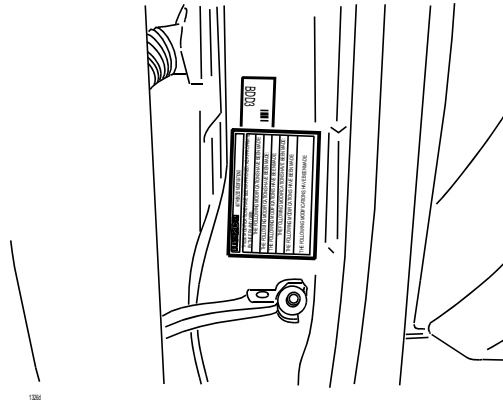

CALIBRATION INFORMATION

Mazdaspeed3 (52.2 or later software)

Spec	New PCM Calibration Part Number	File Name
CA	L39R-18-881D	SW-L39RED000
Fed, Canada	L39S-18-881D	SW-L39SED000

Mazdaspeed6 (51.9, 52.2 or later software)

Spec	New PCM Calibration Part Number	File Name
CA	L38G-18-1881G	SW-L38JEG000
Fed/Canada	L38K-18-1881G	SW-L38KEG000

CX-7 (51.9, 52.2, or later software)

Spec	Model Year	Drive	New PCM Calibration Part Number	File Name
CA	2008	2WD	L39L-18-881D	SW-L39LED000
		4WD	L39M-18-881D	SW-L39MED000
	2007	2WD	L33L-18-881T	SW-L33LET000
		2WD(*)	LKYX-18-881B	SW-LKYXEB000
		4WD	L33M-18-881T	SW-L33MET000
		4WD(*)	LKYZ-18-881B	SW-LKYZEB000
Fed/Canada	2008	2WD	L39N-18-881D	SW-L39NED000
		4WD	L39P-18-881D	SW-L39PED000
	2007	2WD	L33N-18-881T	SW-L33NET000
		2WD(*)	LKZ1-18-881B	SW-LKZ1EB000
		4WD	L33P-18-881T	SW-L33PET000
		4WD(*)	LKZ2-18-881B	SW-LKZ2EB000
Mexico	2007	2WD	L39J-18-881F	SW-L39JEF000
		4WD	L39K-18-881F	SW-L39KEF000

(*): TI-110/07 (Engine Pinging and/or Lack of Power During Acceleration) applied vehicles.

NOTE: The PCM Calibration Part Numbers listed above are provided for PCM reprogramming purposes only. These are not necessarily the same Mazda part numbers used to order an actual PCM through the Mazda Parts System. It is not necessary to order a PCM as part of this repair procedure.

PART(S) INFORMATION

Part Number	Description	Qty.	Note
L3K9-13-35ZC	Pump, Fuel	1	A new part can be used in place of the former part, but the former part cannot be used in place of the new part.

WARRANTY INFORMATION

NOTE:

- This warranty information applies only to verified customer complaints on vehicles eligible for warranty repair. Refer to the Warranty Wizard for warranty term information.
- Additional diagnostic time cannot be claimed for this repair.

	PCM Reprogram Only	PCM Reprogram and Fuel Pump Replacement
Warranty Type	A	A
Symptom Code	08	08
Damage Code	9W	9W
Part Number Main Cause	5555-08-007A	L3K9-13-35ZC
Quantity	0	1
Operation Number / Labor Hours	XXC5RXFX / 0.3 Hrs.	XXC5RXX / 1.7 Hrs. (Mazdaspeed3); 1.2 Hrs. (Mazdaspeed6); 1.4 Hrs. (CX-7)