

SPECIFICATIONS

Powertrain	
Engine type	2.0 litre in-line 4 cylinder 16 valve DOHC S-VT
Engine capacity	1,998 cc
Bore and stroke	87.5 mm x 83.1 mm
Compression ratio	10.8 : 1
Maximum power	man 118 kW @ 7,000 rpm auto 118 kW @ 6,700 rpm
Maximum torque	188 Nm @ 5,000 rpm
Throttle control	Electronic (drive-by-wire)
Fuel system	Electronic port fuel injection
Fuel tank capacity	50 litres
Recommended fuel	Premium unleaded (95RON or higher)
Fuel consumption ¹ (combined)	8.1 litres per 100 km
Manual transmission	6-speed
Activematic (auto) transmission	6-speed
Gear ratio	1st - man/auto 3.709 / 3.538 2nd 2.190 / 2.060 3rd 1.536 / 1.404 4th 1.177 / 1.000 5th 1.000 / 0.713 6th 0.832 / 0.582 reverse 3.603 / 3.168 final drive 3.727 / 4.100

Chassis	
Brake diameter	front 290 mm rear 280 mm
Brake type	front Ventilated disc rear Solid disc
Steering type	Hydraulic power assist steering
Suspension	front Double wishbone rear Multi-link
Turning circle	kerb to kerb 9.4 m
Tyre size	205/45R17
Tyre index	84W
Wheel size	17 x 7.0 J
Wheel type	Alloy

Dimensions	
Ground clearance	laden 118 mm
Overall length	4,020 mm
Overall height	1,255 mm
Overall width	1,720 mm
Track	front 1,490 mm rear 1,495 mm
Wheelbase	2,330 mm

Weights and capacities	
Cargo room	volume (VDA) 150 litres
Kerb weight	man 1,167 - 1,169 kg auto 1,177 - 1,179 kg

Exterior		Roadster Coupe	Roadster Coupe Sports
BBS alloy wheels		-	●
Door handles (body coloured with chrome inserts)		●	●
Exhaust extension (chrome)		●	●
Fog-lamps (front)		●	●
Front and rear bumpers (body coloured)		●	●
Green-tinted windscreen, side and rear windows		●	●
Headlamps (Halogen)		●	●
Metallic/Mica paint		○	○
Power mirrors (body coloured)		●	●
Power-retractable hard-top with rear window (glass) demister		●	●
Power windows		●	●
Suspension strut tower brace bar (front)		●	●

Interior		Roadster Coupe	Roadster Coupe Sports
Air-conditioning		●	●
Critical function warning lights/chimes		●	●
Cruise control		●	●
Cupholders		●	●
Digital clock		●	●
Door bottle holders		●	●
Drilled aluminium pedals and footrest		●	●
Glove box (lockable)		●	●
Instrument panel light dimmer		●	●
Interior illumination:	cargo room lamp	●	●
	dome lamp	●	●
	ignition key surround	●	●
Interior release for:	boot lid	●	●
	fuel filler door	●	●
Leather-wrapped:	gear shift knob	●	●
	handbrake handle	●	●
	steering wheel	●	●
Lights-left-on audible warning		●	●
Low fuel warning light		●	●
Oil pressure gauge		●	●
Puncture repair kit and compressor		●	●
Rear console box (lockable)		●	●
Seat trim:	leather ²	●	-
	leather ² /Alcantara ^{®3}	-	●
Seat type:	sports	●	-
	RECARO	-	●

Interior (continued)		Roadster Coupe	Roadster Coupe Sports
Seats with:	height adjustment (driver)	●	●
	integral head restraints	●	●
	rake and slide adjustment	●	●
Tachometer and electronic odometer/tripmeter		●	●
Tilt adjustable steering wheel		●	●
Vanity mirrors (driver and passenger)		●	●
'Windblocker' aero board		●	●
Wipers (front) 2-speed with intermittent function		●	●

Audio		Roadster Coupe	Roadster Coupe Sports
AM/FM tuner		●	●
Auxiliary input (3.5 mm MP3 player compatible)		●	●
CD player, in-dash 6-disc (MP3 compatible)		●	●
Premium Bose [®] 200 watt amplifier and speakers		●	●
Speakers (7)		●	●
Steering wheel-mounted audio controls		●	●

Safety		Roadster Coupe	Roadster Coupe Sports
Airbags SRS:	front (driver and passenger)	●	●
	side (front)	●	●
Anti-lock Braking System (ABS)		●	●
Crumple zones (front and rear)		●	●
Day/night rear vision mirror		●	●
Dynamic Stability Control (DSC) – switchable on/off		●	●
Engine immobiliser		●	●
High backed bucket seats		●	●
High mount stop lamp		●	●
Left-hand-side convex (wide angle) exterior mirror		●	●
Limited-Slip Differential (LSD), torque-sensing	manual only		manual only
One touch (down only) power window (driver and passenger)		●	●
Remote central locking (2 transmitters with retractable key)		●	●
Seat-belts with pretensioners and load-limiters		●	●
Side impact door beams		●	●
Traction Control System (TCS)		●	●

● Standard Feature - Not Available ○ No Cost Option

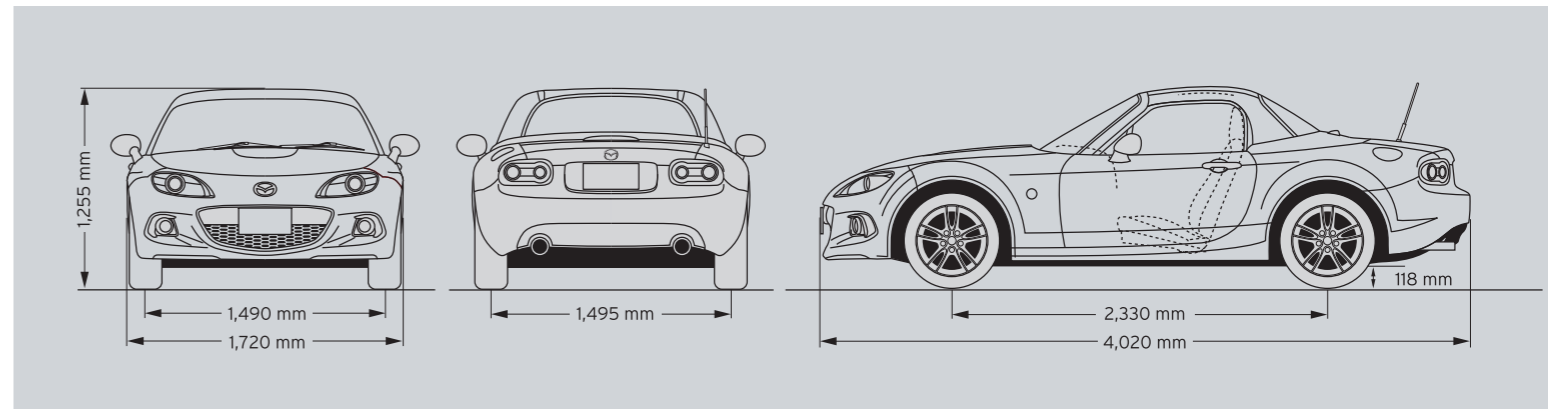

9. SPECIFICATIONS

		MX-5 Roadster Coupe	MX-5 Roadster Coupe Sports
Powertrain			
Engine type		2.0 litre in-line 4-cylinder 16-valve DOHC S-VT	
Engine capacity		1,998 cc	
Bore and stroke		87.5 x 83.1 mm	
Compression ratio		10.8 : 1	
Maximum power	man	118 kW @ 7,000 rpm	
	auto	118 kW @ 6,700 rpm	
Maximum torque		188 Nm @ 5,000 rpm	
Throttle control		Electronic (drive-by-wire)	
Fuel system		Electronic port fuel injection	
Fuel tank capacity		50 litres	
Recommended fuel		Premium unleaded (95 RON or higher)	
Fuel consumption (man & auto)	combined	8.1 litres per 100km	
Manual transmission		6-speed	
Activematic transmission		6-speed	
Gear ratio	1st - man/auto	3.709 / 3.538	
	2nd	2.190 / 2.060	
	3rd	1.536 / 1.404	
	4th	1.177 / 1.000	
	5th	1.000 / 0.713	
	6th	0.832 / 0.582	
	reverse	3.603 / 3.168	
	final drive	3.727 / 4.100	
Chassis			
Brake type	front / rear	Ventilated disc / Solid disc	
Brake diameter	front / rear	290 mm / 280 mm	
Steering type		Hydraulic power assist steering	
Suspension	front	Double wishbone	
	rear	Multi-link	
Turning circle	kerb to kerb	9.4 m	
Tyre size		205/45 R17	
Wheel type / size		Alloy / 17 x 7.0 J	

		MX-5 Roadster Coupe	MX-5 Roadster Coupe Sports
Exterior			
BBS alloy wheels		-	X
Door handles (body coloured with chrome inserts)		X	X
Exhaust extension (chrome)		X	X
Fog-lamps (front)		X	X
Front and rear bumpers (body coloured)		X	X
Green tinted windscreen, side and rear windows		X	X
Headlamps (halogen)		X	X
Metallic/mica paint		No cost option	No cost option
Power mirrors (body coloured)		X	X
Power retractable hard-top with rear window (glass) demister		X	X
Power windows		X	X
Suspension strut tower brace bar (front)		X	X
Interior			
Air-conditioning		X	X
Critical function warning lights/chimes		X	X
Cruise control		X	X
Cupholders		X	X
Digital clock		X	X
Door bottle holders		X	X
Drilled aluminium pedals and footrest		X	X
Glove box (lockable)		X	X
Instrument panel light dimmer		X	X
Interior illumination:	dome lamp	X	X
	cargo room lamp	X	X
	ignition key surround	X	X
Interior release for fuel filler door and boot lid		X	X
Leather-wrapped:	gear shift knob	X	X
	handbrake handle	X	X
	steering wheel	X	X
Lights-left-on audible warning		X	X
Low fuel warning light		X	X
Oil pressure gauge		X	X
Puncture repair kit and compressor		X	X
Rear console box (lockable)		X	X

		MX-5 Roadster Coupe	MX-5 Roadster Coupe Sports
Interior Contd.			
Seat trim:	leather ²	X	-
	leather ² /alcantara ^{*3}	-	X
Seat type:	sports	X	-
	RECARO	-	X
Seats with:	height adjustment (driver)	X	X
	integral head restraints	X	X
	rake and slide adjustment	X	X
Tachometer and electronic odometer/tripmeter		X	X
Tilt adjustable steering wheel		X	X
Vanity mirrors (driver and front passenger)		X	X
'Windblocker' aero board		X	X
Wipers (front) 2-speed with intermittent function		X	X
Audio			
AM/FM tuner		X	X
Auxiliary input (3.5mm MP3 player compatible)		X	X
CD player, in-dash 6-disc (MP3 compatible)		X	X
Premium Bose® 200 watt amplifier and speakers		X	X
Speakers (7)		X	X
Steering wheel mounted audio controls		X	X

		MX-5 Roadster Coupe	MX-5 Roadster Coupe Sports
Safety			
Airbags SRS:	Front (driver & passenger)	X	X
	Side (front)	X	X
Anti-lock Braking System (ABS)		X	X
Crumple zones (front and rear)		X	X
Day/night rear vision mirror		X	X
Dynamic Stability Control (DSC) - switchable on/off		X	X
Engine immobiliser		X	X
High backed bucket seats		X	X
High mount stop lamp		X	X
Left-hand-side convex (wide angle) exterior mirror		X	X
Limited-Slip Differential (LSD) torque-sensing		manual only	manual only
One touch (down only) power window (driver and passenger)		X	X
Remote central locking (2 transmitters with retractable key)		X	X
Seat-belts with pretensioners and load-limiters		X	X
Side impact door beams		X	X
Traction Control System (TCS)		X	X
Dimensions			
Ground clearance	laden	118 mm	
Overall height		1,255 mm	
Overall length		4,020 mm	
Overall width		1,720 mm	
Track	front	1,490 mm	
	rear	1,495 mm	
Wheelbase		2,330 mm	
Cargo room	volume (VDA)	150 litres	
Kerb weight	man	1,167 kg	1,169 kg
	auto	1,177 kg	1,179 kg