

SPECIFICATIONS

Neo

Maxx

Genki

Powertrain

Engine type	1.5 litre in-line 4 cylinder 16 valve DOHC S-VT		
Engine capacity	1,498 cc		
Bore and stroke	78.0 mm x 78.4 mm		
Compression ratio	10.0 : 1		
Maximum power	76 kW @ 6,000 rpm		
Maximum torque	135 Nm @ 4,000 rpm		
Throttle control	Electronic (drive-by-wire)		
Fuel system	Electronic fuel injection		
Fuel tank capacity	42 litres		
Recommended fuel	Unleaded (91RON or higher) or E10		
Fuel consumption ¹	man (combined)	6.4 litres per 100 km	
	auto (combined)	6.8 litres per 100 km	
Emission standard	Euro stage IV		
Manual transmission	5-speed		
Automatic transmission	4-speed		
Gear ratio	1st - man / auto	3.416 / 2.816	
	2nd	1.842 / 1.553	
	3rd	1.290 / 1.000	
	4th	0.972 / 0.695	
	5th	0.775 / -	
	reverse	3.214 / 2.279	
	final drive	4.105 / 4.147	

Chassis

Brake type	front	Ventilated disc		
	rear	Drum		
Steering type	Electric power assist steering			
Steering wheel turns lock to lock	2.7			
Suspension	front	MacPherson strut		
	rear	Torsion beam		
Turning circle	kerb to kerb	9.8 m		
Tyre size		185/55R15 82V	185/55R15 82V	195/45R16 80W
Wheel size		15 x 6.0 J	15 x 6.0 J	16 x 6.5 J
Wheel type		Steel	Alloy	Alloy
Wheel type (spare)			Temporary	

Weights and capacities

Cargo room	volume (VDA)	250 litres	250 litres	250 litres
	volume (VDA) ²	469 litres	469 litres	469 litres
Kerb weight man	man	1,010 kg	1,010 kg	1,016 kg
	auto	1,032 kg	1,032 kg	1,038 kg
Towing capacity ³	braked	700 kg	700 kg	700 kg
	unbraked	500 kg	500 kg	500 kg

Neo

Maxx

Genki

Dimensions

Ground clearance	laden	119 mm	119 mm	119 mm
Overall height		1,475 mm	1,475 mm	1,475 mm
Overall length		3,900 mm	3,900 mm	3,900 mm
Overall width		1,695 mm	1,695 mm	1,695 mm
Track	front	1,475 mm	1,475 mm	1,465 mm
	rear	1,465 mm	1,465 mm	1,455 mm
Wheelbase		2,490 mm	2,490 mm	2,490 mm

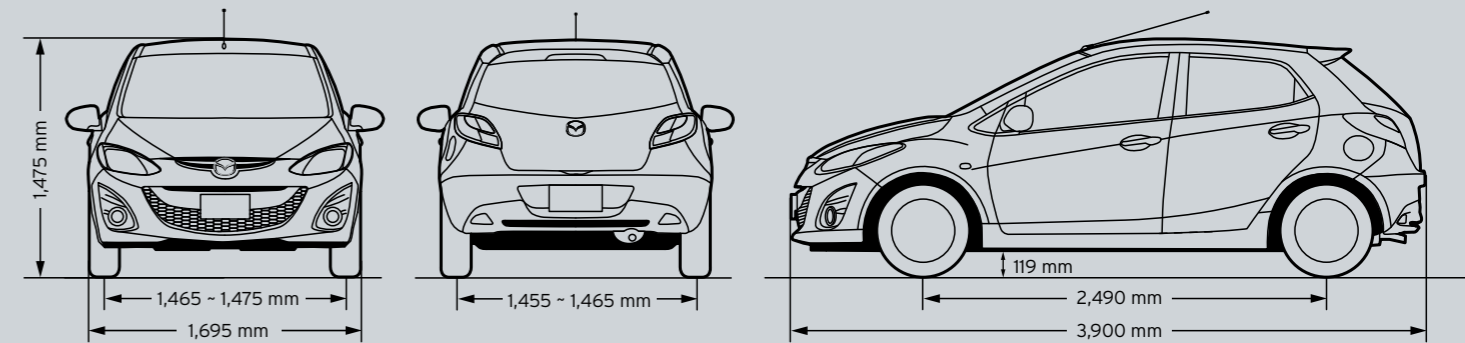

MAXX IN AQUATIC BLUE MICA

SPECIFICATIONS

Neo

Maxx

Genki

Exterior

	Neo	Maxx	Genki
Door handles (body coloured)	●	●	●
Exhaust extension (chrome)	-	-	●
Fog-lamps (front)	-	-	●
Front and rear bumpers (body coloured)	●	●	●
Green-tinted windscreen, side and rear windows	●	●	●
Headlamps (Halogen)	●	●	●
Metallic/Mica paint	●	●	●
Mudflaps (front and rear)	●	●	-
Power mirrors and windows	●	●	●
Rear spoiler	-	●	●
Side skirts	-	-	●

Interior

	Neo	Maxx	Genki
12 volt power outlet	●	●	●
Air-conditioning	●	●	-
Air-conditioning (climate control)	-	-	●
Ambient temperature display	-	-	●
Cruise control	●	●	●
Cupholders	●	●	●
Digital clock	●	●	●
Door ajar warning light	●	●	●
Door map pockets (front)	●	●	●
Driver's left footrest	●	●	●
Glove box with magazine rack	●	●	●
Headlamps auto on/off function	-	-	●
Illuminated entry system with delayed fade	●	●	●
Instrument panel light dimmer	●	●	●
Interior illumination:			
cargo room lamp	●	●	●
dome lamp	●	●	●
Interior release for fuel filler door	●	●	●
Leather-wrapped:			
manual gear shift knob	-	-	●
steering wheel	-	-	●
Lights-left-on audible warning	●	●	●
Low fuel warning light	●	●	●
Passenger assist grip (front)	●	●	●
Rear console tray	●	●	●
Seat trim:			
cloth	●	●	●
Seats (front) with:			
adjustable head restraints	●	●	●
height adjustment (driver)	●	●	●
rake and slide adjustment	●	●	●
Seats (rear) with:			
60/40 split-fold backrest	●	●	●
adjustable head restraints	●	●	●

Neo

Maxx

Genki

Interior (continued)

	Neo	Maxx	Genki
Tachometer and electronic odometer/tripmeter	●	●	●
Trip computer (current and average fuel consumption, distance to empty and average vehicle speed)	-	-	●
Vanity mirrors (front)	●	●	●
Ventilation pollen filter	●	●	●
Window demister (rear)	●	●	●
Wipers (front) 2-speed with intermittent function	●	●	-
Wipers (front) 2-speed with rain-sensing function	-	-	●
Wiper (rear) with intermittent function	●	●	●

Audio

	Neo	Maxx	Genki
AM/FM tuner	●	●	●
Auxiliary input (3.5 mm MP3 player compatible)	●	●	●
CD player, single disc (MP3 compatible)	●	●	●
Speakers (4)	●	●	●
Steering wheel-mounted audio controls	●	●	●

Safety

	Neo	Maxx	Genki
Airbags SRS:			
front (driver and passenger), side (front), curtain (front and rear)	●	●	●
Anti-lock Braking System (ABS)	●	●	●
Child restraint anchor points and childproof rear door locks	●	●	●
Collapsible steering column	●	●	●
Dynamic Stability Control (DSC) - switchable on/off	●	●	●
Electronic Brake-force Distribution (EBD)	●	●	●
Emergency Brake Assist (EBA)	●	●	●
Engine immobiliser	●	●	●
High mount stop lamp	●	●	●
Intrusion-minimising brake pedal	●	●	●
Left-hand-side convex (wide angle) exterior mirror	●	●	●
One touch (up and down) power window (driver)	●	●	●
Remote central locking (one transmitter with retractable key)	●	●	●
Seat-belt warning audible and visual (front)	●	●	●
Seat-belts 3-point lap-sash (all seats)	●	●	●
Seat-belts (front) with pretensioners, load-limiters and height adjustable shoulder anchorages	●	●	●
Side impact door beams	●	●	●
Traction Control System (TCS)	●	●	●
'Triple H' safety construction with front and rear crumple zones	●	●	●
Whiplash-minimising front seats	●	●	●