



M-Class

Mercedes-Benz

“Our philosophy is very simple.
We give our best for people who expect the best.”

Dr Dieter Zetsche

Contents

The M-Class	4	My M-Class	50
Exterior design	8	Equipment	52
Agility	16	Sports packages	52
Efficiency	16	Audio and communication systems	54
Diesel engines	18	Standard equipment	58
Petrol engines	20	Optional extras	60
Transmission	22	Equipment packages	62
Suspension	24	Light-alloy wheels	64
Comfort	26	Genuine accessories	66
Interior	26	designo	68
Flexibility	32	Colours and materials	72
Off-road performance	34	Paint finishes	72
Safety	38	Upholstery and trim elements	74
Active safety	38	Combination options	76
Passive safety	40	Technical data	78
AMG	42	Services	82
ML 63 AMG	42		
AMG optional extras	46		

When you feel like a change from the highway, it'll let you go your own way

Whether you're cruising on bustling city streets or have a rocky trail ahead of you: with the M-Class you can enjoy effortlessly superior driving performance. Whatever the surface, be it smooth or rough, paved or not.

The M-Class has looks to match its impressive off-road capability: its particularly exclusive and dynamic exterior is complemented perfectly by the design of the interior. Fine materials and exceptional workmanship, advanced technology – as practical as it is good-looking – and inviting seats set the tone inside.

The M-Class demonstrates versatility at a very high level – and we're not just talking about ground clearance.

The M-Class





Take the long way home





A civilised answer to the call of the wild

Taking up challenges can be so exhilarating. Especially if you tackle them with the M-Class.

The front end, with a radiator grille featuring black louvres and chrome highlights, immediately signals determination. Equally striking are the exterior mirrors and the silver-coloured simulated underguard. The front apron with its

impressive visual width and integral fog lamps complements the transition to the headlamps to underline the muscular character of the M-Class.

In fact, its looks alone are enough to inspire you to give in to your curiosity and indulge your spirit of adventure.





Style and substance in perfect harmony

Muscular wings and protective sidebars dominate the side view of the M-Class. They form the basis of the dynamic silhouette with its flowing front-to-rear lines and the characteristic slope of the C-pillar, while the standard-fit roof rails signify the vehicle's versatility. The appearance of the M-Class is enhanced to great effect by the powerful look of the standard 17 or 19-inch wheels (ML 63 AMG has 20-inch wheels). As you can see, the M-Class is an extremely good-looking vehicle. But that's only part of the story. You will find that its true character is revealed not at first glance, but on the first drive.





Yet another stunning view
(and the scenery's not bad either)





Some trips you just remember. Others are unforgettable

From the moment you start the engine to the time you set the parking brake at your destination, there is one M-Class attribute that will stand out: excitement. The very look of the vehicle promises flexibility, dynamism and exclusivity, from the front end through the characteristic wedge-like line of the side to the rear end. The panoramic rear window, which extends into the sides of the vehicle, and the discreet spoiler lip seem almost weightless. Dark-tinted tail lights add a distinctly sporty touch. And if you wish, your M-Class can shine even more brightly

when viewed from the rear: with optional LED tail lights.

The reflectors in the rear bumper, which is painted in the vehicle colour, make for improved visibility. But before dark, it's more likely to be the twin exhaust system with oval tailpipes – or square tailpipes as part of the Sports package – that catches the eye. Its design brings to mind a sports car – as will the sense of exhilaration you feel after driving the M-Class.





ML 350



BLUETEC

S ON4609

Innovations for efficient mobility

Climate change is one of the major challenges of the 21st century. The rising consumption of natural resources is having an increasing impact on our planet. As the inventor of the motor car, Mercedes-Benz has a special responsibility to implement innovative technologies in order to develop solutions which help preserve the environment and ensure that raw materials are used as efficiently as possible – without compromising on comfort, safety or driving enjoyment.

Our aim is zero-emission mobility. To help us achieve this, we have developed a range of concepts such as the **BlueEFFICIENCY** technologies. These custom-designed efficiency packages can cut fuel consumption by up to 12%. Each model features a raft of bespoke aerodynamic and energy-management measures with the goal of maximising savings across the board. These measures include tyres with low rolling resistance, lightweight materials, an aerodynamic body shape and the ECO start/stop function available for selected models. For its diesel models,

Mercedes-Benz has brought to market its **BlueTEC** technology. Based on common-rail direct injection (CDI), it is synonymous with the world's cleanest diesel engines as it not only reduces particulate emissions by over 95 percent but can also cut nitrogen-oxide emissions. **HYBRID technology** – a combination of an extremely efficient internal combustion engine and an electric motor – is also highly promising. Vehicles equipped with this drive system set new standards for cleanliness and cost-effectiveness, as demonstrated so strikingly by the S-Class. **BlueTEC HYBRID** is the name Mercedes-Benz gives to the combination of



BlueTEC. The world's cleanest diesel. The M, R and GL-Class will also be available with BlueTEC from autumn 2009

sophisticated hybrid and diesel technology. It allows us to marry the benefits of a hybrid-driven car with those of BlueTEC technology: intelligent energy-management measures and low emissions. Mercedes-Benz also sees great potential in the research being conducted in the field of electric drive systems offering everyday practicality on the basis of high-voltage lithium-ion batteries. As part of its **Concept BlueZERO**, which is close to production maturity, Mercedes-Benz has unveiled three drive configurations based on a common vehicle architecture: battery-electric drive, battery-electric drive plus internal



BlueEFFICIENCY technologies. Diverse models, different approaches, one aim: maximum efficiency

combustion engine for on-board power generation and fuel-cell drive. The latter is due to enter small-scale production as the B-Class **F-CELL** in 2010.

However, there is more to our extensive efficiency concepts than just new drive technologies. Under the banner **Design for Environment** we look at the vehicle's entire lifecycle – from planning to recycling. The same applies to the building and running of new plants. We save energy, avoid pollutants and open up new fields of application for the use of renewable raw materials in the automotive industry. Incidentally, Mercedes-Benz

is the world's only car brand to have received the independently awarded German Technical Inspection Authority¹ environmental certificate. The Daimler Group and its employees also play an active role in supporting comprehensive environmental protection measures, both inside and outside the company's plants. In addition to this, Mercedes-Benz is involved in the development of second-generation alternative fuels (BTL/Biomass-to-Liquid fuels), such as SunDiesel[®], which do not compete with food production. Another aspect is the research discipline of bionics, which looks at structures

and designs in the natural world in order to optimise the weight and aerodynamics of vehicle bodies, for example. And, of course, you can also play your part in reducing the burden on the environment by adjusting your driving style.



HYBRID technology. In the S-Class from summer 2009, it will result in one of the world's most economical luxury cars



Concept BlueZERO. Three approaches to the future of zero-emission vehicles offering everyday practicality



F-CELL. Emission-free mobility with the drive system of the future: the B-Class F-CELL goes into production in 2010

¹ TÜV SÜD Management Service GmbH, Munich

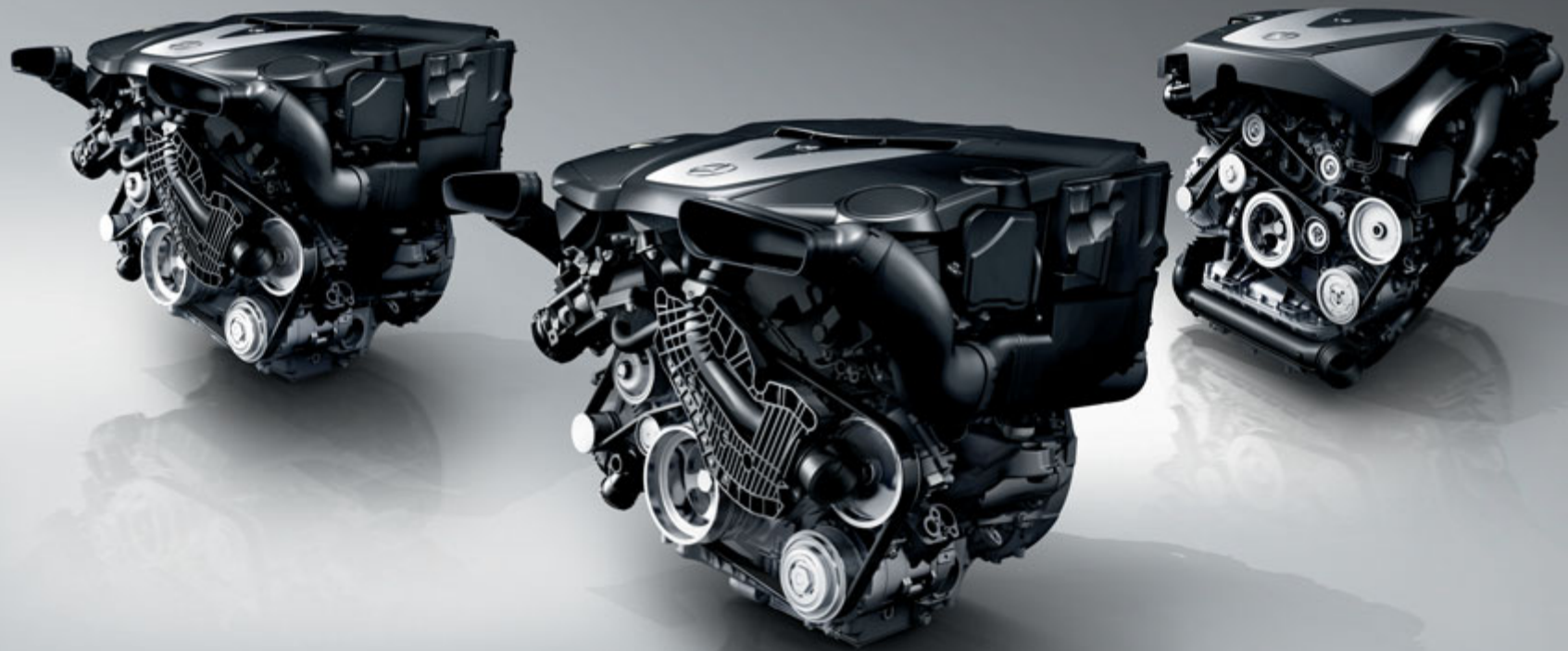

Common rail – to get the most out of fuel

The leading diesel technology

Anyone who enjoys exploring the great outdoors knows how important it is to respect the environment. This mindset is also reflected by the M-Class. Its diesel engines, which are equipped as standard with a particulate filter, are designed to run quietly and offer good fuel efficiency which results in low emissions. Yet they are also decidedly powerful: the ML 300 CDI BlueEFFICIENCY develops 140 kW (190 hp) and a maximum torque of 440 Nm.

The ML 350 BlueTEC gives you an output of 155 kW (211 hp) and a maximum torque of 540 Nm while the ML 450 CDI is powered by an efficient V8 developing 225 kW (306 hp) and up to 700 Nm of torque.

The diesel engines are particularly economical thanks to their optimised common-rail technology. This means that, when the engine is running,

the necessary injection pressure is always available in a central fuel line. It is stored there and put to work as required by individually controlled valves. There isn't a great deal to see, but you notice it in the engine's smooth running characteristics, at the filling station, and – in the long term – in the environment.

ML 300 CDI BlueEFFICIENCY

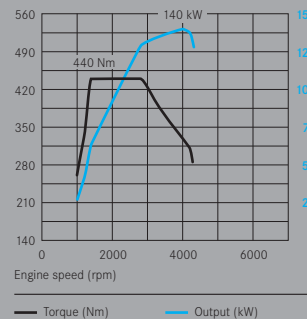

ML 350 BlueTEC

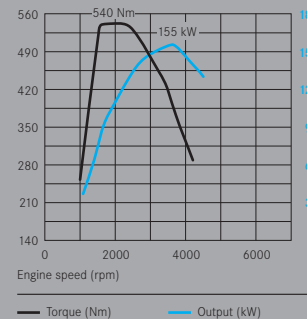

ML 450 CDI

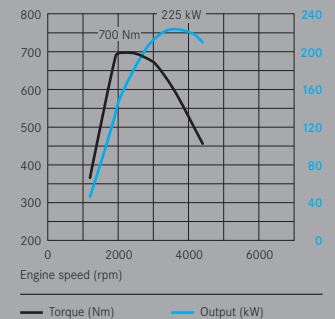

The power to inspire you

The dynamically responsive petrol engines

These engines have the power to set more in motion than just the M-Class. You, too, will be moved by their smooth running characteristics.

The petrol engines are particularly powerful, yet they consume less fuel than most other vehicles of this class.

The 6-cylinder unit in the ML 350 is distinguished by its refinement. With 200 kW (272 hp) at 6000 rpm and a torque of 350 Nm available between 2400 and 5000 rpm, it will take you from 0 to 100 km/h in 8.4 seconds.

High torque and the typical V8 sound characterise the powerful 8-cylinder ML 500. With 285 kW (388 hp) at 6000 rpm and a maximum torque of 530 Nm, available between 2800 and 4800 rpm, it can sprint from 0 to 100 km/h in only 5.8 seconds.

Before you even move off, the sound of the AMG 8-cylinder engine hints at the excitement to come. Once you're on the move, the sense of anticipation gives way to sheer enthusiasm thanks to the output of 375 kW (510 hp) and the formidable torque of 630 Nm at 5200 rpm.

With the power reserves of the 6 or 8-cylinder you're perfectly placed to cover any distance – or to cope with a climb of several dozen metres up a dirt track, for instance.

ML 350

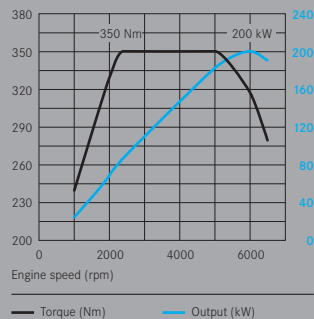

ML 500

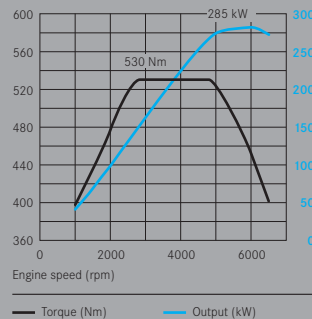

ML 63 AMG

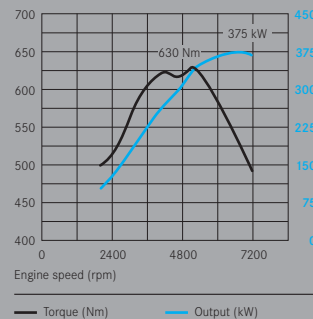



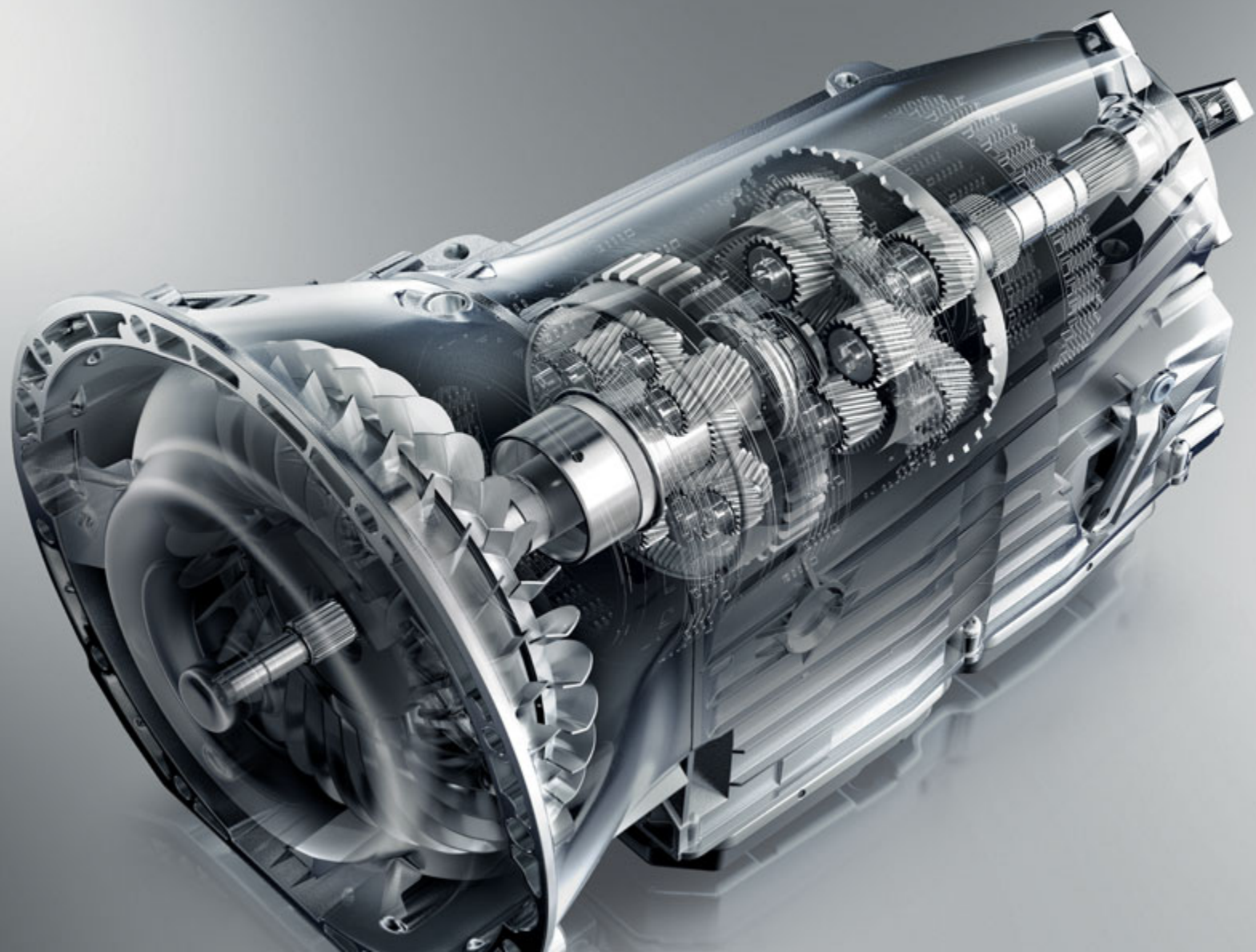

A strong transmission for strong acceleration

The 7G-TRONIC with multiple downshift functionality

To make full use of its power, an engine needs a highly responsive transmission. When the two work together as well as they do in the M-Class, the result is the height of driving refinement. On the road and off it.

Crucial to this interaction is the enhanced 7G-TRONIC automatic transmission. It selects

gears directly and very briskly, ensuring greater pulling power and optimum acceleration.

The 7G-TRONIC automatic transmission has seven gear ratios. As the differences in engine speed between the individual ratios are very small, both driving dynamics and ride comfort are enhanced. Gearshifts are virtually imperceptible, shift times

are unbelievably short, and noise is minimal. Even when shifting down, the 7G-TRONIC automatic transmission affords greater refinement thanks to the multiple downshift function that skips individual gears if required. As a result, it brings you closer than ever to the perfect driving experience. But then, that's what you would automatically expect from a Mercedes-Benz.

Responsive technology

Sensitive to changing surfaces: 4MATIC, 4ETS and AIRMATIC air suspension

Ice and snow, leaves and mud, grass and loose chippings – the surfaces may change, but ride comfort and driving safety are constant factors. This is due principally to the fact that the M-Class has exceptional traction at all times thanks to the interplay of the 4MATIC permanent all-wheel drive, the 4ETS Electronic Traction System, and the AIRMATIC air suspension, including the Adaptive Damping System ADS. 4MATIC

transfers driving power evenly to the axles and wheels. Instead of differential locks, it uses the Electronic Traction System to do this. If a wheel begins to spin, 4ETS brakes it. Unused drive torque is distributed to the other wheels. The result: optimum traction and high ride quality. The AIRMATIC package is standard in the ML 500, ML 450 CDI and ML 63 AMG and optional in the other models. The sensors of the Adaptive

Damping System ADS monitor the driving situation along with the air suspension response and automatically adjust the latter accordingly. But you can also choose manually between sporty and comfort-oriented damper settings. Finally, you can prime all the electronic systems for off-road driving simply by pressing the standard-fit off-road switch. So now you'll find routes opening up to you where previously there were none.

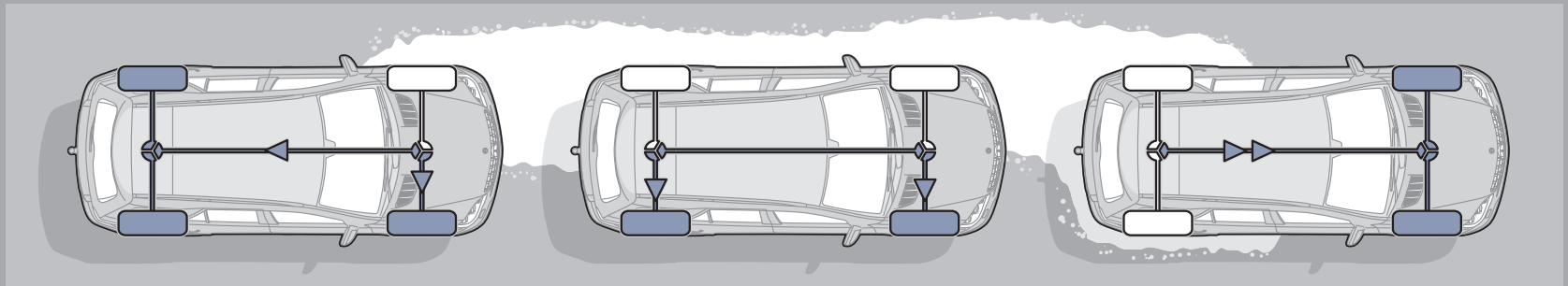

4ETS automatically transfers the drive to the wheels with most grip







The M-Class lets you enjoy some very special places. Starting with its own interior

The interior - as practical as it is luxurious

What is it about some places that gives people a profound sense of well-being? For us, it's simply the feeling you get that everything is exactly as it should be - the cockpit of the M-Class being a case in point.

Intuition is practically all you need to operate many of the electronic functions. The particularly ergonomic arrangement of all the displays and controls is the key. And to keep you from searching too long to find your way, the range of options includes the COMAND APS multimedia system with hard disc navigation, which is available in place of the standard Audio 20 audio

system. Comfortably installed in the ergonomically designed and electrically adjustable seats, you'll find that even a long journey will seem remarkably short. Customers seeking even greater luxury can specify the M-Class with climatized multicontour seats which include a memory package allowing three stored configurations to be recalled at the push of a button.

So you can just get into the M-Class and let the vehicle's systems and ergonomic design take the effort out of searching for everything from your favourite radio station to the ideal seating position.

Even in the big city you're surrounded by nature

Style aplenty, but nothing superfluous: the cockpit

Sometimes you feel at home even though you still haven't reached it. In the interior of the M-Class, for example. Open the door and it receives you with elegant, sporty design, warm colours, and a welcoming ambience.

The first thing that catches your eye is the standard multifunction leather steering wheel with chrome highlights and gearshift paddles.

For those seeking even greater exclusivity, a wood/leather multifunction steering wheel in anthracite poplar or burr walnut is also available. The door centre panels are covered with high-grade ARTICO man-made leather, which is particularly easy to care for. This can also be specified for the dashboard (nappa leather in the ML 63 AMG), over which you have a commanding view of the road thanks to the

combined effect of the raised seat position and the large, sharply raked windscreen with slender A-pillars.

You can take the natural look and feel even further with our range of optional leather upholstery in various colours. Contrasting cashmere beige/black, for example, gives the interior design a particularly distinctive touch.





Made for long journeys and long legs

Plenty of space and a high level of comfort for the rear passengers

Legroom and headroom to spare: the spaciousness afforded by the rear passenger compartment of the M-Class makes long journeys a pleasure, even for tall passengers.

The rear seats are ergonomically shaped, promote a healthy posture and provide good support, not least when cornering. The raised seat position also contributes to the high level of passenger comfort. The clear view to the exterior from the back seats helps to banish boredom on long

trips, especially in conjunction with the optional Rear Seat Entertainment System. This includes: 8-inch screens on the head restraints and two wireless headphones. A games console and TV receiver can be hooked up by means of an Aux-in socket.

As you can see, the three rear seats of the M-Class leave nothing to be desired. Except perhaps the chance of a turn at the steering wheel.



Volume control

Like business class for luggage: the load compartment

It's good to know that the M-Class lets you take along just about anything you care to. The stowage facilities, compartments and nets in the cockpit and the rear seat area easily accommodate countless items.

For added stowage space, or when you need to carry bulky cargo, the rear seats can be split 1/3 to 2/3 or folded down entirely to provide a convenient loading area. If you also fold up the seat cushions, you can obtain a load capacity of as much as 2050 litres.

The M-Class also proves to be extremely accommodating when it comes to the loading process itself. The large wide-opening tailgate pivots upwards (power opening is available as an option)

while the low sill makes it easy to put heavy loads on board.

As an optional extra you can also equip the load compartment with the load-securing rails of the EASY-PACK load-securing kit. Load-securing rings, a telescopic bar and a belt reel can be inserted and positioned at various points in the rails.

There are six permanently fitted load-securing rings as standard which allow you to tie down luggage in the load compartment. You can also stow a part of the load in a stowage space underneath the load floor. So just about everything that has room in your life fits into the M-Class. The only thing there's no room for is compromises.

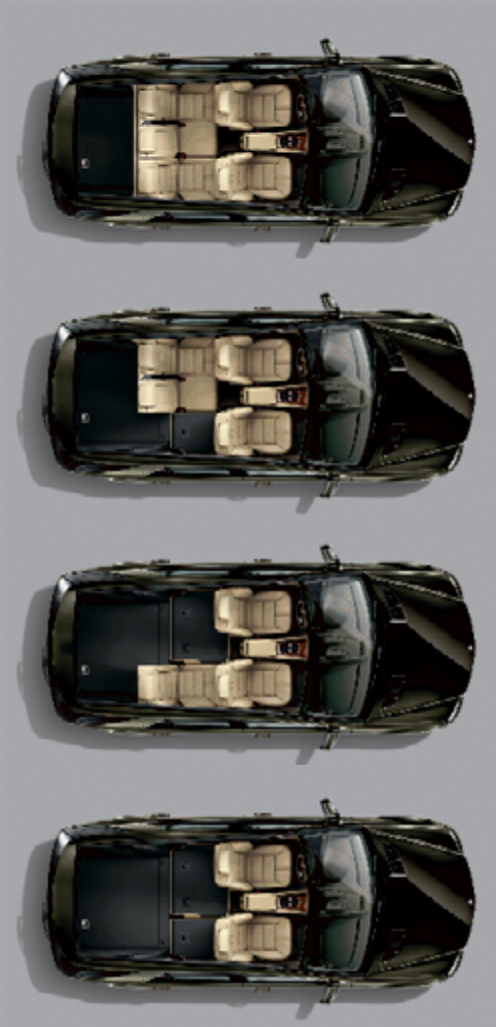



For others it's an expedition. For you it's a shortcut

Extended off-road capability thanks to the Off-Road Pro engineering package

If you have a real thirst for adventure and plan to explore extreme terrain, the optional Off-Road Pro engineering package (not available for ML 63 AMG) allows you to increase the grip and cross-country capability of the M-Class. In models equipped with the AIRMATIC electronically controlled damping system, it is possible to raise the vehicle's ride height by up to 90 millimetres and so attain a fording depth of 600 millimetres.

AIRMATIC is standard in the ML 450 CDI and ML 500 and otherwise an optional extra.

The underguard included in the package defies debris, rocky crags and deep puddles. An M-Class with this equipment has angles of approach and departure of 31° and can take a 35° cross-slope tilt angle in its stride. Even one-in-one gradients can be overcome thanks to a two-speed transfer case with a low range.

The 7G-TRONIC automatic transmission makes it possible to switch over to manual mode while on the move or standing still. Once it is in manual mode, gears are selected by means of steering wheel gearshift paddles.

All of this helps make you feel at home, no matter how far off the beaten track the Off-Road Pro engineering package takes you.

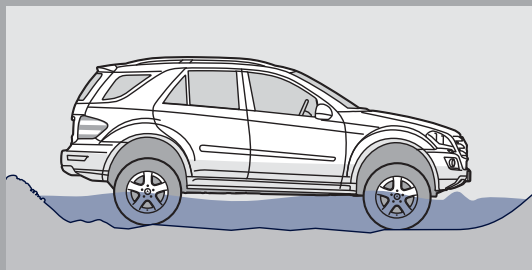

Maximum fording depth: 600 mm

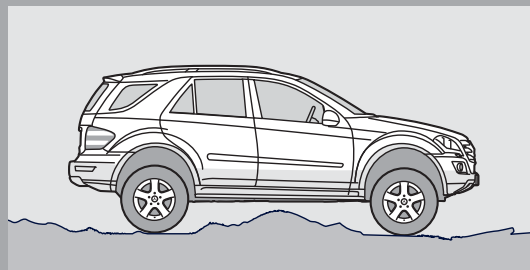

Ground clearance: up to 299 mm

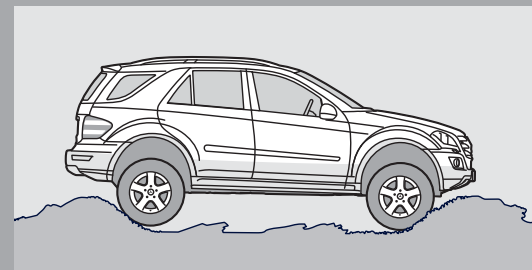

Angles of approach and departure: up to 31°





Plain sailing: 4MATIC with ESP®

All-wheel drive and trailer stabilisation – technology that pulls together

Although a stretch of sea is one of the few obstacles which the M-Class is unable to overcome, the Mercedes off-roader is the ideal way of getting to the water, especially if you have a boat in tow. For one thing, there's the new manually folding trailer coupling. And then there are all the advanced technical features: the 4ETS Electronic

Traction System and ESP® incorporate ABS, acceleration skid control and active yaw control. In combination with 4MATIC, the permanent all-wheel drive, this makes for outstanding traction on practically any surface. The optional Off-Road Pro engineering package also demonstrates outstanding qualities when towing,

particularly on slippery surfaces like wet grass and soft sand, or when starting off on hills. In critical situations, ESP® trailer stabilisation comes to your assistance. Through selective braking of individual wheels it can keep the towing vehicle and trailer on course and reduce fishtailing – even when the shipping forecast is less than encouraging.



Mercedes-Benz



4MATIC

S ON2609

Take your lead from the M-Class

Drive safe, stay safe – preventive occupant protection

Always on the look-out for any hazards which may arise, the active safety systems of the M-Class employ sensors, anticipatory technology and rapid reactions to help you avoid and overcome critical situations.

In addition to the Electronic Stability Program ESP®, the Electronic Traction System (4ETS) and 4MATIC, a large number of sensors that monitor vehicle behaviour and the driving situation watch over your safety. If they establish that there is a risk of an accident, they can close the side windows and tilting/sliding sunroof and pretension the front seat belts.

If the tyres suffer a drop in air pressure, the tyre pressure loss warning system notices the change immediately and informs you. A tyre pressure monitoring system is available as an option.

There is, however, one thing which your subconscious is able to register more effectively than any sensor: the marvellous feeling of reassurance which comes from driving one of the safest off-roaders in its class.

We've put our heads together to keep yours safe

Prepared for almost anything – passive safety features

We've built the M-Class around a rigid passenger cell to keep you as safe as possible in the event of an accident. The vehicle also has energy-absorbing crumple zones and reinforced doors. The raised floor level complements the M-Class safety concept which is designed to protect you as far as possible from severe shocks and jolts in the event of an accident. Protective features for your head and neck include adaptive airbags and NECK-PRO head restraints which automatically move towards your head to actively prevent the risk of whiplash injuries.

As an option, in combination with the Memory package, we can supply your M-Class with a crash-responsive exit aid function. Windowbags are fitted as standard for the front and rear occupants while sidebags are provided for the front-seat occupants. Crash-absorbing elements in the driver's footwell are also standard – as is our sincere hope that you never find yourself in a situation where these protective features have to be deployed.



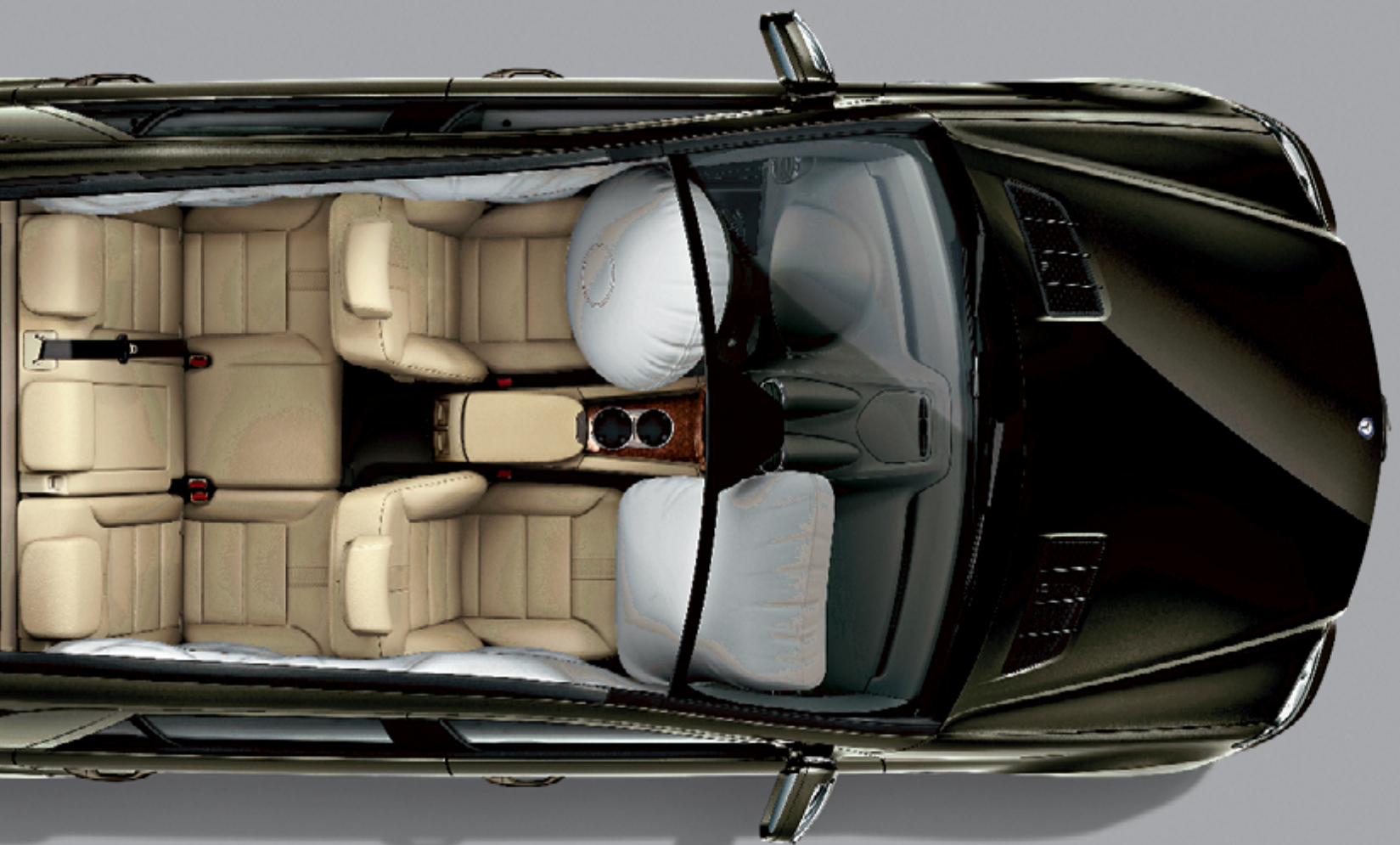

Summit of achievement

The ML 63 AMG

The ML 63 AMG doesn't just take you to exclusive places, it brings exclusivity wherever you go. One look at its dynamic AMG front apron with simulated underguard in mirror-finish chrome tells you that it is a very special vehicle. But the power and driving pleasure suggested by the appearance of the ML 63 AMG are only a foretaste of the outstanding driving experience offered by its superior technology, design and dynamism.

That experience begins in earnest with the sound of the AMG 8-cylinder engine. The promise implicit in the rich engine note is kept by the 375-kW (510-hp) output and the torque of 630 Nm at 5200 rpm. Along with the AMG sports suspension, based on the AIRMATIC package, and the AMG SPEEDSHIFT 7G-TRONIC transmission, it makes every trip an occasion, on or off the road.







Enough power to cut a dash – even in the rough

ML 63 AMG equipment details

A strong performance from start to finish – even at the rear, the ML 63 AMG loses none of its impact. Its personality is shaped by a dominant AMG rear apron and the AMG sports exhaust system with two sets of twin chrome tailpipes. High-sheen 20-inch AMG 5-spoke light-alloy wheels, painted titanium grey, with 295/40 tyres, add to the powerful impression. Optional high-sheen 21-inch AMG twin-spoke light-alloy wheels, painted titanium grey, with 295/35 tyres, are available exclusively for the ML 63 AMG.

Awaiting you inside are AMG sports seats covered with exquisite nappa leather featuring Alcantara® inserts in the shoulder area. The

AMG sports steering wheel with silver-coloured aluminium shift paddles and the AMG instrument cluster including RACETIMER evoke the world of motorsport.



Pass with distinction

The AMG bodystyling

Impressions can be heightened by the way you express yourself – with the AMG bodystyling for your M-Class, for example. The AMG front apron with simulated underguard in matt chrome adds special emphasis to the sporty side of this exceptional all-rounder.

Viewed from the front, too, the AMG bodystyling creates a strong impression with its visually large air intakes which evoke the world of motorsport.

The result is a vehicle with a presence which leaves no questions unanswered, except perhaps this one: Could anything be better looking?







ML 500



Sight of special interest

AMG bodystyling with 21-inch AMG light-alloy wheels

Noble elements play a central role in creating the unique AMG chemistry. A notable example is the powerful AMG rear apron, which, like the front one, has a matt chrome underguard. Oval, chromed tailpipes in the AMG style with AMG lettering accentuate its impressive appearance.

You'll make an even more dynamic and sporty impression with large high-sheen 21-inch AMG 5-spoke light-alloy wheels with wide 265/40 tyres.

My M-Class





Crowned in chrome

For even sharper looks: the EXTERIOR and INTERIOR Sports packages



If you want to show your passion for the sporty side of life wherever you go, we warmly recommend the EXTERIOR Sports package. It turns the M-Class into a study in dynamism. Chrome trim emphasises its exclusivity with blue-tinted glass and square chromed tailpipes striking an especially expressive note. The simulated underguard gleams in stainless steel, the roof rails have a stylish aluminium look and the sterling-silver-painted radiator grille shines with chrome highlights. Already impressive with its powerful 19-inch 5-twin-spoke light-alloy wheels, the

M-Class takes on an even more distinctive and incisive look with the optional 20-inch designer wheels or 21-inch AMG 5-spoke light-alloy wheels.

The INTERIOR Sports package ensures that the inside of the vehicle also makes a very athletic impression. Brushed stainless steel sports pedals with rubber studs complement the electrically adjustable sports seats, upholstered in a combination of Alcantara® and ARTICO man-made leather, to create an irresistibly compelling ambience.



RADIO

DISC

NAVI

TEL



SYS



ON



1

QW

2

ABC

3

DEF

4

GHI

5

JKL

6

MNO

7

PQRS

8

TUV

9

WXYZ

*

+

0

#

↑



C



OK



18

20

22

24

26

AUTO



18

20

22

24

26

22

If you want something from your M-Class, just talk to it

COMAND APS – sophisticated technology for simple operation and control

On board the M-Class, the multimedia system COMAND APS with the user-friendly NTG 2.5 telematics generation combines the entertainment and navigation functions in a central facility. Route guidance and films are displayed on the large, ergonomically positioned 6.5-inch colour display. With the optionally available TV tuner you can even watch television. You can navigate through all of Europe thanks to the integral hard

disc which includes 4 GB of memory for audio files in MP3 or WMA format.

The CD/DVD drive for audio or video is within easy reach, and the optional media interface allows you to connect COMAND APS with any USB data source – to play music from your MP3 player, for example.

If you don't want to listen to music, you can always talk to your M-Class. With LINGUATRONIC, the voice control system which is standard with COMAND APS and optional for other systems, your M-Class is always listening out for your spoken commands for functions like the radio or telephone. And the system is even able to cope with regional dialects.

Now your MP3s can ride in a Mercedes too

The M-Class audio systems

The audio systems impress with user-friendliness, high performance, and a range of functions.

A standard-fit feature is the Bluetooth® hands-free system. An Aux-in socket for mobile audio devices such as an iPod® is also integrated.

Available as an optional extra, a media interface can connect your external music memory with the audio control system of the M-Class. The music tracks can then be displayed in the instrument cluster or on the colour display of the centre console for convenient selection with the buttons of the multifunction steering wheel.

Audio 20 APS offers a CD drive as standard, Audio 50 APS a DVD drive; both feature speed-dependent volume control, colour display, double tuner for improved radio reception, and a telephone keypad.

A rich, full surround sound experience is available with the optional latest-generation Harman Kardon® Logic 7® surround sound system. With 610 watts, 12 loudspeakers and a digital signal processor (DSP) it ensures exceptionally clear and pleasurable listening.

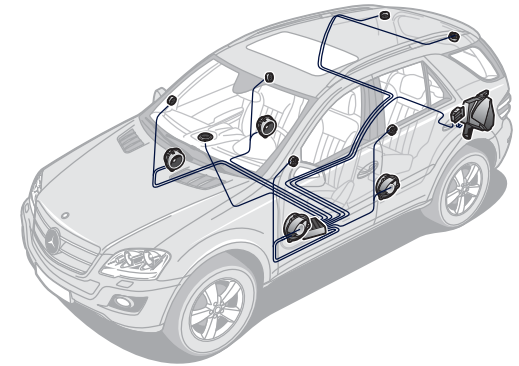

Specially positioned high-performance loudspeakers deliver incomparably rich sound



RADIO DISC

⏪ TEL

🔊 SYS

📞

⏮ ⏭

ON

TA

FM 92.2 MHz

• SWR1 Bw	2. SWR4 S
	SWR3
• SWR2 Bw	• 89.5 MHz

Radio Speicher Klang

1 QWERTZ
2 ABC
3 DEF

4 GHI
5 JKL
6 MNO

7 PQRS
8 TUV
9 WXYZ

* +
0
↕

↶ C

⬆
⬅ OK ➡
⬇

18 20 22 24 26
AUTO

🌬 MAX

🌀

🛡

22

Even “standard” means something special

Standard equipment

Like the roads and tracks it can take you along, the M-Class itself is something special. Take the standard-fit off-road switch in the centre console, for example. This feature ensures that poor roads and gravel tracks never become problematical

as it allows you to simply prime the M-Class to handle them. An agreeable temperature is ensured by the THERMATIC automatic climate control. And even changing gear becomes a pleasure rather than a chore thanks to the

DIRECT SELECT shift paddles on the steering wheel. The front seats are equipped with crash-responsive NECK-PRO head restraints for your safety while the Audio 20 audio system delivers a great listening experience.



The THERMATIC automatic climate control ensures an agreeable climate aboard



DIRECT SELECT steering-wheel shift paddles and selector lever

STANDARD EQUIPMENT (SELECTION)

 17-inch light-alloy wheels (ML 300 CDI BlueEFFICIENCY, ML 350 CDI, ML 350 BlueTEC, ML 350)

 19-inch light-alloy wheels (ML 450 CDI, ML 500)

 20-inch AMG light-alloy wheels (ML 63 AMG)

 7G-TRONIC automatic transmission

 Adaptive brake lights

 Airbags for driver and front passenger, with two-stage deployment

 Anti-lock braking system ABS

 Armrest in front, with compartment

 Audio 20 CD (with colour display, MP3 capability and Bluetooth® hands-free system)

 Aux-in socket in the glove compartment, for external audio devices

 Brake Assist (BAS)

 Dark-tinted tail lights

 DIRECT SELECT gearshift with steering-wheel gearshift paddles

 Direct-Steer system (speed-sensitive power steering)

 Door centre panel in ARTICO man-made leather

 Downhill Speed Regulation (DSR)

 Electronic Stability Program ESP®

 Electronic Traction System 4ETS for all-wheel drive

 Exhaust system, twin-pipe, with exposed tailpipes

 Exit lights (4) in front and rear doors

 'Fasten seat belt' warning for front seats

 Front fog lamps

 Headlamp Assist

 Heated exterior mirrors, electrically adjustable

 Load compartment cover

 Nappa leather multifunction steering wheel

 NECK-PRO head restraints for front seats

 Outside temperature display

 Permanent all-wheel drive

 Power windows (4) with one-touch control

 PRE-SAFE® system

 Rear bench seat, split-folding (1/3 : 2/3)

 Roll-over sensor

 Roof rails/pre-installation for roof-mounted carriers

 Sidebags for driver and front passenger

 Simulated front underguard, silver-coloured

 THERMATIC automatic climate control

 Third brake light featuring LED technology

 Tyre pressure loss warning system

 Windowbags for driver, front passenger and rear passengers

If you want it, we've probably already thought of it

Optional extras

OPTIONAL EXTRAS (SELECTION)

SAFETY

Anti-theft alarm system with tow-away protection

Bi-xenon headlamps with active light function, headlamp cleaning system, dynamic headlamp range adjustment, cornering light function in bumper and LED tail lights in clear-lens look

Crash-responsive exit aid (in combination with Memory package)

Headlamp cleaning system

Sidebags in rear

COMFORT

Auxiliary heater

EASY-PACK load-securing kit with load-securing rails and removable rear seat cushions

EASY-PACK tailgate, hydraulically operated (can also be closed by pressing button on vehicle key)

Electrically adjustable front seats, with Memory package (driver's seat, steering column and exterior mirrors electrically adjustable, with Memory function)

Heated seats for driver and front passenger (standard for ML 63 AMG)

Heated windscreen washer system including heated washer nozzles

Lumbar support with 4-way electric adjustment

Multicontour seats for driver and front passenger (standard for ML 63 AMG)

PARKTRONIC

THERMOTRONIC luxury automatic climate control

Tilting/sliding glass sunroof, electric

Trailer coupling, folding

Windscreen wipers with rain sensor (standard for ML 450 CDI, ML 500, ML 63 AMG)

RADIO/COMMUNICATION

Audio 50 APS (plus DVD arrow-based navigation and junction-zoom function)

CD changer for 6 CDs, MP3-compatible

COMAND APS, control and display system for audio, navigation and telephone, incl. high-resolution 6.5-inch display, hard-drive navigation, MUSIC REGISTER and LINGUATRONIC voice control system

DVD changer (for 6 DVDs)

Harman Kardon® Logic 7® surround sound system with 12 loudspeakers

Rear Seat Entertainment System

DESIGN

21-inch AMG 5-spoke light-alloy wheels, high-sheen finish

Aluminium-look running boards (standard for ML 63 AMG)

AMG bodystyling (standard for ML 63 AMG)

Dark-tinted glass for rear side windows and rear window

Dashboard in ARTICO man-made leather

Tyre pressure monitoring system

Wood/nappa leather multifunction steering wheel

Your wish is our command: equip your M-Class with even more exclusive appointments; such as the Rear Seat Entertainment System with

8-inch screens, wireless headphones and remote control. Or with a two-tone leather interior complete with black roof lining. The driver will

also appreciate the DISTRONIC automatic proximity control – and the parking comfort afforded by the PARKTRONIC parking aid.



The Rear Seat Entertainment System with two screens in the front head restraints



Tilting/sliding glass sunroof, electric

If you like the idea of driving a highly exclusive Mercedes, but don't have the time to ponder over every detail of its equipment, the M-Class has the answer.

Assembled to meet the most sophisticated requirements, the appointments and Sports packages are always a good choice. The only thing you have to decide now is which of the packages suits you best.



Leather-covered dashboard



Wood/nappa leather multifunction steering wheel



Tail light in clear-lens look, with LED technology



Aluminium-look running boards

EXTERIOR

AIRMATIC package (standard for ML 450 CDI, ML 500 und ML 63 AMG):
air suspension, front/rear, with level control, Adaptive Damping System (ADS)

AMG bodystyling¹

Front and rear apron with underguard in matt chrome, AMG oval tailpipes (chromed).
See pages 46 to 49

EXTERIOR Sports package²

Chromed square tailpipes, roof rails in aluminium look, chrome trim (rub strip, shoulder line trim strip), chromed load sill guard on rear bumper, "sterling silver" radiator grille with chrome, 5-twin-spoke light-alloy wheels (4), 8 J x 19 ET 60, tyre size 255/50 R 19, simulated underguard front and rear (stainless steel), blue-tinted windows all round

Off-Road Pro engineering package²

Two-speed transfer case with additional low-range reduction gearing, automatic or manually selectable multiple-disc limited-slip centre differential with up to 100 % lock, manually selectable multiple-disc limited-slip rear-axle differential with 100 % lock, front-axle locking as required with 4ETS brake intervention, extended adjustment range for air suspension system (30 mm increase in ground clearance versus AIRMATIC package), selectable transmission control mode (Standard (S) or Manual (M)), compass, underguard

INTERIOR

INTERIOR Sports package²

Front sports seats, electrically adjustable, with 4-way lumbar support on driver's side; sports instrument cluster, Interior Light package (illuminated door handle recesses front and rear, illuminated stowage compartment and illuminated cup holder in front centre console, footwell lighting in rear); Alcantara®/ARTICO man-made leather upholstery combination with contrasting stitching and five-section cross-fluting; brushed stainless steel sports pedals with rubber studs (incl. foot-operated parking brake)

designo

see pages 68 to 71

¹ Standard for ML 63 AMG with specific front and rear apron

² Not available for ML 63 AMG

Perfect right down to the ground

Numerous wheel designs are available for the M-Class, depending on the engine size. A 17-inch and an 18-inch wheel, two 20-inch and two 21-inch wheels, and three 19-inch wheels accentuate the off-roader's expressive appeal.



High-shine 21-inch AMG twin-spoke light-alloy wheel, painted in titanium grey (optional for ML 63 AMG)



17-inch 7-spoke light-alloy wheel
(standard on V6 models)



19-inch 5-twin-spoke light-alloy wheel
(included in Sports package)



19-inch 5-spoke light-alloy wheel
(standard for V8 models, optional for V6 models)



20-inch AMG 5-spoke light-alloy wheel
(standard on ML 63 AMG)



18-inch 5-spoke light-alloy wheel
(at no extra charge, optional for V6 models)



19-inch 5-spoke light-alloy wheel with
mixed-size tyres (optional)



20-inch 5-twin-spoke light-alloy wheel
(optional)



21-inch AMG 5-spoke light-alloy wheel
(optional extra, not for ML 63 AMG)



Make more of your M-Class

Driving a Mercedes-Benz is more than just an enjoyable experience. It can also have a highly practical side thanks to useful accessories such as the aerodynamic roof box or the ski and snowboard rack. Of course, you can always add more visual highlights, too: incenio designer wheels, for example. These accessories, and the many others which are available, reflect a varied range of interests while also demonstrating that only Mercedes-Benz genuine accessories are a perfect fit for a Mercedes-Benz.

To find out more, please see our Accessories brochure or consult your Mercedes-Benz dealer who will be pleased to advise you.

More scope for personal wishes: incenio designer wheels, side protection bars with steps, basic carrier bars and ski and snowboard rack



The practical roof box in three sizes, fitted to the basic carrier bars



The boot tub (deep) helps to keep the load compartment clean. Made from food safe material

Every stitch a masterpiece

The designo range

The uniqueness of the designo range reflects the unique quality of the resources used to create it. The finest materials are selected with great care and hand-crafted to form exclusive wood trim elements and sumptuous upholstery. You feel designo every time you touch a seam, you recognise it when you see the perfectly finished surfaces and you smell it in the rich aroma of the fine leather.







Personal best

The designo details

designo appointments allow you to give the interior of your vehicle a look and feel which reflect your individual style. The starting point for this is the extended range of colours available with designo. Each of the four leather colours lends the interior its own special character. The sports seats in high-grade designo leather are available in the colours designo black, designo cashmere

beige, designo porcelain and designo light brown. The comfortable seats have an attractive, sporty design with seven-section longitudinal fluting and a matt chromed designo badge. In addition, the lid of the armrest between the front seats is in the chosen designo leather colour, as are the door centre panels.

The trim elements that go with the designo appointments are available in designo brown popular or designo umber maple grain. High-quality designo velour floor mats with black designo leather edging and a metal designo badge round off the designo appointments.



The exclusive leather instrument cluster



designo stands for carefully chosen materials

The paintwork of the M-Class puts the finishing touch to the carefully crafted Mercedes-Benz corrosion protection system, which includes zinc phosphating and electrophoretic dip priming stages for long-lasting protection. Furthermore, Mercedes-Benz makes extensive use of eco-friendly water-based paints.

NON-METALLIC PAINT



040 black



650 calcite white

METALLIC PAINT



197 obsidian black



359 tanzanite blue



544 carneol red

SPECIAL METALLIC PAINTS



755 tenorite grey



798 sanidine beige



349 lazurite blue



775 iridium silver



474 peridot brown



792 palladium silver

ARTICO MAN-MADE LEATHER/
ASPEN FABRIC¹



001 black

ARTICO MAN-MADE LEATHER/
ALCANTARA® FABRIC²

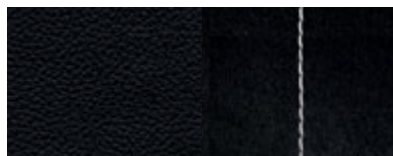

911 black

ARTICO MAN-MADE LEATHER³

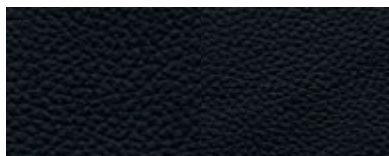

151 black

LEATHER⁴

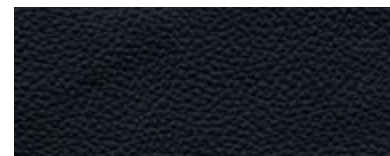

221 black⁵



918 alpaca grey

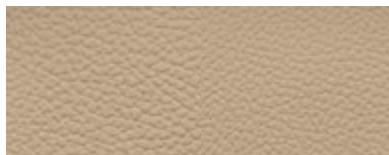

154 cashmere beige

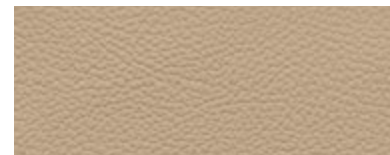

224 cashmere beige⁵



158 alpaca grey

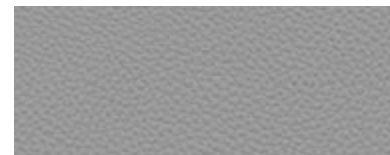

228 alpaca grey⁵

¹ Standard for ML 300 CDI BlueEFFICIENCY, ML 350 CDI, ML 350 BlueTEC and ML 350

² Optional extra, only in conjunction with INTERIOR Sports package

³ Optional extra, standard for ML 450 CDI and ML 500

⁴ Optional extra

⁵ ML 63 AMG, nappa leather trim as standard (available in black, cashmere beige and alpaca grey)

⁶ Not available for the ML 63 AMG

designo NAPPA LEATHER⁶



264 cashmere beige/black



X11 black

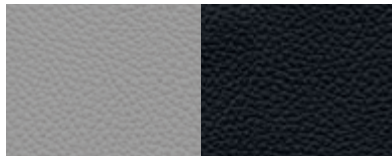

268 alpaca grey/black



X25 cashmere beige

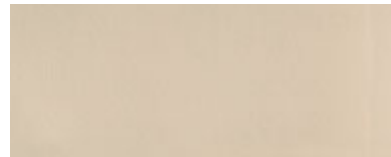

X27 porcelain



X35 light brown

TRIM ELEMENTS

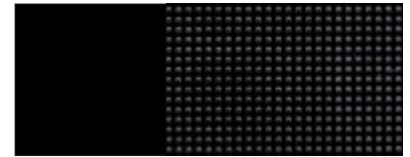

739 aluminium silver/black

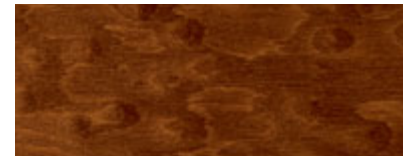

H04 bird's-eye poplar



729 anthracite poplar with chrome highlights



731 burr walnut with chrome highlights



Paintwork and upholstery – the combination options

	ARTICO MAN-MADE LEATHER/ASPEN FABRIC ¹	black	ARTICO MAN-MADE LEATHER/ALCANTARA ²	black	alpaca grey	ARTICO MAN-MADE LEATHER ³	black	cashmere beige	alpaca grey	LEATHER ^{4,5}	black	cashmere beige	alpaca grey	cashmere beige/black	alpaca grey/black
NON-METALLIC PAINTS															
black	●		●	●		●	●	●			●	●	●	●	●
calcite white	●		●	●		●	○	●			●	○	●	○	●
METALLIC PAINTS															
obsidian black	●		●	●		●	●	●			●	●	●	●	●
tanzanite blue	●		●	●		●	○	●			●	○	●	○	●
carneol red	●		●	●		●	●	●			●	●	●	●	●
tenorite grey	●		●	●		●	●	●			●	●	●	●	●
iridium silver	●		●	●		●	○	●			●	○	●	○	●
palladium silver	●		●	●		●	△	●			●	△	●	△	●
sanidine beige	●		●	△		●	●	△			●	●	△	●	△
SPECIAL METALLIC PAINTS															
lazurite blue	●		●	●		●	△	●			●	△	●	△	●
peridot brown	●		●	○		●	●	○			●	●	○	●	○

● Recommended

○ Possible

△ Not recommended

¹ Standard for ML 300 CDI BlueEFFICIENCY, ML 350 CDI, ML 350 BlueTEC and ML 350² Optional extra, only in conjunction with INTERIOR Sports package³ Optional extra, standard for ML 450 CDI and ML 500⁴ Optional extra⁵ ML 63 AMG, nappa leather trim as standard (available in black, cashmere beige and alpaca grey)

Technical data

	ML 300 CDI 4MATIC BlueEFFICIENCY	ML 350 CDI 4MATIC	ML 350 BlueTEC 4MATIC	ML 450 CDI 4MATIC	ML 350 4MATIC	ML 500 4MATIC	ML 63 AMG 4MATIC
No. of cylinders/arrangement	6/V	6/V	6/V	8/V	6/V	8/V	8/V
Total displacement (cc)	2987	2987	2987	3996	3498	5461	6208
Rated output ¹ (kW at rpm)	140/4000	165/3800	155/3400	225/3600	200/6000	285/6000	375/6800
Rated torque ¹ (Nm at rpm)	440/1400–2800	510/1600–2800	540/1600–2400	700/2000–2600	350/2400–5000	530/2800–4800	630/5200
Top speed, approx. (km/h)	205	215	210	235	225	250 ²	250 ²
Acceleration 0–100 km/h (s)	9.8	8.6	8.7	6.5	8.4	5.8	5.0
Tyre size	235/65 R 17	235/65 R 17	235/65 R 17	255/50 R 19	235/65 R 17	255/50 R 19	295/40 R 20
Fuel	Diesel	Diesel	Diesel	Diesel	Premium unleaded	Premium unleaded	Super Plus
Fuel consumption ³ (l/100 km)							
urban	10.8–11.8	10.8–12.0	11.9–12.2	14.2–14.6	15.2–15.7	18.0	24.1
extra-urban	6.9–7.9	7.4–8.0	6.7–7.2	8.5–9.1	9.2–9.9	10.2	12.2
combined	8.4–9.3	8.9–9.5	8.7–9.1	10.6–11.0	11.4–12.0	13.1	16.5
CO ₂ emissions ³ (g/km)	222–246	235–250	231–239	279–292	266–281	304	392
Tank capacity (l)/incl. approx. reserve	95/13	95/13	95/13	95/13	95/13	95/13	95/15
Turning circle diameter (m)	11.6	11.6	11.6	11.6	11.6	11.6	11.6
Kerb weight ⁴ (kg)	2185	2185	2185	2315	2135	2185	2310
Perm. GVW (kg)	2830	2830	2910	2950	2830	2830	2880

¹ Figures in accordance with Directive 80/1269/EEC in the currently applicable version ² Electronically governed ³ The figures shown were obtained in accordance with the prescribed measuring process (Directive 80/1268/EEC in the currently applicable version). The figures are not based on an individual vehicle and do not constitute part of the product offer; they are provided solely for purposes of comparison between different vehicle models. ⁴ Figures according to Directive 92/21/EC, version 95/48/EC (kerb weight with fuel tank 90% full, driver, 68 kg, and luggage, 7 kg) for standard-specification vehicles. Optional extras and accessories will generally increase this figure and reduce the payload capacity accordingly

	ML 300 CDI 4MATIC BlueEFFICIENCY	ML 350 CDI 4MATIC	ML 350 BlueTEC 4MATIC	ML 450 CDI 4MATIC	ML 350 4MATIC	ML 500 4MATIC	ML 63 AMG 4MATIC
Perm. towing capacity¹ (kg) braked/unbraked	3500/750	3500/750	3500/750	3500/750	3500/750	3500/750	3500/750
Load capacity (l) max. behind 2 nd row of seats max. behind 1 st row of seats	833 2050	833 2050	833 2050	833 2050	833 2050	833 2050	833 2050
OFF-ROAD PERFORMANCE							
Fording depth, standard susp./ Off-Road Pro eng. package (mm)	500/600	500/600	500/600	500/600	500/600	500/600	500/-
Angle of approach/departure² (degrees)	26°/26°	27°/26°	27°/26°	25°-31°/24°-29°	27°/26°	25°-31°/24°-29°	19°-24°/21°-26°
Minimum ground clearance, front/rear² (mm) standard suspension with Off-Road Pro engineering package ³	201/214 186-291/194-299	210/223 186-291/194-299	210/223 186-291/194-299	186-261/194-269 186-291/194-299	210/223 186-291/194-299	186-261/194-269 186-291/194-299	153-234/162-242 -
Gradient climbing ability^{2,4} (%)	100	100	100	100	100	100	100
Maximum breakover angle (degrees) standard suspension with Off-Road Pro engineering package ³	16° 14°-23°	17° 14°-23°	17° 14°-23°	14°-21° 14°-23°	17° 14°-23°	14°-21° 14°-23°	14°-21° -
Low-range ratio⁵	2.93 : 1	2.93 : 1	2.93 : 1	2.93 : 1	2.93 : 1	2.93 : 1	-
Power distribution of permanent all-wheel drive	50 : 50	50 : 50	50 : 50	50 : 50	50 : 50	50 : 50	40 : 60

¹ Including drawbar load of 140 kg

² Figures according to Directive 70/156/EEC, version 2000/40/EC

³ Basic setting front/rear (mm): 201/209

⁴ Minimum 60% (= 31°), depending on surface and traction levels

⁵ Only with Off-Road Pro engineering package

The dimensions of the M-Class

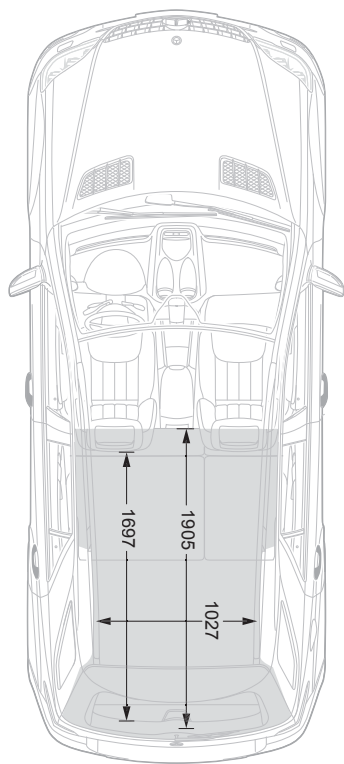

2 seats

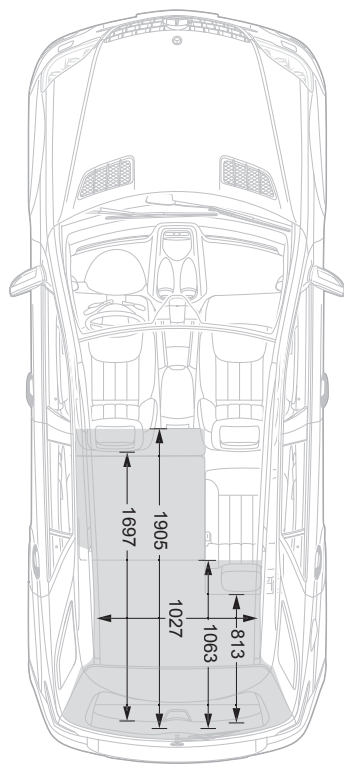

3 seats

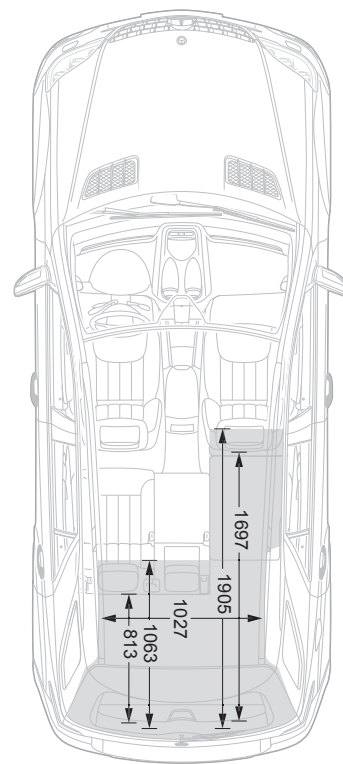

4 seats

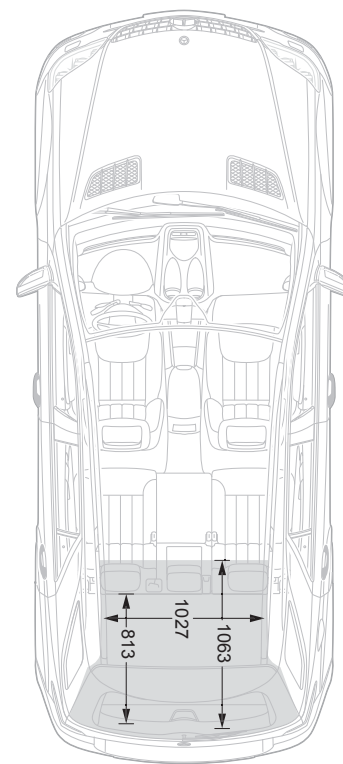

5 seats

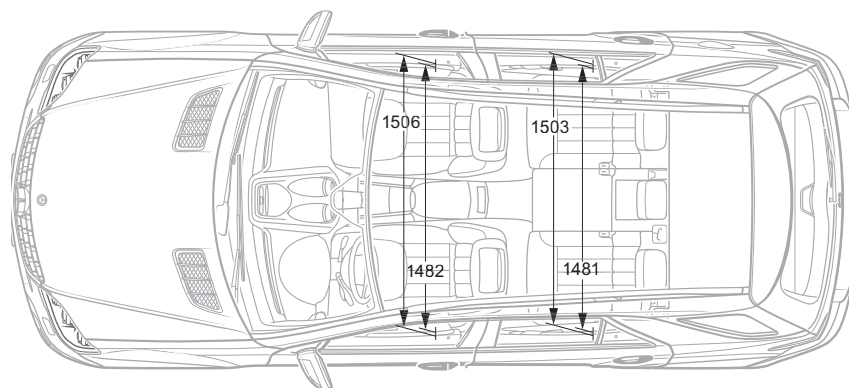
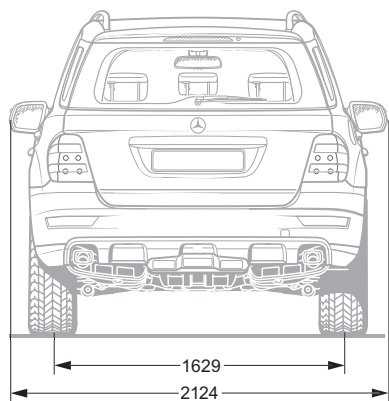
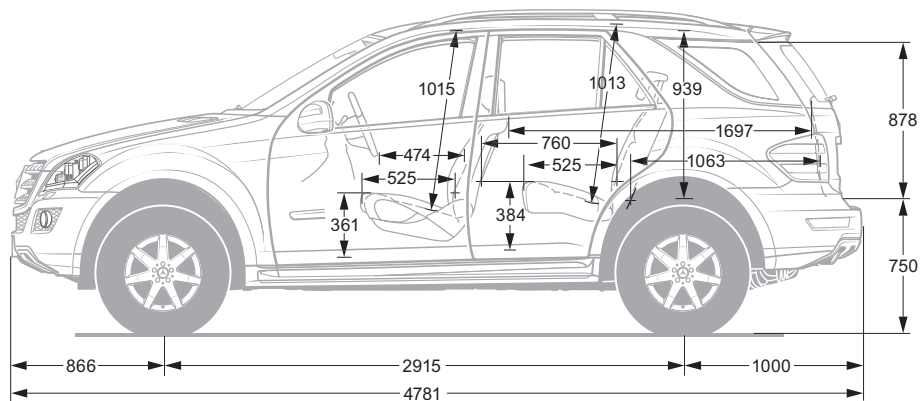
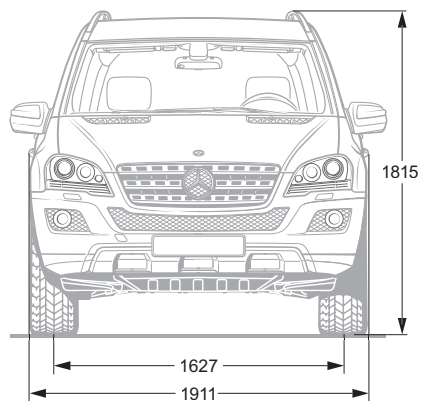

All figures in mm. The dimensions shown are mean values and apply to unladen vehicles featuring the optional extra off-road styling package



Mercedes-Benz mobility. Your new car comes with the assurance of carefree driving, but if you should ever need assistance Mercedes-Benz Service24h is there for you. Just call the freephone service hotline on 00800 1 777 7777¹. The newly integrated telematics service Mercedes-Benz Contact² is even more customer-friendly: a touch of a button is all it takes to contact the Mercedes-Benz customer centre by telephone. And if you wish, all the relevant vehicle and position data can be transmitted at the same time, thus ensuring the shortest possible reaction time and rapid on-the-spot help. Another benefit which comes as standard with your new car at no extra charge is the Mercedes-Benz Mobilo³ mobility package. Whether you have lost your key, have had a breakdown which cannot be repaired immediately or if the vehicle is damaged as a result of an accident or vandalism, Mobilo ensures that you still reach your destination – anywhere in Europe. Whatever the problem, one thing is certain: you will soon be able to resume your journey.

¹ Charges for calls made from mobile phones may vary, depending on service provider

MercedesCard. Your ticket to the Mercedes-Benz experience: the quarterly MercedesCard ARGENTUM journal offers you an exclusive selection of exciting events starring the Mercedes-Benz brand. In addition to this, the Mercedes Magazine is packed with interesting and inspiring articles and reports. The MercedesCard has many other functions: as a VISA credit card, it is an accepted form of payment worldwide – with no annual fee if you complete a questionnaire every year. In addition, it offers further benefits to put your mind at ease, such as the Mercedes-Benz insurance package, at no extra charge, and the specially designed MercedesCard insurance package at a preferential rate. For further information about this offer, available exclusively to Mercedes-Benz drivers, visit www.mercedes-benz.de/mercedescard⁴

² Prerequisite: ex factory radio linked to a mobile phone which is operating. The only charge incurred is the cost of the mobile phone call to a landline

³ When the warranty has expired Mobilo can be extended by another year for a maximum of 30 years, provided that regular maintenance is carried out by your Mercedes-Benz service partner

⁴ Information about the MercedesCard in Austria and Switzerland can be found on the Mercedes-Benz websites for these countries

Mercedes-Benz Bank. If you have already chosen your dream car and want to remain financially flexible, the Mercedes-Benz Bank should be your next port of call. It is your one-stop shop for leasing, financing, insurance and service packages. By way of example, our “Private Leasing Plus” scheme is a complete package comprising leasing, third-party insurance and fully-comprehensive insurance as well as a purchase option. Meanwhile, our “Plus3” financing combines the low repayment rates of a financing scheme with the flexibility of leasing. You then have three options at the end of the contract: you can keep the car, sell it, or return it to us for a guaranteed price and switch to a new model. In addition to this, we can offer you a range of investment products such as instant-access savings accounts, fixed-interest products and investment funds. For further information, please call us on 01803/32 22 65⁵ or visit us at www.mercedes-benz-bank.de

⁵ 9 ct./min from Deutsche Telekom landlines, mobile-phone rates may vary



Time for another enriching experience

Test drive the vehicle of your dreams

A Mercedes-Benz is most at home on the road. This is the only way to experience the effortlessly superior driving feel that lends every model its inimitable class. Feel the power of the engine as it propels the car forwards. Marvel at the precise steering, designed to really put you in the mood for driving. And experience what true comfort really feels like. The unique feeling of driving a Mercedes cannot be put into words, however. Which is why we'd like to invite you to take a test drive. Your Mercedes-Benz dealer will be happy to make all the necessary arrangements for you. Simply visit www.mercedes-benz.com to locate the nearest Mercedes-Benz dealer in your country or region. We look forward to seeing you.

The website also offers an interactive tour, enabling you to take a closer look at your desired model. This simulation is the ideal way to acquaint yourself with your dream car. You can view key functions in detail, gain an insight into the car's inner workings or look at the benefits of each model. For further details, visit www.mercedes-benz.de/owners-manual

Take-back of end-of-life vehicles. At the end of its long life, you can return your M-Class to us for environment-friendly disposal in accordance with the EC End-Of-Life Vehicle Directive¹. But that day lies a long way off.

¹Applies in accordance with national regulations to vehicles up to 3.5 tonnes gross weight. Mercedes-Benz passenger cars have met the statutory regulations governing the suitability of their design for reuse and recycling for a number of years now. A network of vehicle take-back depots and dismantlers has been established which will process your vehicle in an environment-friendly manner. The ways in which both vehicles and parts can be recovered are subject to ongoing development and improvement. Consequently, the M-Class will be able to comply with any future increases in the recycling quota within the stipulated time limits. For further information, please call 00800 1 777 7777

Please note: changes may have been made to the product since this brochure went to press (09.02.2009). The manufacturer reserves the right to make changes to the design, form, colour and specification during the delivery period, provided these changes, while taking into account the interests of the vendor, can be deemed reasonable with respect to the purchaser. Where the vendor or the manufacturer uses symbols or numbers to describe an order or the subject of an order, no rights may be derived solely from these. The illustrations may show accessories and items of optional equipment which are not part of standard specification. Colours may differ slightly from those shown, owing to the limitations of the printing process. This brochure has been compiled by Daimler AG of Germany and is distributed internationally. It provides a general indication of the range of models, features, optional extras, colours and/or services available in various countries. Some of the models, features, optional extras, colours and/or services may not be available in your country, or may only be available in a different specification. Additionally some models, features, optional extras, colours and/or services may only be available in combination with others. For current and more specific information in relation to the range of models, features, optional extras, colours and/or services available in your country, and their pricing, you should contact your nearest authorised Mercedes-Benz Passenger Car Dealer. www.mercedes-benz.com