

This Brochure is prepared by Daimler AG and it predominantly reflects the capabilities and performance of vehicles sold in Europe. Some characteristics, capabilities, performance features and optional extras (e.g. towing systems) may not be available or may not apply in Australia or under Australian conditions. The information in this Brochure is therefore indicative, illustrative and provided only for guidance and should not be relied on. To obtain current and accurate information on a vehicle and any options applicable to Australia, contact your local authorised Mercedes-Benz dealer.



Mercedes-Benz

# The B-Class



Mercedes-Benz





pared for virtually everything right from the start: the B-Class has a particularly safety interior with high-quality materials has the capacity to make life easier, while the exterior, the struggle for control of the rear seat. When one pair of eyes is not enough, the B-Class at an early stage if you happen to glance behind you for an instant. Up to ten more assist your head? Its compact exterior fits into just about any parking space, its interior is and can even be increased with the optional EASY-VARIO-PLUS system. Well thought-out of short legs in its stride, will still be in great shape by the time their owners are teenagers can be used again and protect resources. And in case you don't think that the standard-spaces that bit greener - irrespective of the paint colour you've chosen. Wherever you go in a distinctive character. Metallic surfaces in fine silver chrome reflect self-assurance, painstaking cold shoulder. **For what's coming up.** for the rear windows is a cool way of giving privacy. When a couple gets a couple of new additions, it's good to be able to count on another





Families might not be able to plan everything, but they can count on anything happening. The B-Class meets the demands that daily life has in store for you. Generous amounts of space demonstrate a great sense of order. The confident, sporty exterior and high-quality interior are stylish companions on every journey. Numerous assistance systems pamper you and ease the burden on you or help ensure safety, the standard-specification COLLISION

PREVENTION ASSIST being a case in point. And efficient engines, combined with clever BlueEFFICIENCY measures, make being out on the road as harmless to the environment as possible. Because there's no finer thing than a future. Because you are already thinking of tomorrow today. And because the next generation always has priority. The B-Class. For what's coming up.

At a glance | from page 4    Insight | from page 20

<b>Featured models:</b>
<b>B 200 CDI BlueEFFICIENCY   polar silver  </b> cover and from page 2 Night package, Sports package, Exclusive package, light-alloy wheels painted black, hazelnut brown leather, high-gloss black ash wood
<b>B 180 BlueEFFICIENCY   jupiter red  </b> from page 12 Chrome package, AMG 5-twin-spoke light-alloy wheels, crystal grey Domburg fabric, matrix-look trim

The illustrations may show accessories and items of optional equipment which are not part of standard specification

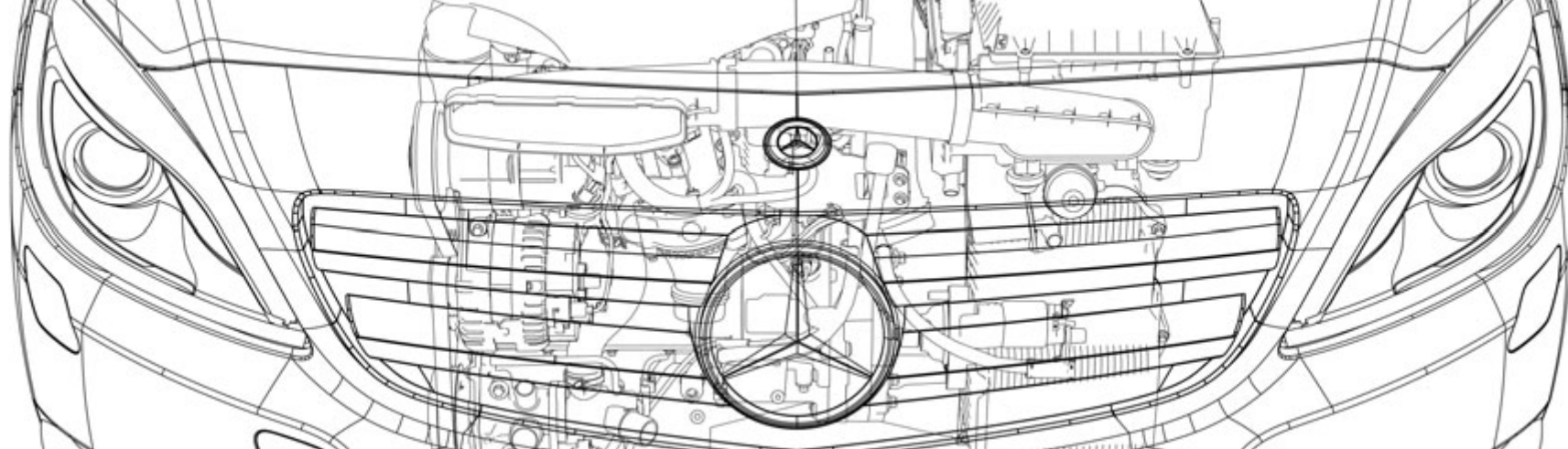

**For driving enjoyment on every road:** BlueEFFICIENCY, diesel and petrol engines, Natural Gas Drive, Direct-Steer system and sports suspension.

Drive system & chassis | from page 28

**For a safe journey:** the latest technologies in the integral safety concept for the “Safe driving”, “In the event of danger”, “In an accident” and “After an accident” phases.

Safety | from page 36

**For luxury in everyday life:** standard-specification and optional comfort, such as multimedia and assistance systems, Becker® MAP PILOT, intelligent variability, the Memory package and Light and Sight package.

Comfort | from page 40

**For always having the choice:** generous standard equipment, Chrome, Sports, Night and Exclusive packages to meet individual requirements, wheels and genuine accessories.

Equipment & appointments | from page 48

**For the best service:** MercedesCard, Mercedes-Benz Financial Services, Mercedes-Benz mobility, Mercedes-Benz Museum, test drive, Interactive Owner’s Manual and Mercedes-Benz Guides, mobile internet, service packages, accident repairs.

Services | from page 72

**For all the details:** technical data, dimensions and paintwork.

Facts & colours | from page 74





## Who says responsibility can't be fun?

When a couple gets a couple of new additions, it's good to be able to count on another member of the family who is prepared for everything right from the start: the B-Class has a particularly safety-conscious character because it can identify what the road ahead has in store for you at a distance of several metres. Its spacious interior with high-quality materials has the capacity to make life easier while the exterior impresses with a self-assured face, high-tech headlamps and dynamically sculpted sides.







Five seats.  
And space for a whole family











In front of you, the traffic; behind you, the struggle for control of the rear seat. When one pair of eyes is not enough, the B-Class has another set on hand: the standard-fit COLLISION PREVENTION ASSIST system keeps “looking” ahead resolutely to spot hazards at an early stage if you happen to glance behind you for an instant. Up to ten more assistance systems ensure that the B-Class is a decidedly safe haven for your family. Who says you can’t have eyes in the back of your head? → Page 36, 37, 42, 43

I may be looking to the right,  
but I’m looking straight ahead, too



Its compact exterior fits into just about any parking space, its interior is your second home: the B-Class has a boot whose 488-litre capacity allows it to swallow everything from a pushchair to the weekly shop – and can even be increased with the optional EASY-VARIO-PLUS system. Well thought-out stowage facilities provide accommodation for every last item. And the back seat, which is able to take sustained punishment from up to three pairs of short legs in its stride, will still be in great shape by the time their owners are teenagers. → Page 44, 45













## Green now comes in jupiter red too

With the B-Class you're already well placed to meet the demands of the future with regard to saving fuel, reducing emissions, recycling materials and conserving resources. And in case you're thinking that the standard-specification BlueEFFICIENCY measures – such as the ECO start/stop function – don't go far enough, it's good to know that one of the best  $c_d$  values in its class makes your B-Class that bit greener – irrespective of the paint colour you've chosen.

→ Page 28, 29







What tomorrow will bring? I'd rather know  
what's round the next bend









A long-exposure photograph of a city street at night, showing significant motion blur. The scene is dominated by horizontal streaks of light and color, primarily in shades of blue, purple, and white. On the right side, there are bright, vertical streaks of red and white light, likely from traffic lights or streetlights. The background shows the silhouettes of buildings and trees, all rendered as soft, out-of-focus shapes. The overall effect is one of rapid movement and vibrant, artificial light.

Of course I can also do the ten kilometres on the treadmill.  
It's just that the B-Class makes me look so much better







Wherever you go in the B-Class, you go in style. Four fine equipment packages and additional optional extras offer you unrivalled scope for expressing your own distinctive character. Metallic surfaces in fine silver chrome reflect self-assurance, painstaking attention to detail creates an ambience of wellbeing, dark-tinted heat-insulating glass for the rear windows is a cool way of giving prying eyes the cold shoulder. With all these possibilities, the B-Class demonstrates to perfection that good taste has at least as many dimensions as you do. → Page 48-67



We invest over 700 crashes per annum  
in the safety of our vehicles







In the crash-test hall at Mercedes-Benz, every model is tested to assess its performance in minor and severe collisions as well as in impact situations from the front, from behind, from the side and from above. On the basis of the results we develop the best possible impact protection for our vehicles. Around 700 cars a year “go to the wall” in our schedule of precise testing.

But crash tests are only the most spectacular part of the Daimler safety philosophy. Our integral safety concept blends numerous active and passive safety systems, to enable you to benefit from even higher standards of safety and an even more assured driving experience when out on the road. Above all, it is designed to enable a potential accident to be detected in advance and to reduce the severity of the accident if the worst should come to the worst.

This is why the B-Class’s standard-specification COLLISION PREVENTION ASSIST monitors the area in front of the vehicle at speeds from 30 to 250 km/h. If it recognises a hazard, it can alert the driver and thus help prevent rear-end collisions.

As of now, this happens in the best of families







Be honest: do your little passengers in the rear sometimes forget that they aren't all alone in the world? Are they sometimes to be seen preparing for their glittering singing career while you're waiting at the lights? Have they been known to empty a packet of biscuits all over the rear seat in the supermarket car park? Is the temptation to make funny faces at the people in the next lane of traffic too great for them to resist? Do they, in fact, have a distinct tendency to simply be children?

The B-Class makes it easy to be yourself without getting any strange looks: as soon as you get in and close the door, you'll find that the painstakingly designed interior becomes a home from home for you and your family. And because feeling at home is also about feeling secure from prying eyes, a dark-tinted rear window and rear side windows are available as an option. With this much privacy there is only one thing left for the world to see: a model family.





EFFICIENCY. Assistance systems. Upholstery and trim. In an accident. Metallic paints. Sound speed. Chassis & suspension. Optional extra. Fuel consumption. Interior. In the event of a crash. Climate control. Seats. ESP<sup>®</sup>. Dimensions. Standard equipment. Light. Multimedia system. Light-alloy wheels. Memory package. Transmission. Surround sound system. Wheels. Interior. Services. Upholstery and trim. Assistance systems. BlueEFFICIENCY. In an accident. Light-alloy wheels. Top speed. Chassis & suspension. Optional extra. Fuel consumption. Displacement. Facts and colours. Climate control. Seats. ESP<sup>®</sup>. Dimensions. Standard equipment & appointments. CO<sub>2</sub> emissions. Memory package. Transmission. Surround sound system. Cylinders. Technical data. Interior. Services. Safety. Assistance systems. Upholstery and trim. In the event of a crash. Safe driving. Light-alloy wheels. Top speed. Optional extra. Chassis & suspension. Engines. **The facts.** Paintwork. Total displacement. Climate control. Seats. Dimensions. Standard equipment & appointments. Light-alloy wheels. Memory package. Transmission. Surround



28 **BlueEFFICIENCY**29 **B-Class BlueEFFICIENCY**30 **Diesel engines**

4-cylinder

31 **Petrol engines**

4-cylinder

32 **Natural Gas Drive**

B 200 Natural Gas Drive

34 **Transmissions**

6-speed manual transmission

7-speed 7G-DCT dual clutch transmission

35 **Chassis and suspension**

Chassis and steering

Sports suspension

Direct-Steer system

36 **Integral safety concept**

ATTENTION ASSIST

ADAPTIVE BRAKE

DISTRONIC PLUS

Lane Tracking package

Intelligent Light System

COLLISION PREVENTION ASSIST

PRE-SAFE® system

Restraint systems

Mercedes-Benz emergency call system

Measures after an accident

40 **Multimedia systems**

COMAND Online

Audio 20 CD

Media Interface

Becker® MAP PILOT

Harman Kardon® Logic 7®

surround sound system

42 **Assistance systems**

Reversing camera

Active Parking Assist, including PARKTRONIC

Speed Limit Assist

44 **Variability**

Rear seats

Luggage compartment

EASY-VARIO-PLUS system

Load compartment package

46 **Seats and Memory package**

Seats

Seat Comfort package

4-way lumbar support for driver  
and front passenger

Memory package

47 **Light and Sight package**

**48 Equipment packages,  
incl. upholstery and trim**

Standard equipment  
Chrome package  
Sports package  
Night package  
Exclusive package

**66 Standard equipment****67 Optional extras****68 Wheels**

Standard wheels  
Optional wheels  
AMG wheels  
Accessory wheels

**70 Genuine accessories**

Rear Seat Entertainment System  
Concertina load sill guard  
Rear-mounted bicycle rack  
Roof boxes

**72 Services**

MercedesCard  
Mercedes-Benz Financial Services  
Mercedes-Benz mobility  
Mercedes-Benz Museum  
Test drive  
Interactive Owner's Manual and  
Mercedes-Benz Guides  
Mobile internet  
Service packages  
Accident repairs

**74 Dimensions****74 | 77 Paintwork****75 Technical data**



## BlueEFFICIENCY – fast forward to tomorrow

Mercedes-Benz is quicker at getting future technologies to where they matter most: on the road. With the exception of the G-Class and R-Class, all of our 4, 6 and 8-cylinder models now include BlueEFFICIENCY measures that help to reduce your impact on the environment significantly. Our BlueEFFICIENCY concept comprises innovations for efficient mobility as well as optimised processes all the way along the value chain.

**The BlueEFFICIENCY measures – the Mercedes-Benz efficiency package.** A comprehensive set of vehicle enhancements saves fuel and eases the burden on the environment. Each model combines the most efficient engine with the very latest aerodynamic and energy-management measures, including the ECO start/stop function available for most models. The BlueDIRECT V6 and V8 petrol engines featured in many model series deliver more power while reducing consumption by up to 25%. The new BlueEFFICIENCY Edition badge is reserved for the most economical models in selected ranges. These vehicles employ special measures to save weight, reduce air resistance or optimise the drivetrain and thereby achieve even lower fuel consumption and CO<sub>2</sub> figures.

**BlueTEC – the clean diesel.** A modular emission-control system makes BlueTEC an exceptionally clean diesel technology, as it not only removes up to 95% of the particulate matter from the exhaust gases but also reduces nitrogen oxides by up to 90%. What remains is mainly water and nitrogen.

**HYBRID – combustion engine and electric motor intelligently combined.** A well-coordinated team can achieve more, as hybrid technology certainly proves. The electric motor supports the engine during the journey – e.g. with a boost effect for more powerful acceleration – or it acts as a generator, recuperating energy during braking in order to charge the battery (regenerative braking). The latest-generation hybrid drive system is capable of all-electric operation for up to one kilometre at a maximum speed of 35 km/h and also allows efficient, emission-free coasting at speeds below 160 km/h by shutting off the engine on the overrun and disengaging the drive system. And for the first time, these benefits are also available in a premium-class diesel model – without any loss of spaciousness. The E 300 BlueTEC HYBRID<sup>1</sup> is also the world's most economical luxury-segment model.

**Innovative drive systems that break new ground.**

In mid-2013, our electric drive technology will be moving into the fast lane with the arrival of the SLS AMG Coupé Electric Drive<sup>2</sup>, which takes electric driving into a whole new dimension. This super sports car equipped with four synchronous electric motors is our second production-ready electric car and delivers superb performance figures: 551 kW and 1000 Nm make it the most powerful AMG high-performance model ever, yet it produces no local emissions. Another innovative alternative, the hydrogen drive, has also taken to the road at Mercedes-Benz with a small-scale series of B-Class models that use a fuel cell to generate power for the electric motor. Finally, the F 125! represents the future of zero-emission motoring in the luxury class.

But that's not all: under the banner "Design for Environment", we look at a vehicle's entire lifecycle and work hard to preserve the environment, all the way from the planning stage through to recycling. What's more, we are involved in the development of alternative fuels and carry out research in the field of bionics.

Further information about our comprehensive measures can be found at: [www.mercedes-benz.com/blueefficiency](http://www.mercedes-benz.com/blueefficiency)

<sup>1</sup> E-Class E 300 BlueTEC HYBRID Saloon: the vehicle complies with the Euro 5 emissions standard. Fuel consumption – urban: 4.3–4.2 l/100 km, extra-urban: 4.3–4.2 l/100 km, combined: 4.3–4.2 l/100 km; CO<sub>2</sub> emissions combined: 112–109 g/km

<sup>2</sup> SLS AMG Coupé Electric Drive – CO<sub>2</sub> emissions combined in g/km: 0; electrical consumption combined in kWh/100 km: 26.8 The figures shown were obtained in accordance with the prescribed measuring process (Directive [EC] 715/2007 in the currently applicable version).  
The figures are not based on an individual model and do not constitute part of the product offer; they are provided solely for purposes of comparison between different vehicle models

## B-Class BlueEFFICIENCY

The B-Class's holistic approach combines agility and dynamism with leading-edge efficiency technologies as well as innovative packages of measures aimed at optimising both fuel consumption and emissions



Every B-Class delivered is a BlueEFFICIENCY model. What's more, the International Environmental Certificate "Design for Environment" (ISO/TR 14062) attests to its high environmental compatibility, from production and usage right through to end-of-life disposal.

BlueEFFICIENCY comprises a whole package of specific measures:

- 1 Ancillary components controlled to save energy
- 2 Adjustable radiator shutter (B 180 BlueEFFICIENCY) and controlled oil pump
- 3 Particularly efficient alternator
- 4 Engines with direct petrol injection; optimised diesel engines
- 5 Refrigerant compressor characteristics
- 6 Optimised aerodynamics. 13% improvement over the predecessor model ( $c_d$  value = 0.26)
- 7 ECO start/stop function
- 8 Current fuel consumption indicator
- 9 All engines comply with the Euro 5 emission class
- 10 Tyres with reduced rolling resistance
- 11 7G-DCT dual clutch transmission (as an option)



## Diesel engines

Economical, clean, powerful: the B-Class also signals the launch of the latest Mercedes-Benz diesel technology. The powerful and quiet engines impress with their optimised emission and fuel consumption figures

**4-cylinder diesel engines.** The 4-cylinder diesel engine proves its up-to-the-minute qualities in all power ratings: it impresses with a hefty torque and its immediate response, even in the lower engine speed range. At the same time the diesel engines are modest when it comes to fuel consumption, are low on emissions, and boast significantly

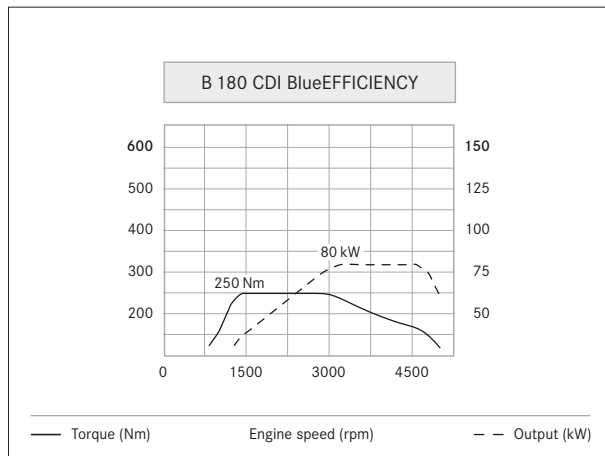

The B 180 CDI BlueEFFICIENCY achieves its peak torque of 250 Nm at between just 1400 and 2800 rpm

improved quiet-running characteristics and reduced vibrations. All this is possible thanks to a whole package of the latest technologies.

Measures such as tyres with low rolling resistance, intelligently controlled ancillaries and optimised aerodynamics all help to raise the efficiency of the vehicle as a whole sustainably. Yet this is by no means all: the current engine generation is characterised by its impressive output and high torque coupled with lower fuel consumption and reduced CO<sub>2</sub> emissions. All diesel engines are fitted as standard with the ECO start/stop function, which automatically switches the engine off when the vehicle is at traffic lights or in a jam. With the standard-fit ECO display the driver is informed about the efficiency of his or her driving style. The diesel engines are now available in three different power ratings:

– In the B 180 CDI BlueEFFICIENCY with 1796 cc and 80 kW (109 hp), plus a max. torque of 250 Nm

– In the B 200 CDI BlueEFFICIENCY with 1796 cc and 100 kW (136 hp), plus a max. torque of 300 Nm  
 – In the new B 220 CDI BlueEFFICIENCY with 2143 cc and 125 kW (170 hp), plus a max. torque of 350 Nm. This model already meets the requirements of the Euro 6 emission class



The advanced 4-cylinder diesel engine in the B 180 CDI BlueEFFICIENCY combines pulling power with low consumption and low emissions

## Petrol engines

The petrol engines were developed with the aim of substantially reducing fuel consumption and emissions without compromising on output and ride comfort.

The result: advanced, trendsetting engine technology

**4-cylinder in-line engines.** The 4-cylinder powerplant with direct petrol injection, variable valve timing and turbo-charger offers excellent torque and power and exemplary quiet-running characteristics, not to mention appropriately low fuel consumption and emissions. The high-pressure direct injection via precise piezo injectors and an enhanced

combustion process facilitate virtually total combustion and thus a higher efficiency factor, which means that the fuel goes further. And last but not least, the petrol models have the ECO start/stop function and ECO display fitted as standard. Both help the driver to reduce consumption even further. Over and above this, they include BlueEFFICIENCY measures such as thermal management for an engine warm-up phase that is kept as short as possible, an oil pump with on-demand control, plus a particularly efficient alternator. The 4-cylinder petrol engines come in three power ratings:

- In the B 180 BlueEFFICIENCY with 1595 cc and 90 kW (122 hp), plus a max. torque of 200 Nm
- In the B 200 BlueEFFICIENCY with 1595 cc and 115 kW (156 hp), plus a max. torque of 250 Nm
- In the B 250 BlueEFFICIENCY with 1991 cc and 155 kW (211 hp), plus a max. torque of 350 Nm

It goes without saying that all engines comply with the current limits for consumption and emissions (Euro 5).

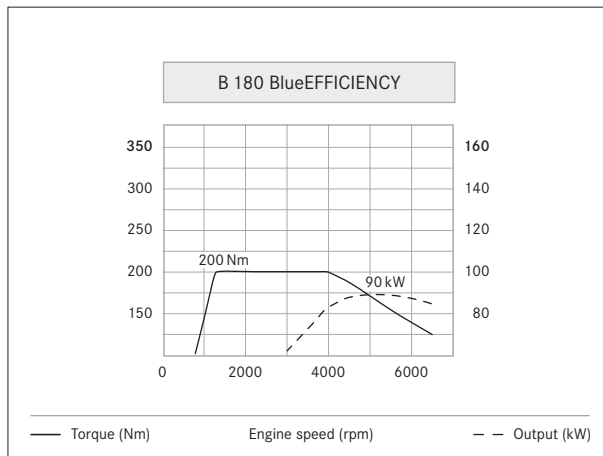

The B 180 BlueEFFICIENCY delivers a peak torque of 200 Nm between 1250 and 4000 rpm



The 4-cylinder B 180 BlueEFFICIENCY petrol engine boasts direct injection via piezo injectors and a turbocharger



## Natural Gas Drive. Alternative drive power

On our quest for emission-free mobility, we develop numerous technologies which are able to cut fuel consumption and lower CO<sub>2</sub> emissions. These include the Monovalent+ drive system in the B 200 Natural Gas Drive

**Natural Gas Drive.** The B 200 Natural Gas Drive is the first model to employ the new Monovalent+ drive. Natural gas provides the primary fuel source, with the small petrol tank only serving as a backup for extra range. This allows the

natural-gas drive's eco-friendly design and efficiency to be exploited to full effect. The gas tanks can be easily refilled via the tank recess behind the fuel filler flap. A natural-gas trip computer function in the instrument cluster helps the driver to gauge the remaining fuel range correctly: the B 200 Natural Gas Drive is capable of covering a distance of 500 km in natural-gas mode, which the petrol tank extends to an impressive total range of 720 km. Despite the addition of the gas bottles, boot capacity is unchanged compared to the base model.

It has the additional benefit of emitting around 16% less CO<sub>2</sub> in natural-gas mode than the combustion of an equivalent petrol fuel would. Fuel costs per 100 km are likewise lower for natural gas than for either diesel or petrol. So, you'll be reducing the burden on the environment – and on the family finances, too.

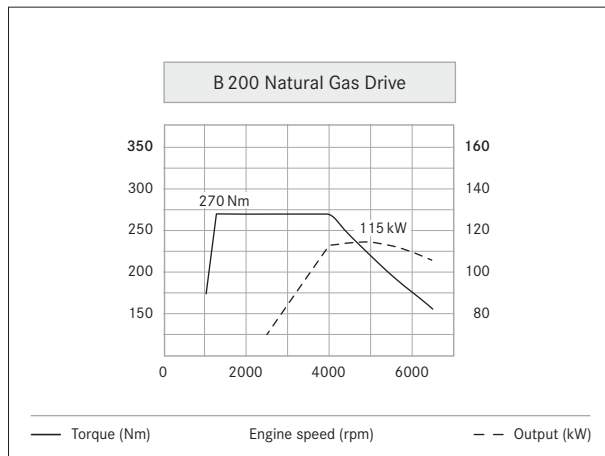

The B 200 Natural Gas Drive achieves its peak torque of 270 Nm at just 1250 rpm and maintains it all the way to 4000 rpm

The engine delivers impressive performance figures: 115 kW at 5000 rpm and 270 Nm from 1250–4000 rpm in both natural-gas and petrol mode. It is equipped as standard with the 6-speed manual transmission along with the ECO start/stop function that makes the Natural Gas Drive even more economical.



The gas tanks in the B 200 Natural Gas Drive are positioned in a space-saving arrangement underneath the seats. As a result, the boot capacity is just as large as that of the standard model



## Transmissions

Whether you choose the manual transmission or the 7G-DCT dual clutch transmission, whether you prefer an economical or sporty driving style – both transmissions for the B-Class are optimally matched to the engine. They impress with their shift comfort, efficiency and weight optimisation

**6-speed manual transmission.** All the engines<sup>1</sup> receive a 6-speed manual transmission and an ECO start/stop function as part of their standard specification. The ECO start/stop function ensures that the engine is temporarily switched off, for example at red traffic lights and in jams. The 6-speed manual transmission impresses with its short and precise shift travel, the engine output, gear spacing and final-drive ratio being optimally matched to each other. A display in the instrument cluster gives the driver gearshift recommendations, supporting a particularly efficient driving style.

**7-speed 7G-DCT dual clutch transmission (option).** With seven forward gears and one reverse gear, the dual clutch transmission combines comfort, sportiness and economy in unique fashion. It comprises two sub-transmissions which each have their own clutch, with one of these sub-transmissions supporting the “even” gears and the other sub-transmission the “odd” ones. During acceleration or braking the next highest or next lowest gear

is preselected on the sub-transmission not in use at the time. When changing gear there is then a switchover to the sub-transmission currently not being used. This means that the gear change takes place with practically no delay. Both clutch actuation and the gear change occur fully automatically, which facilitates particularly smooth gear shifting with virtually no interruption in power flow. The preselectable shift modes “Economy”, “Sport” and “Manual” can be set by the driver via a switch on the centre console. The modes differ from one another in terms of their shift characteristics and shift speed. This means that in “Sport” mode, changing up a gear takes place at higher engine speeds than is the case in “Economy” mode, whilst changing down a gear occurs earlier. The “Manual” mode gives sporty-minded drivers the option of performing gearshifts manually, either via the selector lever or the steering-wheel gearshift paddles which are included in the package too. There is also an integral ECO start/stop function which reduces fuel consumption. In addition an ergonomic DIRECT SELECT lever and the cruise control

and SPEEDTRONIC functions also form part of the specification with the 7G-DCT automated dual clutch transmission.



The 7G-DCT enables comfortable gear shifting with virtually no interruptions in power flow

<sup>1</sup> B 250 BlueEFFICIENCY with 7G-DCT dual clutch transmission as standard

## Chassis and suspension

The choice is yours: the B-Class is available with the standard chassis and steering configuration or with the optional combination of sports suspension and Direct-Steer system

**Chassis and steering.** Thanks to intelligent weight distribution, an optimised McPherson strut front axle and a specially designed four-link rear axle, the chassis developed for the B-Class facilitates maximum driving stability and ride comfort. The standard-fit rack-and-pinion steering with the integral STEER CONTROL steering assistance system for support in critical driving situations ensures precise

handling. The power assistance is delivered electromechanically and adapts in accordance with the car's speed.

**Sports suspension** (part of the optional Sports package). The sports suspension offers agility and high levels of handling safety yet keeps road roar and tyre vibration down. The springs and dampers have sportier, tauter tuning than

the standard-specification suspension, while the level of the car is 15 mm lower, which reduces rolling movements and increases driving stability.

**Direct-Steer system** (part of the optional Sports package). The Direct-Steer system forming part of the Sports package complements the suspension with a variable ratio depending on the steering wheel angle and thus ensures that the steering movements can implement an even more immediate response on the road. It significantly reduces the steering effort required, in tight bends, for instance, or when parking. The straight-line stability, meanwhile, is especially solid at high speeds and the feedback which the driver receives on the driving situation is particularly precise. In this way, the Direct-Steer system improves vehicle agility and steering comfort to deliver an even more enjoyable driving experience.

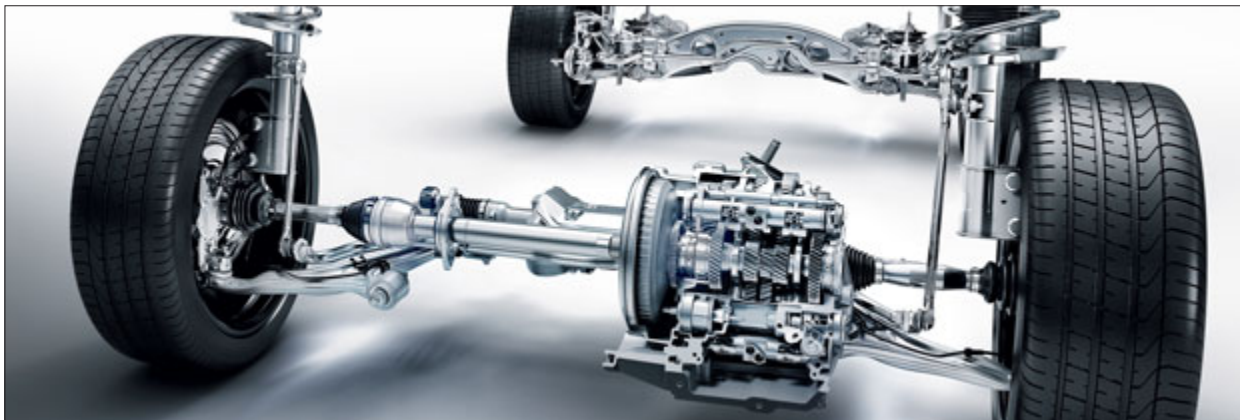

Agility coupled with high comfort – the sports suspension



## Integral safety concept

**We are driven by the vision of accident-free driving. Our integral safety concept – a comprehensive approach which can increase safety in every driving situation – brings us a step closer to making it a reality**

As the inventor of the motor car, we feel we have a special responsibility when it comes to road safety. This is why we are the first manufacturer to have developed an integral safety concept employing a seamless combination of active and passive safety measures to provide comprehensive protection. This integral approach is divided into four phases and offers safety solutions for every situation. These include systems for safe driving which can help the driver avoid hazards by providing a timely warning and assistance. Our unique PRE-SAFE® system is activated in the event of danger and triggers anticipatory measures to protect the occupants. If, despite these measures, an accident does occur, other technologies provide the appropriate degree of protection. We have also considered the time immediately after an accident and have developed solutions which can help to prevent a worsening of the situation and facilitate fast assistance.

A selection of these technologies for the “Safe driving”, “In the event of danger”, “In an accident” and “After an accident” phases is presented on the pages which follow.

**Safe driving: ATTENTION ASSIST** (standard). This innovative drowsiness-detection system can be especially useful on long trips. At speeds of between 80 and 180 km/h, ATTENTION ASSIST warns the driver as soon as it detects typical signs of drowsiness or inattention. This is made possible by sensors which analyse steering behaviour and can detect deviations from a previously determined, individual driver profile.



If ATTENTION ASSIST detects signs of driver drowsiness or inattention, it recommends taking a break

**Safe driving: ADAPTIVE BRAKE** (standard). A driving dynamics control system with a modular structure. It offers additional safety and comfort functions alongside a base function such as the anti-lock braking system (ABS). It improves the vehicle's performance with regard to traction, handling safety and operating comfort and helps the driver to master critical braking manoeuvres. The “dry braking” function helps to remove the film of water from the brake discs – the brakes' response time and therefore the stopping distance can thus be reduced. “Priming” ensures that the brake pads are placed against the brake discs as soon as the driver releases the accelerator pedal abruptly. The time gained shortens the response time of the brakes. When moving off on an incline, the vehicle is prevented from rolling back while the driver switches from the brake pedal to the accelerator. If you actuate the brake pedal a second time while the vehicle is stationary, the HOLD function keeps the vehicle at a standstill, even if you take your foot off the brake pedal.

**Safe driving: DISTRONIC PLUS** (option). The DISTRONIC PLUS proximity control uses state-of-the-art radar technology to register the situation in front of the car and maintain the desired safe distance to the vehicle in front. The system operates at between 0 and 200 km/h and in the range between 0.2 and 180 metres. This means that it is also helpful in city traffic or stop-and-go traffic. It can automatically brake the vehicle to a standstill and also accelerate it again. DISTRONIC PLUS is only available in conjunction with the optional 7-speed dual clutch transmission 7G-DCT.

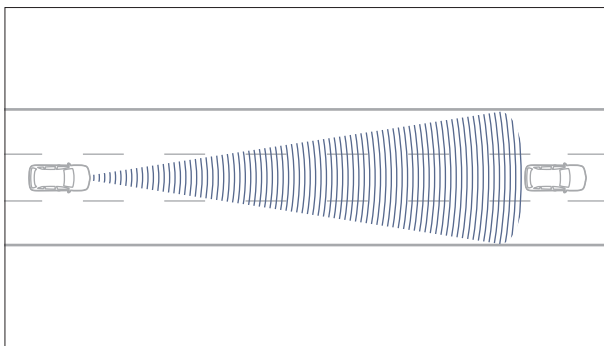

DISTRONIC PLUS can help drivers to automatically keep their vehicle at a safe distance from the vehicle in front

**Safe driving: Lane Tracking package** (option). With the aid of the white lane markings, Lane Keeping Assist is able to detect a lane and warn the driver – by making the steering wheel vibrate gently – if the car is in danger of leaving the lane unintentionally. Blind Spot Assist uses two radar sensors to monitor the area which can only be seen poorly by the driver directly alongside and behind the vehicle. If the assistance system detects the danger of an impending collision with another vehicle when changing lanes, the driver can be warned by both visual and acoustic signals if the car is travelling at 30 km/h or more.

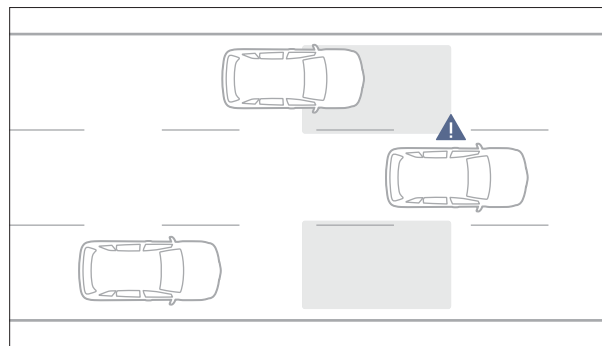

Blind Spot Assist monitors the area that is difficult for the driver to see at the right and left sides of the vehicle

**Safe driving: Intelligent Light System** (option). The system has six functions: country mode, motorway mode, enhanced fog lights, cornering light function, active light function and Adaptive Highbeam Assist. The latter provides the best possible low-beam headlamp range. The headlamps can be dimmed automatically as soon as an oncoming vehicle with its lights on is detected. The LED daytime running lamps with a chrome-look insert integrated into the bumper and the LED tail lights enhance perceptual safety at all times of the day.

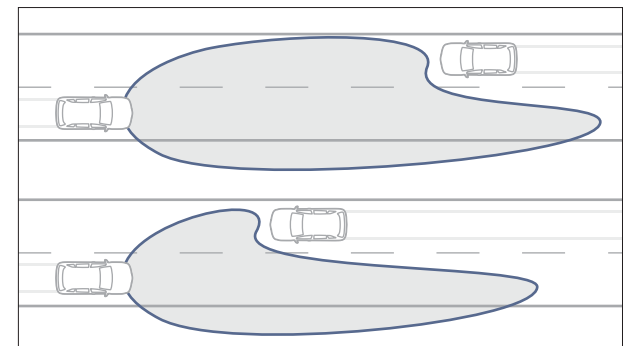

Adaptive Highbeam Assist detects other road users with their lights on and ensures the greatest possible range of vision



**In the event of danger: COLLISION PREVENTION ASSIST** (standard). At speeds of more than 30 km/h the system is able to detect when distances between the vehicle in which it is fitted and those in front or stationary obstacles are too short. If a hazard is detected the driver is given both visual and acoustic warnings. If the driver applies the brakes at the same time, Adaptive Brake Assist can place at the driver's disposal the precise amount of braking power calculated to offer the optimum scope for preventing an impending collision under ideal circumstances.

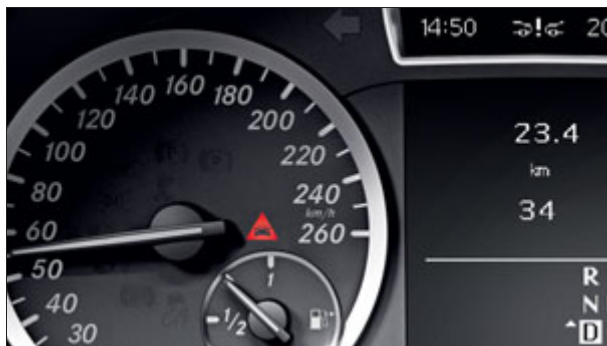

COLLISION PREVENTION ASSIST can provide visual and acoustic warnings if the safety margin is inadequate

**In the event of danger: PRE-SAFE® system** (option). The anticipatory occupant protection system PRE-SAFE® is able to recognise critical driving situations in advance and, if necessary, can activate safety systems which help to reduce the risk of injury to occupants as a precautionary measure. PRE-SAFE® works by continuously monitoring sensor data from systems like ESP® and BAS. This allows it, for example, to recognise driving situations such as oversteer/understeer as well as emergency braking. If a critical driving situation is detected, in fractions of a second the belts on the front seats can be reversibly tensioned and the

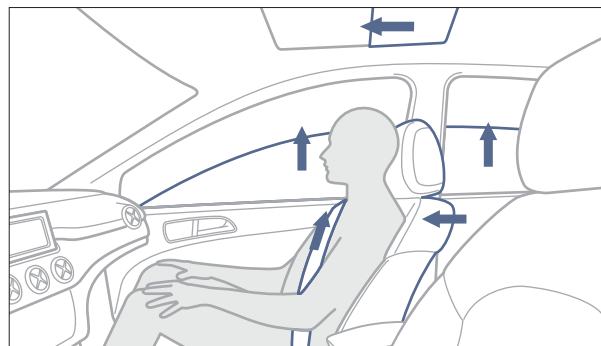

The PRE-SAFE® system can support the protective effect of seat belts and airbags

side windows and optional sliding sunroof automatically closed, so that the belts and airbags are able to deploy their full protective effect should an impact occur.

**In the event of an accident: restraint systems** (standard). Mercedes-Benz ensures that the 3-point seat belts, tensioners, belt force limiters and airbags are all coordinated optimally to minimise any injuries. In addition to the high-strength bodyshell structure and the highly stable occupant cell, seven standard-fit airbags contribute towards optimum protection of the vehicle occupants: front airbags, which can be deployed in two stages, depending on the impact severity and accident characteristics, windowbags between the A- and C-pillars and sidebags for the driver and front passenger. The kneebag can further reduce the forces exerted on the driver during an accident. Sidebags are available on the left and right in the rear as an optional extra. If the crash sensors detect an accident, the seat belts are automatically tensioned in an instant to secure the occupants in their seats. The belt force limiters, in turn, reduce the tension where appropriate in order to reduce the load on the thorax.

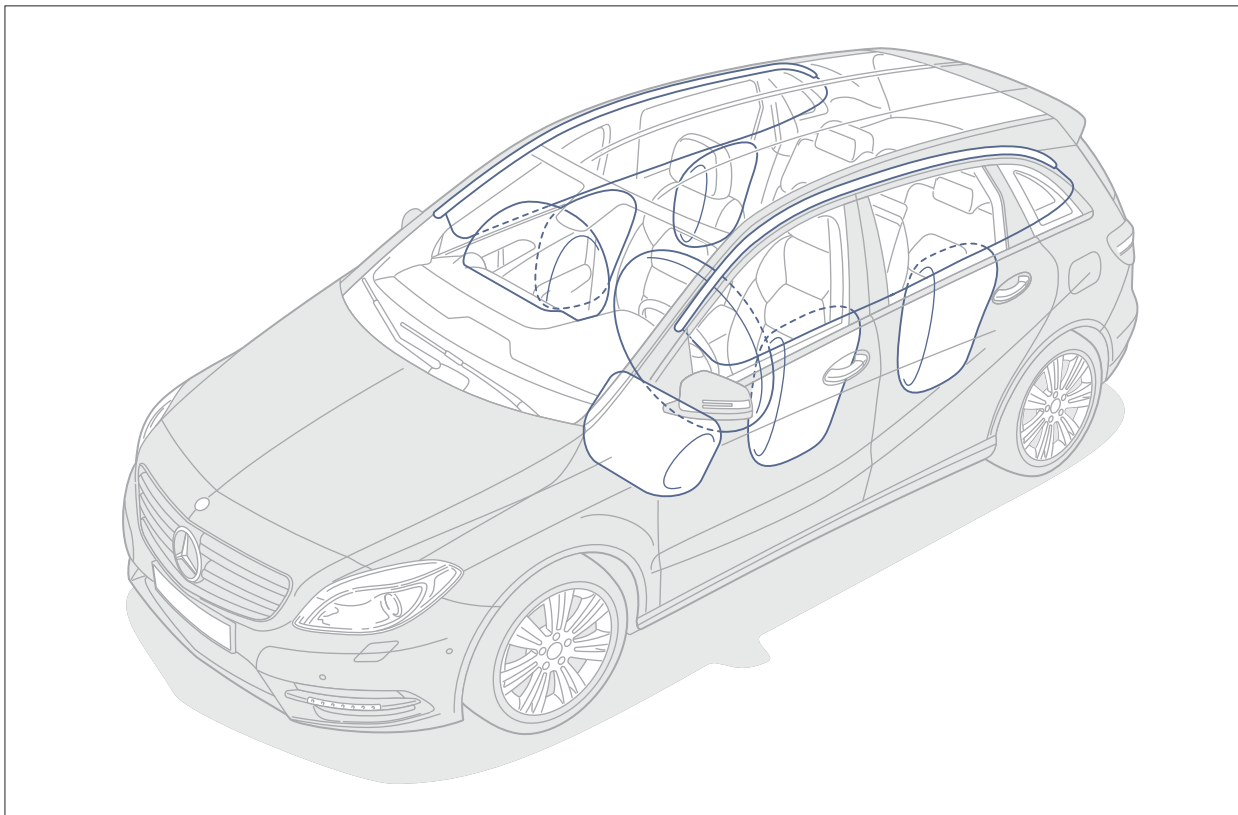

The seven airbags fitted as standard are part of the restraint systems which are decisive in helping to mitigate the consequences of accidents

**After an accident: Mercedes-Benz emergency call system** (component of COMAND Online). This system can make an emergency call automatically using a mobile phone which is operational and connected to the vehicle as soon as the restraint system detects an accident. At the same time, the GPS position data and other data about the vehicle are transmitted to the Mercedes-Benz emergency call centre, after which a voice connection is established.

**Measures after an accident.** To mitigate consequential damage and, if necessary, assist with occupant rescue, Mercedes-Benz has developed further measures such as automatic engine shut-off and activation of the hazard warning lights and emergency interior lighting. The central locking unlocks automatically too, making it easier to open the doors after an accident. Furthermore, the multilingual Mercedes-Benz Guidelines for Rescue Services can be accessed online (at [www.mercedes-benz.de/rettungsleitfaden](http://www.mercedes-benz.de/rettungsleitfaden)) and downloaded for use by emergency services all over the world. As you can see, Mercedes-Benz has a well thought-out safety concept for every situation.

## Multimedia systems

The B-Class offers a full range of entertainment systems, from the Audio 20 CD and the optional Audio 20 CD system with Becker® MAP PILOT to the optional COMAND Online multimedia system



COMAND Online facilitates user-friendly operation of the main information and communication functions via a single, high-resolution colour display with a diagonal of 17.8 cm

**COMAND Online** (option). The multimedia system boasts a high-resolution 17.8 cm colour display. The system's functions include a radio, speed-sensitive volume control, the MUSIC REGISTER with a 10 GB hard disc and hard-disc navigation. What's more, for three years from the initial registration it also includes free updates for European map data. The DVD drive plays CDs and MP3 files as well as video and audio DVDs. The online function with an integral browser facilitates access to the internet plus various mobile services from Mercedes-Benz via an internet-capable mobile phone. A USB and an Aux-in socket, a slot for SD memory cards and a Bluetooth® interface enable connections to external data carriers and a mobile phone. The system is operated via a Controller that can be used intuitively and also via the buttons on the multifunction steering wheel. LINGUATRONIC allows you to operate COMAND Online by voice entry.



**Audio 20 CD** (standard). Audio 20 CD ensures that you have an entertaining journey. The Mercedes-Benz multimedia system boasts a display with TFT technology and a 14.7 cm diagonal. With its integral CD drive both MP3 and WMA/AAC files can be played. As an option, a 6-disc CD changer can be added to its specification. Audio 20 CD can be conveniently operated via the multifunction steering wheel and the Controller in the centre console, and it includes an integral telephone keypad, a Bluetooth® interface with a hands-free function and an Aux-in and USB socket in the stowage compartment on the centre console. This means that you can easily play music that you have saved on an MP3 player, smartphone or mobile data carrier, for instance. Six loudspeakers bring you a pristine listening experience perfectly tuned to the vehicle's interior.

**Media Interface** (option). The improved Media Interface is perfectly matched to mobile audio devices such as the Apple iPod®: tracks are changed and displayed quickly, the device's folder structure is adopted and the music transmitted digitally.

**Becker® MAP PILOT** (option). Fully integrated, the Becker® MAP PILOT with 3D map navigation can be operated using voice entry, the Controller or the multifunction steering wheel. It can be individualised in next to no time by downloading current map data and additional functions. A cradle for the control unit in the glove compartment allows the system to be used flexibly and removed from the vehicle.



The functions provided by the Becker® MAP PILOT are indicated on the Audio 20 CD display and the multifunction display in the instrument cluster

**Harman Kardon® Logic 7® surround sound system** (option). Experience sound that is as realistic, atmospheric and rich in detail as a live performance. With twelve loudspeakers, including a woofer, and a 9-channel DSP amplifier, in conjunction with COMAND Online the 450-watt Dolby Digital 5.1 system ensures an exquisite listening experience. The surround sound playback can be individually tuned to the entire passenger compartment, the front compartment, the centre area or the rear compartment.



The Harman Kardon® Logic 7® surround sound system impresses with its surround sound specially tuned to the interior of the B-Class

## Assistance systems

Alongside numerous safety systems, various comfort assistance systems are available for the B-Class, too. They can provide timely warnings of potentially critical situations and so help the driver to avoid dangers

**Reversing camera** (option). The reversing camera with a wide-angle lens and guide lines provides additional support for the driver by monitoring the area directly behind the car and sending the images to the screen of the Audio 20 CD (or the optional COMAND Online display). It is activated when reverse gear is engaged, thus enhancing safety when reversing into a parking space.



During parking, the COMAND Online central display shows the area behind the car

**Active Parking Assist, including PARKTRONIC** (option). With Active Parking Assist from Mercedes-Benz the vehicle looks for a suitable parking space by itself at a speed of up to 35 km/h. As soon as the driver confirms a suggestion for a parking space and engages reverse gear, Active Parking Assist automatically parks the car at the press of a button. The driver then only needs to actuate the gearshift, the accelerator and brake pedal. Active Parking Assist deals with the steering on its own. The improved system now works



The display in the instrument cluster gives you a clear picture of what is happening during the current parking manoeuvre

even more precisely: for the automatic parking procedure the parking space has to be just one metre longer than the vehicle. And entering parking spaces on bends has also been optimised. The vehicle can steer automatically when exiting parking spaces too. The driver only needs to operate the accelerator and brake pedal and pay attention to the traffic. The function for exiting a parking space is activated via the button on the steering wheel after starting the engine and putting the indicator on. The system then asks whether the vehicle should automatically exit the parking space. The Active Parking Assist system uses a total of ten ultrasonic sensors, six in the front and four in the rear bumper, plus there is an electronic control unit which processes the sensor signals and calculates the optimum route into the parking space.

**Speed Limit Assist** (included with the optional extra COMAND Online). This assistance system can detect speed-limit signs using a windscreen camera and navigation data and display the appropriate symbol in the display on the instrument cluster. If the applicable speed limit changes,

the display in the instrument cluster is amended accordingly. To this end, the camera monitors the area in front of the car on a permanent basis and filters out round traffic signs, be they speed-limit signs at the side of the road or on a gantry above the road. To detect the signs, the system also scans the data stored on the navigation system's digital map, thus also enabling the identification and display of the signs seen when entering or leaving some towns and villages. Speed Limit Assist is especially useful on routes with variable speed limits or road works, where it can help the driver to stay within the stipulated limit. In this way, it makes a tangible contribution towards improving comfort on long journeys when the speed limits are frequently changing.



Speed Limit Assist can remind the driver about the speed limit currently in force



## Variability

The rear seats and luggage compartment are configured to meet a whole host of requirements, making a major contribution to the B-Class's variability and flexibility

**Rear seats.** Even in standard guise, the rear compartment impresses with the generous amount of legroom it offers. As part of the standard specification the rear seats come with three head restraints, with the centre head restraint restricting the rearward vision as little as possible. ISOFIX child seat attachments with TopTether securing points are fitted to the backrests of the outer seats. As an optional extra the two outer rear seats are available with integral child seats and a removable lateral support headrest.



The interior can be transformed into a virtually flat load area in just a few simple steps

**Luggage compartment.** If required the rear seat backrests can be folded in a ratio of 1/3 : 2/3, producing up to 1547 litres of load space and a 1.57-metre-long, virtually flat load compartment area. When using the B-Class as a 5-seater, the load compartment capacity is 488 litres, and the load compartment floor is adjustable to two levels in conjunction with the optional load compartment package. These functions are rounded off by other practical features: a load compartment cover plus bag hooks and four load retainers for securing luggage.



In the upper position the optionally available height-adjustable load compartment floor contains a generous stowage compartment

**EASY-VARIO-PLUS system** (option). The separate fore/aft adjustment functionality of the rear seat elements and the tilt angle adjustment of the rear seat backrests ensure more kneeroom or an enlarged load compartment, depending on requirements. The rear is also equipped with a folding armrest which includes a through-loading feature, plus two cup holders and a folding front passenger backrest – and it can all be operated quickly and easily.

**Load compartment package** (no-cost option in conjunction with the EASY-VARIO-PLUS system). This comprises a load compartment floor whose height can be adjusted to two levels, enabling the load compartment to be adapted to the respective load situation. In addition to the other stowage features, a folding box ensures more order and safety in the load compartment, which also includes a socket (12 V). Plus there is an optional net to form a luggage compartment partition behind the first or second seat row, providing increased occupant protection and reducing the risk of transport damage.



Fully folding down the rear seats produces a load compartment capacity of 1547 litres with a practically flat load area

## Seats and Memory package

Modular seats that meet an exceptionally wide range of requirements in terms of ergonomic design, seating comfort and safety have been developed for the B-Class

**Seats** (standard). The seats for the B-Class boast high levels of seating comfort for the front and rear occupants, offering a generous amount of space for their legs and shoulders. The driver's seat is height adjustable as standard, for optimum adaptation to body size. The modern interior with the high-quality appeal of its materials sports a uniform look in black Venlo fabric, and there are also other colours available to please various tastes in conjunction with a range of optional packages, including seat covers in Domburg fabric, a combination in ARTICO man-made leather/Den Helder fabric, plus upholstery in ARTICO or fine leather all over.

**Seat Comfort package** (option). This also comprises height adjustment for the front passenger seat plus seat cushion inclination adjustment for both front seats. Numerous possibilities for ergonomic individualisation and adjustment to the preferred seat position equal yet more seating comfort – above all on longer journeys. The seats with the Seat Comfort package are also characterised by a special seat cushion design.

**4-way lumbar support for the driver and front passenger** (option). The backrest curvature can be individually adjusted to meet the needs of the driver and front passenger, promoting an ergonomic seating position. Two air cushions are integrated in the backrests of both front seats. Via two control valves they can be inflated or deflated as required, facilitating individually tailored support for the lumbar region. The height of the air cushions is also adjustable.



The comfortable front seats in the B-Class impress with their ergonomics and wide-ranging adjustment options

**Memory package** (option). As an option the driver's seat can be continuously adjusted electrically. The Memory package can store three individual settings for the position of the driver's seat, head restraint and exterior mirrors. With this feature all the seat and backrest settings, the head restraint height and exterior mirror position on the driver's and front-passenger side can be called up at any time at just one push of a button, and the front-passenger mirror automatically lowers when reverse gear is engaged.



The Memory package with its fully electrically adjustable driver's seat stores up to three individual settings



## Light and Sight package

The optionally available Light and Sight package highlights the interior design to practical and stylish effect in equal measure, providing a shining example of the comfort and safety standards offered by the B-Class

**Light and Sight package** (option). The Light and Sight package enhances safety and improves the driver's perception of the traffic – an invaluable benefit in particular during darkness or in poor weather conditions. The package comprises safety-relevant features such as windscreen wipers fitted with a rain sensor and an enlarged washer fluid reservoir, exit and warning lamps for the driver's and front-passenger door, plus a warning and ambient lamp for the tailgate. Quite apart from the safety aspects, the package also increases the high perceived value of the interior. The

integral ambient lighting in the trim on the dashboard as well as in the door handle recesses and door pulls also lends the interior design of the B-Class a stylish and exclusive touch. This pleasant overall impression is enhanced by sun visors with an illuminated vanity mirror, footwell lighting, separately controllable reading lamps on both the left and right-hand side in the rear – and, last but not least, by a downlighter for the rear compartment. The Light and Sight package can also include illuminated door sill panels for the driver's and front-passenger door as an option.



In darkness the ambient lighting adds stylish emphasis to the interior



The warning and ambient lighting in the tailgate

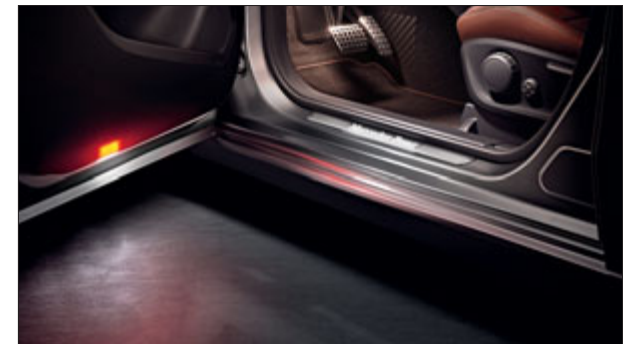

The footwell illumination, the exit and warning lighting and the optional illuminated door sill panel at the front



The illustration shows optional extras: metallic paintwork, 10-spoke light-alloy wheels and front fog lamps

## Standard equipment

Luxury is there to be enjoyed every day. Not only is the B-Class generously designed; it also impresses with its high functionality and suitability for everyday use plus a modern interior featuring materials with high-quality appeal. The standard specification includes the Audio 20 CD with Bluetooth®, a USB interface and an Aux-in socket, plus the Controller on the centre console. The standard-fit air conditioning also makes an important contribution towards a good atmosphere on board at all times. Innovative assistance systems such as COLLISION PREVENTION ASSIST and ATTENTION ASSIST round off the extensive range of standard equipment.

---

### Exterior

---

Headlamp Assist with automatically activated headlamps

---

Heated exterior mirrors, electrically adjustable from inside, finished in the vehicle colour, with integral indicators

---

LED daytime running lamps, circular

### Interior

---

12-button three-spoke multifunction steering wheel

---

Armrest in front

---

Chrome designer key

---

ECO start/stop function

---

Electric parking brake

---

Power windows (4)

---

Trim in silver chrome

---

Trip computer in the multifunction display

---







The seat covers come with Venlo fabric in black as standard. ARTICO man-made leather or Domburg fabric are available as an option, for which there are two upholstery colours each (three in the case of ARTICO man-made leather). The rest of the interior boasts a coordinated colour scheme, in a combination of lava black with a black carpet. The trim sports a modern matrix-look and can also be selected in finely grained satin-finish brown burr walnut wood or high-gloss black ash.

---

#### Venlo fabric

---

001 black

---

#### Domburg fabric (option)

---

011 black

018 crystal grey

---

#### ARTICO man-made leather (option)

---

101 black

105 sahara beige

108 crystal grey

---

#### Trim

---

736 High-gloss black ash wood (option)

H03 Satin-finish brown burr walnut wood (option)

H88 Matrix-look

---

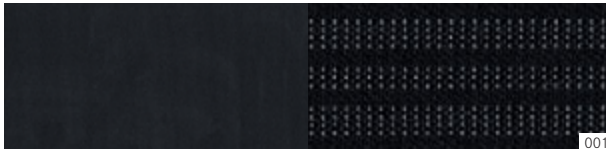

001

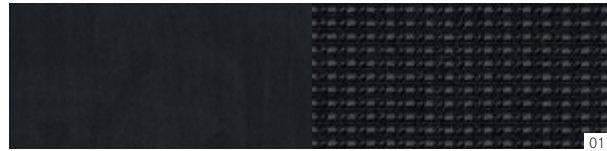

011



101



105

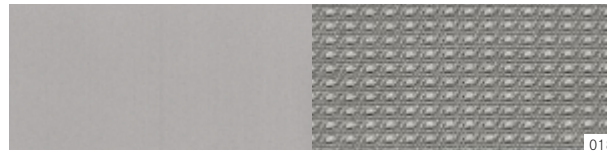

018



108



736



736



736



H03



H03



H03



H88



H88



H88



The illustration shows optional extras: metallic paintwork, 7-twin-spoke light-alloy wheels and bi-xenon headlights



## Chrome package

Available as an option, the Chrome package enhances the vehicle's stylish appeal with some individual highlights. On the exterior the radiator grille trim in brilliant silver and the side trim plus the surround on the daytime running lamps are shining examples in chrome. Interior details such as the rotary light switch with a chrome surround lend the B-Class a decidedly high-quality character.

### Exterior

Daytime running lamps, circular with chrome surrounds

Front and rear bumpers with chrome trim, rear bumper with black grained insert

Load sill guard in chrome-look finish

Radiator grille with three louvres in brilliant silver with chrome trim

Shoulderline trim strip in chrome

### Interior

12 V socket in the rear

Air outlets with surround and cruciform nozzle in silver chrome

Controller on the centre console with chrome surround

Door and centre console armrests with topstitching

High-gloss rotary light switch with chrome surround

Load compartment floor handle in chromed die-cast zinc

Matrix-look trim

Shift/selector lever with highlights in silver chrome

Sun visors illuminated with vanity mirror



The upper illustration shows the optional extras THERMOTRONIC automatic climate control and seats in ARTICO man-made leather  
The lower illustration shows the optional extras metallic paintwork and 7-twin-spoke light-alloy wheels



The standard upholstery in Venlo fabric comes in black. The covers are also available in black and in crystal grey Domburg fabric as an option and also in sahara beige ARTICO man-made leather. The trim is available in a matrix-look or, as an option, in finely grained satin-finish brown burr walnut wood or high-gloss black ash. The shift lever, air vents and controls are adorned with trim in fine chrome. With the crystal grey and sahara beige upholstery colours, sections of the armrests between the front seats and the door centre panels are in a two-tone contrasting look with black. The rest of the interior is in lava black.

---

#### Venlo fabric

001 black

---

#### Domburg fabric (option)

011 black

018 crystal grey

---

#### ARTICO man-made leather (option)

101 black

105 sahara beige

108 crystal grey

---

#### Trim

736 High-gloss black ash wood (option)

H03 Satin-finish brown burr walnut wood (option)

H88 Matrix-look

---



001

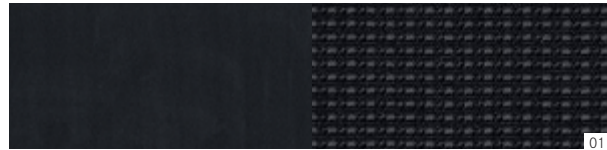

011



101



105

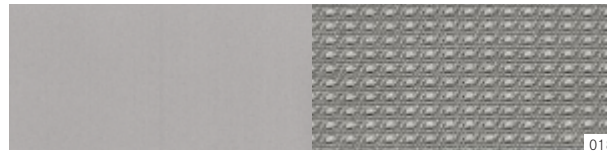

018



108



736



736



736



H03



H03



H03



H88



H88



H88





The illustration shows the optional bi-xenon headlamps

## Sports package

Driving enjoyment even at a standstill – the decidedly more dynamic and athletic look which comes courtesy of the Sports package, coupled with increased agility, is evident in the exclusive appointments and equipment features, a greater degree of individualisation plus special technical highlights. The contents of the Chrome package are already contained in the Sports package.

### Exterior

5-spoke light-alloy wheels with 225/45 R 17 tyres

Lowered sports suspension<sup>1</sup> and Direct-Steer system

Perforated and internally ventilated front brake discs, front brake callipers with “Mercedes-Benz” lettering

Radiator grille with twin louvres in brilliant silver with chrome trim

Two-pipe exhaust system with tailpipe in polished stainless steel

### Interior

3-spoke multifunction sports steering wheel in perforated leather

Armrest in ARTICO man-made leather with topstitching on centre console, adjustable lengthwise

Honeycomb-look trim

Roof lining in black, deselectable

Seat Comfort package

Seats upholstered in ARTICO man-made leather/Den Helder fabric with contrasting topstitching

Shift/selecter lever in leather with highlights in chrome

Stainless steel door sill panels, front and rear

Stainless-steel-look sports pedals with rubber studs



<sup>1</sup> Can be deselected for comfort suspension

The upper illustration shows optional extras: COMAND Online multimedia system, THERMOTRONIC automatic climate control and the 7G-DCT automated dual clutch transmission  
The lower illustration shows the two-pipe exhaust system with tailpipes in polished stainless steel



The Sports package adds a particularly dynamic touch to the interior, too. The seat covers can be selected in the combination ARTICO man-made leather/Den Helder fabric in black or crystal grey, and as an option they are also available in black, sahara beige or crystal grey ARTICO man-made leather all over. The upholstery colours are in ARTICO man-made leather on the door centre panels and armrests. The dashboard with chrome trim is discreetly coordinated with the chosen interior colour in a tone-in-tone look. The rest of the interior is colour-matched in a combination of lava black with a lava black carpet. The trim boasts a honeycomb-look, and as an option it is also available in satin-finish brown burr walnut wood or high-gloss black ash. The steering wheel trimmed in perforated leather is adorned with contrasting topstitching. The roof liner in black can also be deselected as a further option.

---

**ARTICO man-made leather/Den Helder fabric**

---

601 black

608 crystal grey

---

**ARTICO man-made leather (option)**

---

101 black

105 sahara beige

108 crystal grey

---

**Trim**

---

736 High-gloss black ash wood (option)

H03 Satin-finish brown burr walnut wood (option)

H89 Honeycomb-look

---





601



101



105



608



108



736



736



H03



H03



H89



H89



The illustration shows the optional bi-xenon headlamps

## Night package

The Night package is sure to make a cool impression in any situation: with its selected exterior equipment and appointments the package lends the vehicle a distinctive and intriguing character in classy high-gloss black, while the interior corresponds to the scope of the Sports package. The heat-insulating dark-tinted glass for the rear window and rear side windows is also unique, giving prying eyes the cold shoulder. The Night package is only available in conjunction with the Sports package and bi-xenon headlamps.

---

### Exterior

5-twin-spoke light-alloy wheels, painted black and with a high-sheen finish, with 225/40 R 18 tyres (mandatory in conjunction with Night package)

Bi-xenon headlamps (mandatory in conjunction with the Night package)

Bumper without chrome trim

Heat-insulating dark-tinted glass for the rear and rear side windows (from B-pillar)

Radiator grille with twin louvres in high-gloss black with chrome trim

Shoulderline and roof trim strip in high-gloss black

Two-pipe exhaust system with tailpipe in polished stainless steel

### Interior

Equipment as for Interior Sports package

---



The illustration above shows optional extras: COMAND Online multimedia system and THERMOTRONIC automatic climate control





The seat covers can be selected in ARTICO man-made leather/Den Helder fabric in black or crystal grey. The covers are also available in black, sahara beige and crystal grey ARTICO man-made leather. The upholstery colours are sported on the door centre panels and also on the armrest between the front seats (armrest in black where ARTICO man-made leather upholstery in sahara beige is specified). The rest of the interior is colour-matched in lava black. The trim boasts a sporty honeycomb-look, and is also optionally available in satin-finish brown burr walnut wood or high-gloss black ash.

---

**ARTICO man-made leather/Den Helder fabric**

---

601 black

608 crystal grey

---

**ARTICO man-made leather (option)**

---

101 black

105 sahara beige

108 crystal grey

---

**Trim**

---

736 High-gloss black ash wood (option)

H03 Satin-finish brown burr walnut wood (option)

H89 Honeycomb-look

---





The illustration above shows optional extras: COMAND Online multimedia system, THERMOTRONIC automatic climate control and the 7G-DCT automated dual clutch transmission



## Exclusive package

The optional Exclusive package represents a classic interior with the highest level of quality, combined with numerous exclusive appointments and equipment features, the like of which are traditionally found in luxury-segment vehicles. The Exclusive package is available on the basis of the Chrome, Sports or Night package and offers various options for individualisation.

---

### Interior

---

3-spoke leather steering wheel with 12 function buttons

---

Armrest on the centre console in ARTICO man-made leather with topstitching, adjustable lengthwise

---

Dashboard and door centre panels in ARTICO man-made leather with topstitching

---

Door armrests in ARTICO man-made leather with topstitching

---

Extended central locking with infrared remote control

---

Front seats with 4-way lumbar support

---

Headlining in black (hazelnut brown upholstery)

---

Headlining in grey (lava black, crystal grey upholstery)

---

Heated front seats

---

High-gloss black ash wood trim as no-cost option

---

Seat Comfort package

---

Seats upholstered in leather with topstitching

---

Shift/selecter lever and gaiter in leather and chrome surround for shift/selecter lever

---

Stainless steel door sill panels, front and rear

---

Stowage compartment cover in black-painted plastic

---

Velour floor mats with edging in appointments colour

---

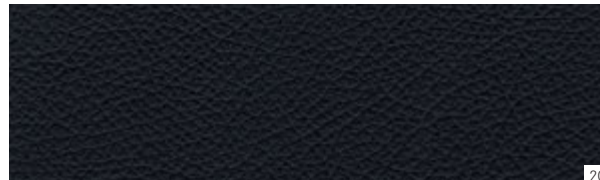

201

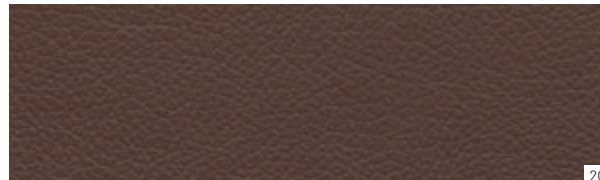

204

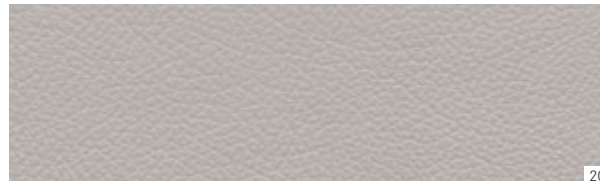

208



736



H03

Enjoying pride of place in the Exclusive package, the seat upholstery in fine leather is available in the colours lava black, hazelnut brown or crystal grey. The selected upholstery colours are also to be found on the door centre panels and on the armrest between the front seats, and in the case of the interior colour crystal grey also on the underside of the dashboard and on the centre console. The dashboard with its chrome trim on the ventilation outlets, controls and shift lever is discreetly coordinated with the chosen interior colour in a tone-in-tone look. The rest of the interior is colour-matched in lava black with floor mats featuring tone-in-tone edging. The trim is in finely grained satin-matt brown burr walnut wood and is optionally available in fine high-gloss black ash wood.

---

### Leather

---

201 lava black

204 hazelnut brown

208 crystal grey

---

### Trim

---

736 High-gloss black ash wood (option)

H03 Satin-finish brown burr walnut wood

---

## Standard equipment | Selection



Multifunction steering wheel



Audio 20 CD



Integral aerial



Power windows for all four doors



THERMATIC air conditioning



Luggage compartment cover

## Optional extras | Selection



Ambient lighting



Reversing camera



Convenience Telephony



Becker® MAP PILOT



THERMOTRONIC automatic climate control



Trailer coupling, manually folding



## Wheels



Steel wheels with 10-hole wheel trim with 195/65 R 15 tyres (standard for B 180 CDI BlueEFFICIENCY and B 180 BlueEFFICIENCY), Code R00



10-spoke light-alloy wheels with 205/55 R 16 tyres (optional, not available for Sports package or Night package), Code 55R



7-twin-spoke light-alloy wheels with 205/55 R 16 tyres (only for B 200 Natural Gas Drive), Code R27



7-twin-spoke light-alloy wheels with 225/45 R 17 tyres (optional, not available for Night package), Code 26R



Steel wheels with 10-hole wheel trim with 205/55 R 16 tyres (standard for B 200 CDI BlueEFFICIENCY, B 220 CDI BlueEFFICIENCY and B 200 BlueEFFICIENCY, not available for Sports package or Night package), Code 643



Multi-spoke light-alloy wheels with 225/55 R 17 tyres (only for B 200 Natural Gas Drive), Code 08R



10-spoke light-alloy wheels with 225/45 R 17 tyres (optional, standard for B 250 BlueEFFICIENCY, not available for Night package), Code R43



5-spoke light-alloy wheels with 225/45 R 17 tyres (part of Sports package, not available for Night package), Code R24



5-twin-spoke light-alloy wheels, painted tremolite grey, with 225/45 R 17 tyres (optional, not in conjunction with Night package), Code 44R



AMG 5-twin-spoke light-alloy wheels, painted black with a high-sheen finish, with 225/40 R 18 tyres, Code 781



AMG multi-spoke light-alloy wheels, painted black with a high-sheen rim flange, with 225/40 R 18 tyres, Code 646



5-twin-spoke light-alloy wheels<sup>1</sup>, painted champion silver, with 205/55 R 16 tyres (genuine accessory, not available for Night package)



5-twin-spoke light-alloy wheels, painted black with a high-sheen finish, with 225/40 R 18 tyres (optional, part of Night package), Code 01R



AMG multi-spoke light-alloy wheels, painted titanium grey with a high-sheen finish, with 225/40 R 18 tyres (not in conjunction with Night package), Code 791



AMG 5-twin-spoke light-alloy wheels, painted titanium grey with a high-sheen finish, with 225/40 R 18 tyres (not in conjunction with Night package), Code 794



5-twin-spoke light-alloy wheels<sup>1</sup>, painted himalayas grey, with 225/45 R 17 tyres (genuine accessory, not available for Night package)

<sup>1</sup> Genuine accessory wheels are supplied without tyres

## Genuine accessories

Practical, diverse, flexible – the genuine accessories open up a wealth of possibilities for getting even more out of the B-Class

→ [www.mercedes-benz-accessories.com](http://www.mercedes-benz-accessories.com)



The Rear Seat Entertainment System with its two crystal-sharp LCD colour screens promises top in-car entertainment for the rear

**Rear Seat Entertainment System.** The elegant DVD system puts your DVD videos, favourite pictures and even video games on two crystal-sharp 17.8 cm LCD colour screens, without disturbing the driver or restricting their field of vision to the rear. One of the monitors is fitted with a DVD player and a USB/SD card interface, thus facilitating the use of lots of other storage media as well as DVDs. The second screen serves as a display monitor. Both can be very easily removed from their holder with just one click and with the 230 V/12 V power supply unit which is included they can also be used outside the vehicle.

The extensive equipment includes USB and SD card interfaces, two infrared headphones and radio remote control. The monitors are also available individually as an option. The Rear Seat Entertainment System requires no pre-installation at the factory, allowing it to be retrofitted in your B-Class.



**Concertina load sill guard.** Loading and unloading the B-Class is a relaxed affair with the concertina load sill guard made of durable nylon fabric. This component can be attached simply and in a space-saving manner on the floor behind the load compartment sill with Velcro fasteners. The load sill guard is extendable in one simple step to provide extensive protection for the load compartment sill and rear bumper.



The concertina load sill guard protects the rear bumper and the load compartment sill against scratches when loading and unloading

**Rear-mounted bicycle rack.** Convenient, lockable rear-mounted bicycle rack for transporting two or three bicycles safely. Fitting it on the trailer coupling is child's play, and mounting your bikes on the rack is just as easy. Thanks to a clever roll-off mechanism the luggage compartment can still be opened. A transport bag made of robust nylon fabric protects your rear-mounted bicycle rack when you want to fold it up and store it for a while.



The foldable rear-mounted bicycle rack for the trailer coupling is available in two versions

**Roof boxes.** The roof boxes have an aerodynamic design perfectly matched to the B-Class and are made of an extremely durable material. Thanks to the option of opening on both sides they are particularly easy to load and unload. Select from two sizes: the family box in black metallic or matt silver offers 450 litres of capacity, the sports box in titanium metallic or matt silver 330 litres.



The roof boxes are available with a capacity of 330 and 450 litres, and two different colours each

## Services

**MercedesCard.** As a VISA credit card, this is an internationally accepted means of payment that can offer you a host of additional benefits, such as the Mercedes-Benz insurance package or other exclusive insurance products. There's also the Mercedes-Benz magazine to inspire you with its fascinating features and reports. Further details are available from your Mercedes-Benz dealer.

**Mercedes-Benz Financial Services.** Mercedes-Benz stands for quality, innovation and safety – and the same applies to Mercedes-Benz Financial Services. Our innovative leasing and financing products are tailored to your financial needs and means, making it easy for you to secure the keys to your dream car. Once you are on the road, our insurance products offer you comprehensive protection on every trip. Finally, our service products ensure that your car is always in tip-top condition while keeping costs transparent and easily manageable. For a detailed quotation, please contact your authorised Mercedes-Benz dealer, who will be pleased to go through the latest financial services and terms and conditions with you.

**Mercedes-Benz mobility.** Your new car comes complete with the promise of feeling safe on the road. But if you should ever need assistance, Mercedes-Benz Service24h is there to help. Just call the freephone service hotline on 00800 1 777 7777<sup>1</sup>. The integrated telematics service, Mercedes-Benz Contact<sup>2</sup>, is even more convenient: a touch of a button is all it takes to contact the Mercedes-Benz customer centre. If you wish, relevant vehicle and position-related data are transmitted at the same time, thereby allowing the centre to react quickly and provide rapid on-site assistance. Also standard with your new car at no extra charge is the Mercedes-Benz Mobilo<sup>3</sup> mobility package. Whether you have lost your key, had a breakdown which cannot be repaired immediately or suffered damage to the vehicle due to an accident or vandalism, Mobilo helps you reach your destination – anywhere in Europe. Whatever is holding you up, you will soon be able to resume your journey.

**Mercedes-Benz Museum.** Discover what has been moving the world for over 125 years, and embark on a fascinating journey through automotive history in the Mercedes-Benz Museum. More than 1500 exhibits covering an area of 16,500 square metres chart the unique heritage and innovative flair of the inventor of the motor car. From the very

first model through to the very latest, you will find one legendary car after another awaiting you. The museum is a spectacular sight in its own right too, thanks to an architecture that breaks away from traditional concepts and creates an unprecedented sense of space. Welcome to the Mercedes-Benz Museum – a world of innovation. [www.mercedes-benz-classic.com/museum](http://www.mercedes-benz-classic.com/museum)

**Test drive.** The unique feeling of driving a Mercedes cannot be put into words – you have to experience it for yourself. Take a test drive and find out first hand how it feels to drive your dream car. Please contact your nearest Mercedes-Benz dealer for details.



<sup>1</sup> Alternative: +49 69 95 30 72 77 <sup>2</sup> Requires a factory-fitted radio, connected to an operational mobile phone. The only charge incurred is the cost of the mobile phone call to the landline network <sup>3</sup> Once the mobility guarantee has expired (four years), Mobilo can be extended to provide cover in the event of breakdown and insurance claims one year at a time for a maximum of 30 years, provided that regular maintenance is carried out by your Mercedes-Benz service partner

**Interactive Owner's Manual and Mercedes-Benz Guides.**

The website also offers an interactive tour, enabling you to acquaint yourself with your dream car. You can view key functions in detail, gain an insight into the car's inner workings or look at the benefits of each model. For further details, go to [www.mercedes-benz.de/owners-manual](http://www.mercedes-benz.de/owners-manual). The "Mercedes-Benz Guides" app lets you explore the highlights of the individual models both online and offline. The app is available free of charge from the Apple® iTunes® Store (iOS) as well as the Google Play store (Android).

**Mobile internet.** The entire world of Mercedes-Benz can be accessed at any time with your web-capable mobile device - including specially adapted content for both smartphones and tablets. As well as an overview of all the passenger car models, there are insights into the entire brand world along with a wealth of entertainment offers and direct links to our range of services at [www.mercedes-benz.com](http://www.mercedes-benz.com)

**Mercedes-Benz service contracts.** Vehicle-specific service contracts allow you to arrange individual cover for your Mercedes: for a small monthly premium, the Excellent service contract covers all service jobs including maintenance, wear and repairs for up to five years. Simply present your service card and you will be safe from any unwelcome financial surprises - and you can relax in the knowledge that your Mercedes will stay on top form for a long time to come. The Advance service contract provides a warranty extension, so you will be protected against unexpected repair costs even after the manufacturer's warranty or the Excellent service contract has expired - for up to ten years.



**Accident repairs.** Should the worst happen and you find yourself in need of repairs, with the Mercedes-Benz accident repair service you will receive the best possible assistance for your vehicle and ensure that its high-quality safety features are properly maintained. Whether you need paint, body or glass repair work carried out, the highly trained specialists at your Mercedes-Benz service partner will repair your Mercedes-Benz and get you quickly back on the road again. Further information is available from your authorised Mercedes-Benz dealer.





## Dimensions

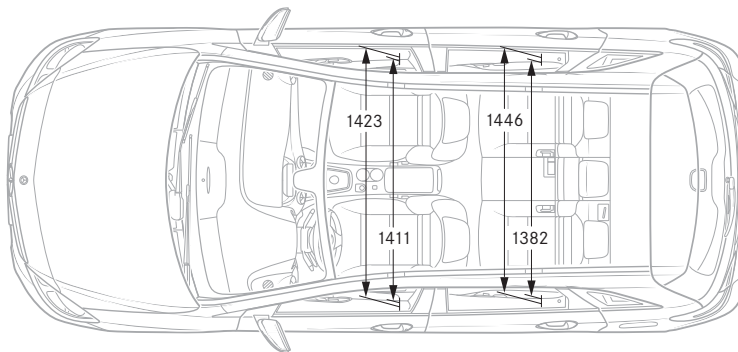
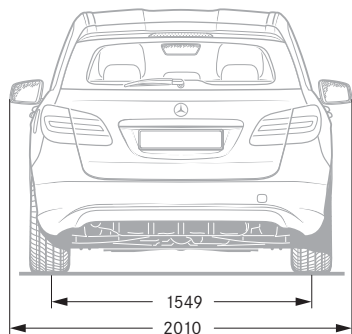
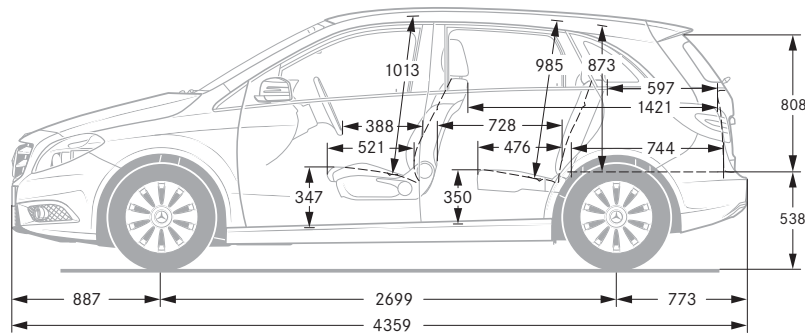
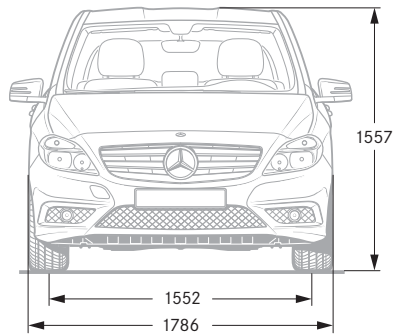

## Paintwork

The innovative paint system developed by Mercedes-Benz includes one of the best clearcoats on the automotive market and is a key factor behind the car's excellent value retention. The secret lies in the exceptionally dense molecular structure, which makes both the metallic and the non-metallic clearcoats more resistant and produces a longer-lasting and visibly more intensive shine.

### Non-metallic paints (standard)

- 589 jupiter red
- 650 cirrus white
- 696 night black

### Metallic paints (option)

- 162 south seas blue
- 191 cosmos black
- 761 polar silver
- 787 mountain grey
- 893 monolith grey
- 894 universe blue
- 895 canyon beige

# Technical data

No. of cylinders/arrangement
Total displacement in cc
Rated output <sup>1</sup> in kW (hp) at rpm
Rated torque <sup>1</sup> in Nm at rpm
Acceleration from 0–100 km/h in s [7G-DCT]
Top speed, approx. in km/h
Tyre size, front
Tyre size, rear
Fuel
Fuel consumption <sup>2</sup> in l/100 km
Urban [7G-DCT]
Extra-urban [7G-DCT]
Combined [7G-DCT]
CO <sub>2</sub> emissions <sup>2</sup> in g/km combined [7G-DCT]
Emission class
Tank capacity in l/of which reserve, approx.
Boot capacity in l
Turning circle diameter in m
Kerb weight <sup>3</sup> in kg [7G-DCT]
Perm. GVW in kg [7G-DCT]

## Diesel engines

B 180 CDI BlueEFFICIENCY	B 200 CDI BlueEFFICIENCY	B 220 CDI BlueEFFICIENCY
4/in-line	4/in-line	4/in-line
1796	1796	2143
80 (109)/3200–4600	100 (136)/3600–4400	125 (170)/3400–4000
250/1400–2800	300/1600–3000	350/1400–3400
10.9 [10.7]	9.5 [9.3]	– [8.3]
190	210	– [220]
195/65 R 15	205/55 R 16	205/55 R 16
195/65 R 15	205/55 R 16	205/55 R 16
Diesel fuel	Diesel fuel	Diesel fuel
5.6–5.4 [5.1–4.9]	5.6–5.4 [5.2–5.0]	– [5.6–5.4]
4.1–3.8 [4.2–3.9]	4.1–3.8 [4.2–4.0]	– [4.0–3.8]
4.6–4.4 [4.5–4.2]	4.6–4.4 [4.5–4.2]	– [4.6–4.4]
121–114 [121–113]	121–115 [121–114]	– [120–114]
Euro 5	Euro 5	Euro 6
50/6.0	50/6.0	50/6.0
488–1547	488–1547	488–1547
11.0	11.0	11.0
1475 [1505]	1475 [1505]	– [1500]
2030 [2025]	2030 [2025]	– [2020]

Figures in square brackets apply to engines in conjunction with optional 7G-DCT 7-speed dual clutch transmission

<sup>1</sup> Figures in accordance with Directive 80/1269/EEC in the currently applicable version <sup>2</sup> The figures shown were obtained in accordance with the prescribed measuring process (Directive [EC] 715/2007 in the currently applicable version in each case).  
<sup>3</sup> The figures are not based on an individual model and do not constitute part of the product offer; they are provided solely for purposes of comparison between different vehicle models

	<b>Petrol engines</b>			
	B 180 BlueEFFICIENCY	B 200 BlueEFFICIENCY	B 250 BlueEFFICIENCY	B 200 Natural Gas Drive
No. of cylinders/arrangement	4/in-line	4/in-line	4/in-line	4/in-line
Total displacement in cc	1595	1595	1991	1991
Rated output <sup>1</sup> in kW (hp) at rpm	90 (122)/5000	115 (156)/5300	155 (211)/5500	115 (156)/5000
Rated torque <sup>1</sup> in Nm at rpm	200/1250-4000	250/1250-4000	350/1250-4000	270/1250-4000
Acceleration from 0-100 km/h in s [7G-DCT]	10.4 [10.2]	8.6 [8.4]	- [6.8]	9.2 [9.1]
Top speed, approx. in km/h	190	220	- [240]	200
Tyre size, front	195/65 R 15	205/55 R 16	225/45 R 17	205/55 R 16
Tyre size, rear	195/65 R 15	205/55 R 16	225/45 R 17	205/55 R 16
Fuel	Premium petrol	Premium petrol	Premium petrol	Natural gas/Premium petrol
Fuel consumption <sup>2</sup> in l/100 km				
Urban [7G-DCT]	8.3-8.0 [7.6-7.6]	8.3-8.0 [7.6-7.6]	- [8.8-8.6]	6.0-6.0 [5.7-5.6] <sup>4</sup>
Extra-urban [7G-DCT]	5.0-4.7 [5.0-4.8]	5.0-4.7 [5.0-4.8]	- [4.9-4.7]	3.4-3.3 [3.4-3.4] <sup>4</sup>
Combined [7G-DCT]	6.2-5.9 [5.9-5.8]	6.2-5.9 [5.9-5.8]	- [6.3-6.2]	4.4-4.3 [4.3-4.2] <sup>4</sup>
CO <sub>2</sub> emissions <sup>2</sup> in g/km combined [7G-DCT]	144-137 [139-135]	144-138 [139-136]	- [147-145]	119-117 [117-115]
Emission class	Euro 6	Euro 6	Euro 6	Euro 6
Tank capacity in l/of which reserve, approx.	50/6.0	50/6.0	50/6.0	21 kg/3.0 kg (Nat.gas), 12/6.0 (Prem.petrol)
Boot capacity in l	488-1547	488-1547	488-1547	488-1547
Turning circle diameter in m	11.0	11.0	11.0	11.0
Kerb weight <sup>3</sup> in kg [7G-DCT]	1395 [1425]	1395 [1425]	- [1475]	1535
Perm. GVW in kg [7G-DCT]	1960 [1950]	1960 [1950]	- [2000]	2050

<sup>3</sup> Figures according to Directive 92/21/EC, version 95/48/EC (kerb weight with fuel tank 90% full, driver, 68 kg, and luggage, 7 kg) for standard-specification vehicles. Optional extras and accessories will generally increase this figure and reduce the payload capacity accordingly

<sup>4</sup> Figures apply to operation in natural-gas mode only and are shown in kilograms per 100 km Further technical data can be found at [www.mercedes-benz.com](http://www.mercedes-benz.com)



Non-metallic paints

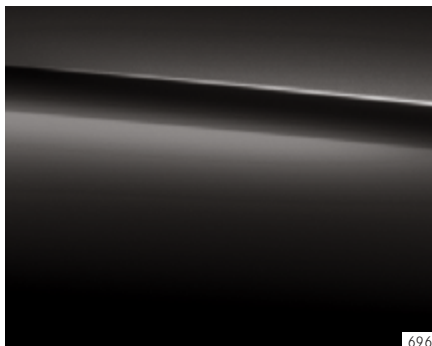
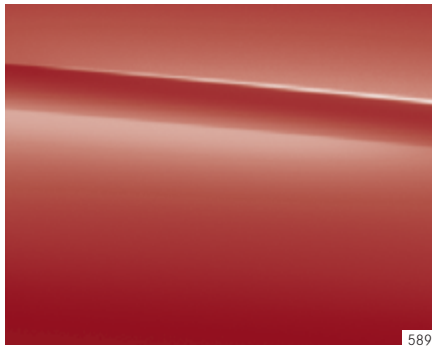

Metallic paints

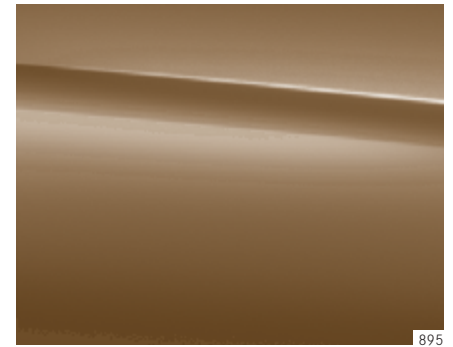
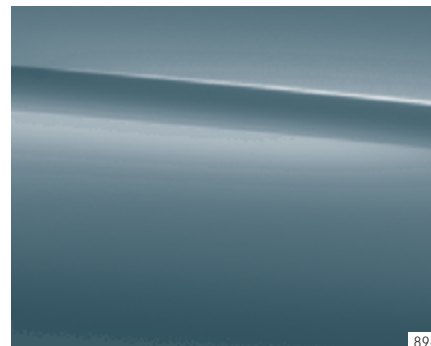
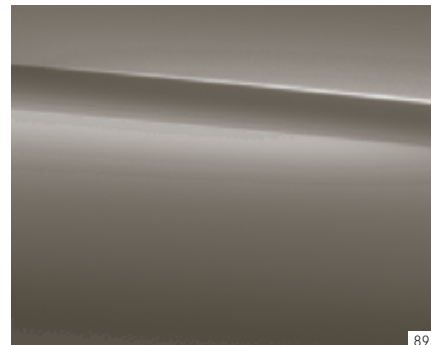
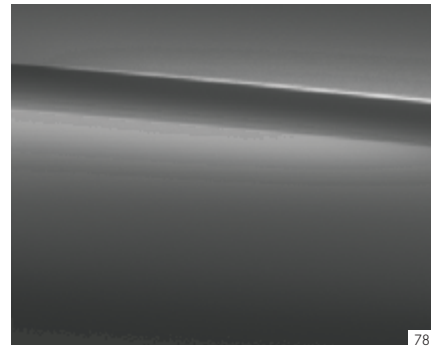
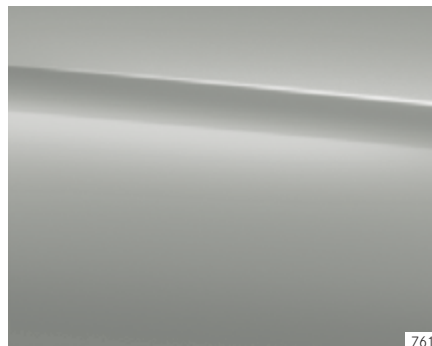
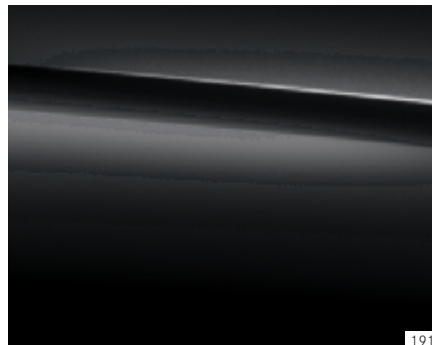
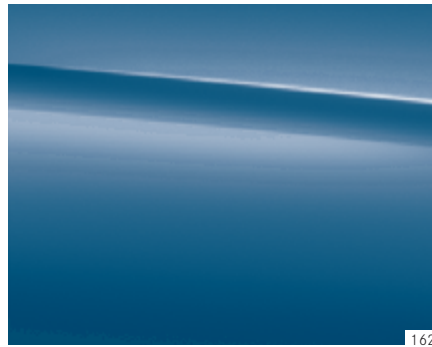

**Take-back of end-of-life vehicles.** You can return your B-Class to us for environment-friendly disposal in accordance with the European Union (EU) End-Of-Life Vehicle Directive. But that day lies a long way off.

A network of vehicle take-back depots and dismantlers has been established to make it as easy as possible for you to return your vehicle. You can leave it at any of these points free of charge and, by doing so, make an important contribution to completing the recycling process and conserving resources.

For further information about the recycling and disposal of end-of-life vehicles, and the take-back conditions, please visit the national Mercedes-Benz website.

**Please note:** changes may have been made to the product since this brochure went to press (11.07.2012). The manufacturer reserves the right to make changes to the design, form, colour and specification during the delivery period, provided these changes, while taking into account the interests of the vendor, can be deemed reasonable with respect to the purchaser. Where the vendor or the manufacturer uses symbols or numbers to describe an order or the subject of an order, no rights may be derived solely from these. The illustrations may show accessories and items of optional equipment which are not part of standard specification. Colours may differ slightly from those shown in the brochure, owing to the limitations of the printing process. This brochure is distributed internationally. It provides a general indication of the range of models, features, optional extras and/or colours available in various countries. Some of the models, features, optional extras and/or colours shown may not be available in your country or may only be available in a different specification. Additionally some models, features, optional extras and/or colours may only be available in combination with others. For current and more specific information in relation to the range of models, features, optional extras and/or colours available in your country, and their pricing, you should contact your nearest authorised Mercedes-Benz Passenger Car Dealer.

**[www.mercedes-benz.com](http://www.mercedes-benz.com)**