

This Brochure is prepared by Daimler AG and it predominantly reflects the capabilities and performance of vehicles sold in Europe. Some characteristics, capabilities, performance features and optional extras (e.g. towing systems) may not be available or may not apply in Australia or under Australian conditions. The information in this Brochure is therefore indicative, illustrative and provided only for guidance and should not be relied on. To obtain current and accurate information on a vehicle and any options applicable to Australia, contact your local authorised Mercedes-Benz dealer.



Mercedes-Benz

# The CLA-Class



Mercedes-Benz





# Untamed. The new CLA

Say goodbye to the old visual conventions: the new CLA breaks all the rules – not just those governing the traditional concept of beauty. The proud radiator grille, the profile charged with energy and the honed spoiler lip combine to create an exceptional form with breathtakingly low wind resistance. Engine technology refined and concentrated to the maximum allows the new CLA to reconcile effortlessly superior performance with restrained fuel consumption. The interior also breaks with the conventional idea of a coupé with sporty, contrasting appointments and avantgarde design options. The new CLA sets out to challenge received ideas of taste and design. Is it a challenge you're ready to take up?

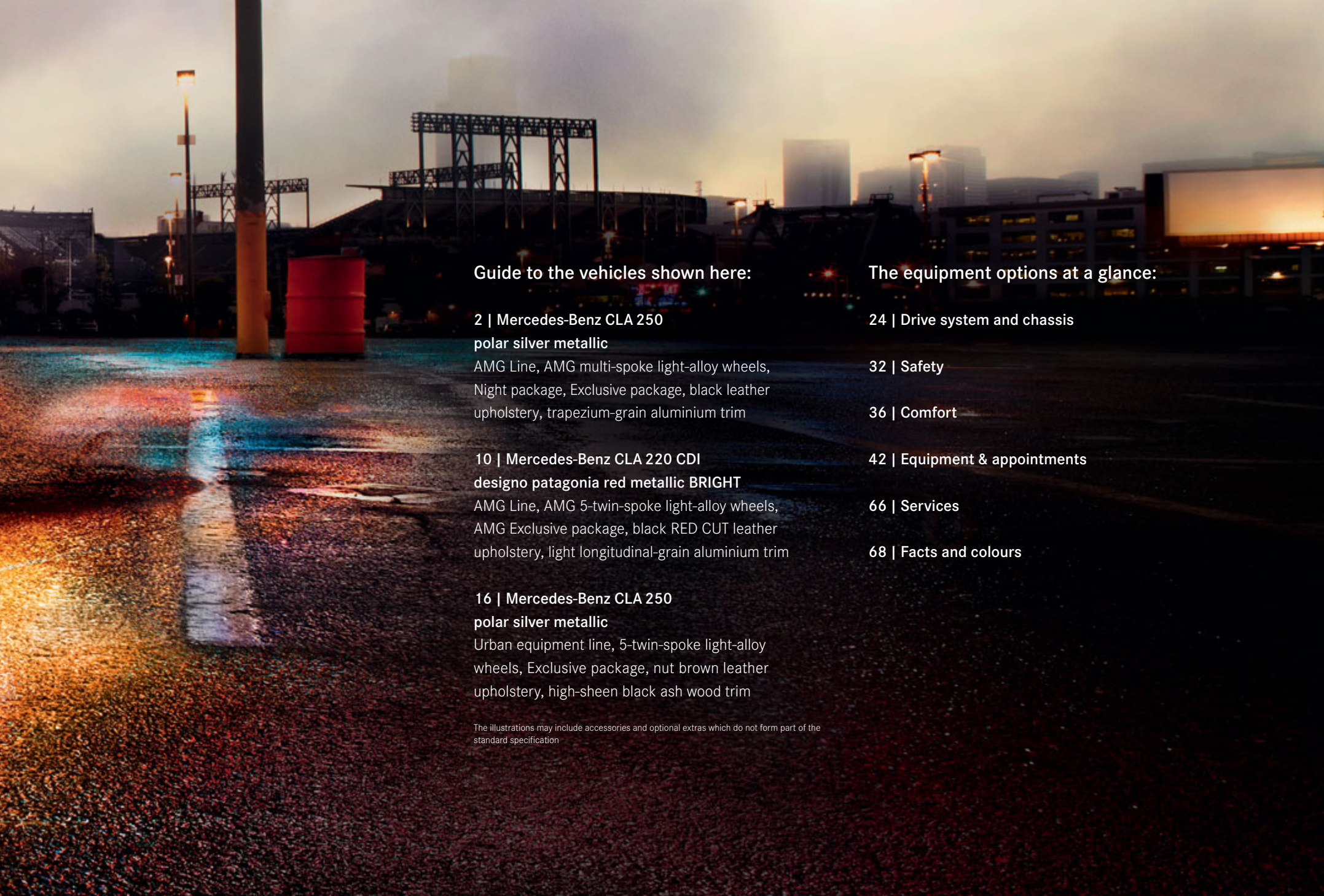

## Guide to the vehicles shown here:

### 2 | Mercedes-Benz CLA 250

#### polar silver metallic

AMG Line, AMG multi-spoke light-alloy wheels, Night package, Exclusive package, black leather upholstery, trapezium-grain aluminium trim

### 10 | Mercedes-Benz CLA 220 CDI

#### designo patagonia red metallic BRIGHT

AMG Line, AMG 5-twin-spoke light-alloy wheels, AMG Exclusive package, black RED CUT leather upholstery, light longitudinal-grain aluminium trim

### 16 | Mercedes-Benz CLA 250

#### polar silver metallic

Urban equipment line, 5-twin-spoke light-alloy wheels, Exclusive package, nut brown leather upholstery, high-sheen black ash wood trim

The illustrations may include accessories and optional extras which do not form part of the standard specification

## The equipment options at a glance:

### 24 | Drive system and chassis

### 32 | Safety

### 36 | Comfort

### 42 | Equipment & appointments

### 66 | Services

### 68 | Facts and colours

2

A pioneer doesn't go with the flow - it breaks new ground



No sooner has the new CLA attracted your attention than it breaks your resistance. Its flowing lines give visual expression to its exemplary aerodynamics. In fact, its flow resistance is so low that it sets new standards for series-production vehicles. The avantgarde design evokes movement even when the vehicle is stationary.







## Design: a declaration of independence

The coupé-like roof line, frameless windows and high beltline create a strong profile which flows into the muscular tail end. Not everyone will appreciate such expressive details, but those who do will understand that they are the consequence of the uncompromising pursuit of the CLA design philosophy. Even when that means going against the flow.

## Turns four cylinders into an arrow

Radical change requires energy. In the new CLA, highly concentrated engine technology extracts maximum power from the line-up of four-cylinder units. A standard-fit 6-speed manual transmission or an optional 7-speed dual clutch transmission deliver this output straight to the road.



The image shows the interior of a car, focusing on the front seats. The seats are upholstered in black leather with white stitching. The car is parked at night, and the view through the window shows a cityscape with lights and buildings. The interior is dimly lit, with a focus on the texture of the leather and the stitching.

The interior also exerts a powerful fascination, not least thanks to the integral-look sports seats which are standard in both the front and the rear. The design of the air nozzles recalls the form of a jet engine while the red illumination of the twin-tube instrument cluster adds to the ambience. Equally striking is the large, free-standing display with TFT technology which can show content from your iPhone® and forms a high-speed interface to the digital world.



## Statement of intent



No colour has a more powerful effect than red. Naturally this finish is also included in the scope of the AMG Line. The diamond radiator grille makes a similarly dominant statement while the front and rear aprons and side skirts with their AMG bodystyling create a profile which underlines the vehicle's coupé character. A two-pipe exhaust system completes the dynamic ensemble.



## Takes a strong line



Leading, not following: the sports suspension included in the AMG Line package lowers the body and so literally brings you closer to the road. The reduced ride height is complemented by the firmer damper setup and the Direct-Steer system which ensures that your steering inputs are met with an immediate and precise response.









An avantgarde exterior naturally raises expectations about the interior appointments. The choice of perforated leather in black and red underlines the sportiness of the seats. Contrasting topstitching – which extends to the steering wheel with its particularly satisfying grip characteristics – gives the interior a hand-crafted look and feel.



Controlled, not tamed





There is one area in which the new CLA will always shun confrontation and play it safe. The protection offered by the high structural strength of its body and its array of up to nine airbags is complemented by innovative assistance and safety systems which can intervene when required. COLLISION PREVENTION ASSIST, ADAPTIVE BRAKE with the HOLD function as well as ATTENTION ASSIST are fitted as standard. One thing you won't require any assistance with is your enjoyment of the driving experience.



## Sculpted by the wind: the world champion for aerodynamics

The wind changes from southerly to north-easterly. Speed: 140 km/h. A star stands firm against the onslaught of the air masses as an engineer's hand moves over the fine lines on the bonnet, causing one of them to change to a much more vivid colour. The gale-force wind is now blowing from dead ahead. Yet it is strangely quiet – as, indeed, it always is when a storm is raging in the Mercedes-Benz lab. Here, in the virtual wind tunnel, the new CLA demonstrating its aerodynamic qualities is a sophisticated digital model – just like the air flows that buffet it.

It takes time and a great deal of meticulous work to develop good aerodynamics. Every component generates results which have to be included, calculated precisely, optimised to offer the best air flow and applied to the vehicle as a whole. In the case of the new CLA, for example, special comb-shaped spoilers in the wheel arches subdue the air flows around the wheels. Every reduction of one thousandth in wind resistance pays: with a higher speed and lower fuel consumption. Even a 0.01 reduction in wind resistance represents a saving of 0.1 litres per 100 kilometres. Or, to put it another way: 230,000 hours in the virtual wind tunnel and plenty of painstaking work have made the new CLA the world champion in the field of aerodynamic efficiency.



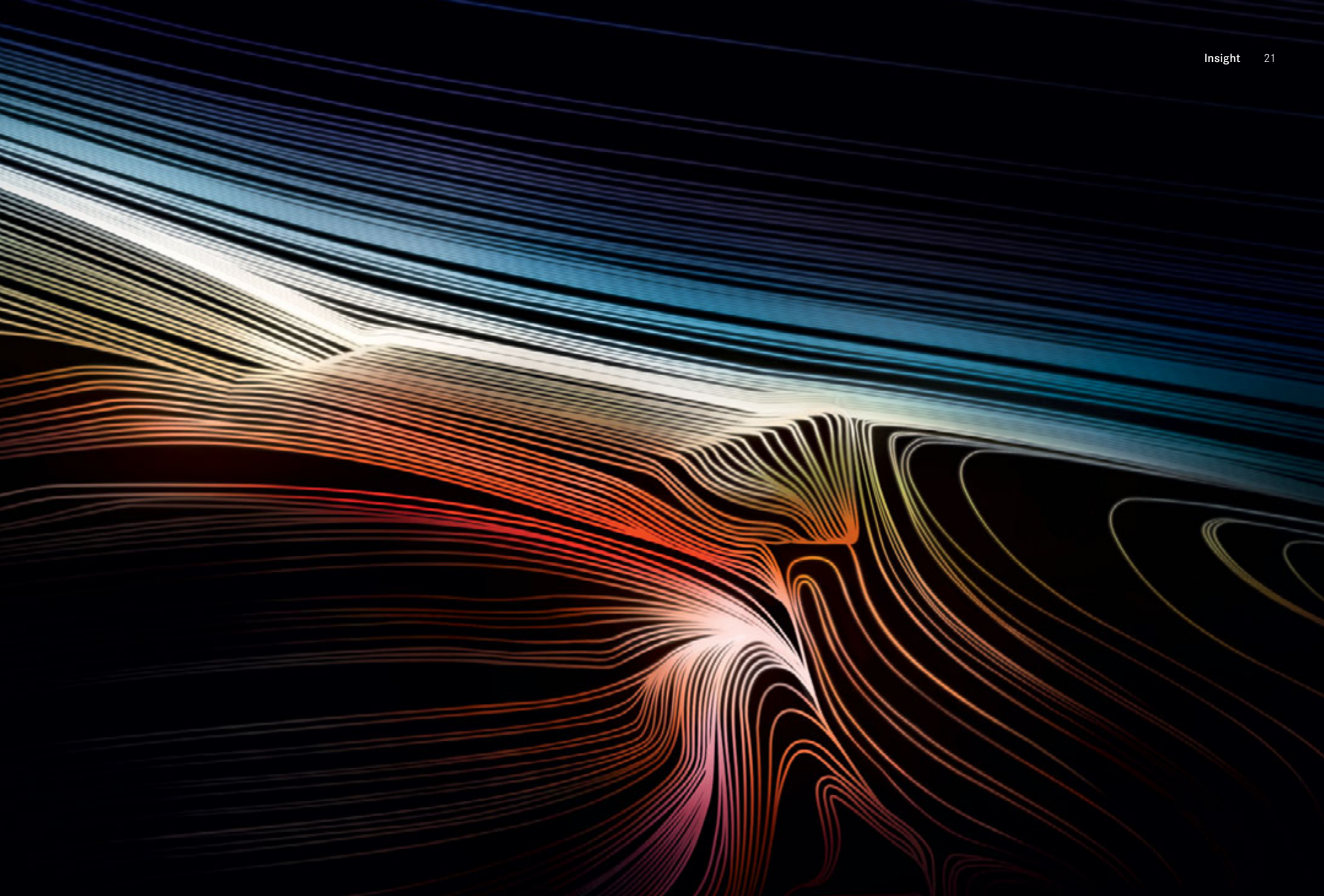

# The new CLA in detail

## Drive system and chassis

- 24 | BlueEFFICIENCY
- 26 | Diesel engines
- 28 | Petrol engines
- 30 | Transmissions
- 31 | Chassis & suspension

## Safety

- 32 | Integral safety concept

## Comfort

- 36 | Multimedia systems
- 38 | Assistance systems
- 40 | Seats
- 41 | Light and climate control

## Equipment & appointments

- 42 | Design and equipment lines and packages
- 60 | Standard equipment
- 61 | Optional extras
- 62 | Wheels
- 64 | Genuine accessories

## Services

- 66 | Star-quality services

## Facts and colours

- 68 | Dimensions
- 68 | Paintwork
- 69 | Technical data

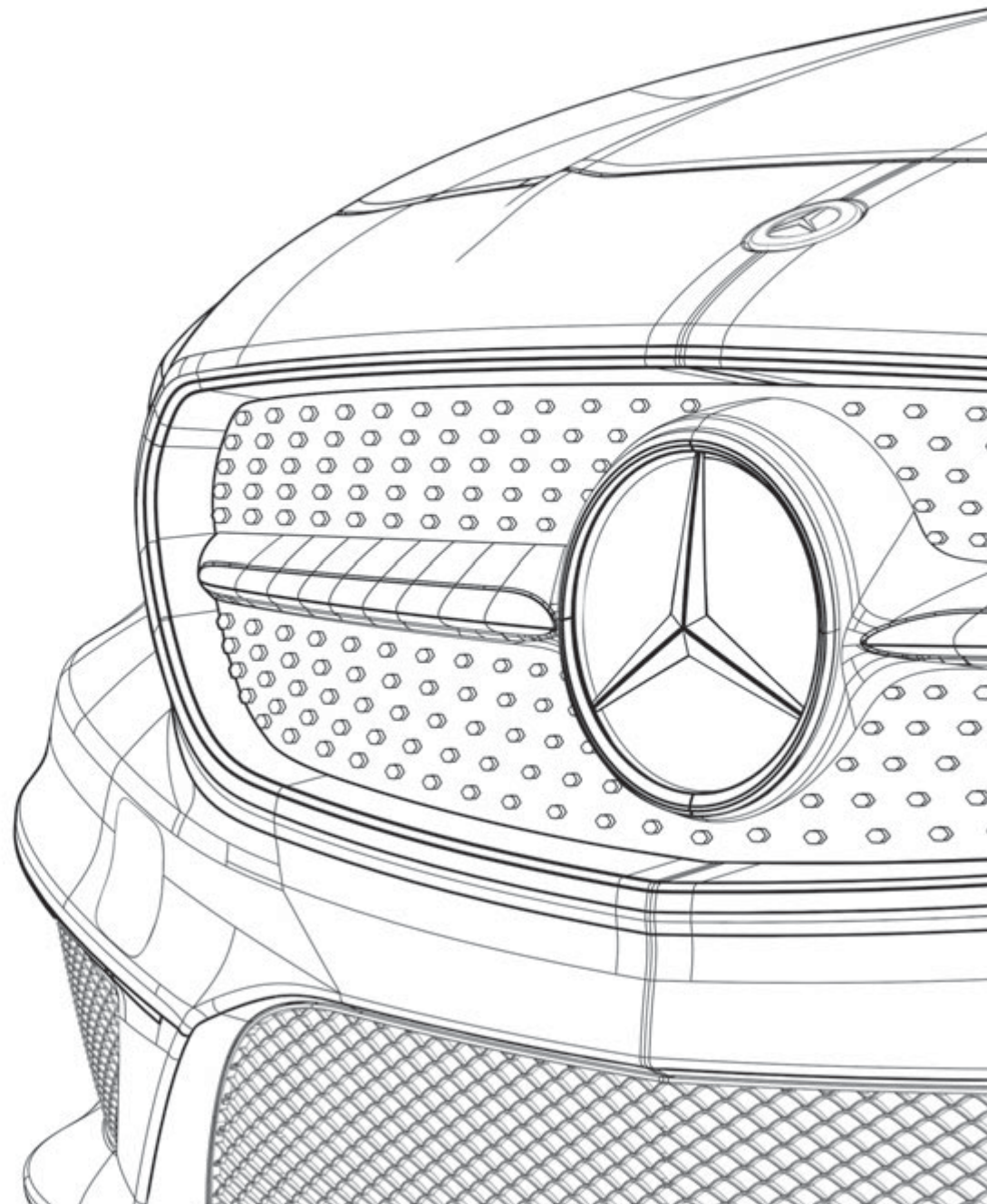

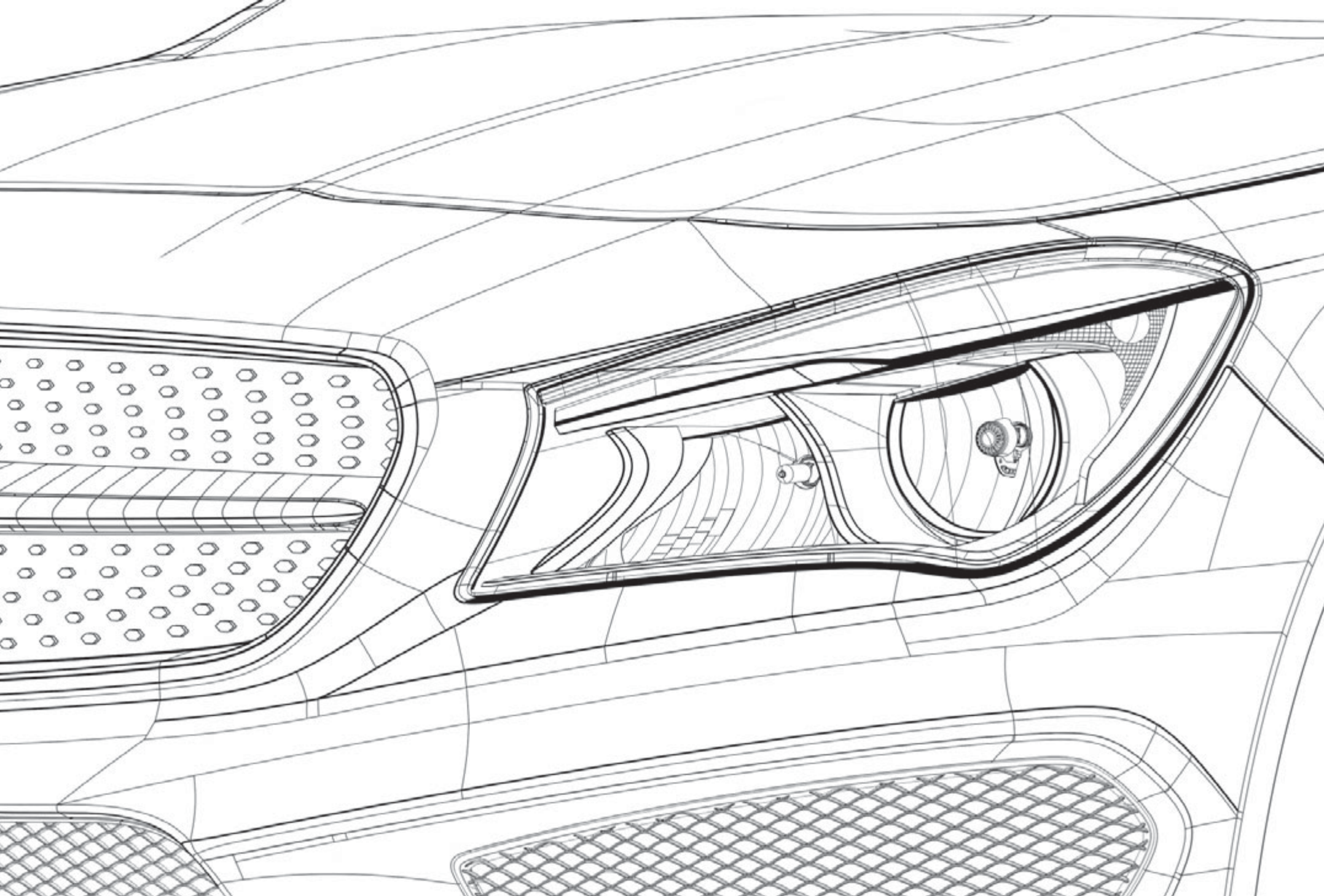

## BlueEFFICIENCY – fast forward to tomorrow

Mercedes-Benz is quicker at getting future technologies to where they matter most: on the road. With the exception of the G-Class all of our 4, 6 and 8-cylinder models now include BlueEFFICIENCY measures that help to reduce your impact on the environment significantly. Our BlueEFFICIENCY concept comprises innovations for efficient mobility as well as optimised processes all the way along the value chain.

**The BlueEFFICIENCY measures – the Mercedes-Benz efficiency package.** A comprehensive set of vehicle enhancements saves fuel and eases the burden on the environment. Each model combines the most efficient engine with the very latest aerodynamic and energy-management measures, including the ECO start/stop function available for most models. The BlueDIRECT V6 and V8 petrol engines featured in many model series deliver more power while reducing consumption by up to 25%. The new BlueEFFICIENCY Edition badge is reserved for the most economical models in selected ranges. These vehicles employ special measures to save weight, reduce air resistance or optimise the drivetrain and thereby achieve even lower fuel consumption and CO<sub>2</sub> figures.

**BlueTEC – the clean diesel.** A modular emission-control system makes BlueTEC an exceptionally clean diesel technology, as it not only removes up to 95% of the particulate matter from the exhaust gases but also reduces nitrogen oxides by up to 90%. What remains is mainly water and nitrogen.

**HYBRID – combustion engine and electric motor intelligently combined.** A well-coordinated team can achieve more, as hybrid technology certainly proves. The electric motor supports the engine during the journey – e.g. with a boost effect for more powerful acceleration – or it acts as a generator, recuperating energy during braking in order to charge the battery (regenerative braking). The latest-generation hybrid drive system is capable of all-electric operation for up to one kilometre at a maximum speed of 35 km/h and also allows efficient, emission-free coasting at speeds below 160 km/h by shutting off the engine on the overrun and disengaging the drive system. And for the first time, these benefits are also available in a premium-class diesel model – without any loss of spaciousness. The E 300 BlueTEC HYBRID<sup>1</sup> is also the world's most economical luxury-segment model.

**Innovative drive systems that break new ground.**

In mid-2013, our electric drive technology will be moving into the fast lane with the arrival of the SLS AMG Coupé Electric Drive<sup>2</sup>, which takes electric driving into a whole new dimension. This super sports car equipped with four synchronous electric motors is our second production-ready electric car and delivers superb performance figures: 552 kW and 1000 Nm make it the most powerful AMG high-performance model ever, yet it produces no local emissions. Another innovative alternative, the hydrogen drive, has also taken to the road at Mercedes-Benz with a small-scale series of B-Class models that use a fuel cell to generate power for the electric motor. Finally, the F 125! represents the future of zero-emission motoring in the luxury class.

But that's not all: under the banner "Design for Environment", we look at a vehicle's entire lifecycle and work hard to preserve the environment, all the way from the planning stage through to recycling. What's more, we are involved in the development of alternative fuels and carry out research in the field of bionics.

Further information about our comprehensive measures can be found at: [www.mercedes-benz.com/blueefficiency](http://www.mercedes-benz.com/blueefficiency)

<sup>1</sup> E-Class E 300 BlueTEC HYBRID Saloon: the vehicle complies with the Euro 5 emissions standard. Fuel consumption – urban: 4.2-4.1 l/100 km, extra-urban: 4.2-4.1 l/100 km, combined: 4.2-4.1 l/100 km; CO<sub>2</sub> emissions combined: 110-107 g/km

<sup>2</sup> SLS AMG Coupé Electric Drive – CO<sub>2</sub> emissions combined in g/km: 0; electrical consumption combined in kWh/100 km: 26.8 The figures shown were obtained in accordance with the prescribed measuring process (Directive [EC] 715/2007 in the currently applicable version). The figures are not based on an individual model and do not constitute part of the product offer; they are provided solely for purposes of comparison between different vehicle models

## BlueEFFICIENCY in the new CLA-Class

The new CLA combines agility and dynamism with efficiency technology aimed at optimising both fuel consumption and emissions



The new CLA is equipped as standard with a raft of measures to reduce fuel consumption and emissions. The BlueEFFICIENCY measures at a glance:

- 1 Ancillaries with energy-saving control (fuel, water and oil pumps), on-demand actuation of air-conditioning compressor and electromechanical Direct-Steer system
- 2 Particularly efficient alternator
- 3 New turbocharged petrol engines with direct injection; diesel engines with optimised combustion. Emission class Euro 6 for petrol engines and CLA 220 CDI
- 4 Excellent aerodynamics with a  $C_d$  value of 0.23 (CLA 180)
- 5 ECO start/stop function as standard
- 6 ECO display to support a fuel-saving driving style as standard
- 7 New 7G-DCT dual clutch transmission (as an option)
- 8 Tyres and wheels with reduced rolling resistance
- 9 Intelligent weight reduction through aluminium (front wings, bonnet and other components)

BlueEFFICIENCY makes the CLA not only more efficient, but more aerodynamic, too. The CLA 180 BlueEFFICIENCY Edition (expected to be available from 2<sup>nd</sup> quarter of 2013) attains the world's lowest  $C_d$  value for a series-production vehicle (0.22). Measures taken to achieve this include the lowering of the body height and the use of a radiator shutter to allow the supply of cooling air to be adjusted in accordance with the driving situation.

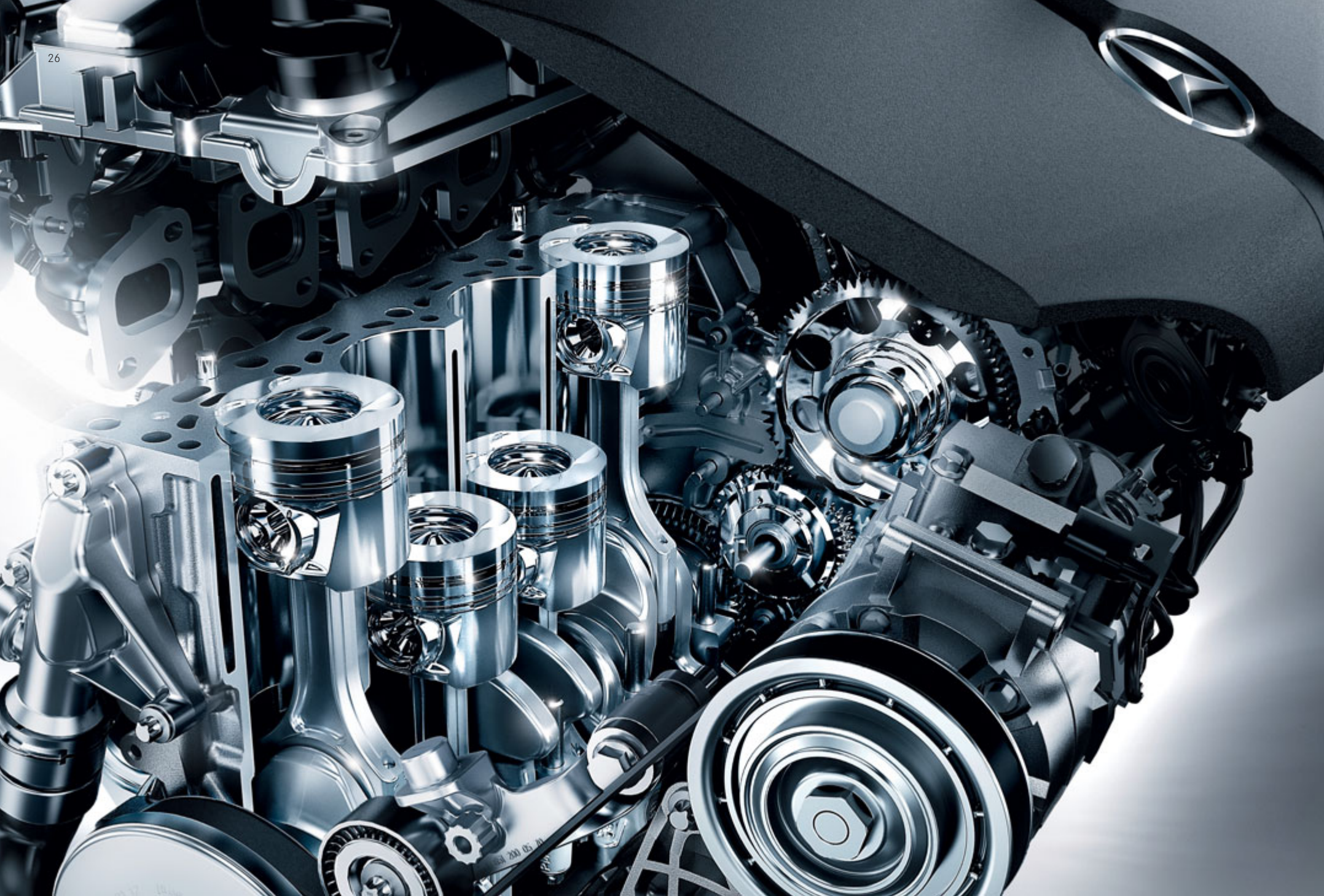

## Diesel engines

Powerful, efficient and clean: the latest Mercedes-Benz diesel technology in the new CLA. Two units impress by delivering high pulling power and performance with low emission and fuel consumption figures

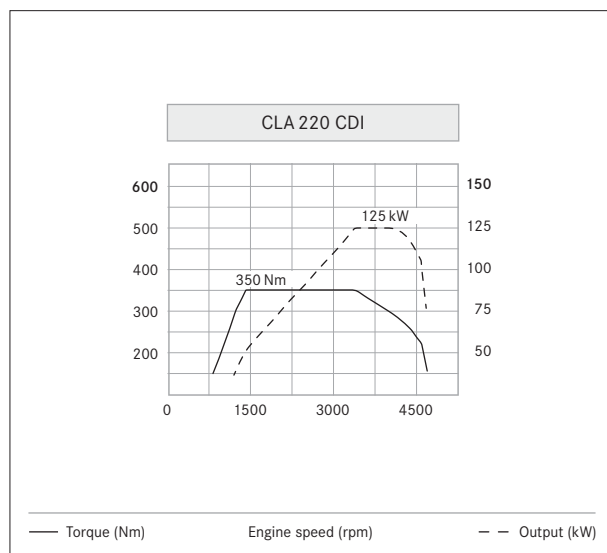

The CLA 220 CDI attains its maximum torque of 350 Nm from just 1400 rpm

**4-cylinder in-line engines.** The up-to-the-minute technology of the 4-cylinder diesel engines is reflected in their hefty torque and excellent responsiveness, even in the lower engine speed range. At the same time, as well as being models of restraint when it comes to fuel consumption and emissions, the engines impress with their low noise level and smooth running characteristics.

Two power outputs are available to choose from in the form of the CLA 200 CDI with 100 kW (136 hp) and a maximum torque of 300 Nm, and as the CLA 220 CDI with 125 kW (170 hp) and a maximum torque of 350 Nm. As the fourth generation of common-rail diesel technology both boast an injection pressure increased to 1800 bar, optimised combustion chambers plus precise solenoid injectors. The high ignition pressure and a turbocharger with variable nozzle

turbine ensure an effortlessly superior torque curve and corresponding pulling power in every engine speed range.

**Further efficiency measures.** Both diesel drive systems are equipped with the ECO start/stop function which switches off the engine temporarily when the vehicle is stationary. In addition to this it goes without saying that they meet the requirements of the Euro 5 emission class. The CLA 220 CDI with multiway exhaust gas recirculation already complies with the requirements of the Euro 6 emission class. Even greater driving efficiency can be achieved with the help of the standard-fit ECO display which indicates how economically the vehicle is being driven at any given moment. This information can be used to adopt a driving style which provides for optimum fuel consumption in the current driving situation.

# Petrol engines

**Setting the standard: the petrol engines in the new CLA combine dynamic power delivery and effortlessly superior ride comfort with low fuel consumption and exemplary emission characteristics**

**4-cylinder in-line engines.** Newly developed for the compact class, the powerplants with a displacement of 1.6/2.0 litres boast direct petrol injection, variable valve timing and a turbocharger. Even at low revs they impress with their excellent responsiveness. Their outstanding performance is heightened further by their exemplary quiet-running characteristics as well as appropriately low fuel consumption and emission figures.

The 4-cylinder petrol engine is available with a choice of three power outputs: as the CLA 180 with 90 kW (122 hp) and a maximum torque of 200 Nm (also as the CLA 180 BlueEFFICIENCY Edition), as the CLA 200 with 115 kW (156 hp) and a maximum torque of 250 Nm and as the CLA 250 with 155 kW (211 hp) and a maximum torque of 350 Nm. All the petrol engines have extremely low emissions and thus already comply with the requirements of the Euro 6 emission class.

The combination of the third-generation Mercedes-Benz high-pressure direct injection system with precise piezo injectors and the enhanced spray-guided combustion process facilitates virtually total combustion and thus allows the fuel to be used particularly efficiently. The variable valve control results in an optimum cylinder charge level which has a beneficial effect on fuel consumption, as do the lower weight, reduced internal friction and ancillaries controlled on an on-demand basis. Turbocharging makes for enhanced responsiveness and higher torque in every engine speed range.

**Further efficiency measures.** The standard ECO start/stop function also enhances the economic efficiency of the engines. Furthermore, the standard-fit ECO display provides feedback about how efficiently the car is being driven. On the basis of this information, the driver can adjust his or her driving style in order to attain the optimum fuel consumption in the current driving situation.

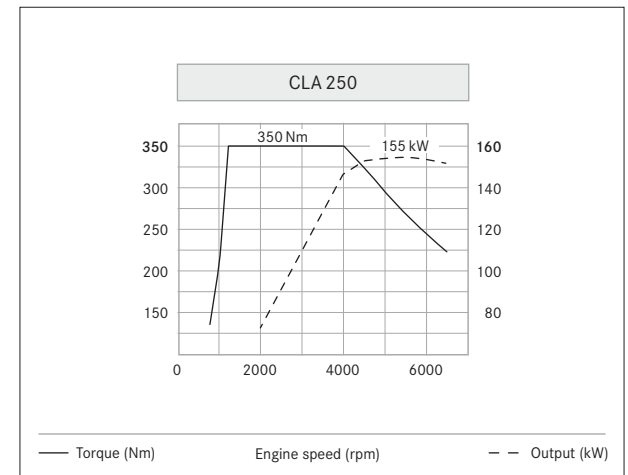

The CLA 250 delivers a peak torque of 350 Nm between 1200 and 4000 rpm



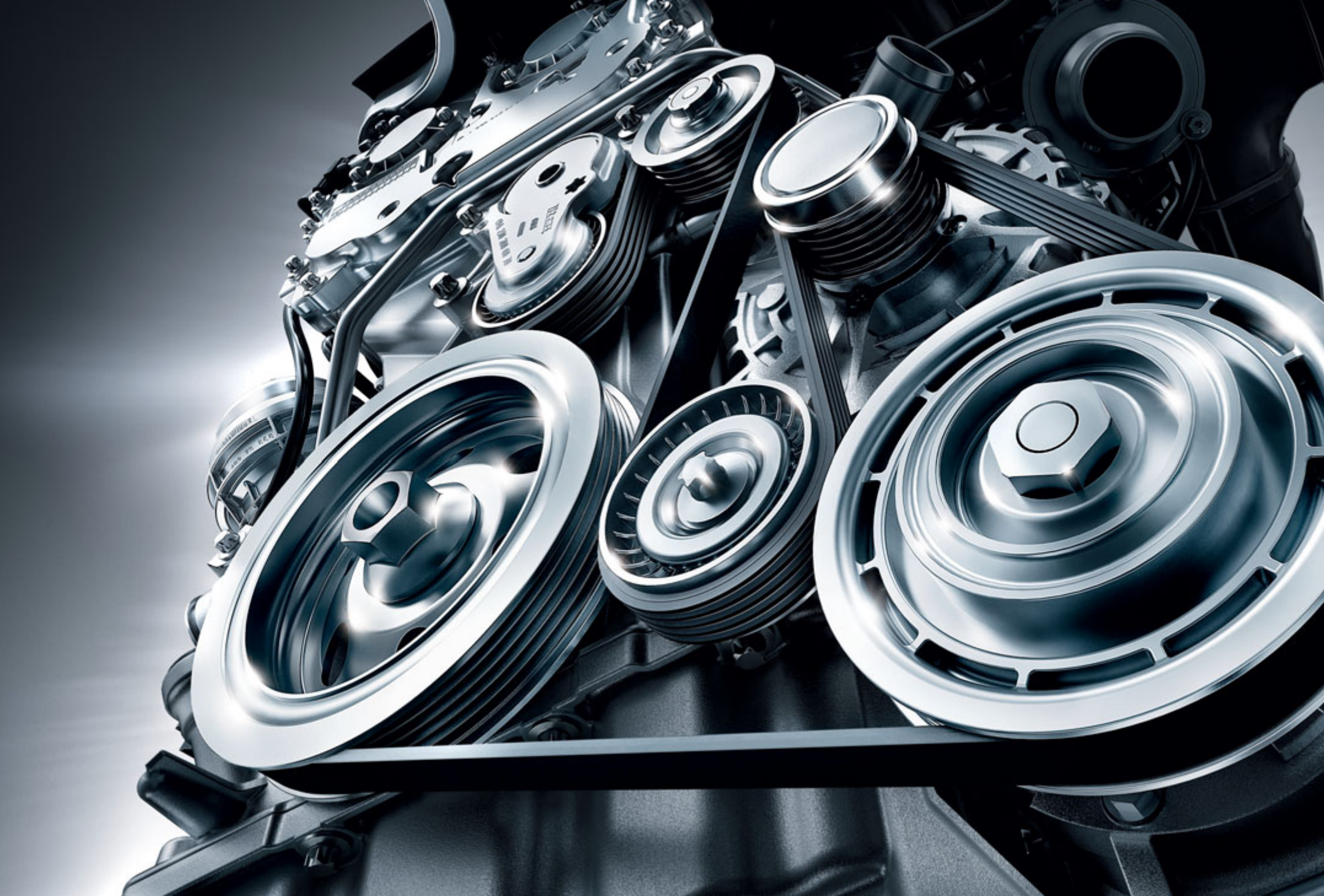

## Transmissions

Power generation is only part of the story. The CLA also excels when it comes to putting it down on the road

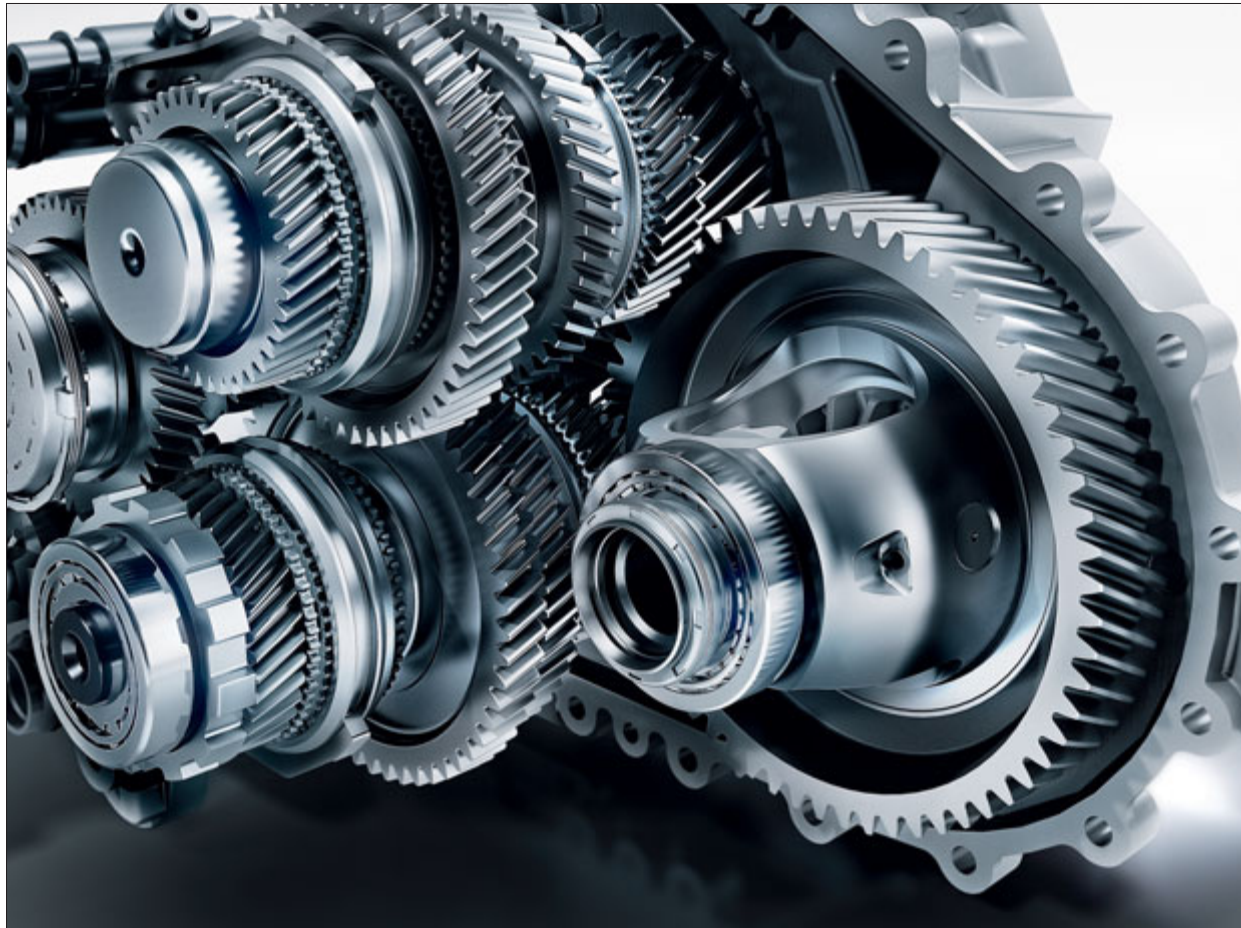

The 7G-DCT seven-speed dual clutch transmission enables gear shifting without any interruption in tractive power

**6-speed manual transmission** (standard for CLA 180, CLA 180 BlueEFFICIENCY Edition and CLA 200). The compact 6-speed manual transmission delivers extremely swift and comfortable gear changes. The shift point indicator provides guidance about the optimum point at which to change gear.

**7G-DCT seven-speed dual clutch transmission** (option, not for CLA 180 BlueEFFICIENCY Edition; standard for CLA 220 CDI and CLA 250). Combining the sporty handling offered by a manual transmission with the comfort of an automatic, this unit consists of two subgearboxes, each of which has a separate clutch. During acceleration or deceleration, the next gear up or down is preselected. When the gear change actually takes place, the drive is switched to the other subgearbox – an arrangement which makes for reduced shift travel and dynamic acceleration. Shifting can even be performed by hand thanks to the steering-wheel gearshift paddles which are included in the package. An ergonomic DIRECT SELECT lever plus the cruise control<sup>1</sup> and SPEEDTRONIC<sup>1</sup> functions are also included in models equipped with 7G-DCT.

<sup>1</sup> Component of Mercedes-Benz Intelligent Drive (see page 32)

## Chassis & suspension

Driving pleasure and dynamic handling to meet your requirements: the new CLA can be set up with the standard comfort suspension or the optional sports suspension

**Comfort suspension** (standard, optional for Urban equipment line). An enhanced McPherson strut front axle and the all-new four-link rear axle ensure a harmonious combination of ride comfort and agility.

**Sports suspension** (component of the optional Urban equipment line and AMG Line, standard for the CLA 180 BlueEFFICIENCY Edition). The springs and dampers have a firm, sporty setup and the vehicle is lowered by 15 mm at the front and 10 mm at the rear.

**Direct-Steer system** (standard). The ratio of the Direct-Steer system varies in accordance with the steering wheel angle while the degree of steering assistance is adjusted on the basis of the road speed. The system reduces the steering effort required when negotiating tight corners or when manoeuvring into a parking space, for example. It also makes for particularly impressive straight-line stability at high speeds. STEER CONTROL, an integral steering assistance system, can support the driver during countersteering and when stabilising the vehicle.

**ESP® Dynamic Cornering Assist** (standard). This system is designed to provide enhanced roadholding during fast cornering. If the standard-fit ESP® sensors register a tendency to understeer whilst the driver is accelerating in a bend, the stability program generates a selective brake actuation at the driven front wheel on the inside of the corner. This causes a slight rotational movement of the vehicle about the vertical axis, the effect being that not only does the vehicle corner more precisely and more controllably; through the reduced risk of understeering it also offers added active handling safety.

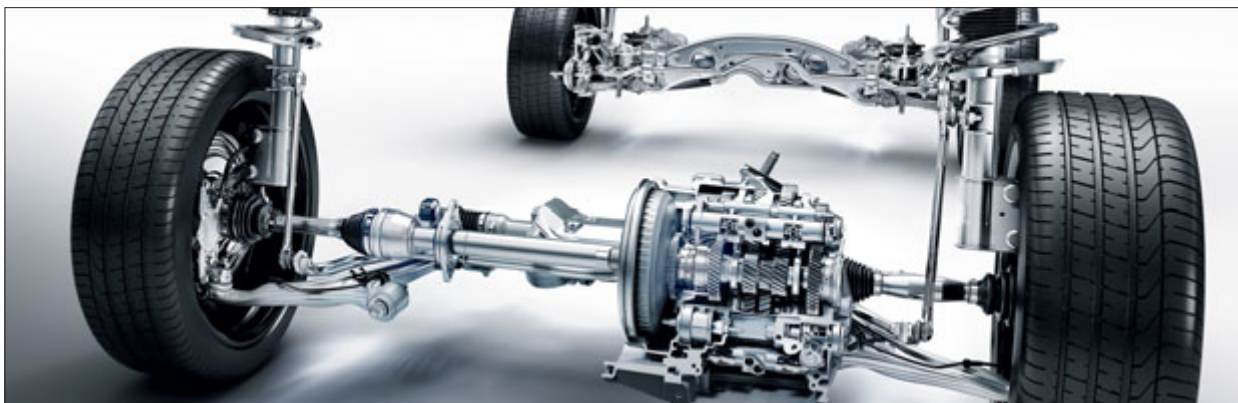

The new CLA is available with a suspension set up to provide a combination of sportiness and comfort or, optionally, for sporty driving

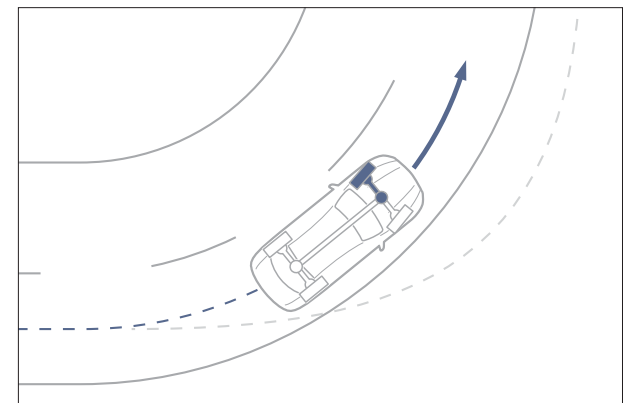

ESP® Dynamic Cornering Assist for more dynamic cornering

## Integral safety concept

We are driven by the vision of accident-free driving. Our integral safety concept takes us a step closer to achieving this. It is a comprehensive approach which paves the way for new, synergy-based technological solutions, a case in point being the “Intelligent Drive” system which combines comfort and safety

As the inventor of the car we feel that we have a special responsibility for road safety. This is why we are the first car manufacturer to have developed an integral safety concept which seamlessly blends measures to enhance active and passive safety. The holistic approach is subdivided into four phases and offers safety solutions for every situation. It includes systems for safe driving which help to avoid risks by warning you and coming to your aid in good time. Our unique PRE-SAFE® system<sup>1</sup> comes into play in the event of danger and activates preventive measures for occupant protection. If a collision should still occur in spite of all the preventive measures, further technologies ensure protection as needed. We have also borne in mind the time immediately following an accident and developed solutions which can help prevent worse and facilitate rapid help. The following pages present a selection of these technologies for the “Safe driving”, “In the event of danger”, “In an accident” and “After an accident” phases.

**Mercedes-Benz Intelligent Drive.** An array of intelligent technological solutions helps to identify critical situations and to reduce the risk of an accident. What’s more, they also result in a sustained reduction in driver stress.

**Safe driving: ATTENTION ASSIST<sup>1</sup>** (standard). Operating in the speed range from 80 to 180 km/h, this system can give the driver visible and audible warnings as soon as it detects signs of increasing inattention or drowsiness. Sensors analyse driving behaviour and can detect deviations from a previously determined, individual driver profile.



If ATTENTION ASSIST detects signs of driver drowsiness or inattention, it recommends taking a break

**Safe driving: COLLISION PREVENTION ASSIST<sup>1</sup>** (standard). Operating in the speed range from 7 to 250 km/h, this static distance warning system can give the driver visible and audible warnings if it detects that the distance to the vehicle/object ahead is too short. During simultaneous braking, Adaptive Brake Assist can place at the driver’s disposal precisely the amount of braking power which is required to prevent an impending collision wherever possible.



COLLISION PREVENTION ASSIST can give the driver visible and audible warnings if the safety margin is too short

**Safe driving: ADAPTIVE BRAKE** (standard). A modular driving dynamics control system which complements the anti-lock braking system (ABS) with additional functions: brake drying can reduce the response time of the brakes – and therefore the stopping distance – in wet conditions. Priming ensures that the brake pads are placed against the brake discs immediately in response to the driver releasing the accelerator pedal quickly. The time gained shortens the response time of the brakes. When moving off on an incline, the vehicle is prevented from rolling back. If the brake pedal is actuated a second time while the vehicle is stationary, the standard-fit HOLD function keeps the vehicle at a standstill, even if the driver releases the brake pedal.

**Safe driving: Lane Tracking package<sup>1</sup>** (option). With the aid of the lane markings, Lane Keeping Assist<sup>1</sup> can detect a traffic lane and, through gentle steering-wheel vibrations, warn the driver if the vehicle is in danger of leaving the lane unintentionally. Blind Spot Assist uses two radar sensors to monitor the area which can only be seen poorly by the driver directly alongside and behind the vehicle. If the system detects the danger of an impending collision with another vehicle when changing lanes, the driver can be warned by visible and audible signals if the car is travelling at 30 km/h

<sup>1</sup> Component of Mercedes-Benz Intelligent Drive

or more (available separately or together in the Lane Tracking Package).

**Safe driving: DISTRONIC PLUS<sup>1</sup>** (option in combination with 7G-DCT). The proximity control helps to maintain a safe distance to the vehicle in front, above all in urban and stop-and-go traffic. If necessary the system can automatically brake and accelerate again afterwards. If there is a risk of a rear-end collision, the COLLISION PREVENTION ASSIST PLUS<sup>1</sup> – part of DISTRONIC PLUS – can initiate partial braking in order to prevent the impact or to reduce the consequences.

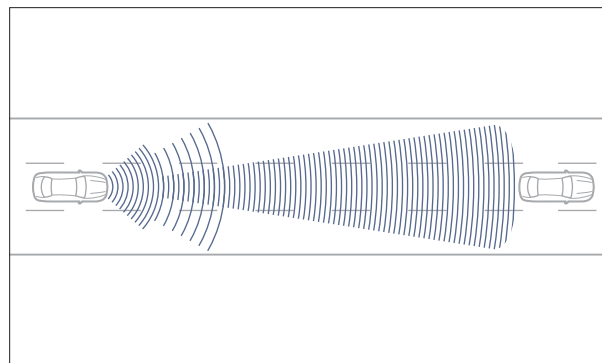

DISTRONIC PLUS supports drivers in keeping their vehicle at a safe distance from the vehicle in front

**Safe driving: Intelligent Light System<sup>1</sup>** (option). The system's lighting functions comprise country mode, motorway mode, enhanced fog lamps, cornering light function, active light function and Adaptive Highbeam Assist<sup>1</sup>. The latter provides the greatest possible low-beam headlamp range, dimming automatically as soon as an oncoming vehicle with its lights on is detected. The LED daytime running lamps and the LED tail lights enhance perceptual safety during the day, too.

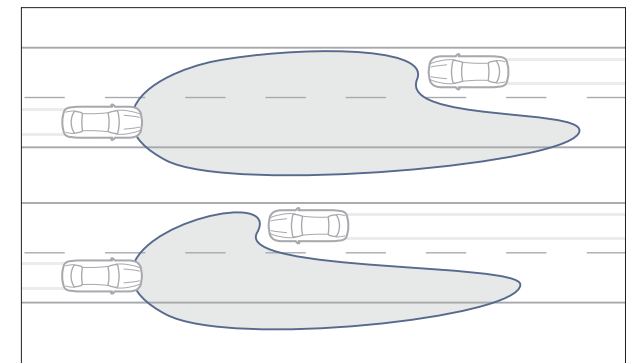

Highbeam Assist dims automatically when it detects oncoming traffic

**In the event of danger: PRE-SAFE® system<sup>1</sup> (option).**

The preventive occupant protection system is able to recognise critical driving situations in advance and, if necessary, can activate safety systems which help to reduce the risk of injury. It does this by continuously monitoring data from ESP<sup>®1</sup> and BAS<sup>1</sup> in order to recognise driving situations such as oversteer/understeer as well as emergency braking. If a critical situation does arise, the belts on the front seats can be tensioned in fractions of a second and all the windows closed automatically. This allows the belts and airbags to deliver their full protective effect should an impact occur. The system also provides for automatic closure of the optional sliding sunroof.

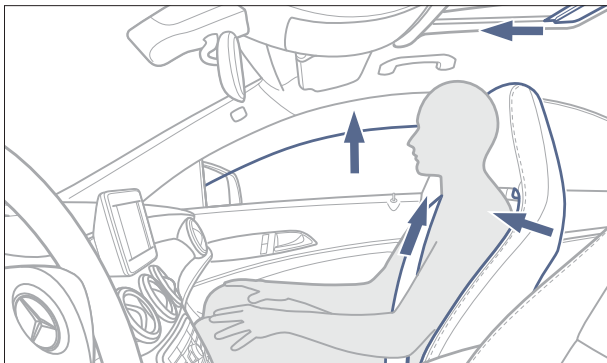

PRE-SAFE® can support the protective effect of seat belts and airbags

**In an accident: active bonnet (standard).** The active bonnet can reduce the risk of injury to pedestrians or cyclists if they are involved in a collision with the bonnet in a speed range between 25 and 55 km/h. To cushion the blow, the bonnet is raised about six centimetres at the rear by means of a pyrotechnic actuator.

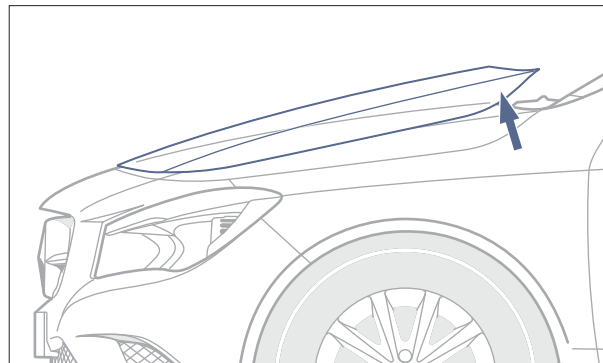

The active bonnet helps to reduce the risk of injury to pedestrians and cyclists in collisions

**In an accident: restraint systems (standard).**

Mercedes-Benz ensures that the three-point seat belts, belt force limiters and airbags are all coordinated optimally to minimise any injuries. The seven airbags fitted as standard help provide comprehensive protection for all the occupants: two-stage front airbags, a continuous windowbag at each side as well as sidebags – in the form of thorax/pelvisbags – for the driver and front passenger. The kneebag can further reduce the forces exerted on the driver during an accident. Rear sidebags are available as an optional extra.

**After an accident: Mercedes-Benz emergency call system**

(component of COMAND Online). This system can make an emergency call automatically using a mobile phone which is on standby and connected to the vehicle as soon as the restraint system detects an accident. At the same time, the GPS position data and other data about the vehicle are transmitted to the Mercedes-Benz emergency call centre, after which a voice connection is established. The emergency call system can also be triggered manually.

<sup>1</sup> Component of Mercedes-Benz Intelligent Drive (see page 32)

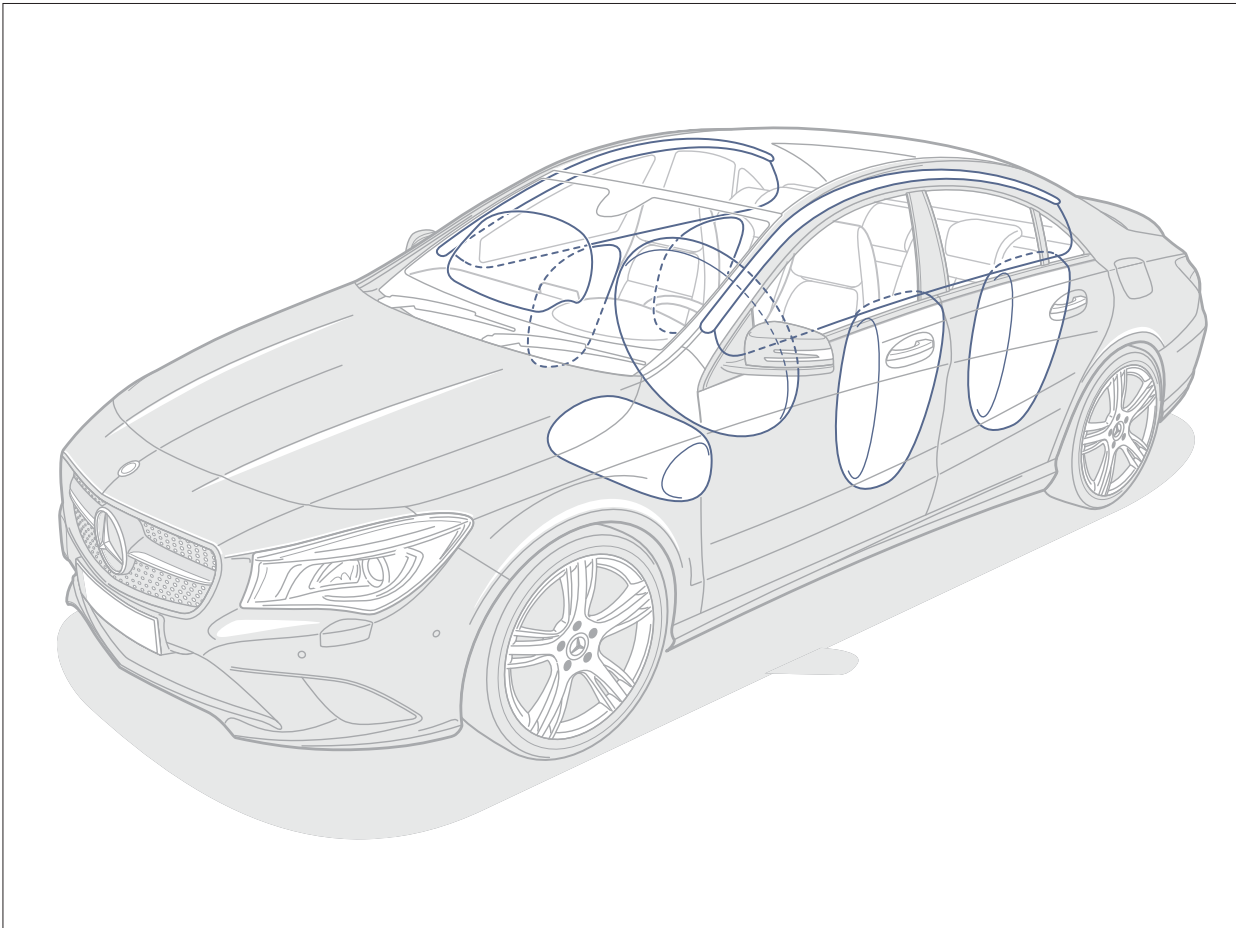

Standard equipment includes windowbags over both rows of seats, airbags and sidebags for the front-seat occupants as well as a driver kneebag

**Measures after an accident.** In order to reduce consequential damage and, where necessary, to support the rescue of the occupants, Mercedes-Benz has developed further measures. These include automatic engine cut-off and activation of the hazard warning lamps and interior emergency illumination. The central locking also unlocks automatically and so makes it easier to open the doors after an impact. In addition, Mercedes-Benz makes Guidelines for Rescue Services available; helpers can download them in different languages all over the world from the internet at [www.mercedes-benz.de/rettungslaufaden](http://www.mercedes-benz.de/rettungslaufaden). As you can see, at Mercedes-Benz consideration is given to safety in every situation.

## Multimedia systems

The new CLA offers a full range of mobile entertainment technology



COMAND Online provides convenient internet access and is equipped with all the key interfaces – for use with an iPhone® or an MP3 player – as well as a high-resolution display with TFT technology

**COMAND Online** (option). Featuring a 17.8 cm display with TFT technology, the multimedia system allows access to the internet at any time when used in conjunction with your mobile phone. A radio, 10 GB of memory and hard-disc navigation are also included. The DVD drive plays video and audio DVDs as well as CDs and MP3 content. Extensive connectivity is provided by USB and Aux-in sockets as well as an SD memory card slot and a Bluetooth® interface. The system is operated via the Controller, the buttons on the multifunction steering wheel or LINGUATRONIC voice control.

**Audio 20 CD** (standard). The system has a 14.7 cm TFT display and can be extended with a CD changer. It can be operated via the multifunction steering wheel or the Controller. A telephone keypad, Bluetooth® interface, Aux-in and USB sockets are included.

**Drive kit plus for the iPhone®** (option). This allows your iPhone® 4/4S to be integrated comprehensively in the new CLA. The accompanying Digital DriveStyle App is available free of charge from the iTunes® Store. The App allows you to use Audio 20 CD and COMAND Online to display content from your iPhone® on the vehicle display and to operate it by means of the Controller.



**Becker® MAP PILOT** (option for Audio 20 CD). The Becker® MAP PILOT combines the advanced functionality of an integral navigation system with the advantages of the latest generation of highly flexible portable devices. All the functions can be used conveniently and safely via the vehicle controls. Maps and additional functions can be updated and extended conveniently by accessing the Becker® MAP PILOT webshop from your home internet connection. Further information is available at [www.beckermappilot.com](http://www.beckermappilot.com)



The functions provided by the Becker® MAP PILOT are indicated on the Audio 20 CD display and the TFT multifunction display in the instrument cluster

**Harman Kardon® Logic 7® surround sound system** (option). Equipped with 12 high-performance loudspeakers and a multi-channel DSP sound amplifier, this Dolby Digital 5.1 system has an output of 450 watts. Combined with COMAND Online or the Audio 20 CD and integral 6-disc CD changer, it delivers an outstanding listening experience.

The Logic 7® multichannel surround sound technology is optimised for the entire occupant compartment and delivers a breathtaking 360-degree audio experience for the occupants of every seat – front and rear.



The Harman Kardon® Logic 7® surround sound system delivers an impressive listening experience for every seat

## Assistance systems

Numerous assistance systems can help ease the burden on the driver and support their perception in the new CLA. For a lower risk of accident and increased safety

**Reversing camera<sup>1</sup>** (option in conjunction with Audio 20 CD or COMAND Online). The reversing camera with a wide-angle lens as well as static and dynamic guide lines switches on when reverse gear is engaged. It provides additional support for the driver during parallel and cross parking manoeuvres by showing the area directly behind the vehicle.



The reversing camera supports the driver when backing into a parking space. It is available in combination with Audio 20 CD and COMAND Online

**Speed Limit Assist** (a component of the optional COMAND Online). This assistance system can detect speed limit signs and display them in the instrument cluster. It does this by means of a windscreen-mounted camera which monitors the area in front of the vehicle continuously and filters out speed limit signs. If the current speed limit changes, the reading on the instrument cluster display is updated accordingly. Speed Limit Assist is especially helpful on routes with variable speed limits or road works.



The information from Speed Limit Assist is shown both in the instrument cluster and in the COMAND Online central display

**Active Parking Assist, including PARKTRONIC<sup>1</sup>** (option). Using Active Parking Assist<sup>1</sup>, the vehicle can automatically identify a suitable parallel or cross parking space when travelling at up to 35 km/h. As soon as the driver confirms acceptance of a proposed parking space and selects reverse, Active Parking Assist parks the vehicle automatically at the touch of a button (and can also manoeuvre out of parallel spaces). The driver only has to operate the transmission, accelerator and brakes while the steering is controlled entirely by Active Parking Assist. The system operates extremely precisely: for automatic parking, a parallel space need only be one metre longer than the vehicle while cross parking spaces need only be 80 cm wider than the vehicle.

<sup>1</sup> Component of Mercedes-Benz Intelligent Drive (see page 32)

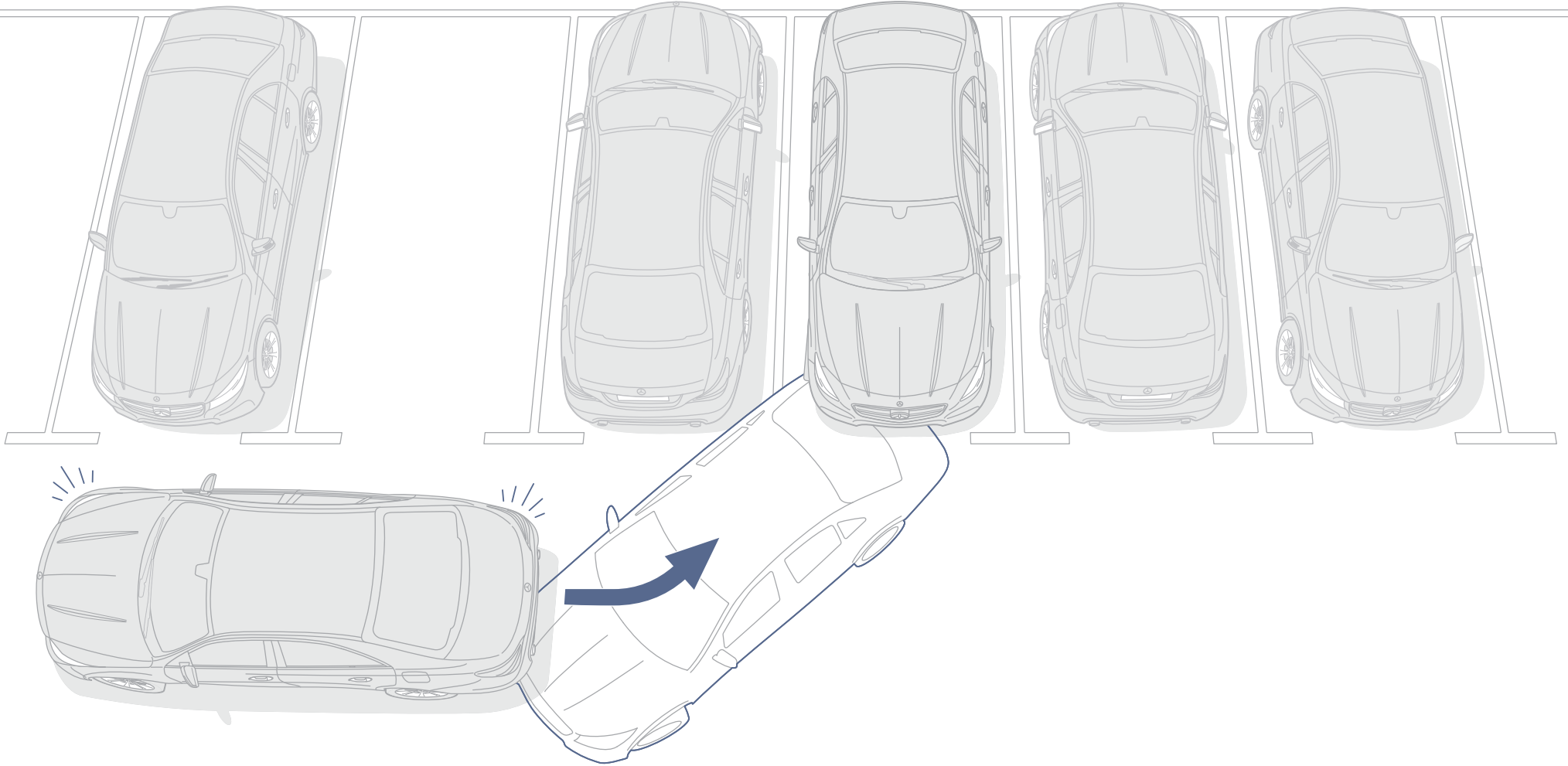

Active Parking Assist can reduce the driver's workload when looking for a parking space and during parallel and cross parking manoeuvres

## Seats

The seats for the new CLA are available in two different variants to meet individual demands regarding ergonomics, seating comfort and safety

**Sports seats** (standard). The standard sports seats are particularly notable for their good lateral support. They can be identified by their high seat backs with triple horizontal fluting and a characteristic opening between the backrest and the new, integral head restraints.

**Luxury seats** (option). The luxury seats with triple horizontal fluting and a wider shoulder area are available in ARTICO man-made leather in black or crystal grey for standard-specification vehicles as well as those with the Urban equipment line.

**4-way lumbar support for driver and front passenger** (option). Both front seats have two inflatable cushions integrated in their backrests. These allow the contour of the backrest to be adjusted in order to provide optimum lumbar support for the driver and front passenger.

**Electric seat adjustment with memory** (option). On request the driver's and front passenger seat are electrically adjustable by means of control switches integrated in the doors for easy access. The memory function can save three individual settings for the position of the seats, the head restraint (not in the case of the sports seats) and the exterior mirrors, and they can be called up again at any time.

**Seat Comfort package** (option for standard-specification vehicles, standard with equipment lines and Exclusive package). This package comprises height adjustment for the front passenger seat plus seat cushion inclination adjustment for both front seats, thereby allowing ergonomic individualisation of the preferred seating position for optimum comfort.



The front and rear seats of the new CLA in leather live up to the name of the Exclusive package, of which they form a part

## Light and climate control

The Light and Sight package typifies the high quality standards of the new CLA and showcases the interior design stylishly when night falls. The THERMOTRONIC automatic climate control can be adjusted to meet the needs of all the passengers

**Light and Sight package** (option). Windscreen wipers with a rain sensor contribute to better visibility in poor weather conditions. Other safety aspects of this package include exit and warning lamps for the front doors as well as a warning and ambient lamp for the boot lid.

Exclusive highlights are created by the indirect ambient lighting in the doors and – where sports seats are fitted – the illuminated opening between the head restraint and backrest, along with other illuminated interior details.

**THERMOTRONIC** (option). The THERMOTRONIC automatic climate control can be adjusted separately for the driver and front passenger. The system also takes account of external factors such as insolation, air quality and humidity.



Illuminated door sill panels



The ambient lighting highlights interior features and represents a particularly distinctive touch in this vehicle class



## Standard equipment

The new CLA combines an expressive character with a sporty, contemporary interior

Avantgarde design and exceptional details: the new CLA impresses with an exterior rich in unconventional details and characterised by great attention to detail. The tone in the new CLA is set by the black radiator grille with a silver-coloured louvre and chrome highlights. The coupé-like roof line and high beltline are given additional emphasis by the standard 10-spoke light-alloy wheels with 205/55 R 16 tyres (CLA 180 and CLA 200). This look is taken even further by the CLA 220 CDI and CLA 250 which have dynamic 10-spoke light-alloy wheels with 225/45 R 17 tyres. It goes without saying that the standard equipment includes the latest generation of such key safety systems as COLLISION PREVENTION ASSIST<sup>1</sup> and ATTENTION ASSIST<sup>1</sup>.



<sup>1</sup> Component of Mercedes-Benz Intelligent Drive (see page 32)





Emotive appeal and practicality are reconciled to perfection in the interior whose standard equipment includes a 3-spoke multifunction steering wheel with 12 function buttons, an instrument cluster in a 2-tube design with a colour TFT multifunction display and sports seats. The sporty handling of the new CLA is complemented perfectly by the Direct-Steer system. Entertainment en route is provided by the Audio 20 CD radio, which includes a USB interface, while the standard-fit air conditioning system maintains a pleasant travelling climate. Also high on the agenda are comfort and convenience features, such as the electric parking brake and details like the front armrest with a stowage compartment. Luxury seats can be ordered as an option.



**Sports seats**

- 351 ARTICO<sup>2</sup>/Coari fabric, black
- 358 ARTICO<sup>2</sup>/Coari fabric, crystal grey
- 151 ARTICO<sup>2,4</sup>, black
- 158 ARTICO<sup>2,4</sup>, crystal grey

**Luxury seat<sup>1</sup>**

- 101 ARTICO<sup>2</sup>, black
- 108 ARTICO<sup>2</sup>, crystal grey

**Trim**

- H88 Matrix-look, black
- H73 AMG carbon fibre<sup>1,3</sup>

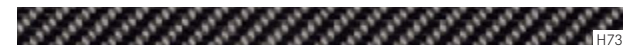
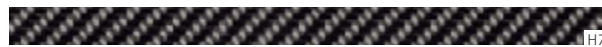

<sup>1</sup> Optional extra   <sup>2</sup> Man-made leather   <sup>3</sup> Expected to be available from 3<sup>rd</sup> quarter of 2013  
<sup>4</sup> Optionally available for an additional charge

## Urban equipment line

The optional Urban equipment line brings out the sporty elegance of the new CLA

From the diamond radiator grille in high-gloss black with a silver-coloured louvre and chrome highlights to the two-pipe exhaust system featuring square tailpipe trims in polished stainless steel, the Urban equipment line offers a stylish tour de force. Notable features include the dynamic 5-twin-spoke light-alloy wheels in himalayas grey with 225/40 R 18 tyres. The sports suspension, which is also standard (comfort suspension optionally available), and the lower-slung body give the car a powerful presence while also making for particularly agile handling with the support of the Direct-Steer system which is standard across the range.







Inside the vehicle, dynamism is also the dominant theme of the Urban equipment line which features a three-spoke multifunction steering wheel with perforated leather in the grip areas and contrasting topstitching. Further features include silver-coloured wave-look trim and sports seats upholstered in ARTICO man-made leather/Corumba fabric with contrasting topstitching in an expanded colour spectrum. Sports seats upholstered entirely in ARTICO man-made leather are available as an option. Luxury seats upholstered in black or crystal grey ARTICO can also be ordered.

---

#### Sports seats

---

- 361 ARTICO<sup>2</sup>/Corumba fabric, black
- 368 ARTICO<sup>2</sup>/Corumba fabric, crystal grey
- 363 ARTICO<sup>2</sup>/Corumba fabric, black/orange<sup>3</sup>
- 151 ARTICO<sup>2, 6</sup>, black
- 158 ARTICO<sup>2, 6</sup>, crystal grey
- 155 ARTICO<sup>2, 6</sup>, sahara beige

---

#### Luxury seat<sup>1</sup>

---

- 101 ARTICO<sup>2</sup>, black
- 108 ARTICO<sup>2</sup>, crystal grey

---

#### Trim

---

- H50 Wave-look, silver
- H51 Wave-look, anthracite<sup>5</sup>
- H73 AMG carbon fibre<sup>1, 4</sup>

<sup>1</sup> Optional extra   <sup>2</sup> Man-made leather   <sup>3</sup> Checked pattern

<sup>4</sup> Expected to be available from 3<sup>rd</sup> quarter of 2013

<sup>5</sup> Available as an option at no extra charge   <sup>6</sup> Option available at extra charge

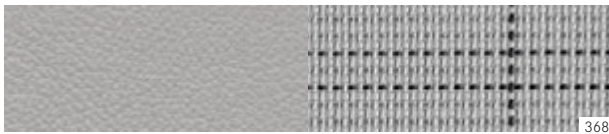



## Night package

The Night package combines striking design ideas, special finishes and superb detailing to give the CLA a particularly harmonious presence in high-gloss black

Striking design ideas and special finishes come together in the optionally available Night package which gives the new CLA an unmistakably sporty and expressive character. The package comprises a high-gloss diamond radiator grille in black (Urban) or silver (AMG Line) with a black louvre, exterior mirrors painted in black, waistline trim

strips and window surrounds in high-gloss black as well as dark-tinted heat-insulating glass for the rear window and rear doors. The Night package is designed as a purely exterior package for further individualisation and is based on the content of the Urban or AMG Line. Where the Urban Line forms the basis, the package comes with 5-twin-spoke

light-alloy wheels painted in black with a high-sheen finish and equipped with 225/40 R 18 tyres. When based on the AMG Line, the new CLA has AMG 5-twin-spoke light-alloy wheels painted in black with a high-sheen finish and equipped with 225/40 R 18 tyres.



## AMG Line

The optional AMG Line is a particularly powerful combination of features designed to deliver an exceptionally dynamic driving experience

The defining features are the AMG bodystyling, comprising front and rear aprons as well as side skirts, the silver-coloured diamond radiator grille with a silver-coloured louvre and chrome highlights as well as the two-pipe exhaust system with square tailpipe trims. Handling and driving enjoyment attain new heights of excellence thanks to the lowered sports suspension while even the appearance of

the headlamps seems to express a hunger for the open road: in conjunction with the optional Intelligent Light System, red highlight rings give the vehicle a particularly alert expression. AMG light-alloy wheels complete the look in accordance with the customer's preferences: they are available in a dynamic 5-twin-spoke design painted titanium grey or black with a high-sheen finish and

225/40 R 18 tyres or, as an alternative, in a dynamic multi-spoke design, either painted in titanium grey with a high-sheen finish or painted in black with a high-sheen rim flange. Whichever wheel design is chosen, the brake callipers make an extremely athletic impression thanks to their Mercedes-Benz lettering and the sporty, perforated brake discs at the front.









Expressive contrasting red topstitching is featured on the black sports seats in ARTICO man-made leather/DINAMICA microfibre, on the flattened multifunction sports steering wheel and on the shift lever in nappa leather, on the armrest in the centre console and in the doors. Further features of the interior include door centre panels in black DINAMICA and a black headlining, light longitudinal-grain aluminium trim, brushed stainless steel sports pedals with rubber studs and cord floor mats with black piping, red topstitching and AMG lettering. A rear door sill panel in aluminium completes the ensemble.

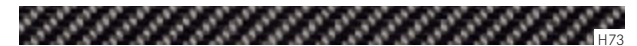
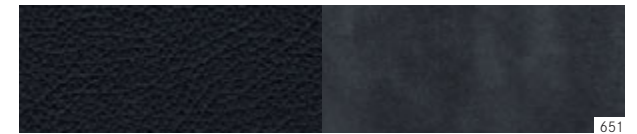

---

#### Sports seats

---

651 ARTICO<sup>2</sup>/DINAMICA<sup>4</sup>, black

---

#### Trim

---

H79 Light longitudinal-grain aluminium

H73 AMG carbon fibre<sup>1, 3</sup>

---

<sup>1</sup> Optional extra <sup>2</sup> Man-made leather

<sup>3</sup> Expected to be available from 3<sup>rd</sup> quarter of 2013 <sup>4</sup> Microfibre





Alcantara

## AMG Exclusive package

The Exclusive package says “sporty” and it says it loud and clear: it is the perfect complement to the AMG Line

Upholstery in black RED CUT leather with red topstitching, light longitudinal-grain aluminium trim, plus in ARTICO man-made leather with contrasting red topstitching on the door centre panels, beltline, armrests and dashboard – it all adds up to an impressively expressive interior.



### Sports seats

811 RED CUT leather, black

### Trim

H79 Light longitudinal-grain aluminium

H73 AMG carbon fibre<sup>1,2</sup>



<sup>1</sup> Optional extra <sup>2</sup> Expected to be available from 3<sup>rd</sup> quarter of 2013

## Exclusive package

The optional Exclusive package meets the requirement for an interior characterised by hand-crafted quality



Long-distance luxury: heated sports seats with 4-way lumbar support for the driver and front passenger in black, crystal grey or nut brown leather upholstery. The steering wheel and selector lever are finished in perforated leather in the grip area. The beltline, door centre panels, armrest and the dashboard are colour-coordinated and, in the case of ARTICO man-made leather upholstery, are enhanced with appropriately contrasting topstitching. Trim elements are in trapezium-grain aluminium (optional alternative trim: high-gloss black ash wood, high-gloss dark brown burr walnut wood or AMG carbon fibre).

---

### Sports seats

- 801 Leather, black
- 808 Leather, crystal grey
- 804 Leather, nut brown

---

### Trim

- 739 Trapezium-grain aluminium
  - 736 High-gloss black ash wood<sup>1</sup>
  - H14 High-gloss dark brown burr walnut wood<sup>1</sup>
  - H73 AMG carbon fibre<sup>1, 2</sup>
- 

<sup>1</sup> Optional extra    <sup>2</sup> Expected to be available from 3<sup>rd</sup> quarter of 2013



801



808

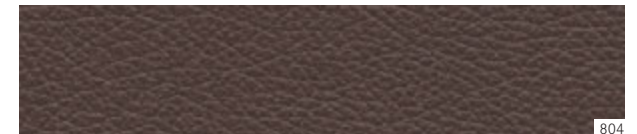

804



739



736



H14

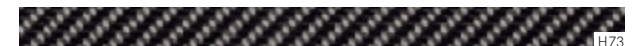

H73



## Standard equipment | Selection



Instrument cluster in 2-tube design with colour TFT multifunction display



12-button three-spoke multifunction steering wheel



Halogen headlamps with integral daytime running lamps



Tail lights including LED tail lamp



Sports seats



Air conditioning



Electric parking brake



Power windows (4)



## Optional extras | Selection



Drive kit plus for the iPhone® 4/4S



Louvre in radiator grille in vehicle colour



Intelligent Light System<sup>1</sup>



Tail lights in LED technology (part of bi-xenon headlamps and Intelligent Light System)



Electrically adjustable front seats, with memory function



THERMOTRONIC automatic climate control



Lane Tracking package with Lane Keeping Assist and Blind Spot Assist (both also available separately)



Panoramic sliding glass sunroof

<sup>1</sup> Component of Mercedes-Benz Intelligent Drive (see page 32)

## Wheels



10-hole steel wheels with wheel trim with 195/65 R 15 tyres (standard for CLA 180 BlueEFFICIENCY Edition, Code R00)



7-spoke light-alloy wheels with 205/55 R 16 tyres, painted matt black with a high-shine finish (option, Code R20)



10-spoke light-alloy wheels with 205/50 R 17 tyres (optional winter wheel, Code 25R)



5-spoke light-alloy wheels with 225/45 R 17 tyres, painted titanium silver (option, Code R24)



Steel wheels with 10-hole wheel trim with 205/55 R 16 tyres (option for CLA 180 and CLA 200, Code 643)



10-spoke light-alloy wheels with 205/55 R 16 tyres, painted champion silver (standard for CLA 200 CDI, CLA 180 and CLA 200, Code 39R)



10-spoke light-alloy wheels with 225/45 R 17 tyres, painted titanium silver (standard for CLA 220 CDI and CLA 250; option for CLA 180 and CLA 200, Code R43)



5-spoke light-alloy wheels with 225/45 R 17 tyres, painted tremolite grey with a high-shine finish (option, Code 02R)



5-twin-spoke light-alloy wheels with 225/40 R 18 tyres, painted black with a high-sheen finish (option, standard for Night package, Code 01R)



5-twin-spoke light-alloy wheels with 225/40 R 18 tyres, painted himalayas grey with a high-sheen finish (option, Code R31)



AMG 5-twin-spoke light-alloy wheels with 225/40 R 18 tyres, painted titanium grey with a high-sheen finish (standard for AMG Line, Code 794)



AMG 5-twin-spoke light-alloy wheels with 225/40 R 18 tyres, painted black with a high-sheen finish (option, Code 781)



5-twin-spoke light-alloy wheels with 225/40 R 18 tyres, painted himalayas grey (option, standard for Urban, Code 66R)



5-triple-spoke light-alloy wheels with 225/40 R 18 tyres, painted himalayas grey and with a high-sheen finish (factory-fitted accessory wheels; Code 64R)<sup>1</sup>



AMG multi-spoke light-alloy wheels with 225/40 R 18 tyres, painted titanium grey with a high-sheen finish (option, Code 791)



AMG multi-spoke light-alloy wheels with 225/40 R 18 tyres, painted black with rim flange in a high-sheen finish (option, Code 646)

<sup>1</sup> Expected to be available from June 2013

## Genuine accessories

Mercedes-Benz genuine accessories offer even greater scope for individual configuration and use of the new CLA. They also solve many a transport problem

**Rear-mounted bicycle carrier.** The convenient, lockable bicycle carrier is available in two versions which allow two or three bicycles to be carried securely. The carrier is simply fitted on to the trailer coupling. Each bicycle rail is designed for a maximum payload of 30 kg. An ingenious folding mechanism means that the boot lid can still be accessed without difficulty. The carrier can be folded quickly and easily for space-saving storage when not in use.



The rear bicycle carrier is available in two versions for two or three bicycles

**Rear spoiler.** The rear spoiler, which is attached to the boot lid, underlines the sporty character of the new CLA by accentuating the airflow breakaway edge. Precision-formed in dimensionally stable polyurethane, it can be fitted easily and securely. The high-quality base coat provides the optimum basis for subsequent painting. A paint finish in the vehicle colour is all that is required to complete the spoiler.



The rear spoiler gives the new CLA an even more powerful presence

**New Alustyle ski and snowboard rack.** The New Alustyle combined ski and snowboard rack is the ideal transport solution for winter sports equipment. Two versions are available: New Alustyle "standard" for up to four pairs of skis or two snowboards and New Alustyle "luxury" for up to six pairs of skis or four snowboards. The rack is fitted to the New Alustyle basic carrier bars. A practical pull-out function makes it easier to load and unload the rack which can also be locked as a security measure.



## Services

**MercedesCard.** As a VISA credit card, this is an internationally accepted means of payment that can offer you a host of additional benefits, such as the Mercedes-Benz insurance package or other exclusive insurance products. There's also the Mercedes-Benz magazine to inspire you with its fascinating features and reports. Further details are available from your Mercedes-Benz dealer.

**Mercedes-Benz Financial Services.** Mercedes-Benz stands for quality, innovation and safety – and the same applies to Mercedes-Benz Financial Services. Our innovative leasing and financing products are tailored to your financial needs and means, making it easy for you to secure the keys to your dream car. Once you are on the road, our insurance products offer you comprehensive protection on every trip. Finally, our service products ensure that your car is always in tip-top condition while keeping costs transparent and easily manageable. For a detailed quotation, please contact your authorised Mercedes-Benz dealer, who will be pleased to go through the latest financial services and terms and conditions with you.

**Mercedes-Benz mobility.** Your new car comes complete with the promise of feeling safe on the road. But if you should ever need assistance, Mercedes-Benz Service24h is there to help. Just call the freephone service hotline on 00800 1 777 7777<sup>1</sup>. The integrated telematics service, Mercedes-Benz Contact<sup>2</sup>, is even more convenient: a touch of a button is all it takes to contact the Mercedes-Benz customer centre. If you wish, relevant vehicle and position-related data are transmitted at the same time, thereby allowing the centre to react quickly and provide rapid on-site assistance. Also standard with your new car at no extra charge is the Mercedes-Benz Mobilo<sup>3</sup> mobility package. Whether you have lost your key, had a breakdown which cannot be repaired immediately or suffered damage to the vehicle due to an accident or vandalism, Mobilo helps you reach your destination – anywhere in Europe. Whatever is holding you up, you will soon be able to resume your journey.

**Mercedes-Benz Museum.** Discover what has been moving the world for over 125 years, and embark on a fascinating journey through automotive history in the Mercedes-Benz Museum. More than 1500 exhibits covering an area of 16,500 square metres chart the unique heritage and innovative flair of the inventor of the motor car. From the very

first model through to the very latest, you will find one legendary car after another awaiting you. The museum is a spectacular sight in its own right too, thanks to an architecture that breaks away from traditional concepts and creates an unprecedented sense of space. Welcome to the Mercedes-Benz Museum – a world of innovation. [www.mercedes-benz-classic.com/museum](http://www.mercedes-benz-classic.com/museum)

**Test drive.** The unique feeling of driving a Mercedes cannot be put into words – you have to experience it for yourself. Take a test drive and find out first hand how it feels to drive your dream car. Please contact your nearest Mercedes-Benz dealer for details.



<sup>1</sup> Alternative: +49 69 95 30 72 77 <sup>2</sup> Requires a factory-fitted radio, connected to an operational mobile phone. The only charge incurred is the cost of the mobile phone call to the landline network <sup>3</sup> Once the mobility guarantee has expired (four years), Mobilo can be extended to provide cover in the event of breakdown and insurance claims one year at a time for a maximum of 30 years, provided that regular maintenance is carried out by your Mercedes-Benz service partner

**Interactive Owner's Manual and Mercedes-Benz Guides.**

The website also offers an interactive tour, enabling you to acquaint yourself with your dream car. You can view key functions in detail, gain an insight into the car's inner workings or look at the benefits of each model. For further details, go to [www.mercedes-benz.de/owners-manual](http://www.mercedes-benz.de/owners-manual). The "Mercedes-Benz Guides" app lets you explore the highlights of the individual models both online and offline. The app is available free of charge from the Apple® iTunes® Store (iOS) as well as the Google Play store (Android).

**Mobile internet.** The entire world of Mercedes-Benz can be accessed at any time with your web-capable mobile device - including specially adapted content for both smartphones and tablets. As well as an overview of all the passenger car models, there are insights into the entire brand world along with a wealth of entertainment offers and direct links to our range of services at [www.mercedes-benz.com](http://www.mercedes-benz.com)

**Mercedes-Benz service contracts.** Vehicle-specific service contracts allow you to arrange individual cover for your Mercedes: for a small monthly premium, the Excellent service contract covers all service jobs including maintenance, wear and repairs for up to five years. Simply present your service card and you will be safe from any unwelcome financial surprises - and you can relax in the knowledge that your Mercedes will stay on top form for a long time to come. The Advance service contract provides a warranty extension, so you will be protected against unexpected repair costs even after the manufacturer's warranty or the Excellent service contract has expired - for up to ten years.



**Accident repairs.** Should the worst happen and you find yourself in need of repairs, with the Mercedes-Benz accident repair service you will receive the best possible assistance for your vehicle and ensure that its high-quality safety features are properly maintained. Whether you need paint, body or glass repair work carried out, the highly trained specialists at your Mercedes-Benz service partner will repair your Mercedes-Benz and get you quickly back on the road again. Further information is available from your authorised Mercedes-Benz dealer.



## Dimensions

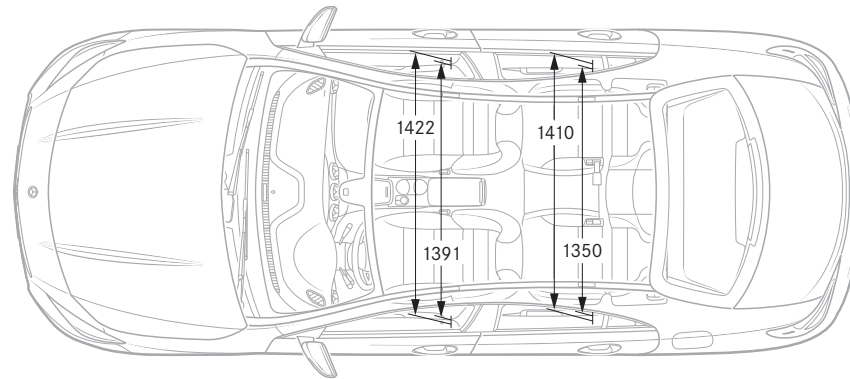
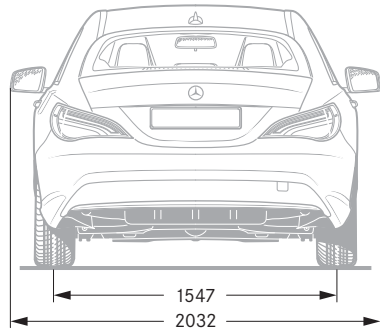
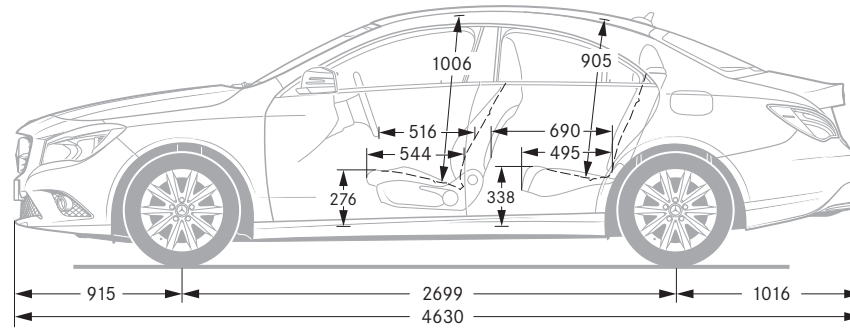
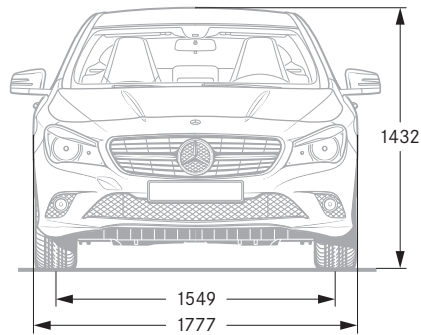

## Paintwork

### Non-metallic paints

589 jupiter red

650 cirrus white

696 night black

### Metallic paints<sup>1</sup>

191 cosmos black

592 northern lights violet

761 polar silver

787 mountain grey

894 universe blue

### Special paints<sup>1</sup>

991 designo polar silver magno<sup>2</sup>

993 designo patagonia red metallic BRIGHT<sup>2</sup>



# Technical data

	Diesel engines		Petrol engines
	CLA 200 CDI	CLA 220 CDI	CLA 180
No. of cylinders/arrangement	4 /in-line	4 /in-line	4 /in-line
Total displacement in cc	1 796	2 143	1 595
Rated output <sup>2</sup> in kW (hp) at rpm	100 (136)/3600-4400	125 (170)/3400-4000	90 (122)/5000
Rated torque <sup>2</sup> in Nm at rpm	300/1600-3000	350/1400-3400	200/1250-4000
Transmissions	6-speed manual [7G-DCT]	7G-DCT	6-speed manual
Acceleration from 0 to 100 km/h in s [automatic transmission]	9.4 [9.3]	- [8.2]	9.3 [-]
Top speed approx. in km/h [automatic transmission]	220 [220]	- [230]	210 [-]
Tyre size, front	205/55 R 16	205/55 R 16 <sup>5</sup>	205/55 R 16
Tyre size, rear	205/55 R 16	205/55 R 16 <sup>5</sup>	205/55 R 16
Fuel	Diesel	Diesel	Premium petrol
Fuel consumption <sup>3</sup> in l/100 km			
Urban [automatic transmission]	5.5-5.3 [5.2-5.0]	- [5.6-5.3]	7.5-7.4 [-]
Extra-urban [automatic transmission]	3.8-3.5 [4.2-3.7]	- [3.8-3.6]	4.5-4.3 [-]
Combined [automatic transmission]	4.4-4.2 [4.5-4.2]	- [4.5-4.2]	5.6-5.4 [-]
CO <sub>2</sub> emissions <sup>3</sup> in g/km combined [automatic transmission]	117-109 [118-109]	- [117-109]	130-126 [-]
Emission class	Euro 5	Euro 6	Euro 6
Tank capacity, incl. reserve, approx. in l	50/6.0	50/6.0	50/6.0
Boot capacity in l	470	470	470
Turning circle diameter in m	11.00	11.00	11.00
Kerb weight <sup>4</sup> in kg [automatic transmission]	1480 [1505]	- [1525]	1395 [-]
Perm. GVW in kg [automatic transmission]	1985 [1985]	- [2005]	1920 [-]

<sup>1</sup> Expected to be available from 2<sup>nd</sup> quarter of 2013 <sup>2</sup> Figures in accordance with Directive 80/1269/EEC in the currently applicable version <sup>3</sup> The figures shown were obtained in accordance with the prescribed measuring process (Directive [EC] 715/2007 in the currently applicable version).  
 The figures are not based on an individual model and do not constitute part of the product offer; they are provided solely for purposes of comparison between different vehicle models

	<b>Petrol engines</b>		
	<b>CLA 180</b>	<b>CLA 200</b>	<b>CLA 250</b>
	<b>BlueEFFICIENCY Edition<sup>1</sup></b>		
No. of cylinders/arrangement	4/in-line	4/in-line	4/in-line
Total displacement in cc	1595	1595	1991
Rated output in kW (hp) at rpm	90 (122)/5000	115 (156)/5300	155 (211)/5500
Rated torque <sup>2</sup> in Nm at rpm	200/1250-4000	250/1250-4000	350/1200-4000
Transmissions	6-speed manual	6-speed manual [7G-DCT]	7G-DCT
Acceleration from 0 to 100 km/h in s [automatic transmission]	9.9 [-]	8.6 [8.5]	- [6.7]
Top speed, approx. in km/h [automatic transmission]	190 [-]	230 [230]	- [240]
Tyre size, front	195/65 R 15	205/55 R 16	225/45 R 17
Tyre size, rear	195/65 R 15	205/55 R 16	225/45 R 17
Fuel	Premium petrol	Premium petrol	Premium petrol
Fuel consumption <sup>3</sup> in l/100 km			
Urban [automatic transmission]	6.8-6.8 [-]	7.5-7.4 [7.1-6.9]	- [8.4-8.4]
Extra-urban [automatic transmission]	4.0-4.0 [-]	4.5-4.4 [4.6-4.2]	- [4.9-4.7]
Combined [automatic transmission]	5.0-5.0 [-]	5.7-5.5 [5.5-5.2]	- [6.2-6.1]
CO <sub>2</sub> emissions <sup>3</sup> in g/km combined [automatic transmission]	118-118 [-]	131-127 [129-122]	- [144-142]
Emission class	Euro 6	Euro 6	Euro 6
Tank capacity, of which reserve, approx. in l	40/6.0	50/6.0	50/6.0
Boot capacity in l	470	470	470
Turning circle diameter in m	11.00	11.00	11.00
Kerb weight <sup>4</sup> in kg [automatic transmission]	1390 [-]	1395 [1430]	- [1480]
Perm. GVW in kg [automatic transmission]	1850 [-]	1920 [1920]	- [1965]

<sup>4</sup> Figures according to Directive 92/21/EC, version 95/48/EC (kerb weight with fuel tank 90% full, driver, 68 kg, and luggage, 7 kg) for standard-specification vehicles. Optional extras and accessories will generally increase this figure and reduce the payload capacity accordingly

<sup>5</sup> Delivered as standard with 10-spoke light-alloy wheels with 225/45 R 17 tyres Further technical data can be found at [www.mercedes-benz.com](http://www.mercedes-benz.com)

Non-metallic paints

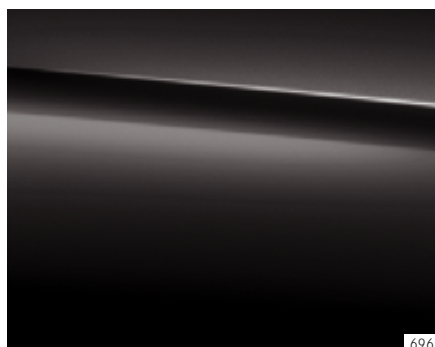
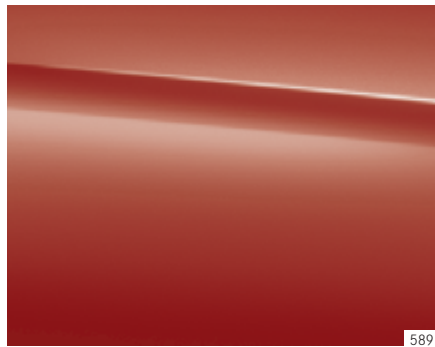

Metallic paints<sup>1</sup>

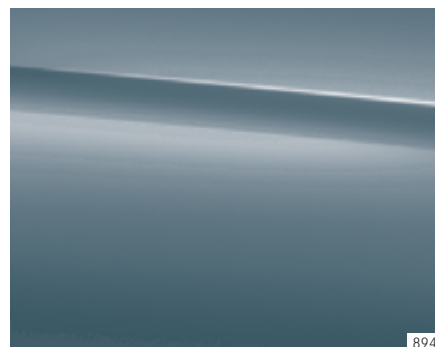
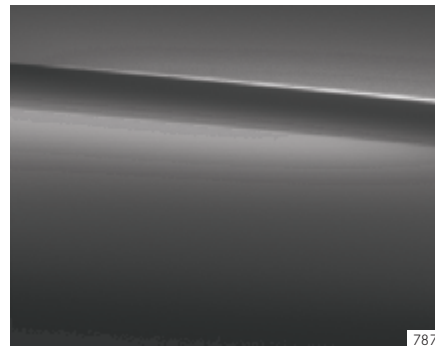
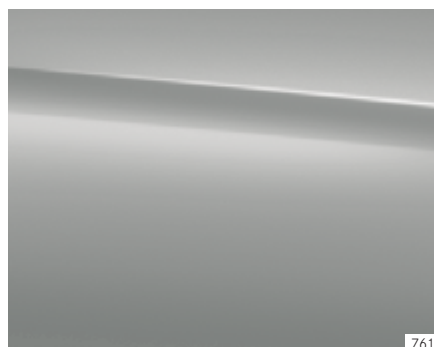
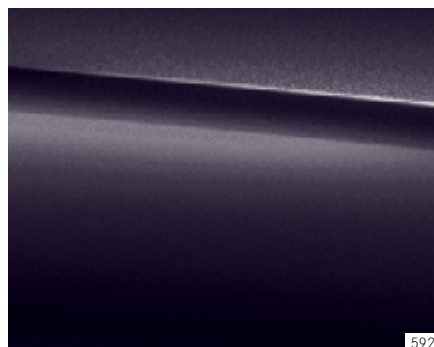
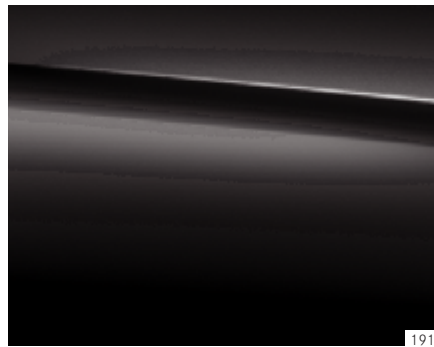

Special paints<sup>1</sup>

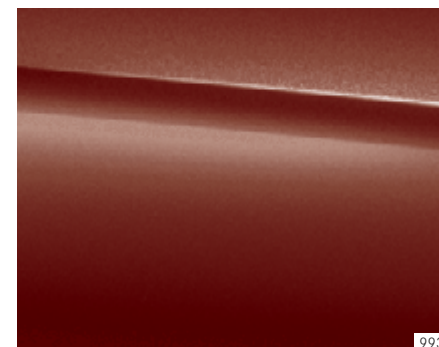
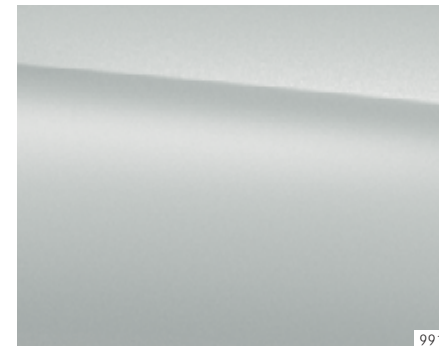

**Take-back of end-of-life vehicles.** You can return your CLA-Class to us for environment-friendly disposal in accordance with the European Union (EU) End-Of-Life Vehicle Directive. But that day lies a long way off.

A network of vehicle take-back depots and dismantlers has been established to make it as easy as possible for you to return your vehicle. You can leave it at any of these points free of charge and, by doing so, make an important contribution to completing the recycling process and conserving resources.

For further information about the recycling and disposal of end-of-life vehicles, and the take-back conditions, please visit the national Mercedes-Benz website.

**Please note:** changes may have been made to the product since this brochure went to press (23.11.2012). The manufacturer reserves the right to make changes to the design, form, colour and specification during the delivery period, provided these changes, while taking into account the interests of the vendor, can be deemed reasonable with respect to the purchaser. Where the vendor or the manufacturer uses symbols or numbers to describe an order or the subject of an order, no rights may be derived solely from these. The illustrations may show accessories and items of optional equipment which are not part of standard specification. Colours may differ slightly from those shown in the brochure, owing to the limitations of the printing process. This brochure is distributed internationally. It provides a general indication of the range of models, features, optional extras and colours available in various countries. Some of the models, features, optional extras and colours shown may not be available in your country or may only be available in a different specification. Additionally some models, features, optional extras and colours may only be available in combination with others. For current and more specific information in relation to the range of models, features, optional extras and colours available in your country, and their pricing, you should contact your nearest authorised Mercedes-Benz Passenger Car Dealer.

**[www.mercedes-benz.com](http://www.mercedes-benz.com)**