

This Brochure is prepared by Daimler AG and it predominantly reflects the capabilities and performance of vehicles sold in Europe. Some characteristics, capabilities, performance features and optional extras (e.g. towing systems) may not be available or may not apply in Australia or under Australian conditions. The information in this Brochure is therefore indicative, illustrative and provided only for guidance and should not be relied on. To obtain current and accurate information on a vehicle and any options applicable to Australia, contact your local authorised Mercedes-Benz dealer.



Mercedes-Benz



The CLS-Class

Coupé and Shooting Brake



Mercedes-Benz

mselves by the status quo will not outdo it. Those who create a car without passion will agile engines and 7G-TRONIC PLUS. Does anyone need luxury? Does anyone need style e-lapped felling in exclusive materials? Yes, they do. After the first drive at the latest. Ecy sports car with a generous amount of space? What do you call a car that has no pee w out ideas and develop new ones. You celebrate successes, but do not rest on them. W o swim against the tide. It takes courage to stray off the beaten track. And a huge amou ke boasts. And that it is only too happy to pass on to you in the form of superior driving houses, motorsport enthusiasts go on pilgrimages to the race track. Should your lugga work. It's always difficult to control the emotions. Especially when looking at the CLS t as many rational reasons for choosing the four-door coupé. After all, seduction begins all the senses. **A new era takes shape.** The successful blend of high-quality wood, fine be unforgiveable. Beauty is not its only trump card. The CLS also features impressive



The fascination of the Shooting Brake. Function follows form, rather than form follows function. The new CLS Shooting Brake turns fundamental design principles upside down. The result is an extraordinary car with unique lines. One of its special features is its expressive tail end which blends seamlessly into the racy overall impression. But the fascinating brother of the CLS Coupé captivates not only with its breathtaking look – but also with its extra variability. The new CLS Shooting Brake. A new era takes shape.

Insight | Page 4 At a glance | from page 6

The fascination of the coupé. Your heart beats faster. Your mind knows why. The CLS reconciles reason and emotion. A passionate form meets impressive technology. Effortlessly superior handling is paired with the latest safety systems. Extraordinary appears to be the norm, which is what makes the car so unashamedly attractive. A blend of outstanding beauty and intelligent design. Of visual appeal and technical excellence. The CLS. The harmonious symbiosis of sensuality and sense.

Insight | Page 22 At a glance | from page 24

The models presented:
CLS 500 BlueEFFICIENCY Shooting Brake designo magno allanite grey cover, from page 6, 10-spoke light-alloy wheels, designo platinum white pearl leather, trim in black piano lacquer
CLS 350 CDI BlueEFFICIENCY Shooting Brake designo magno cashmere white from page 14, 10-spoke light-alloy wheels, Exclusive package, almond beige Exclusive PASSION leather, trim in satin-finish light brown poplar wood
CLS 63 AMG Shooting Brake diamond white BRIGHT from page 18, triple-spoke AMG light-alloy wheels, black leather, trim in carbon fibre
CLS 350 BlueEFFICIENCY designo alubeam titanium cover, from page 24, 5-spoke light-alloy wheels, black/aubergine Exclusive PASSION leather, trim in black piano lacquer
CLS 350 CDI BlueEFFICIENCY thulite red from page 32, 5-spoke AMG light-alloy wheels, AMG Sports package, black/porcelain leather, trim in satin-finish light brown poplar wood
CLS 63 AMG iridium silver metallic from page 36, triple-spoke AMG light-alloy wheels, black leather, trim in black piano lacquer

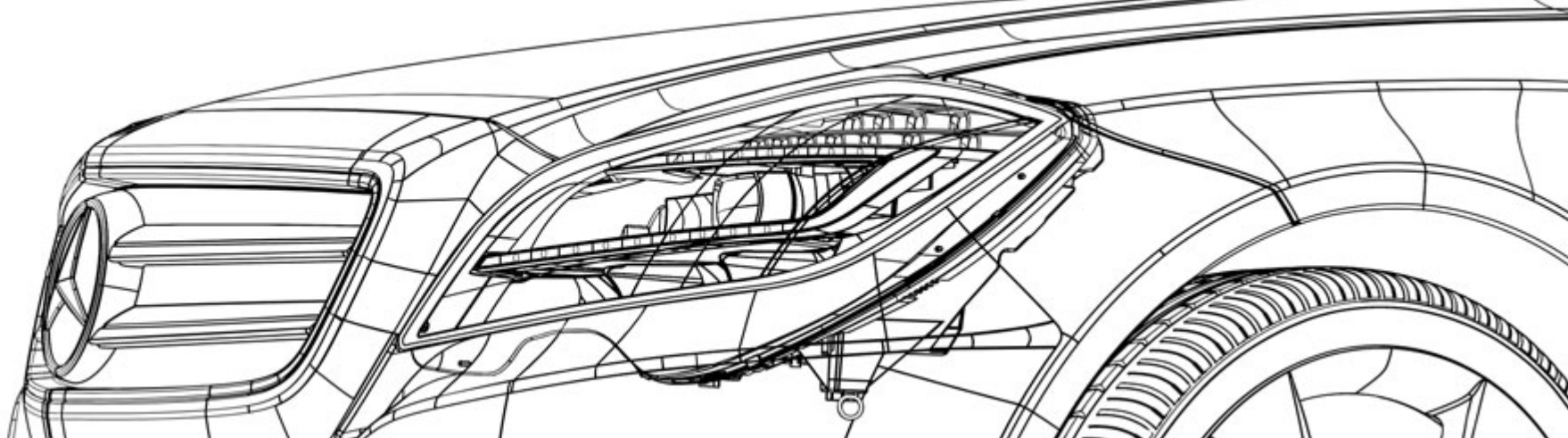

Tangible dynamism: BlueEFFICIENCY, diesel and petrol engines, transmission and chassis.

Drive system & chassis | from page 44

Maximum safety: technology which can help to prevent accidents or can help mitigate their severity and consequences.

Safety | from page 52

Experience the essence of relaxed driving: light, multimedia and assistance systems, seats plus space and variability.

Comfort | from page 56

Exclusivity and performance: CLS 63 AMG exterior, interior, technology and Performance Studio

AMG | from page 66

CLS individuality: standard equipment and optional extras, equipment packages, designo, upholstery and trim, wheels, genuine accessories.

Equipment & appointments | from page 74

Star service: everything about the MercedesCard, Mercedes-Benz Financial Services, Mercedes-Benz mobility, Mercedes-Benz Museum, test drive, Interactive Owner's Manual, mobile internet, service packages and accident repairs.

Services | from page 96

The facts at your fingertips: dimensions, paintwork and technical data.

Facts & colours | from page 98

How the Shooting Brake came by its name





It was a hunting vehicle that gave it its name. We have English noblemen's passion for hunting to thank for the fact that the CLS Shooting Brake was named after it.

Brake was the name once used in England to describe carriages which reined in untamed horses' urge to move. Because the combinations could be easily damaged in the process, versatile coaches were used – they also served to transport a hunting party, along with all the necessary equipment. Such a vehicle, used when going shooting, was known as a shooting brake. In the 1960s motorised

shooting brakes came into fashion, above all in Great Britain. These were cultivated sports cars which afforded their owners the space they required for their sophisticated hobbies – as well as the luxury to which they were accustomed.

With the CLS Shooting Brake Mercedes-Benz is adding a new chapter to the story of this exclusive type of vehicle. And it goes without saying that it is a welcome sight not just in the counties of England. Its hunting grounds also include the boulevards of metropolises all over the world.

You don't herald in a new era
with a fashion fad







Those who orientate themselves by the norm will be overtaken by fashion. Those who orientate themselves by the status quo will not outdo it. Those who create a car without passion will not build one that clings to the road like the new CLS Shooting Brake. Become a hunter yourself. With agile engines and 7G-TRONIC PLUS.

Hunts bends – not trends





Does anyone need luxury? Does anyone need style? Does anyone need a refined taste which is reflected in fine trim? Does anyone need finely stitched double-lapped felling in exclusive materials? Yes, they do. After the first drive at the latest.

Adds a new term to the design idiom

How do you describe something new? How do you put an unseen form into words? How do you christen a racy sports car with a generous amount of space? What do you call a car that has no peer? Allow us to introduce: the new CLS Shooting Brake.







Racing line meets performance curve



You are one step ahead. You rise earlier. You throw out ideas and develop new ones. You celebrate successes, but do not rest on them. Why should you? In order to relax you simply climb into the new CLS Shooting Brake.



Pioneers need horses

It takes courage to swim against the tide. It takes courage to stray off the beaten track. And a huge amount of enthusiasm to be the first to do something new. Properties that the new CLS 63 AMG Shooting Brake boasts. And that it is only too happy to pass on to you in the form of superior driving dynamics. → Page 66-73





V8 biturbo



Everyone needs a special place. Artists paint in their workshops, star tenors sing in opera houses, motorsport enthusiasts go on pilgrimages to the race track. Should your luggage not have a special place too? The optional designo wood floor in open-pore American cherry, with black work.





The future is red, green and blue

The face of a car, its front section, conveys an impression of its character, its temperament and its dynamic credentials: car headlamps communicate this information particularly effectively when their form resembles that of the human eye.

Until recently, however, the limitations of the technology available to the designers hindered their efforts to attain this ideal. But a technological revolution has changed all that: headlamps featuring LEDs (light-emitting diodes). Bright, fast-responding and able to be controlled individually, LEDs in the additive basic colours red, green and blue open up exciting, unrivalled design possibilities which promise forms which have even greater emotional appeal and dynamic potential.

It is not just the aesthetic dimension that is enhanced by the new lighting technology. Visibility for the driver is also improved. This is because the light produced by the LEDs has a colour temperature of 5500 Kelvin – the same as average daylight. And since the human eye has adapted itself to sunlight during the course of evolution, our eyes perceive LED light as particularly pleasant.



Sometimes, words are just not enough



It's always difficult to control the emotions. Especially when looking at the CLS. A design object which has just one aim: to seduce you. Yet for all its expressive looks, there are just as many rational reasons for choosing the four-door coupé. After all, seduction begins in the mind.

Sensuality and sense have never been closer





There's no shame in yielding to temptation as strong as the interior design of the CLS. The successful blend of high-quality wood, fine leather and a trim with an elegant silver-chrome surface appeals to all the senses and will satisfy even the most exacting of design and comfort requirements. In fact, not getting in would be unforgivable.

→ Page 84-91



Looks that take your breath away.
Technology that reduces your CO₂ emissions



Looks that make your heart race.
Safety systems that reassure you

Beauty is not its only trump card. The CLS also features impressive qualities which only reveal themselves at second glance. In critical driving situations, its safety and assistance systems can make all the difference and enhance your safety considerably. It's reassuring to be able to trust the new love in your life straight away. → Page 52-55





Unashamedly flirtatious

Irresistible character: even when at a standstill, the CLS has the power to captivate you. The optionally available AMG Sports package further enhances the feeling of athleticism. And that which is visible is also palpable. → Page 82–83





Three magic words. Shortened to three letters





A detailed view of the interior of a Mercedes-Benz CLS 63 AMG. The image shows the driver's side with the door open, revealing the black leather upholstery, the steering wheel with the Mercedes-Benz logo, the dashboard, and the center console. The interior is illuminated with a soft, ambient light, highlighting the textures of the leather and the metallic accents. The background is a dark, textured wall, possibly made of stone or brick, which adds to the overall aesthetic of the car's interior.

A beautiful body becomes even more attractive when it's honed to perfection. But what's inside matters, too. And that's exactly how it is with the CLS 63 AMG. Settle back into its AMG sports seats upholstered in nappa leather and select your own set-up using the DRIVE UNIT. If only high-performance sport was always this easy and comfortable. → Page 68-69

How to fall in love in seconds. The CLS 63 AMG unleashes your feelings. But it's not just the breathtaking acceleration that transforms every trip into an emotionally charged experience. The athletic AMG design sets even the sportiest of hearts racing. → Page 66-73

Quite possibly the world's fastest declaration of love





upholstery and trim. In an accident. Metallic paints. Sound system. Petrol engines. AMO
pension. Optional extras. Fuel consumption. Interior. In the event of danger. LED daytime
seats. ESP[®]. Dimensions. Standard equipment. Light. Multimedia systems. Drive system
ory package. Transmission. Surround sound system. Wheels. Interior. Safe driving. CO
upholstery and trim. Assistance systems. BlueEFFICIENCY. In an accident. Metallic paint
oy wheels. Top speed. Chassis & suspension. Optional extras. Fuel consumption. Interi
cement. Facts and colours. Climate control. Seats. ESP[®]. Dimensions. Standard equip
ppointments. CO₂ emissions. Memory package. Transmission. Surround sound system.
ylinders. Technical data. Interior. Services. Safety. Assistance systems. Upholstery and
mission class. Safe driving. Light-alloy wheels. Top speed. Optional extras. Chassis & su
unning lamps. **The facts.** Paintwork. Total displacement. Climate control. Seats. Dimer
s. Light-alloy wheels. Memory package. Transmission. Surround sound system. Wheels

44 **BlueEFFICIENCY**45 **CLS BlueEFFICIENCY**46 **Diesel engines**

4-cylinder

6-cylinder

48 **Petrol engines**

6-cylinder

8-cylinder

50 **Transmission**

7G-TRONIC PLUS

51 **Chassis & suspension**

The all-wheel drive system 4MATIC

AIRMATIC air suspension

DIRECT CONTROL suspension

52 **Integral safety concept**

ATTENTION ASSIST

Night View Assist Plus

Lane Tracking package

Driving Assistance package Plus

LED tail lights and adaptive brake lights

PRE-SAFE® system

PRE-SAFE® Brake

Brake Assist BAS PLUS

Restraint systems

NECK-PRO head restraints

Mercedes-Benz emergency call system

Measures after an accident

56 **Light**

LED High Performance headlamps

LED Intelligent Light System

Bi-xenon headlamps

LED tail lights with night design

58 **Multimedia systems**

COMAND Online

Audio 20 CD

Becker® MAP PILOT

Harman Kardon® Logic 7®

surround sound system

Bang & Olufsen

high-end sound system

60 **Assistance systems**

Speed Limit Assist

Reversing camera

Active Parking Assist with PARKTRONIC

62 **Seats**

Memory package

Active Multicontour Seat package

NECK-PRO luxury head restraints

Individual rear seats

64 **Space**

Load compartment

Designer aluminium rails

EASY-PACK load-securing kit

Flexibility

66 **CLS 63 AMG exterior**68 **CLS 63 AMG interior**70 **CLS 63 AMG technology**

AMG 5.5-litre V8 engine

AMG SPEEDSHIFT MCT

7-speed sports transmission

AMG RIDE CONTROL

sports suspension

72 **AMG Performance Studio**

74 Standard equipment**76 Optional extras****78 Equipment packages**

Exclusive package

Exterior Sports package

AMG Sports package

84 designo**86 Upholstery and trim****92 Wheels**

Standard wheels

Optional wheels

AMG wheels

94 Genuine accessories

Rear Seat Entertainment System

incenio light-alloy wheels

Door sill panels

96 Services

MercedesCard

Mercedes-Benz Financial Services

Mercedes-Benz mobility

Mercedes-Benz Museum

Test drive

Interactive Owner's Manual

Mobile internet

Service packages

Accident repairs

98 Dimensions**98 | 101 Paintwork****99 Technical data**

BlueEFFICIENCY – fast forward to tomorrow

Mercedes-Benz is quicker at getting future technologies to where they matter most: on the road. With the exception of the G-Class and R-Class, all of our 4, 6 and 8-cylinder models now include BlueEFFICIENCY measures that help to reduce your impact on the environment significantly. Our BlueEFFICIENCY concept comprises innovations for efficient mobility as well as optimised processes all the way along the value chain.

The BlueEFFICIENCY measures – the Mercedes-Benz efficiency package. A comprehensive set of vehicle enhancements saves fuel and eases the burden on the environment. Each model combines the most efficient engine with the very latest aerodynamic and energy-management measures, including the ECO start/stop function available for most models. The BlueDIRECT V6 and V8 petrol engines featured in many model series deliver more power while reducing consumption by up to 25%. The new BlueEFFICIENCY Edition badge is reserved for the most economical models in selected ranges. These vehicles employ special measures to save weight, reduce air resistance or optimise the drivetrain and thereby achieve even lower fuel consumption and CO₂ figures.

BlueTEC – the clean diesel. A modular emission-control system makes BlueTEC an exceptionally clean diesel technology, as it not only removes up to 95% of the particulate matter from the exhaust gases but also reduces nitrogen oxides by up to 90%. What remains is mainly water and nitrogen.

HYBRID – combustion engine and electric motor intelligently combined. A well-coordinated team can achieve more, as hybrid technology certainly proves. The electric motor supports the engine during the journey – e.g. with a boost effect for more powerful acceleration – or it acts as a generator, recuperating energy during braking in order to charge the battery (regenerative braking). The latest-generation hybrid drive system is capable of all-electric operation for up to one kilometre at a maximum speed of 35 km/h and also allows efficient, emission-free coasting at speeds below 160 km/h by shutting off the engine on the overrun and disengaging the drive system. And for the first time, these benefits are also available in a premium-class diesel model – without any loss of spaciousness. The E 300 BlueTEC HYBRID¹ is also the world's most economical luxury-segment model.

Innovative drive systems that break new ground.

In mid-2013, our electric drive technology will be moving into the fast lane with the arrival of the SLS AMG Coupé Electric Drive², which takes electric driving into a whole new dimension. This super sports car equipped with four synchronous electric motors is our second production-ready electric car and delivers superb performance figures: 551 kW and 1000 Nm make it the most powerful AMG high-performance model ever, yet it produces no local emissions. Another innovative alternative, the hydrogen drive, has also taken to the road at Mercedes-Benz with a small-scale series of B-Class models that use a fuel cell to generate power for the electric motor. Finally, the F 125! represents the future of zero-emission motoring in the luxury class.

But that's not all: under the banner "Design for Environment", we look at a vehicle's entire lifecycle and work hard to preserve the environment, all the way from the planning stage through to recycling. What's more, we are involved in the development of alternative fuels and carry out research in the field of bionics.

Further information about our comprehensive measures can be found at: www.mercedes-benz.com/blueefficiency

¹ E-Class E 300 BlueTEC HYBRID Saloon: the vehicle complies with the Euro 5 emissions standard. Fuel consumption – urban: 4.2–4.3 l/100 km, extra-urban: 4.2–4.3 l/100 km, combined: 4.2–4.3 l/100 km; CO₂ emissions combined: 109–112 g/km

² SLS AMG Coupé Electric Drive – CO₂ emissions combined in g/km: 0; electrical consumption combined in kWh/100 km: 26.8 The figures shown were obtained in accordance with the prescribed measuring process (Directive [EC] 715/2007 in the currently applicable version). The figures are not based on an individual model and do not constitute part of the product offer; they are provided solely for purposes of comparison between different vehicle models

CLS BlueEFFICIENCY

The CLS adopts a holistic approach, combining agility and dynamism with leading-edge efficiency technologies as well as extensive packages of measures aimed at optimising both fuel consumption and emissions.



When we develop a new model, responsibility for our environment plays a major role. People's awareness is increasing as emissions, fuel consumption and fuel prices become topics that affect us all. It is therefore only natural that the CLS models should also be BlueEFFICIENCY models (with the exception of the CLS 63 AMG). And, far from being just a vision of a clean environment, BlueEFFICIENCY incorporates a whole raft of specific measures:

- 1 Ancillaries with energy-saving control (oil, water and fuel pumps, electromechanical steering)
- 2 Radiator shutter for CLS 250 CDI BlueEFFICIENCY and CLS 350 BlueEFFICIENCY
- 3 Alternator management with energy recuperation
- 4 BlueDIRECT V6 and V8 engine generation with direct petrol injection, plus twin turbochargers for the CLS 500 BlueEFFICIENCY and CLS 500 4MATIC BlueEFFICIENCY
- 5 Refrigerant compressor only activated when actually needed
- 6 Optimised aerodynamics (exterior-mirror housings, front apron, rear apron, underbody)
- 7 ECO start/stop function (not for CLS 350 CDI BlueEFFICIENCY Coupé or CLS 350 CDI 4MATIC BlueEFFICIENCY)
- 8 Optimisation of rolling resistance (depending on the wheel/tyre combination)
- 9 Optimised 7G-TRONIC PLUS automatic transmission

Diesel engines

Powerful and quiet with remarkably low fuel consumption and emissions: the CLS features the latest diesel technology from Mercedes-Benz.

4-cylinder in-line engine. The qualities of the 4-cylinder diesel powerplant are very much in tune with the times: it delivers an impressive maximum torque of 500 Nm. At the same time, the diesel engine is sparing on fuel, offers low CO₂ emissions of 158–170 g/km (combined), is quiet and – at 150 kW (204 hp) – particularly powerful for its displacement class. This is made possible through a package of cutting-edge technologies. The current generation of common-rail diesel technology impresses with its injection

pressures of up to 2000 bar, optimised combustion chambers and particularly fast and precise piezo injectors. High ignition pressure and two-stage charging are responsible for the availability of high torque across the engine speed range. Two Lanchester balancer shafts ensure the required smooth running. The ECO start/stop function stops the engine temporarily when the car comes to a halt, while optimised alternator management ensures consistent use of the engine's coasting phases as well as the braking

process in order to recuperate kinetic energy. Meanwhile the radiator shutter reduces the aerodynamic drag when the engine requires only moderate cooling. But that is not all: this model also features integral measures such as tyres with reduced rolling resistance (depending on the wheel/tyre combination), intelligently controlled ancillaries and improved aerodynamics, all of which help to boost the car's efficiency sustainably.

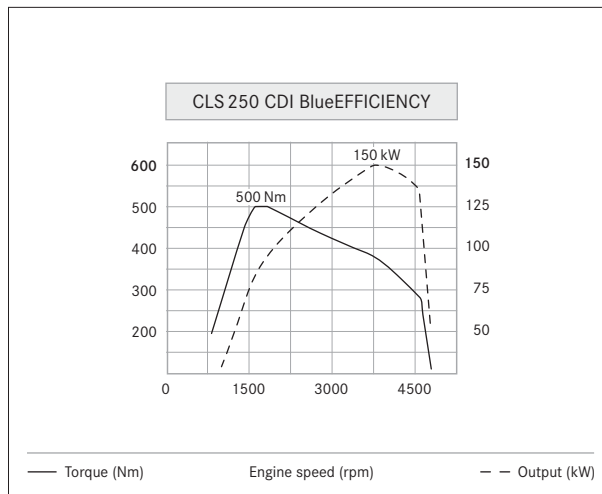

The CLS 250 CDI BlueEFFICIENCY achieves its peak torque of 500 Nm at between just 1600 and 1800 rpm



The CLS 250 CDI BlueEFFICIENCY combines pulling power with low fuel consumption and emissions



The CLS 350 CDI BlueEFFICIENCY with an output of 195 kW (265 hp)

V6 engine. The CLS 350 CDI BlueEFFICIENCY and the CLS 350 CDI 4MATIC BlueEFFICIENCY also place the emphasis on efficiency. Amongst the features which have been developed for the V6 diesel engine is an intake and exhaust system with optimised inflow and outflow characteristics, boosting the output to 195 kW (265 hp), making this the most powerful diesel drive system with common-rail technology available for the CLS. Furthermore, fast and precisely controlled piezo injectors, a high injection pressure of up to 1600 bar and an optimised turbocharger help to save fuel. With the engine developing an immense peak torque of 620 Nm at 1600–2400 rpm, the result is effortlessly superior pulling power in all driving situations. What's more, the low engine noise level meets even the most exacting of requirements. And the integral ECO start/stop function (not in the CLS Coupé) can reduce the fuel consumption and the emissions by up to 4%.

Petrol engines

The BlueDIRECT petrol engines were developed with the aim of substantially reducing fuel consumption and emissions without compromising on dynamism and ride comfort. The result: advanced engine technology from Mercedes-Benz.

V6 engine. Humble fuel consumption and correspondingly low CO₂ emissions yet high dynamism – the CLS 350 BlueEFFICIENCY is as impressively efficient as its name suggests. These advantages are primarily down to the current-generation direct petrol injection from Mercedes-Benz, which operates using spray-guided combustion and high-pressure injection by means of piezo injectors. Maximum output is 225 kW (306 hp), while the peak torque of 370 Nm is available between 3500 and 5250 rpm. Further factors which help to reduce fuel consumption include the standard-fit ECO start/stop function, an efficient intake and exhaust system, controlled ancillaries, intelligent alternator management, and consistently applied lightweight-design principles. What's more, this is one of the smoothest-running V6 engines in its class.

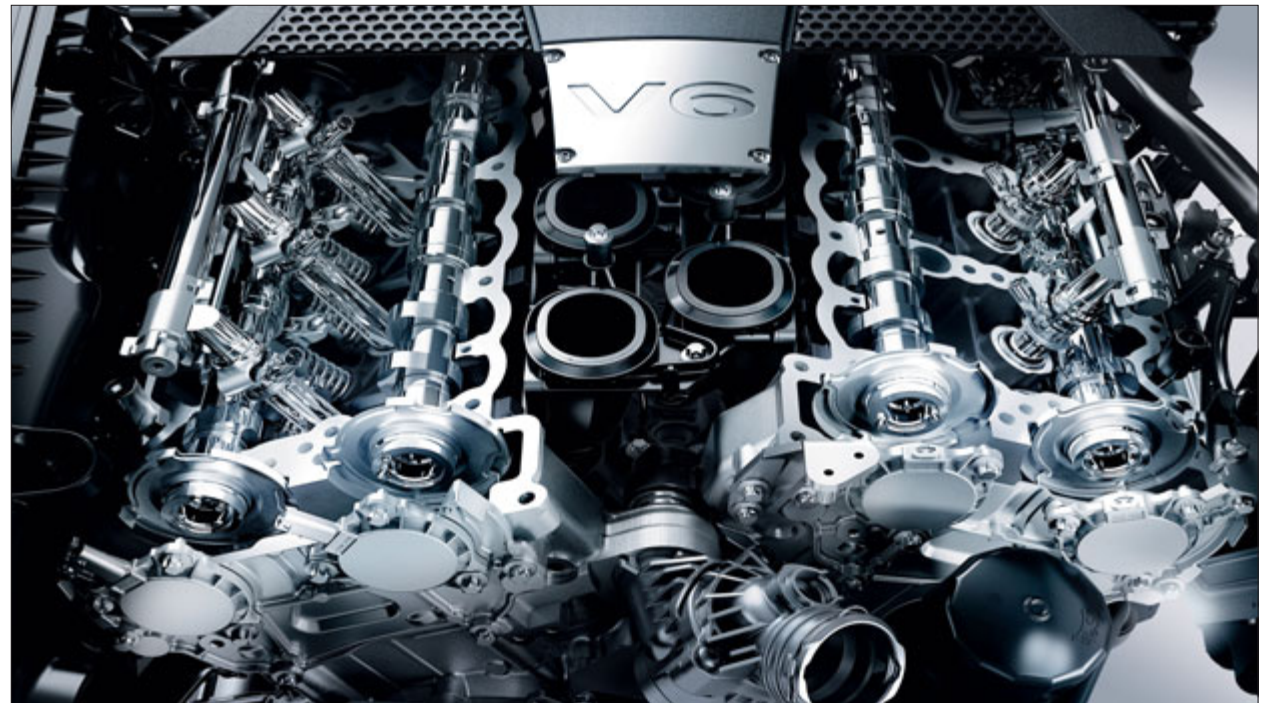

The engine of the CLS 350 BlueEFFICIENCY model can deliver high-torque power in every driving situation

V8 engine. Fitted in the CLS 500 BlueEFFICIENCY, the powerplant from the BlueDIRECT engine family impresses with a combined fuel-consumption figure of 9.0 litres per 100 kilometres (CLS Shooting Brake 9.3 –9.2 litres per 100 kilometres). Lightweight design, downsizing to a displacement of 4.7 litres as well as direct petrol injection with extremely fast and precisely controlled piezo injectors contribute to this, as do the innovative BlueEFFICIENCY technologies. The ECO start/stop function can stop the engine temporarily when the car is at a standstill. At the same time, the CLS 500 BlueEFFICIENCY and the CLS 500 4MATIC BlueEFFICIENCY offer extremely impressive driving dynamics thanks to twin turbochargers and an intercooler. An output of 300 kW (408 hp) and a peak torque of 600 Nm, which is on tap from just 1600 rpm, mean effortlessly superior motoring in almost any situation. The V8 engine boasts impressive power delivery, even at low engine speeds, not to mention levels of quietness and refinement which are exceptional for an eight-cylinder unit. The turbochargers ensure that the engine provides

high torque. This means that, to the driver, the V8 biturbo engine feels as comfortable and superior as a V8 naturally aspirated engine with a much higher displacement. The top-of-the-range engine for the CLS is in the CLS 63 AMG:

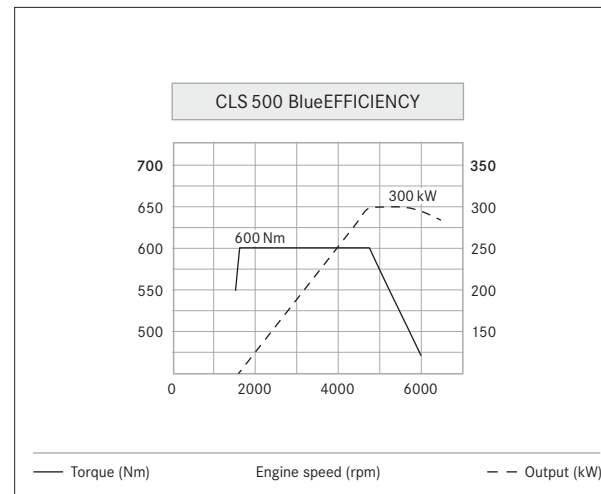

The CLS 500 BlueEFFICIENCY delivers a peak torque of 600 Nm between 1600 and 4750 rpm

the 5.5-litre V8 biturbo engine with up to 410 kW (557 hp) and 800 Nm.¹



The effortlessly superior V8 engine developing 300 kW (408 hp) is available for the CLS 500 BlueEFFICIENCY and CLS 500 4MATIC BlueEFFICIENCY models

¹ With Performance package. Only for CLS 63 AMG Coupé

Transmission

Whether it be an economical or a sporty driving style – the 7G-TRONIC PLUS has been optimised in line with the model in which it is installed. Plus it is intuitive and ergonomic to use.

7G-TRONIC PLUS. The CLS is fitted as standard with the 7G-TRONIC PLUS 7-speed automatic transmission and the DIRECT SELECT lever on the steering column. Shift paddles on the steering wheel enable the driver to influence the gear changes. Seven forward gears allow optimum revs, thus reducing fuel consumption. In city traffic especially, the 7-speed automatic transmission brings about a further reduction in fuel consumption thanks to the ECO start/stop function (not for the CLS 350 CDI BlueEFFICIENCY Coupé or CLS 350 CDI 4MATIC BlueEFFICIENCY Coupé), which stops the engine automatically when the car comes to a halt. The electrohydraulic control unit, together with the engine and transmission software, ensures exceptional gear-change dynamics and shift quality. The driver feels this in the car's more direct response to use of the accelerator pedal, for example.

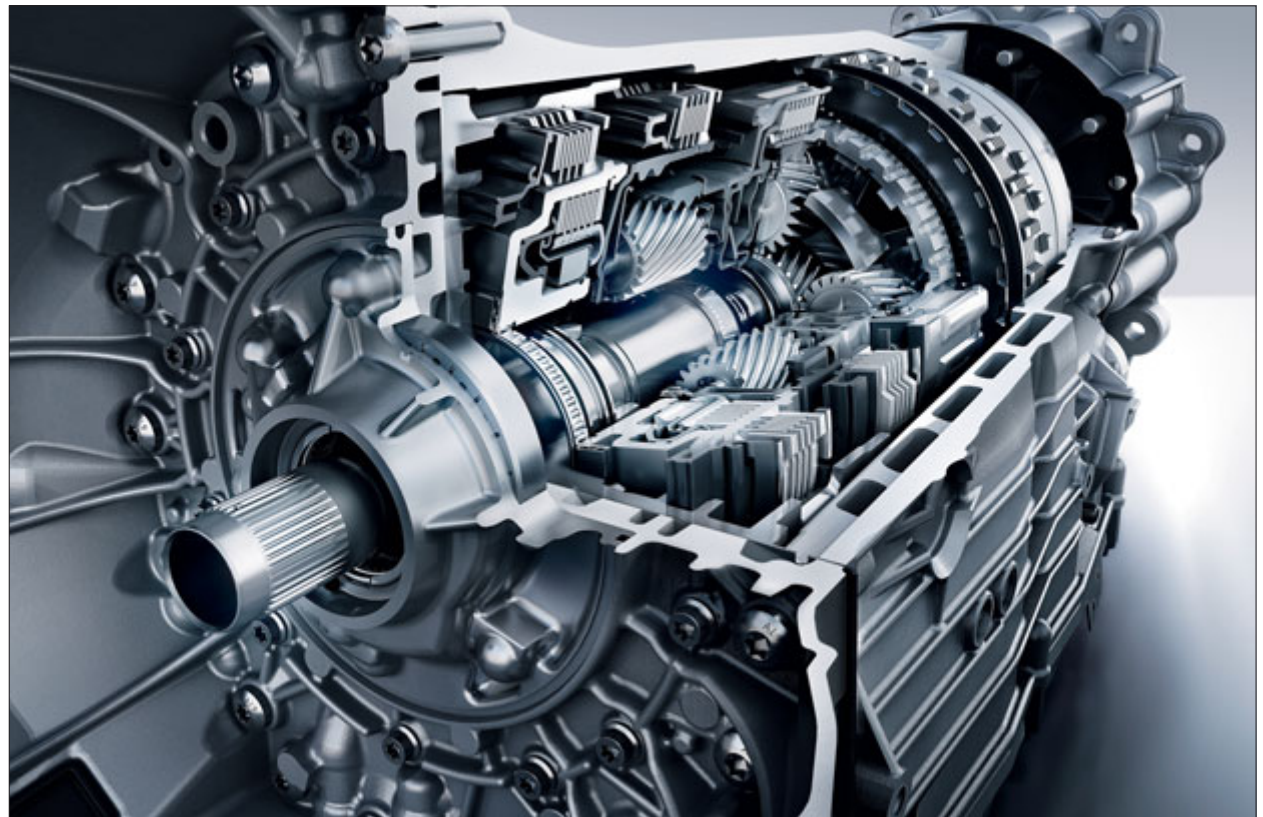

The 7G-TRONIC PLUS: one of over 18 million Mercedes-Benz automatic transmissions produced in a period spanning more than 50 years

Chassis & suspension

The permanent all-wheel drive system 4MATIC provides impressive traction as well as enhanced directional and driving stability. The chassis and the AIRMATIC air suspension really come into their own on the road, offering a high level of comfort yet also impressive agility.

4MATIC (option). The all-wheel drive system 4MATIC is always active, so it requires hardly any reaction time to intervene in unfavourable weather conditions such as rain, ice or snow. The 4MATIC is supported by the sensor system of the Electronic Stability Program ESP® and the electronic traction system 4ETS. 4ETS brakes spinning wheels in a targeted manner and thus steers the drive torque to the wheels with good traction. This makes dynamic moving off and accelerating easier – above all on a poor road surface.

4ETS renders conventional differential locks superfluous: the automatic braking pulses make moving off on slippery surfaces easier as well as enhancing stability during critical manoeuvres. A further advantage of the system is the fact that it is hardly any heavier than the rear-wheel drive version on account of the compact design and the intelligent choice of materials. The CLS 350 CDI 4MATIC BlueEFFICIENCY and CLS 500 4MATIC BlueEFFICIENCY models are fitted with four-wheel drive.

AIRMATIC (optional for 4- and 6-cylinder models, standard for 8-cylinder models). AIRMATIC air suspension with adaptive vibration dampers adapts to the road and driving conditions, reducing road roar and tyre vibration levels while enhancing active safety when compared with conventional steel suspension. The driver can select either comfort-oriented or sporty settings manually. At high speed, the car is lowered automatically to improve driving stability, aerodynamics and fuel consumption. The CLS Shooting Brake has air suspension with level control at the rear axle as standard.

DIRECT CONTROL suspension (standard for 4- and 6-cylinder models). The suspension with a selective damping system combines agility with ride comfort. The vibration dampers adapt automatically in line with the current driving situation, thus enhancing both damping and the car's stability – even on poor road surfaces.

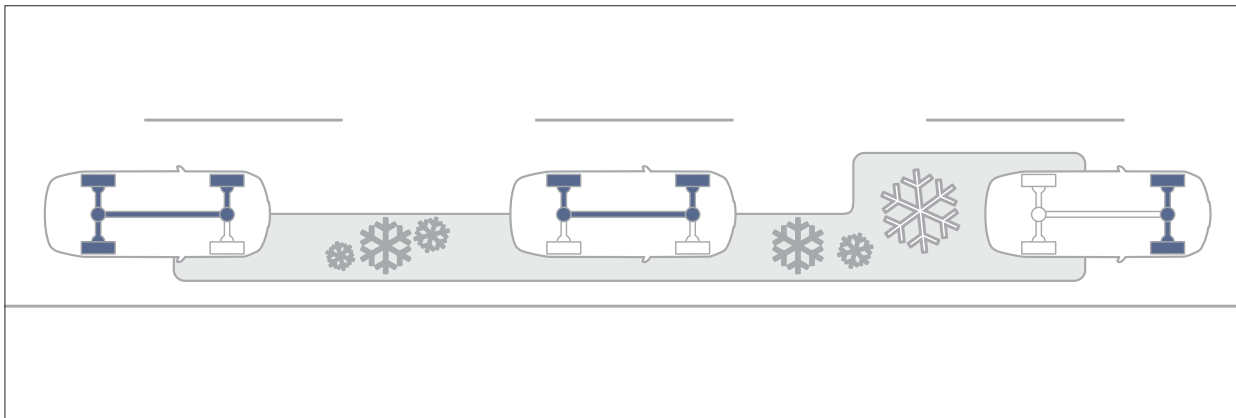

The electronic traction system 4ETS facilitates better traction in difficult conditions, such as when the road surface is wet or affected by ice or snow

Integral safety concept

The stated aim of accident-free driving drives us forward. Our integral safety concept brings us a step closer to achieving this aim – a comprehensive approach that can enhance safety in any situation.

As the inventor of the car we feel that we have a special responsibility for road safety. This is why we are the first car manufacturer to have developed an integral safety concept which seamlessly blends measures to enhance active and passive safety. The holistic approach is subdivided into four phases and offers safety solutions for every situation. It includes systems for safe driving which help to avoid risks by warning you and coming to your aid in good time. Our unique PRE-SAFE® system kicks in in the event of danger and activates preventive measures for occupant protection. If a collision should still occur in spite of all the preventive measures, further technologies ensure protection as needed. We have also borne in mind the time immediately following an accident and developed solutions which can help prevent worse and facilitate rapid help.

A selection of these technologies for the “Safe driving”, “In the event of danger”, “In an accident” and “After an accident” phases is presented on the pages which follow.

Safe driving: ATTENTION ASSIST (standard). This drowsiness-detection system is especially useful on long trips. At speeds of between 80 and 180 km/h, ATTENTION ASSIST warns the driver as soon as it detects signs of increasing inattention or drowsiness. Sensors analyse driving behaviour and can detect deviations from a previously determined, individual driver profile.



If signs of increased driver inattention or drowsiness are detected, ATTENTION ASSIST advises taking a break

Safe driving: Night View Assist Plus with clear heat-insulating windscreen (option). The central display shows the entire main-beam area – which the infrared camera of the Night View Assist records – as a greyscale image. This means better driver orientation in situations without main beam, so motorists can react earlier to people, animals or objects which are on or alongside the road.



To ensure better visibility, Night View Assist Plus highlights pedestrians on the display

Safe driving: Lane Tracking package (option). The Lane Keeping Assist can detect a lane using the road markings and warns the driver through gentle vibrations in the steering wheel if they are in danger of leaving the lane unintentionally. The Blind Spot Assist uses two radar sensors in the rear bumper to monitor the blind spot from a speed of 30 km/h, and can warn against dangerous lane changes.



Lane Keeping Assist and Blind Spot Assist can warn the driver in potentially dangerous situations

Driving Assistance package Plus (option). This package includes DISTRONIC PLUS proximity control as well as Active Lane Keeping Assist and Active Blind Spot Assist. DISTRONIC PLUS helps the driver to maintain the desired distance between the car and the vehicle in front by braking the car, to a standstill if necessary, and then accelerating it again. Active Blind Spot Assist monitors the areas to the left and right beside the car as well as to the side behind the car. If a vehicle is detected in the monitored area, a

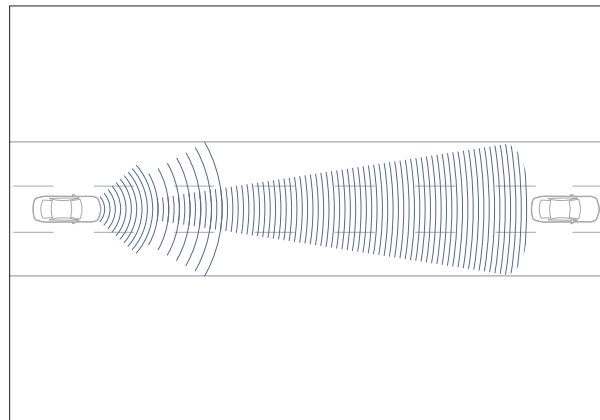

DISTRONIC PLUS proximity control can brake the car to a standstill then accelerate it again, for example when driving in a queue of traffic

symbol appears in the exterior mirror's glass to warn the driver. If the driver misses this warning, indicates and starts to change lanes despite a further, acoustic warning signal, the system can intervene actively via the ESP[®] control and correct the direction of travel moderately. Active Lane Keeping Assist monitors the lane markings continuously. If the system detects the vehicle unintentionally crossing the white markings, it warns the driver by making the steering wheel vibrate gently. If the driver fails to respond, the system can also actively brake the vehicle and prevent it from leaving its lane.

Safe driving: LED tail lights and adaptive brake lights (standard). The tail lights, brake lights and third brake light employ LEDs and emphasise the sporty design of the car. During emergency braking, the adaptive brake lights signal a hazardous situation to the traffic behind by flashing.

In the event of danger: PRE-SAFE® system (standard).

As a precaution, the PRE-SAFE® system can activate protective measures designed to prepare the occupants for a subsequent accident. Measures include reversible tensioning of the driver and passenger seat belts as well as automatic closing of the open windows and/or the optional sliding sunroof – depending on the driving situation and the vehicle equipment.

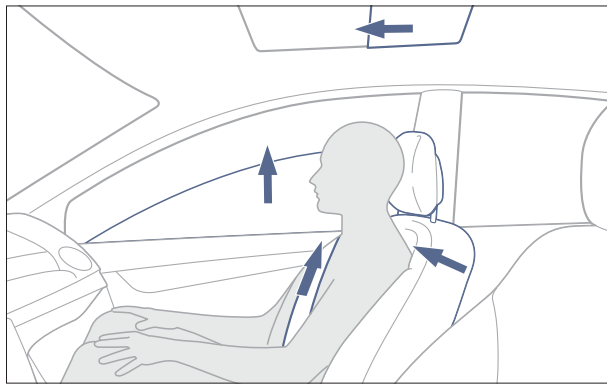

The anticipatory occupant protection system PRE-SAFE® can recognise critical driving situations and initiate preventive measures in order to protect the occupants

In the event of danger: PRE-SAFE® Brake (part of the optional Driver Assistance package Plus, optional in conjunction with DISTRONIC PLUS). As a three-stage warning and braking system, the PRE-SAFE® Brake can intervene prior to an impending rear-end collision: if there is no reaction from the driver following an initial visual and acoustic warning, the system can initiate autonomous partial braking as a tactile warning. If there is still no reaction from the driver, autonomous emergency braking can be initiated. The PRE-SAFE® Brake then reacts around 0.6 seconds before an accident deemed unavoidable and initiates emergency braking to reduce the impact speed and the severity of the collision.

In the event of danger: Brake Assist BAS PLUS (part of the optional Driver Assistance package Plus, optional in conjunction with DISTRONIC PLUS). Brake Assist BAS PLUS in conjunction with the PRE-SAFE® Brake can help to prevent rear-end collisions. The anticipatory system uses radar sensors to evaluate driving situations autonomously and, if needed, provides extra braking power based on the distance to the vehicle in front and the relative speed.

If the radar sensors detect a potential collision and the driver applies the brakes in time, BAS PLUS is primed to apply braking pressure in accordance with the available stopping distance. Furthermore, when the brakes are applied abruptly, the adaptive brake lights warn the traffic behind.

In an accident: restraint systems (standard). Nine airbags ensure that you are protected: the front airbags, which are deployed in two stages depending on the projected impact severity, sidebags and pelvisbags for the driver and front passenger plus windowbags. The kneebag can further reduce loads on the driver during an accident. As an option sidebags on the left and right in the rear are available. Seat belts are an essential part of occupant protection and become even safer through active elements. Electromotive belt tensioners at the front seats react fractions of a second before a potential accident and thus reduce the loads on the occupants.

In an accident: NECK-PRO head restraints (standard). These can be activated for the driver and front passenger during a rear impact, in accordance with the severity of the impact: a spring mechanism pulls them forwards and upwards. This means that the head can be supported earlier and the load on the cervical vertebrae reduced. In addition to this the high structural safety of the body and the highly stable occupant cell with various parallel load paths in the front and tail end ensure improved load

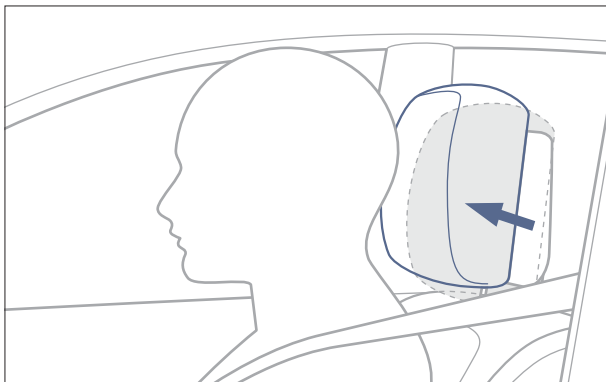

The NECK-PRO head restraints can reduce the risk of whiplash significantly in a rear impact

distribution during an impact, plus special side impact reinforcements in the doors see to it that the loads on the occupants remain as minimal as possible.

After an accident: Mercedes-Benz emergency call system (part of COMAND Online). This system can make an emergency call automatically using a mobile phone which is on standby and connected to the vehicle as soon as the restraint system detects an accident. At the same time,



The energy-absorbing crumple zones in the front and rear sections, an extremely robust safety passenger cell, and the doors with special reinforcing elements form an effective defensive barrier in an emergency

the GPS position data and other data about the vehicle are transmitted to the Mercedes-Benz emergency call centre, after which a voice connection is established. The emergency control system can also be triggered manually.

Measures after an accident. In order to reduce consequential damage and, where necessary, to support the rescue of the occupants, Mercedes-Benz has developed further measures. These include the automatic engine cut-off or the activation of the hazard warning lamps and interior emergency illumination. The central locking also opens automatically, and crash joints between the door and the wing make it easier to open the doors after a front impact. In addition Mercedes-Benz makes Guidelines for Rescue Services available; helpers can download them in different languages all over the world from the internet at www.mercedes-benz.de/rettungslaufplan. As you can see, at Mercedes-Benz consideration has been given to safety in every situation.

Light

Good visibility in the dark enhances driving comfort and, above all, safety. The CLS headlamps light up the road to optimum effect and even adjust in line with the course of the road.



LED High Performance headlamps with C-shaped side-marker lamps (option). The optionally available dynamic LED High Performance headlamps (standard on the CLS 63 AMG) in combination with an LED daytime driving light strip in the bumper covering are exciting developments in the lighting sector. The sophisticated, distinctive design of the LED High Performance headlamps emphasises the dynamism of the vehicle form and lends the front end an exceptionally high-quality character. In the dark, the headlamps are unmistakable on account of the C-shaped LED side-marker lamps. The LED technology combines maximum radiance with minimal energy consumption and a long lifetime. What's more, the light produced by the LED High Performance headlamps is very easy on the eyes, as its colour temperature of 5500 Kelvin makes it closer to daylight than the light produced by xenon headlamps.

The optional LED High Performance headlamps are one of the design highlights of the new CLS

LED Intelligent Light System (in conjunction with optional LED High Performance headlamps – standard on CLS 63 AMG). All five functions of the Intelligent Light System – country mode, motorway mode, enhanced fog lamps, cornering light function and active light function – have been combined with LED technology in the CLS. Adaptive Highbeam Assist ensures the best possible illumination of the road automatically in any driving situation.

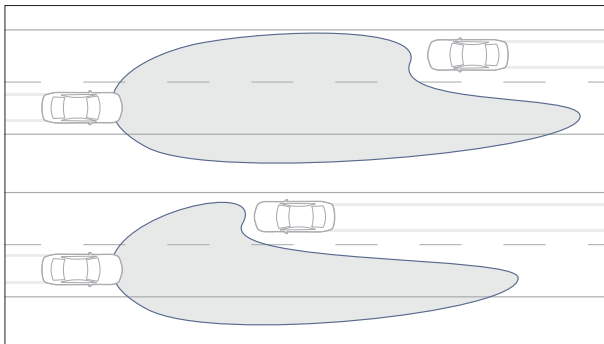

Adaptive Highbeam Assist always provides the best possible headlamp range automatically

Bi-xenon headlamps (standard). When set to low beam, the bi-xenon headlamps ensure better and wider illumination of the road verges. When switched to high beam, they have a much greater range than conventional headlamps. Dynamic, sensor-controlled range adjustment automatically compensates for any changes in the vehicle level when braking or accelerating.



The bi-xenon headlamps with circular daytime running lamps in the bumper come as standard

LED tail lights with night design (standard). The LED tail lights are drawn around into the car's flanks, giving the rear design its characteristic profile. The brake lights are based on the same look as the tail lights, and the luminosity of the LEDs is increased substantially during braking. Intermediate lenses highlight the contours even when the lights are switched off.



The LED tail lights dominate the rear view of the CLS

Multimedia systems

The multimedia functions in the CLS can be operated via an easy-to-use Controller located on the centre console. Alternatively you can use the buttons on the devices themselves or the multifunction steering wheel. The head units available for selection are the Audio 20 CD and COMAND Online.



COMAND Online is a combination of audio system, navigation system and telephone functions. All of the main settings can also be programmed using the LINGUATRONIC voice-operated control system

COMAND Online (option). The multimedia system boasts a high-resolution 17.8 cm colour display. The system's functions include a radio, speed-sensitive volume control, the MUSIC REGISTER with a 10 GB hard disc and hard-disc navigation. What's more, it also includes free European map data updates for 3 years following initial registration. The best in entertainment is provided courtesy of the DVD player, which can play CDs and MP3 files as well as video and audio DVDs. The online function facilitates access to the internet and various Mercedes-Benz mobile services via an internet-capable mobile phone. A USB connection, an Aux-in socket, a slot for SD memory cards and a Bluetooth® interface allow connection to external data storage media and a mobile phone. The system is operated using the central Controller and the buttons on the multifunction steering wheel. The Digital Owner's Manual contains the complete descriptions for operating the vehicle and the COMAND Online system. It can be called up quickly and easily via the system.

Audio 20 CD (standard). The Audio 20 CD radio features a 14.7 cm display, RDS/dual tuner with traffic information decoder, Bluetooth® interface and MP3-compatible CD player. A 6-disc CD changer is available as an option. All functions can be controlled conveniently using the multi-function steering wheel and the Controller on the centre console.



Audio 20 CD with optional Becker® MAP PILOT

Becker® MAP PILOT (option). The Becker® MAP PILOT allows the Audio 20 CD to be extended, making it a fully fledged vehicle-integrated navigation device. A GPS receiver and computer unit form part of the device. The Becker® MAP PILOT is secured in the glove compartment and can easily be taken out again. New map data are available via a simple update from the internet.

Harman Kardon® Logic 7® surround sound system (option). Equipped with 14 loudspeakers, including a sub-woofer, and a 9-channel DSP sound amplifier, this optionally available Dolby Digital 5.1 system has an output of 610 watts, giving you melodious acoustics in all seats when combined with the Audio 20 CD or the COMAND Online system. 3D surround sound and speed-sensitive volume control ensure constant listening pleasure.

Bang & Olufsen high-end sound system (option). This surround sound system with 14 high-performance loudspeakers in the CLS Shooting Brake/15 loudspeakers in the CLS Coupé and a newly developed DSP amplifier with 1200 watts ensures first-class acoustics. The surround sound playback can be individually adjusted throughout the entire passenger compartment. 3D surround sound and microphone-controlled sound-correction software ensure constant listening pleasure and maximum sound precision.



14/15 loudspeakers and 1200 watts delight the ears: the Bang & Olufsen high-end sound system

Assistance systems

Assistance systems are designed to make life easier. In this respect, Speed Limit Assist, the reversing camera and Active Parking Assist enhance the feeling of comfort and safety in the CLS.



Speed Limit Assist even indicates temporary speed limits

Speed Limit Assist (option in conjunction with COMAND Online). Speed Limit Assist can detect speed-limit signs by means of a windscreen-mounted camera and display them as symbols on the instrument cluster. The camera filters out circular speed-limit signs, regardless of whether they are at the side of the road or on a gantry above the road. Speed Limit Assist is especially helpful on routes with variable-message signs or road works. In addition, this system compares the displayed speed limits – such as when entering or leaving towns – with the data stored in the navigation system and shows the driver whether the car is travelling within the speed limit.

Reversing camera (option in conjunction with COMAND Online). The reversing camera monitors the area directly behind the car with its wide-angle lens and sends the images to the central COMAND display. It is activated automatically when reverse gear is engaged, thus helping the driver when reversing.



During parking, the COMAND Online central display shows the area behind the car

Active Parking Assist, including PARKTRONIC (option). With the Active Parking Assist from Mercedes-Benz the vehicle looks for a suitable parking space by itself and automatically parks the car at the press of a button, whilst the driver only needs to actuate the accelerator and brake pedal as soon as they have stopped, accepted the parking space suggestion and engaged reverse gear. The Active Parking Assist deals with the steering on its own. The system



The display in the instrument cluster gives you a clear picture of the parking manoeuvres at all times

works extremely precisely: for the automatic parking procedure the parking space has to be approximately 1.30 metres longer than the vehicle. The PARKTRONIC's ultrasonic sensors measure the distance from the vehicle at the front and rear during the automatic parking process. The Active Parking Assist system uses a total of ten ultrasonic sensors, six in the front and four in the rear bumper, plus there is an electronic control unit which processes the sensor signals and calculates the optimum route into the parking space.

Seats

In terms of style, the link between the interior and exterior design of the CLS is seamless. The aesthetic individuality continues inside the car, adding distinctive touches and thus enhancing driving enjoyment.



The active multicontour seats are designed to meet the highest requirements in terms of individual seating comfort, ergonomics and safety

The interior design picks up on the themes of the exterior design. For instance, the “dropping line” shaping of the door linings reflects the exterior’s dynamic, forward-thrusting side line, while the feeling of momentum generated by the centre console is mirrored in the doors and the beltline, thus giving the occupants a feeling of security. This feeling is further enhanced by elegant topstitching as well as the use of high-quality and authentic materials such as leather, wood and piano lacquer, depending on the interior appointments selected by the customer.

Memory package (option, standard in the CLS 63 AMG). The Memory package enhances convenience if several different people drive the car or sit in the front-passenger seat. A control panel is used to move the front seats, head restraints, steering column and exterior mirrors. Three different groups of settings can be stored for each seat. The integral, electrically adjustable 4-way lumbar support allows each seat occupant to select their preferred settings.

Active Multicontour Seat package (option). The active multicontour seat with massage and dynamic functions for the driver and front passenger helps to ensure a comfortable ride on long trips. The seat contours can be adjusted to suit individual body shapes using the COMAND Controller. What's more, the active multicontour seat adjusts dynamically in accordance with the driving situation. The NECK-PRO luxury head restraints for the front seats are integrated here.



The active multicontour seats with massage and dynamic functions

NECK-PRO luxury head restraints (option in conjunction with Multicontour Seat package and Active Multicontour Seat package). The flexible side bolsters of the luxury head restraints improve lateral support of the head and enhance comfort. Furthermore, the head restraints are activated by means of sensor control if a rear impact is detected. They are then moved into a better position to reduce the risk of whiplash injuries. Following deployment the head restraint can be pushed back into the original position manually.



The NECK-PRO luxury head restraints can reduce the risk of whiplash injuries

Single seats in the rear (standard in the CLS Coupé). The luxurious ambience in the interior of the CLS is underlined by the shape, colour scheme and material of the seats. The individuality of the design is once again emphasised – by the single seats in the rear, which are separated from one another by a centre console with a folding armrest. The vertical fluting elements in the seat surfaces and backrests lend the seats their unmistakable profile. In the CLS Shooting Brake there is a fifth seat instead of the centre console.

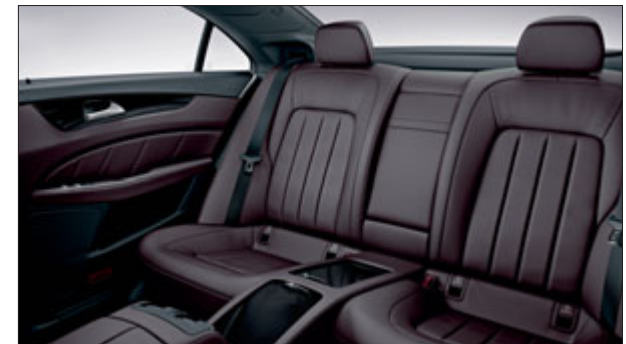

Comfortable single seats await the rear passengers in the CLS Coupé

Space

A dream of a load compartment: the new CLS Shooting Brake is a shining example with its particularly elegant luggage area.



The optionally available designo wood floor made of open-pore American cherry, featuring black work

Load compartment. Particular attention was given to the design of the luggage area of the CLS Shooting Brake. By way of example, on request you can have a fine designo wood floor made of open-pore American cherry and featuring black work. It is ideally matched to the interior design and lends the interior of the vehicle maximum high-class appeal. Exclusive details, such as trimmed belt-lines with lavish stitching, add to the harmonious overall effect.

Anything that looks this good should stay neat and tidy, which is where side nets for the practical storage of smaller items come in useful. And where variability is writ large, comfort is never far away. For the new CLS Shooting Brake is fitted as standard with the EASY-PACK tailgate. At the touch of a button a motor takes care of the automatic opening and closing of the tailgate, which makes loading and unloading so much easier.

Designer aluminium rails (option). The designer aluminium rails on the load compartment floor increase the high-class appeal of the load compartment and ensure additional non-slip properties – important when transporting loads.



Optional extra: designer aluminium rails on the load compartment floor

EASY-PACK load-securing kit (option). With the EASY-PACK load-securing kit the load compartment can be variably subdivided into individual segments. Items can be secured for transporting using a telescopic rod. The optional load-securing net offers additional protection against objects in the load compartment.



Load compartment with optional EASY-PACK load-securing kit

Variability. More space with one simple action: the optional EASY-PACK quickfold (standard in the CLS Shooting Brake) makes loading easier for you. With operating levers at the left and right in the load compartment the rear seat backrests can be folded either as a whole or, if required, also separately. Thanks to TIREFIT there are 130 litres of additional stowage space beneath the load compartment floor where the spare wheel would normally be. For electronic devices there is a 12 V socket.



Rear seat backrest with a single-seat character, folded 2/3

CLS 63 AMG exterior

AMG – three letters that are internationally synonymous with leading-edge technology, exclusivity and refined sportiness. The unique experience begins before you even get into the CLS 63 AMG – as you savour the exterior design. → www.mercedes-amg.com

Just looking at the car is an electrifying experience in itself: from the exclusive AMG bonnet design to the AMG spoiler lip on the boot lid of the coupé, the CLS 63 AMG impresses with its hallmark, energetically expressive AMG appearance. This model combines the distinctive aura of the CLS with the design of a sports car: the unique wide front wings,

the single-louvre radiator and the powerful AMG front apron combine with the LED High Performance headlamps and exclusive AMG LED daytime running lamps integrated in the outer air dams to create a symbol of thrilling dynamism. This momentum is underlined by triple-spoke AMG light-alloy wheels painted in titanium

grey with a high-shine finish, the exclusive AMG diffuser-style rear apron with an integral rear fog lamp and, of course, the AMG sports exhaust system with chromed twin tailpipes.



CLS 63 AMG with LED High Performance headlamps



AMG sports exhaust system with chromed twin tailpipes



Triple-spoke AMG light-alloy wheels



The exclusive AMG aura lends the vehicle an even more dynamic appearance

CLS 63 AMG interior

One look at the interior of the CLS 63 AMG is all it takes to realise what the Mercedes-AMG experts mean by “custom-designed dynamism”.

The interior of the CLS 63 AMG is an exciting blend of fine materials, refined craftsmanship and consistently sporty design. At the heart of the cockpit is the AMG DRIVE UNIT with its E-SELECT lever and AMG emblem, which can be used for individual control of transmission modes, ESP® functions and suspension set-ups. Above this is the new AMG 3-spoke performance steering wheel with flattened

top and bottom sections, equipped with silver-coloured aluminium shift paddles, and the AMG instrument cluster with its AMG main menu including RACETIMER. These sporty attributes are blended with exclusive agility: ergonomic AMG sports seats in nappa leather, brushed stainless steel for the AMG door sill panels and the AMG sports pedals, which also feature non-slip rubber studs.

A black piano lacquer trim and an analogue clock in an exclusive IWC design complete the impression of style-conscious sportiness. Maximum performance for the ears is promised by the optional 1200-watt Bang & Olufsen BeoSound AMG high-end sound system with 14 loudspeakers in the CLS Shooting Brake and 15 loudspeakers in the CLS Coupé.



The AMG performance steering wheel and the AMG instrument cluster



The AMG DRIVE UNIT is at the heart of the cockpit



The optional Bang & Olufsen BeoSound AMG high-end sound system



The interior of the CLS 63 AMG features a thrilling mix of fine materials and sporty design

CLS 63 AMG technology

The AMG 5.5-litre V8 biturbo engine and the AMG SPEEDSHIFT MCT 7-speed sports transmission make for emotive driving experiences and outstanding efficiency. Yet when it comes to choosing a sporty or comfort-oriented driving style, the driver always has the final say in the CLS 63 AMG.

AMG 5.5-litre V8 engine. The twin-turbocharged AMG V8 in the CLS 63 AMG impresses on two counts above all: its exciting dynamism and a level of efficiency that is nothing short of extraordinary in this output category. As you might expect from Mercedes-AMG, it produces a characteristic, powerful sound – with a rated output of up to 410 kW (557 hp) and a peak torque of 800 Nm when the optional AMG Performance package (only for CLS Coupé) is on board. The low fuel consumption for this output category is achieved courtesy of direct petrol injection with spray-guided combustion, twin turbochargers,



Motor-racing technology gives the AMG 5.5-litre V8 engine maximum agility

alternator management and the Controlled Efficiency mode with its ECO start/stop function among other things.

AMG SPEEDSHIFT MCT 7-speed sports transmission. Bringing you the best of both worlds: the sporty, direct and agile feedback of a manual transmission paired with the outstanding convenience of an automatic. Yet the high-tech transmission still gives the driver a free hand as, in addition to the “Race Start” and automatic double-declutching functions, it offers a further four individual modes: Controlled Efficiency – or “C” for short – stands for



The AMG SPEEDSHIFT MCT 7-speed sports transmission offers customised modes for maximum driving pleasure

extremely consumption-optimised driving, while the “S” (Sport), “S+” (Sport Plus) and “M” (Manual) modes enhance dynamism. They allow gear changes in under 100 ms thanks to the partial suppression of individual cylinders when upshifting. A compact, wet clutch in place of the conventional torque converter translates accelerator pedal movements into forwards thrust instantaneously.

AMG RIDE CONTROL sports suspension. The wider front axle used for the AMG sports suspension enhances lateral dynamics substantially, while the electronically controlled damping system on the rear axle allows lightning-fast changes in the set-up, depending on whether maximum agility or ultimate ride comfort is required. The AMG RIDE CONTROL sports suspension also offers an impressive array of individualisation options, allowing the driver to select from a range of suspension modes: “Comfort”, “Sport” and “Sport Plus”.

Furthermore, it gives the driver the option of switching the ESP® dynamic handling control system to “ON”, “SPORT HANDLING” or “OFF” mode. The AMG speed-sensitive sports steering has an even more direct ratio and, therefore, offers outstanding steering precision and direct turn-in ability. The AMG high-performance brake system with 360 mm brake discs ensures outstanding levels of deceleration and fade resistance. The front brakes deliver exceptional performance thanks to the same compound technology as that used in motorsport and large 6-piston callipers.



AMG Performance Studio

The AMG Performance Studio brings the sporty traits of the CLS 63 AMG even further to the fore, in terms of both performance and aura, by offering a wide range of attractive individualisation options.

To further emphasise the sporty side of the CLS 63 AMG, the AMG Performance Studio offers the AMG Performance package (only for CLS Coupé) – it raises the power to 410 kW (557 hp) rated output and 800 Nm peak torque. And it does not just enhance the performance of the CLS 63 AMG on a visual level thanks to the AMG carbon-fibre engine cover, an AMG carbon-fibre spoiler lip, the red-painted



The AMG performance steering wheel with DINAMICA microfibre inserts

AMG brake callipers and the AMG performance steering wheel with DINAMICA microfibre inserts. Further optional extras include an AMG trim in carbon fibre/piano lacquer, illuminated door sill panels, an AMG Exterior Carbon-Fibre package and 5-twin-spoke AMG forged wheels. Not to mention an AMG RIDE CONTROL performance suspension with even firmer tuning in all three suspension modes for



AMG ceramic high-performance compound brakes

the CLS Coupé. The optional AMG rear-axle differential lock facilitates even better traction. The large AMG ceramic high-performance compound brakes are instantly recognisable by their specially painted callipers. They offer a precise pressure point, outstanding resistance to fading and exceptionally short stopping distances whilst reducing system weight by around 40%.

And for all those who desire even more dynamism, there is the AMG Driver's package, which gives an electronically governed top speed of 300 km/h (in the case of the CLS Shooting Brake 280 km/h). Participation in driver training at the AMG Driving Academy is also included.

The AMG Performance Studio in Affalterbach can also meet other customer requests – including the production of one-off models.



High performance even when at a standstill: the CLS 63 AMG Coupé with the AMG Performance package

Standard equipment | Selection



3-spoke multifunction steering wheel in nappa leather



Audio 20 CD



Cruise control



EASY-PACK quickfold (option for the CLS Coupé)



THERMATIC automatic climate control



DIRECT SELECT lever with shift paddles on the steering wheel



Analogue clock



ISOFIX child seat attachment points in rear



Bi-xenon headlamps with daytime running lamps (switched off)



EASY-PACK tailgate (only for CLS Shooting Brake)



LED tail lights



Load compartment cover (only for CLS Shooting Brake)

Optional extras | Selection



KEYLESS-GO package (incl. start/stop button)



COMAND Online with colour display (17.8 cm screen diagonal)



Climatised seats



Active Parking Assist with PARKTRONIC



Ambient lighting adjustable to three colours



THERMOTRONIC automatic climate control¹



Memory package for storing three seat positions²



EASY-PACK load-securing kit with aluminium rails (only for CLS Shooting Brake)



LED High Performance headlamps with LED daytime running lamps²



Dark-tinted glass at the rear and side windows from B-pillar (only for CLS Shooting Brake)



Sliding glass sunroof



EASY-PACK boot box (for CLS Coupé only)

Exclusive package

An interior with a hand-crafted look: the optionally available Exclusive package adds elegant touches by using the finest materials and stylish colour shades.

All of the CLS interior colours are available for the optional Exclusive package. The roof lining, the pillar mouldings and the sun visors are trimmed in DINAMICA microfibre, while the velour floor mats feature a nubuck strip in the same colour as the appointments. To complement the

high-quality Exclusive PASSION leather upholstery, the dashboard, beltline, armrests, head restraints, centre console and door centre panels are trimmed in nappa leather. The ambient lighting with three selectable colours sets everything in the right light, while a wood/leather

steering wheel is available as an option. The Exclusive package can be combined with the Exterior Sports package or the AMG Sports package.



The ambient lighting



Trim on the dashboard



The optionally available wood/leather steering wheel



The luxury appointments in Exclusive PASSION leather with the dashboard trimmed in nappa leather in the Exclusive package

Exterior Sports package

Should you wish to add carefully selected details to further emphasise the athletic character of your CLS, the optional Exterior Sports package could be just what you are looking for.



5-spoke light-alloy wheel, painted in anthracite (Code R36, or in silver on request, Code R32)



5-twin-spoke light-alloy wheel (Code R17)



5-spoke light-alloy wheel (Code 22R)



10-spoke light-alloy wheel, painted in himalayas grey (only for CLS Shooting Brake, Code 656)

Visual highlights are provided by the rectangular tailpipe trims integrated in the bumper, finished in chrome on both sides. The sporty side of the CLS is given further emphasis by attractive 5- and 10-spoke light-alloy wheels in silver, anthracite or himalayas grey and mixed-size tyres as well as the black-painted rear-bumper insert.

The Exterior Sports package makes your CLS look even more irresistible, while the steel suspension is fine-tuned with firmer dampers to make it even more sporty (not in conjunction with AIRMATIC air suspension).



Exterior Sports package with 5-spoke light-alloy wheels in silver (Code R82), or painted in anthracite on request (Code 49R)

AMG Sports package

Get your CLS into tip-top shape. The sporty and athletic styling elements in the optionally available AMG Sports package lend your car extra dynamism all round.

The powerful AMG front apron, the AMG rear apron with integral chrome trim and the single-louvre radiator grille take the look of the CLS up another gear. The 4- and 6-cylinder models get a two-pipe sports exhaust system with visible, chromed tailpipe trims integrated in the rear apron. The steel suspension is firmer and more sporty. 5-spoke AMG light-alloy wheels with a high-sheen finish and mixed-size tyres (front 255/40 R 18 and rear 285/35 R 18) round off the dynamic exterior. Larger AMG light-alloy wheels with mixed-size tyres (front 255/35 R 19 and rear 285/30 R 19) are available as optional extras. The interior

is dominated by the 3-spoke multifunction sports steering wheel in black nappa leather (in almond beige if almond beige appointments are ordered) with a flattened bottom section, including shift paddles. The E/S/M switch allows the driver to select an economical, sporty or manual transmission mode. Floor mats with AMG lettering, sports pedals in brushed stainless steel with rubber studs, and the distinctive, bright contrasting topstitching in conjunction with the optional black upholstery in leather, PASSION leather or Exclusive PASSION leather complete the sporty interior.

The 8-cylinder CLS 500 BlueEFFICIENCY and CLS 500 4MATIC BlueEFFICIENCY models are equipped as standard with sports pedals, an AMG front apron, single-louvre radiator grille, AMG rear apron with integral chrome trim and a two-pipe sports exhaust system.



The tail end of the CLS with the AMG Sports package



3-spoke multifunction sports steering wheel in nappa leather



Sporty elegance in the interior



The CLS in top form with the optional AMG Sports package

designo



The interior with platinum white designo leather and trim in high-gloss black piano lacquer



The exterior in designo graphite paintwork



The exterior in designo mystic blue paintwork



X06



X35

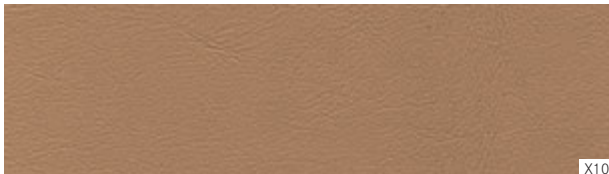

X10



X39

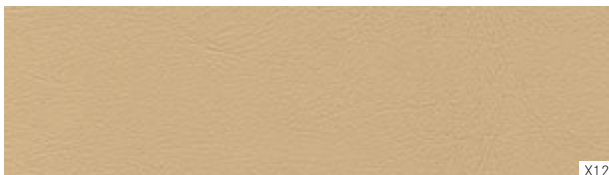

X12



X40

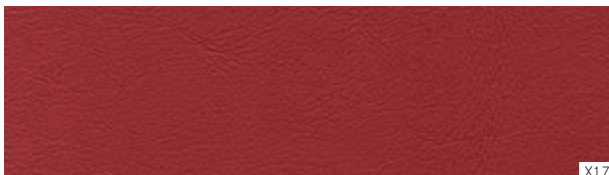

X17

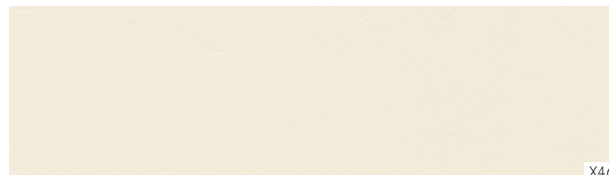

X46

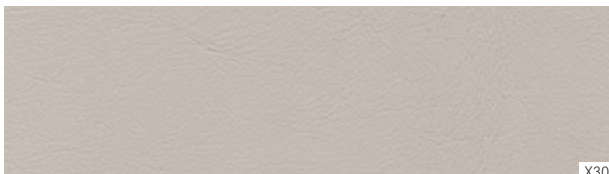

X30

Individuality at its most alluring: with the optionally available designo range you can add the finishing touches to the inimitable design of your CLS. The exclusive selection offers discerning customers a series of attractive colour shades for the upholstery in designo leather plus impressive special paint finishes and trim.

→ www.mercedes-benz.com/designo

designo leather¹

- X06 designo marron leather
 - X10 designo sand leather
 - X12 designo pastel yellow leather
 - X17 designo classic red leather
 - X30 designo platinum white leather
 - X35 designo light brown leather
 - X39 designo jet black leather
 - X40 designo mystic blue leather
 - X46 designo deep white leather
-

¹ Optional extra

Upholstery and trim





For the black colour scheme, there is a choice between seat covers in ARTICO man-made leather/fabric (standard) or optional seat upholstery in leather (standard for CLS 500 BlueEFFICIENCY and CLS 500 4MATIC BlueEFFICIENCY), PASSION leather or Exclusive PASSION leather, depending on the model. In this case, the interior (seat covers, steering wheel, dashboard) is largely in black and depending on the model has contrasting grey or black (AMG Sports package) surfaces for the roof lining and the B- and C-pillars. The Exclusive PASSION leather appointments also include an additional leather trim for the dashboard.



701

201

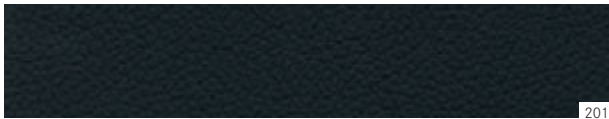
801
501

H19



731



736



H21

black

- 701 ARTICO man-made leather/fabric
- 201 Leather¹
- 801 PASSION leather¹
- 501 Exclusive PASSION leather^{1,2}

Trim

- H19 satin-finish light brown poplar wood
 - 731 high-gloss brown burr walnut wood¹
 - 736 high-gloss black ash wood¹
 - H21 black piano lacquer¹
-

¹ Optional extra ² Only in conjunction with Exclusive package



The almond beige colour scheme includes optional upholstery in leather (standard for CLS 500 BlueEFFICIENCY and CLS 500 4MATIC BlueEFFICIENCY), PASSION leather or Exclusive PASSION leather, depending on the model. The seat covers, steering wheel, the lower section of the dashboard, roof lining, door centre panels and carpet as well as A- and C-pillars are all in almond beige. The Exclusive PASSION leather appointments also include an additional leather trim for the dashboard.

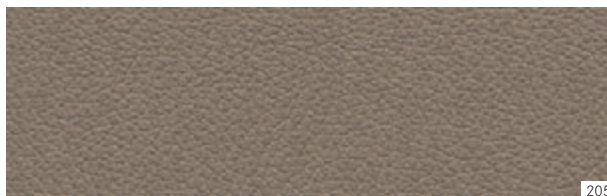

205



H19

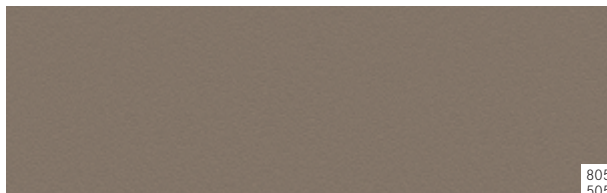

731

805
505

736



H21

almond beige

205 Leather¹805 PASSION leather¹505 Exclusive PASSION leather^{1,2}

Trim

H19 satin-finish light brown poplar wood

731 high-gloss brown burr walnut wood¹736 high-gloss black ash wood¹H21 black piano lacquer¹

¹ Optional extra ² Only in conjunction with Exclusive package



The black/aubergine colour scheme includes optional upholstery in leather, PASSION leather or Exclusive PASSION leather, depending on the model. The steering wheel, roof lining, beltlines and carpet plus A-, B- and C-pillars are all in black, while the seats are in contrasting aubergine. To complement these appointments, the lower section of the dashboard, the front and rear of the centre console, the door centre panels, and the armrests are also in the same colour. The Exclusive PASSION leather appointments also include an additional leather trim for the dashboard.

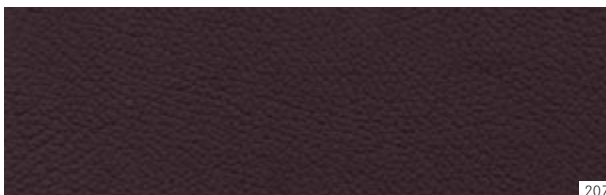

207



H19



731

807
507

736



H21

black/aubergine¹

- 207 Leather¹
 - 807 PASSION leather¹
 - 507 Exclusive PASSION leather^{1,2}
-

Trim

- H19 satin-finish light brown poplar wood
 - 731 high-gloss brown burr walnut wood¹
 - 736 high-gloss black ash wood¹
 - H21 black piano lacquer¹
-

¹ Optional extra ² Only in conjunction with Exclusive package



The alpaca grey colour scheme includes optional upholstery in leather (standard for CLS 500 BlueEFFICIENCY and CLS 500 4MATIC BlueEFFICIENCY), PASSION leather or Exclusive PASSION leather, depending on the model. The seats, roof lining, the lower section of the dashboard, door centre panels, carpet plus A-, B- and C-pillars are all in alpaca grey, while the beltlines, the upper section of the dashboard and the steering wheel are in contrasting black. The Exclusive PASSION leather appointments also include an additional leather trim for the dashboard.

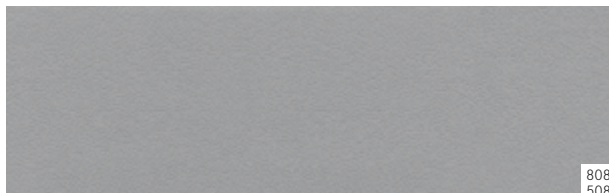

208

808
508

H19



731



736



H21

alpaca grey

208 Leather¹808 PASSION leather¹508 Exclusive PASSION leather^{1, 2}

Trim

H19 satin-finish light brown poplar wood

731 high-gloss brown burr walnut wood¹736 high-gloss black ash wood¹H21 black piano lacquer¹

¹ Optional extra ² Only in conjunction with Exclusive package



The black/porcelain colour scheme includes optional upholstery in leather, PASSION leather or Exclusive PASSION leather, depending on the model. The steering wheel, roof lining, beltlines, carpet plus A-, B- and C-pillars are all in black, while the seats, door centre panels and the lower section of the dashboard are in contrasting porcelain. The Exclusive PASSION leather appointments also include an additional leather trim for the dashboard.

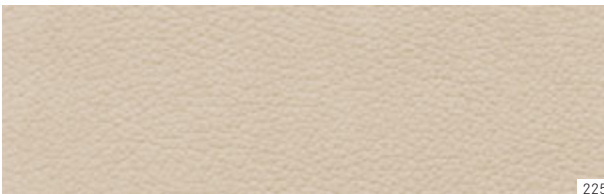

225



H19



731

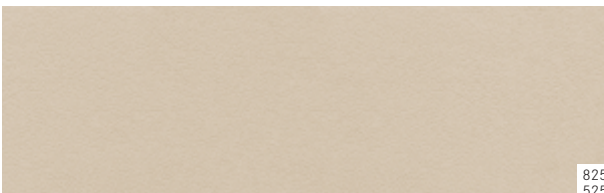

825

525



736



H21

black/porcelain¹

- 225 Leather¹
 - 825 PASSION leather¹
 - 525 Exclusive PASSION leather^{1, 2}
-

Trim

- H19 satin-finish light brown poplar wood
 - 731 high-gloss brown burr walnut wood¹
 - 736 high-gloss black ash wood¹
 - H21 black piano lacquer¹
-

¹ Optional extra ² Only in conjunction with Exclusive package

Wheels



10-spoke light-alloy wheels with 245/45 R 17 tyres (standard for CLS 250 CDI BlueEFFICIENCY, Code 25R), not available for the CLS Shooting Brake)



5-spoke light-alloy wheels with 255/40 R 18 tyres (optional for 4- and 6-cylinder models, standard for CLS 500 BlueEFFICIENCY and CLS 500 4MATIC BlueEFFICIENCY, Code R96)



15-spoke light-alloy wheels with 255/40 R 18 front and 285/35 R 18 rear tyres (optional, Code R34)



5-twin-spoke light-alloy wheels with 255/35 R 19 front and 285/30 R 19 rear tyres, painted in himalayas grey with a high-sheen finish (optional, Code R17)



10-spoke light-alloy wheels with 245/45 R 17 tyres (standard for 6-cylinder models and CLS 250 CDI BlueEFFICIENCY Shooting Brake, optional for CLS 250 CDI BlueEFFICIENCY Coupé, Code R43)



5-twin-spoke light-alloy wheels with 255/40 R 18 front tyres and 285/35 R 18 rear tyres, painted in himalayas grey with a high-sheen finish (optional, Code 22R)



5-spoke light-alloy wheels with 255/40 R 18 front and 285/35 R 18 rear tyres, painted in silver (standard for Exterior Sports package, Code R32, in anthracite Code R36)



5-twin-spoke light-alloy wheels with 255/40 R 18 front and 285/35 R 18 rear tyres, painted in titanium silver (optional, Code R70)



5-spoke light-alloy wheels with 255/35 R 19 front and 285/30 R 19 rear tyres, painted in silver (optional, Code R82, in anthracite Code 49R, for Exterior Sports package)



10-spoke light-alloy wheels with 255/35 R 19 front and 285/30 R 19 rear tyres, painted in himalayas grey (optional, only available for CLS Shooting Brake, Code 656)



5-spoke AMG light-alloy wheels with 255/35 R 19 front and 285/30 R 19 rear tyres, painted in titanium silver with a high-sheen finish (optional, Code 770)



Triple-spoke AMG light-alloy wheels with 255/35 R 19 front and 285/30 R 19 rear tyres, painted in titanium grey with a high-sheen finish (standard for CLS 63 AMG, Code 797)



10-spoke light-alloy wheels with 255/35 R 19 front and 285/30 R 19 rear tyres, painted in titanium silver and with a high-sheen finish (optional, Code R97)



5-spoke AMG light-alloy wheels with 255/40 R 18 front and 285/35 R 18 rear tyres, painted in titanium grey with a high-sheen finish (standard for AMG Sports package, Code 790)



10-spoke AMG light-alloy wheels with 255/35 R 19 front and 285/30 R 19 rear tyres, painted in matt black with a high-sheen finish (optional for CLS 63 AMG, Code 752)



Twin-spoke AMG forged wheels with 255/35 R 19 front and 285/30 R 19 rear tyres, painted in titanium grey with a polished surface (optional for CLS 63 AMG, Code 793)

Genuine accessories

A Mercedes-Benz can be a travel companion, an office or a living space. To make even better use of this diversity, the Mercedes-Benz range of genuine accessories has been fully customised for the CLS.



Rear Seat Entertainment System. The elegant DVD system allows your favourite films, images and even video games¹ to be shown on two brilliant 17.8 cm LCD colour screens. The rear passengers can view a film together or each watch their own choice of content thanks to separate DVD players. In addition to this, you can use further storage media via the USB interface or SD card slot. The Rear Seat Entertainment System requires no pre-installations at the factory whatsoever and can be retrofitted easily.

With the Rear Seat Entertainment System, your enjoyment doesn't have to take a back seat (also available as optional extra Code E78)

¹ External devices such as games consoles can be connected

incenio light-alloy wheels. The flamboyant high-end design of the incenio light-alloy wheels underlines the effortlessly superior presence of the CLS. The light-alloy wheels come in a range of different sizes and designs, such as 10-spoke wheels painted in black with a high-shine finish paired with mixed-size tyres (front 255/35 R 19 and rear 285/30 R 19).



incenio light-alloy wheels painted in black

Door sill panels. Characteristic features include the door sill panels in brushed stainless steel, which set off the Mercedes-Benz lettering in white to stunning effect. The rails protect the entrance area and with their elegant engraving they make a fine impression.



Door sills with Mercedes-Benz lettering (also available as optional extra Code E13)

In our accessories brochure you will also find a wide selection of high-quality items covering practically every aspect of your vehicle. What you see here is just a small selection of what is on offer. Your authorised Mercedes-Benz dealer will also be pleased to advise you.

Services

MercedesCard. As a VISA credit card, this is an internationally accepted means of payment that can offer you a host of additional benefits, such as the Mercedes-Benz insurance package or other exclusive insurance products. There's also the Mercedes-Benz magazine to inspire you with its fascinating features and reports. Further details are available from your Mercedes-Benz dealer.

Mercedes-Benz Financial Services. Mercedes-Benz stands for quality, innovation and safety – and the same applies to Mercedes-Benz Financial Services. Our innovative leasing and financing products are tailored to your financial needs and means, making it easy for you to secure the keys to your dream car. Once you are on the road, our insurance products offer you comprehensive protection on every trip. Finally, our service products ensure that your car is always in tip-top condition while keeping costs transparent and easily manageable. For a detailed quotation, please contact your authorised Mercedes-Benz dealer, who will be pleased to go through the latest financial services and terms and conditions with you.

Mercedes-Benz mobility. Your new car comes complete with the promise of feeling safe on the road. But if you should ever need assistance, Mercedes-Benz Service24h is there to help. Just call the freephone service hotline on 00800 1 777 7777¹. The integrated telematics service, Mercedes-Benz Contact², is even more convenient: a touch of a button is all it takes to contact the Mercedes-Benz customer centre. If you wish, relevant vehicle and position-related data are transmitted at the same time, thereby allowing the centre to react quickly and provide rapid on-site assistance. Also standard with your new car at no extra charge is the Mercedes-Benz Mobilo³ mobility package. Whether you have lost your key, had a breakdown which cannot be repaired immediately or suffered damage to the vehicle due to an accident or vandalism, Mobilo helps you reach your destination – anywhere in Europe. Whatever is holding you up, you will soon be able to resume your journey.

Mercedes-Benz Museum. Discover what has been moving the world for over 125 years, and embark on a fascinating journey through automotive history in the Mercedes-Benz Museum. More than 1500 exhibits covering an area of 16,500 square metres chart the unique heritage and innovative flair of the inventor of the motor car. From the very

first model through to the very latest, you will find one legendary car after another awaiting you. The museum is a spectacular sight in its own right too, thanks to an architecture that breaks away from traditional concepts and creates an unprecedented sense of space. Welcome to the Mercedes-Benz Museum – a world of innovation. www.mercedes-benz-classic.com/museum

Test drive. The unique feeling of driving a Mercedes cannot be put into words – you have to experience it for yourself. Take a test drive and find out first hand how it feels to drive your dream car. Please contact your nearest Mercedes-Benz dealer for details.



¹ Alternative: +49 69 95 30 72 77 ² Requires a factory-fitted radio, connected to an operational mobile phone. The only charge incurred is the cost of the mobile phone call to the landline network ³ Once the mobility guarantee has expired (four years), Mobilo can be extended to provide cover in the event of breakdown and insurance claims one year at a time for a maximum of 30 years, provided that regular maintenance is carried out by your Mercedes-Benz service partner

Interactive Owner's Manual and Mercedes-Benz Guides.

The website also offers an interactive tour, enabling you to acquaint yourself with your dream car. You can view key functions in detail, gain an insight into the car's inner workings or look at the benefits of each model. For further details, go to www.mercedes-benz.de/owners-manual. The "Mercedes-Benz Guides" app lets you explore the highlights of the individual models both online and offline. The app is available free of charge from the Apple® iTunes® Store (iOS) as well as the Google Play store (Android).

Mobile internet. The entire world of Mercedes-Benz can be accessed at any time with your web-capable mobile device - including specially adapted content for both smartphones and tablets. As well as an overview of all the passenger car models, there are insights into the entire brand world along with a wealth of entertainment offers and direct links to our range of services at www.mercedes-benz.com

Mercedes-Benz service contracts. Vehicle-specific service contracts allow you to arrange individual cover for your Mercedes: for a small monthly premium, the Excellent service contract covers all service jobs including maintenance, wear and repairs for up to five years. Simply present your service card and you will be safe from any unwelcome financial surprises - and you can relax in the knowledge that your Mercedes will stay on top form for a long time to come. The Advance service contract provides a warranty extension, so you will be protected against unexpected repair costs even after the manufacturer's warranty or the Excellent service contract has expired - for up to ten years.



Accident repairs. Should the worst happen and you find yourself in need of repairs, with the Mercedes-Benz accident repair service you will receive the best possible assistance for your vehicle and ensure that its high-quality safety features are properly maintained. Whether you need paint, body or glass repair work carried out, the highly trained specialists at your Mercedes-Benz service partner will repair your Mercedes-Benz and get you quickly back on the road again. Further information is available from your authorised Mercedes-Benz dealer.



Shooting Brake dimensions

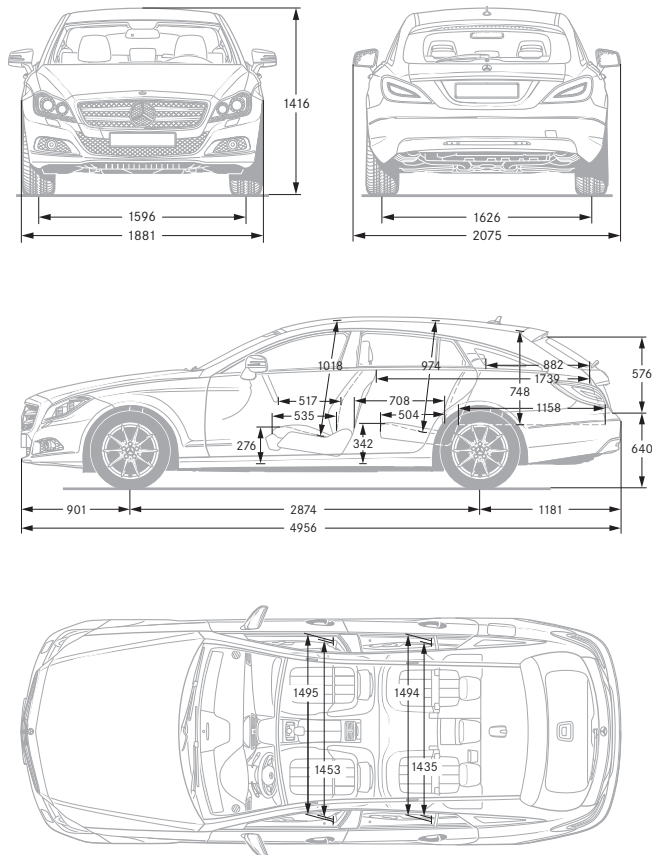

Coupé dimensions

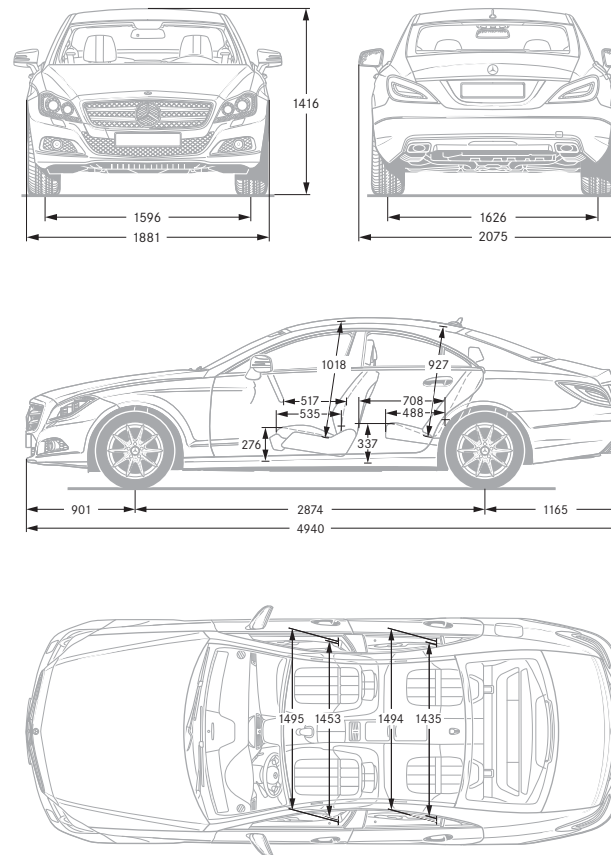

Paintwork

The paint system developed by Mercedes-Benz includes an exceptionally resistant clearcoat and is a key factor behind the car's excellent value retention.

Non-metallic paint

040 black

Metallic paints¹

197 obsidian black
 497 cuprite brown
 541 thulite red
 755 tenorite grey
 775 iridium silver
 792 palladium silver
 794 pearl beige
 795 manganite grey SHAPE²
 799 diamond white BRIGHT
 890 cavansite blue
 963 indium grey

Special paints¹

044 designo magno allanite grey²
 047 designo alubeam titanium^{3, 4}
 049 designo magno cashmere white²

Technical data

No. of cylinders/arrangement
Total displacement (cc)
Rated output ¹ in kW (hp) at rpm
Rated torque ¹ in Nm at rpm
Acceleration from 0 to 100 km/h in s [Shooting Brake]
Top speed, approx. in km/h [Shooting Brake]
Tyre size – front axle, rear axle
Fuel
Fuel consumption ³ in l/100 km
Urban [Shooting Brake]
Extra-urban [Shooting Brake]
Combined [Shooting Brake]
CO ₂ emissions ³ in g/km combined [Shooting Brake]
Emission class
Tank capacity in l/of which reserve approx.
Boot capacity in l [Shooting Brake]
Turning circle diameter in m
Kerb weight ⁴ in kg [Shooting Brake]
Perm. GVW in kg [Shooting Brake]

Diesel engines

CLS 250 CDI BlueEFFICIENCY	CLS 350 CDI BlueEFFICIENCY	CLS 350 CDI 4MATIC BlueEFFICIENCY
4/in-line	6/V	6/V
2143	2987	2987
150 (204)/3800	195 (265)/3800	195 (265)/3800
500/1600–1800	620/1600–2400	620/1600–2400
7.5 [7.8]	6.2 [6.6]	6.4 [6.7]
242 [235]	250 ²	250 ²
245/45 R 17	245/45 R 17	245/45 R 17
Diesel fuel	Diesel fuel	Diesel fuel
6.5–6.4 [6.4–6.3]	7.8 [7.5–7.3]	8.8 [8.0–7.9]
4.5–4.4 [4.8–4.7]	5.1–5.0 [5.4–5.3]	5.8–5.6 [6.0–5.9]
5.3–5.1 [5.4–5.3]	6.1–6.0 [6.1–6.0]	6.9–6.7 [6.7–6.6]
138–134 [143–139]	160–159 [162–159]	181–177 [176–174]
Euro 5	Euro 5	Euro 5
59/8	80/9	80/9
520 [590]	520 [590]	520 [590]
11.27	11.27	11.27
1785 [1865]	1815 [1910]	1875 [1970]
2270 [2390]	2300 [2435]	2360 [2495]

¹ Figures in accordance with Directive 80/1269/EEC in the currently applicable version ² Electronically governed ³ The figures shown were obtained in accordance with the prescribed measuring process (Directive [EC] 715/2007 in the currently applicable version).
⁴ The figures are not based on an individual model and do not constitute part of the product offer; they are provided solely for purposes of comparison between different vehicle models

Petrol engines

CLS 350 BlueEFFICIENCY	CLS 500 BlueEFFICIENCY	CLS 500 4MATIC BlueEFFICIENCY	CLS 63 AMG	CLS 63 AMG Performance package ⁵
6/V	8/V	8/V	8/V	8/V
3498	4663	4663	5461	5461
225 (306)/6500	300 (408)/5000-5750	300 (408)/5000-5750	386 (525)/5250-5750	410 (557)/5250-5750
370/3500-5250	600/1600-4750	600/1600-4750	700/1700-5000	800/2000-4500
6.1 [6.7]	5.2 [5.3]	5.2 [5.3]	4.4	4.3
250 ²	250 ²	250 ²	250 ²	250 ²
245/45 R 17	255/40 R 18	255/40 R 18	255/35 ZR 19, 285/30 ZR 19	255/35 ZR 19, 285/30 ZR 19
Premium petrol	Premium petrol	Premium petrol	Super Plus petrol	Super Plus petrol
9.5-9.1 [9.8-9.7]	12.5 [12.8-12.7]	13.5-13.4 [13.4-13.3]	13.9 [14.0]	13.9
5.6-5.4 [5.9-5.8]	6.9 [7.2-7.1]	7.5-7.4 [7.9-7.8]	7.6 [7.8]	7.6
7.0-6.8 [7.4-7.3]	9.0 [9.3-9.2]	9.7-9.6 [9.9-9.8]	9.9 [10.1]	9.9
164-159 [172-169]	209 [216-214]	226-224 [231-229]	231 [235]	231
Euro 5	Euro 5	Euro 5	Euro 5	Euro 5
80/9	80/9	80/9	66/14	66/14
520 [590]	520 [590]	520 [590]	520 [590]	520
11.27	11.27	11.27	11.30	11.30
1735 [1830]	1890 [1.955]	1940 [2005]	1870 [1955]	1870
2220 [2355]	2375 [2480]	2425 [2530]	2415 [2530]	2415

⁴ Figures according to Directive 92/21/EC, version 95/48/EC (kerb weight with fuel tank 90% full, driver, 68 kg, and luggage, 7 kg) for standard-specification vehicles. Optional extras and accessories will generally increase this figure and reduce the payload capacity accordingly. Figures apply to engines with standard-fit 7G-TRONIC PLUS automatic transmission or AMG SPEEDSHIFT MCT 7-speed sports transmission (CLS 63 AMG) ⁵ CLS 63 AMG Coupé only

Non-metallic paint



040

Metallic paints¹

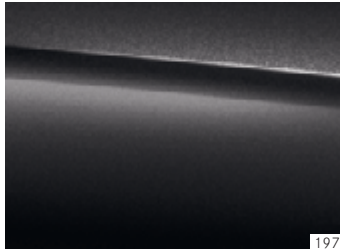

197

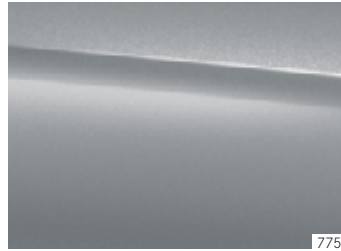

775



799

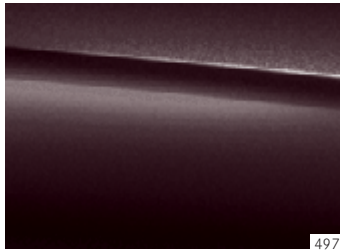

497

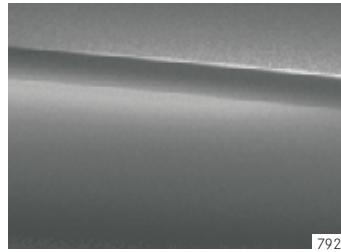

792

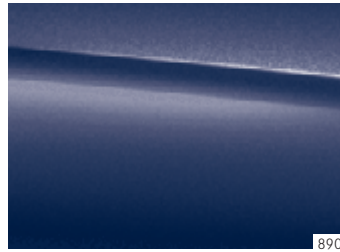

890

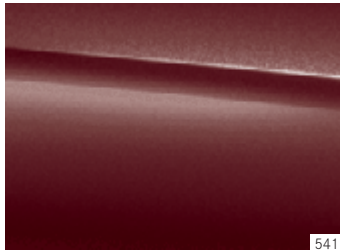

541

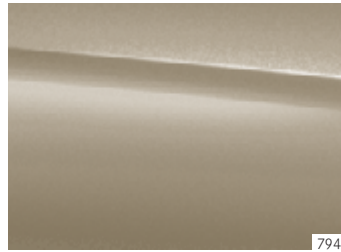

794

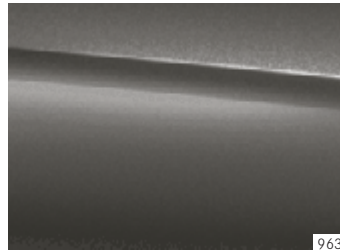

963

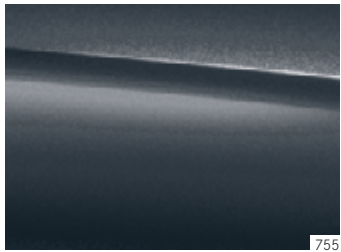

755

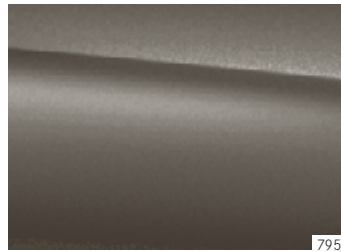

795

Special paints¹

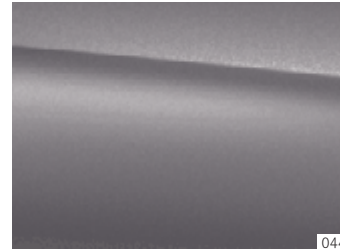

044

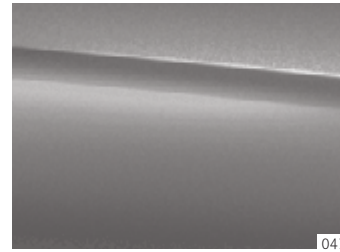

047



049

Take-back of end-of-life vehicles. You can return your CLS-Class to us for environment-friendly disposal in accordance with the European Union (EU) End-Of-Life Vehicle Directive. But that day lies a long way off.

A network of vehicle take-back depots and dismantlers has been established to make it as easy as possible for you to return your vehicle. You can leave it at any of these points free of charge and, by doing so, make an important contribution to completing the recycling process and conserving resources.

For further information about the recycling and disposal of end-of-life vehicles, and the take-back conditions, please visit the national Mercedes-Benz website.

Please note: changes may have been made to the product since this brochure went to press (14.09.2012). The manufacturer reserves the right to make changes to the design, form, colour and specification during the delivery period, provided these changes, while taking into account the interests of the vendor, can be deemed reasonable with respect to the purchaser. Where the vendor or the manufacturer uses symbols or numbers to describe an order or the subject of an order, no rights may be derived solely from these. The illustrations may show accessories and items of optional equipment which are not part of standard specification. Colours may differ slightly from those shown in the brochure, owing to the limitations of the printing process. This brochure is distributed internationally. It provides a general indication of the range of models, features, optional extras and colours available in various countries. Some of the models, features, optional extras and colours shown may not be available in your country or may only be available in a different specification. Additionally some models, features, optional extras and colours may only be available in combination with others. For current and more specific information in relation to the range of models, features, optional extras and colours available in your country, and their pricing, you should contact your nearest authorised Mercedes-Benz Passenger Car Dealer.

www.mercedes-benz.com