

This Brochure is prepared by Daimler AG and it predominantly reflects the capabilities and performance of vehicles sold in Europe. Some characteristics, capabilities, performance features and optional extras (e.g. towing systems) may not be available or may not apply in Australia or under Australian conditions. The information in this Brochure is therefore indicative, illustrative and provided only for guidance and should not be relied on. To obtain current and accurate information on a vehicle and any options applicable to Australia, contact your local authorised Mercedes-Benz dealer.



Mercedes-Benz

The SL-Class



Mercedes-Benz

”. It was the legendary 300 SL, the model that established a unique tradition of sports
enviable position: so much so, that the breathtaking feeling of sitting at the wheel of a
And the extreme roadholding is like nothing you have ever experienced. But one thing
an the SL. The latest model continues this tradition, not least with its new BlueDIRECT
the filling station. The new SL embodies a design philosophy which rejects the everyo
onance cavity – an innovative and acoustically impressive design solution. Although a
ery driving assistance system currently available, makes it one of the world’s safest ca
aking acceleration. Its newly developed 4-piston fixed-calliper front brakes have real b
The supremely confident cornering performance of the new SL will have the adrenalin
tional MAGIC SKY CONTROL folds away beneath the taut lines of the rear section in a
good taste, too. **Athlete, Aesthete.** Good, better, best. According to the grammar books,
dynamism and maximum efficiency. Not to mention the world’s torquiest V8 twin tur



Opposites attract – and nowhere are they more attractive than in the new SL, whose ability to reconcile extremes is unrivalled. It embodies both a legendary sports car tradition and trend-setting innovations. It is a car that looks to the future while recalling the past. This is true not only of its aesthetically appealing design with its elegant acknowledgements of its proud history, but also of its exemplary safety concept featuring assistance and protection systems. The highly advanced chassis systems allow the handling to be adjusted between dynamism and comfort, as required by the driver. Efficient engines, a luxurious interior and

perfection down to the smallest detail underline the exceptional status of this dream sports car. Thanks to the new, optional panoramic roof, the occupants can enjoy the visual dimension of open-top motoring even when the roof is closed. And with Front Bass, the new SL boasts a world first which redefines high-end acoustics. In this way, sportiness and comfort combine to create a uniquely refined driving experience. The new SL is simply both: an athlete and an aesthete.

At a glance | from page 4 Insight | from page 26

Featured models:
SL 500 cerussite metallic SHAPE cover and from page 2 AMG Sports package AMG 5-spoke light-alloy wheels, Exclusive nappa leather in black, light longitudinal-grain aluminium trim
SL 350 designo zircon red metallic from page 12 10-spoke light-alloy wheels, nappa leather in porcelain, satin-finish light brown poplar trim
SL 63 AMG designo allanite grey magno from page 20 AMG 10-spoke light-alloy wheels, Exclusive nappa leather in black, light longitudinal-grain aluminium trim

The illustrations may include accessories and optional extras which do not form part of the standard specification

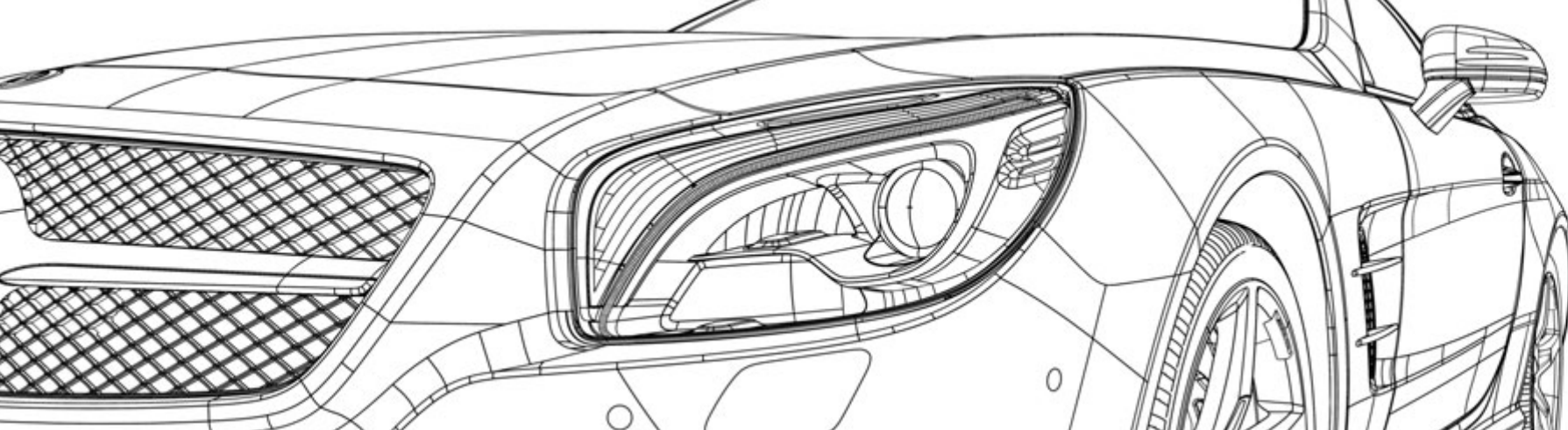

Motoring pleasure in top form: BlueEFFICIENCY, petrol engines, transmission and chassis

Drive system & chassis | from page 32

Maximum safety: integral safety concept technologies for the “Safe driving”, “In the event of danger”, “In an accident” and “After an accident” phases.

Safety | from page 38

Comfortable driving in the SL: all about multimedia and assistance systems, open-air comfort, roof variants and climate control, plus seats

Comfort | from page 40

Powerful AMG models: all about the SL 63 AMG and SL 65 AMG as well as AMG Performance Studio

AMG | from page 52

A roadster with personality: standard equipment and optional extras, AMG Sports package, designo, upholstery and trim, wheels and genuine accessories

Equipment and appointments | from page 62

Star service: MercedesCard, Mercedes-Benz Financial Services, Mercedes-Benz mobility, Mercedes-Benz Museum, test drive, Interactive Owner’s Manual and Mercedes-Benz Guides, mobile internet, service contracts, accident repairs

Services | from page 80

SL in detail: dimensions, technical data and paintwork

Facts & colours | from page 82





Forged in a fire that never goes out: passion

It was over fifty years ago that an automobile was created that was to go on to receive the title “Sports Car of the Century”. It was the legendary 300 SL, the model that established a unique tradition of sports cars. Today, a new SL era is beginning as the latest generation brings a new dimension of outstanding design and engineering excellence to the legacy of its distinguished forbear. The legend lives on.

The fine art of flying without taking off

SL drivers are in an enviable position: so much so, that the breathtaking feeling of sitting at the wheel of an SL is impossible to express in mere words. So let's look at the underlying technology: the body is a triumph of aluminium engineering, the chassis a gamechanger which reconciles comfort and dynamism to perfection. And the extreme roadholding is like nothing you have ever experienced. But one thing remains resolutely familiar: the outstanding quality of Mercedes-Benz technology. → Page 37







Proves that you have no need to prove anything any more

There is no greater challenge than that of repeatedly surpassing oneself. But few have risen to it more successfully over the years than the SL. The latest model continues this tradition, not least with its new BlueDIRECT engines which are more powerful – and economical – than ever, proving that it is possible to deliver higher performance and efficiency with less displacement. The SL keeps on surpassing itself. Even at the filling station. → Page 32–35





A high-angle, black and white photograph of the interior of a Mercedes-Benz SL. The focus is on the front passenger seat, which is upholstered in dark leather with perforated sections on the seat cushion and backrest. The seat is positioned next to a side panel that features a large, rectangular speaker grille with a circular tweeter or driver unit. The car's door panel is visible on the left, showing a silver door handle and control buttons. The background shows the car's exterior and a concrete pillar, suggesting the car is parked in a garage or showroom.

Nothing less than luxury

The new SL embodies a design philosophy which rejects the everyday in favour of the exclusive. There are no bass loudspeakers to be found in the doors, for example. Instead, the sound is emitted from the side members of the front section of the car. The vehicle body itself becomes a resonance cavity – an innovative and acoustically impressive design solution. → Page 40, 41





Wide awake, yet still a dream

Although an SL is a dream to drive and extremely comfortable, it is always alert and designed to ensure that you are, too. A range of intelligently coordinated safety components, which can be extended optionally with practically every driving assistance system currently available, makes it one of the world's safest cars. Which is, after all, what one would expect from the SL, the Mercedes among roadsters.

→ Page 38, 39, 42, 43





On course for euphoria

Open up the vario-roof, open up the throttle and feel the endorphins kick in. The supremely confident cornering performance of the new SL will have the adrenaline surging through your veins. Even when it is stationary, its looks alone have the power to move you.

Mastered. Not tamed

When you're always out in front, it's important to look good from the rear, too. But the new SL doesn't just impress with breathtaking acceleration. Its newly developed 4-piston fixed-calliper front brakes have real bite which can deliver equally reassuring deceleration. Which is good to know, if your enthusiasm at the wheel should ever get the better of you.





The image shows the interior of a Mercedes-Benz SL, focusing on the front and rear seats upholstered in light-colored leather with dark stitching. The car is parked on a rooftop or elevated platform, offering a panoramic view of a city skyline under a cloudy sky. The interior features a combination of light and dark leather, with a dark leather center console and door panels. The text is overlaid on the lower-left portion of the image.

One of the most impressive features of the new SL is usually out of sight when the sun is shining. The light vario-roof with optional MAGIC SKY CONTROL folds away beneath the taut lines of the rear section in a matter of seconds. Once stowed, it reveals a cockpit that complements the stylish exterior to perfection. As an option, it can be enhanced with exclusive, elegant leather upholstery which reflects not just the sun, but your good taste, too. → Page 44-47







The best. And then some

Good, better, best. According to the grammar books, that's as far as it goes. We beg to differ. Take the new SL 63 AMG, for example. First among equals, it features a unique combination of outstanding dynamism and maximum efficiency. Not to mention the world's torquiest V8 twin turbocharged engine to be found in a series-production vehicle. → Page 52-55





The sky's the limit.
Even with the roof closed

Car enthusiasts the world over are united by the pursuit of certain eternal questions. How can the best be made even better? When can a car's performance be judged to be perfect? Who pushes the limits to the limit? There can only be one answer: the new SL 63 AMG.

A silver Jaguar driving through a tunnel, with motion blur on the road and lights. The car is on the right side of the frame, moving towards the left. The tunnel has a series of lights on the ceiling and walls, creating a sense of depth and speed. The car's wheels and the road surface are blurred, emphasizing its rapid movement. The overall atmosphere is dynamic and futuristic.

Who says “transport of delight”
is just a figure of speech?



How Rudolf Uhlenhaut honed a legend to perfection





So far, the factory archives in Stuttgart have failed to yield any evidence that the “L” in the model designation actually does stand for “light”. But there are good reasons for believing this to be the case. When the head of vehicle testing, Rudolf Uhlenhaut, and his team rolled up their sleeves at the beginning of the nineteen-fifties, the incessant sound of drilling, grinding and filing that issued from their small workshop testified to the pursuit of one objective in particular: the world’s first 300 SL was to be a racing car whose lightness would put it beyond reach of the competition. Uhlenhaut began by developing an intricate tubular steel framework, the legendary space frame. Rather than cladding the car in sheet steel,

he used aluminium and inclined the engine to keep the bonnet line low. He even renounced the classic radiator grille with a free-standing Mercedes star in order to create a flat, racing-car-style front.

In contrast to all these reductive measures, the cockpit was surprisingly comfortable. “The driver”, Uhlenhaut said, “should derive a sense of well-being from his workplace.” Of course, his words also apply to the new SL, whose links to the tradition established by its forbear are not restricted to its lightweight aluminium body.

dent. Metallic paints. Sound system. Petrol engines. AMG. Acceleration. Design. Emiss
. LED daytime running lamps. Engines. Paintwork. Total displacement. Facts and colour
ment and appointments. Test drive. Light-alloy wheels. Memory package. Transmissio
es. Upholstery and trim. Assistance systems. BlueEFFICIENCY. In an accident. Metalli
nsion. Optional extras. Fuel consumption. Interior. Airbags. In the event of danger. LED
ent. Light. Multimedia systems. Drive system. Genuine accessories. Test drive. Equipm
ther. BlueEFFICIENCY. Comfort. Cylinders. Technical data. Interior. Services. Safety. A
s. Safe driving. Light-alloy wheels. Top speed. Optional extras. Chassis & suspension. F
ment. Climate control. Seats. Dimensions. Standard equipment. Light. Multimedia syst
heels. Interior. Cylinders. Technical data. Dimensions. Services. BlueEFFICIENCY. Ass
s. Safe driving. **The facts.** Cylinders. Technical data. Dimensions. Services. BlueEFFICI
on class. Safe driving. Light-alloy wheels. Top speed. Chassis & suspension. Optional ex

32 **BlueEFFICIENCY**33 **SL-Class BlueEFFICIENCY**34 **Petrol engines**

6-cylinder petrol engine

8-cylinder petrol engine

36 **Transmission**

7G-TRONIC PLUS

37 **Chassis & suspension**

Active Body Control ABC

Suspension with Adaptive Damping

System ADS

Direct-Steer system with EPS

Torque Vectoring Brakes

38 **Integral safety concept**

ATTENTION ASSIST

Intelligent Light System

Adaptive wiper system

MAGIC VISION CONTROL

Driving Assistance package Plus

PRE-SAFE® Brake and BAS PLUS

PRE-SAFE® system

Restraint systems

Mercedes-Benz emergency call system

Measures after an accident

40 **Multimedia systems**

Harman Kardon® Logic 7® surround

sound system

Bang & Olufsen BeoSound AMG

COMAND Online

42 **Assistance systems**

Speed Limit Assist

Active Parking Assist, incl. PARKTRONIC

44 **Open-air comfort**

AIRSCARF

Electric draught-stop

Sun-reflecting leather

46 **Roof and space**

Panoramic vario-roof with MAGIC SKY

CONTROL

Vario-roof

Panoramic vario-roof

EASY-PACK function

KEYLESS-GO Convenience package

48 **Climate control and light**

THERMOTRONIC

Ambient lighting

50 **Seats**52 **SL 63 AMG**54 **SL 63 AMG technology**56 **SL 65 AMG**58 **SL 65 AMG technology**60 **AMG Performance Studio**

62 Standard equipment**63 Optional extras****64 AMG Sports package****68 designo****70 Upholstery and trim****76 Wheels**

Standard wheels

Optional wheels

AMG wheels

Genuine-accessory wheels

78 Genuine accessories**80 Services**

MercedesCard

Mercedes-Benz Financial Services

Mercedes-Benz mobility

Mercedes-Benz Museum

Test drive

Interactive Owner's Manual and

Mercedes-Benz Guides

Mobile internet

Service contracts

Accident repairs

82 Dimensions**82 | 85 Paintwork****83 Technical data**

BlueEFFICIENCY – fast forward to tomorrow

Mercedes-Benz is quicker at getting future technologies to where they matter most: on the road. With the exception of the G-Class and R-Class, all of our 4, 6 and 8-cylinder models now include BlueEFFICIENCY measures that help to reduce your impact on the environment significantly. Our BlueEFFICIENCY concept comprises innovations for efficient mobility as well as optimised processes all the way along the value chain.

The BlueEFFICIENCY measures – the Mercedes-Benz efficiency package. A comprehensive set of vehicle enhancements saves fuel and eases the burden on the environment. Each model combines the most efficient engine with the very latest aerodynamic and energy-management measures, including the ECO start/stop function available for most models. The BlueDIRECT V6 and V8 petrol engines featured in many model series deliver more power while reducing consumption by up to 25%. The new BlueEFFICIENCY Edition badge is reserved for the most economical models in selected ranges. These vehicles employ special measures to save weight, reduce air resistance or optimise the drivetrain and thereby achieve even lower fuel consumption and CO₂ figures.

BlueTEC – the clean diesel. A modular emission-control system makes BlueTEC an exceptionally clean diesel technology, as it not only removes up to 95% of the particulate matter from the exhaust gases but also reduces nitrogen oxides by up to 90%. What remains is mainly water and nitrogen.

HYBRID – combustion engine and electric motor intelligently combined. A well-coordinated team can achieve more, as hybrid technology certainly proves. The electric motor supports the engine during the journey – e.g. with a boost effect for more powerful acceleration – or it acts as a generator, recuperating energy during braking in order to charge the battery (regenerative braking). The latest-generation hybrid drive system is capable of all-electric operation for up to one kilometre at a maximum speed of 35 km/h and also allows efficient, emission-free coasting at speeds below 160 km/h by shutting off the engine on the overrun and disengaging the drive system. And for the first time, these benefits are also available in a premium-class diesel model – without any loss of spaciousness. The E 300 BlueTEC HYBRID¹ is also the world's most economical luxury-segment model.

Innovative drive systems that break new ground.

In mid-2013, our electric drive technology will be moving into the fast lane with the arrival of the SLS AMG Coupé Electric Drive², which takes electric driving into a whole new dimension. This super sports car equipped with four synchronous electric motors is our second production-ready electric car and delivers superb performance figures: 551 kW and 1000 Nm make it the most powerful AMG high-performance model ever, yet it produces no local emissions. Another innovative alternative, the hydrogen drive, has also taken to the road at Mercedes-Benz with a small-scale series of B-Class models that use a fuel cell to generate power for the electric motor. Finally, the F 125! represents the future of zero-emission motoring in the luxury class.

But that's not all: under the banner "Design for Environment", we look at a vehicle's entire lifecycle and work hard to preserve the environment, all the way from the planning stage through to recycling. What's more, we are involved in the development of alternative fuels and carry out research in the field of bionics.

Further information about our comprehensive measures can be found at: www.mercedes-benz.com/blueefficiency

¹ E-Class E 300 BlueTEC HYBRID Saloon: the vehicle complies with the Euro 5 emissions standard. Fuel consumption – urban: 4.3–4.2 l/100 km, extra-urban: 4.3–4.2 l/100 km, combined: 4.3–4.2 l/100 km; CO₂ emissions combined: 112–109 g/km

² SLS AMG Coupé Electric Drive – CO₂ emissions combined in g/km: 0; electrical consumption combined in kWh/100 km: 26.8 The figures shown were obtained in accordance with the prescribed measuring process (Directive [EC] 715/2007 in the currently applicable version).
The figures are not based on an individual model and do not constitute part of the product offer; they are provided solely for purposes of comparison between different vehicle models

SL-Class BlueEFFICIENCY

Always a vehicle that sets benchmarks, the SL also lives up to its high technological standards where the reduction of both fuel consumption and emissions is concerned



Environmental responsibility is an extremely important factor in the development of a vehicle. It is only logical, therefore, that the new SL is characterised not only by significantly greater agility and pulling power than its predecessor, but by considerably lower fuel consumption, too. This is made possible by efficient BlueDIRECT engines, offering higher output while reducing fuel consumption by up to approximately 29%, as well as a number of other measures.

- 1 Lightweight design through aluminium body and intelligent weight optimisation
- 2 Fuel consumption reduced by up to approx. 29% by BlueDIRECT engine technology (SL 350 BlueEFFICIENCY, SL 500 BlueEFFICIENCY)
- 3 Optimised aerodynamics (exterior mirrors, underbody panelling)
- 4 Tyres with optimised rolling resistance
- 5 Refrigerant compressor only activated when actually needed
- 6 Adjustable radiator shutter
- 7 ECO start/stop function
- 8 Current fuel consumption indicator
- 9 Intelligent alternator management (alternator switched off when throttle open)
- 10 7G-TRONIC PLUS automatic transmission with dynamic response
- 11 Ancillaries with energy-saving control and on-demand activity (e.g. fuel and oil pump)
- 12 Entire engine range complies with the Euro 5 emission class

Petrol engines

Built for top performance. The new SL Roadster offers all the exhilarating sensations of a sports car. Powerful, high-torque engines put you in touch with speed in its most authentic form in the new SL

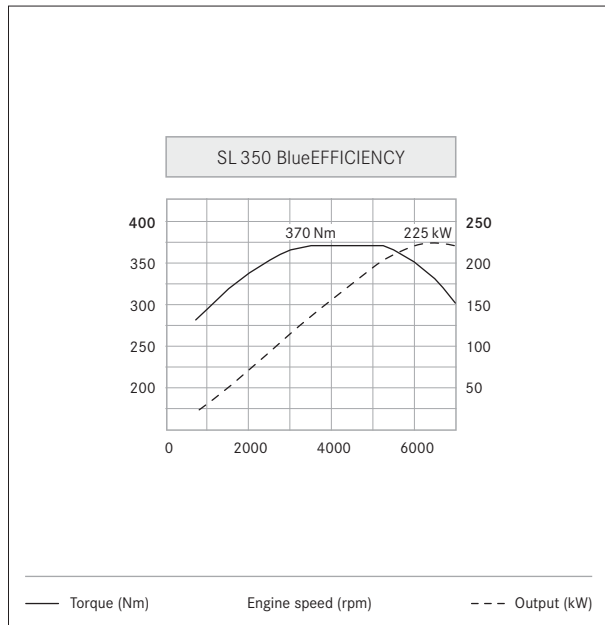

With an output of 225 kW (306 hp), the SL 350 BlueEFFICIENCY Roadster boasts dynamic performance

6-cylinder petrol engine. The innovative BlueDIRECT V6 engine in the new SL 350 BlueEFFICIENCY makes systematic use of lightweight materials. With its trend-setting technology – including spray-guided direct petrol injection with piezo injectors, four valves per cylinder as well as adjustable intake and exhaust camshafts – it is able to achieve a fuel saving of up to some 29 percent compared with the predecessor model. Its CO₂ emissions are also correspondingly lower while its performance is more dynamic. In addition to the enhanced combustion process, other factors which contribute to the reduction in fuel consumption include the standard-fit ECO start/stop function, an all-new air intake and exhaust system, controlled ancillaries and intelligent alternator management. With an output of 225 kW (306 hp), the engine offers powerful acceleration, even at low revs, and very smooth running characteristics across the entire engine speed

range. A special resonance intake manifold delivers a powerful engine note.

8-cylinder petrol engine. The BlueDIRECT 8-cylinder engine in the new SL 500 BlueEFFICIENCY ensures effortlessly superior performance in any driving situation. An array of innovative technologies makes for reduced fuel consumption and significantly higher power from a reduced displacement. The technological highlights include the systematic lightweight design, moderate downsizing to a displacement of 4.7 litres and direct injection with precise piezo injectors. Twin turbochargers with charge air cooling ensure sustained high performance and significantly increased torque. This is reflected in the performance data: the new SL 500 BlueEFFICIENCY with the BlueDIRECT engine develops an impressive output of 320 kW (435 hp) and a massive 700 Nm of torque between 1800 and

3500 rpm. Although the performance is considerably more dynamic than that of the predecessor model, the fuel consumption is down by as much as some 22 percent and the CO₂ emissions are also correspondingly lower.

Both the 6- and 8-cylinder engine are equipped as standard with the ECO start/stop function, which can help save fuel at traffic lights and in jams, thereby easing the burden on the environment. And it goes without saying that both engines comply with the Euro 5 emission class.



The new SL's petrol engines combine driving pleasure with efficiency

Transmission

Innovative transmission technology, optimally tuned in the new SL, brings the power of the responsive, high-torque engines effortlessly to the road

7G-TRONIC PLUS (standard). Optimised for lower fuel consumption and increased efficiency, the 7G-TRONIC PLUS transmission with steering-wheel shift paddles takes care of changing gear in the new SL. The 7G-TRONIC PLUS features a new-generation torque converter which responds more dynamically, operates even more quietly and delivers a significant reduction in fuel consumption. The latter is also a result of combining the transmission with the standard-fit ECO start/stop function, which switches the engine

off temporarily when waiting at traffic lights or in a traffic jam. The seven forward gears of the 7G-TRONIC PLUS transmission allow a wider spread between the lowest and highest ratio yet also make for smaller shifts in engine speed between one gear and the next. This ensures that the engine always operates at the optimum speed, reduces fuel consumption and renders gear changes almost imperceptible. At the same time, it makes the driving experience even more enjoyable: the vehicle's acceleration is improved

and it develops greater pulling power. And for quick bursts of speed, multiple downshifting allows the 7G-TRONIC PLUS to skip gears when changing down.

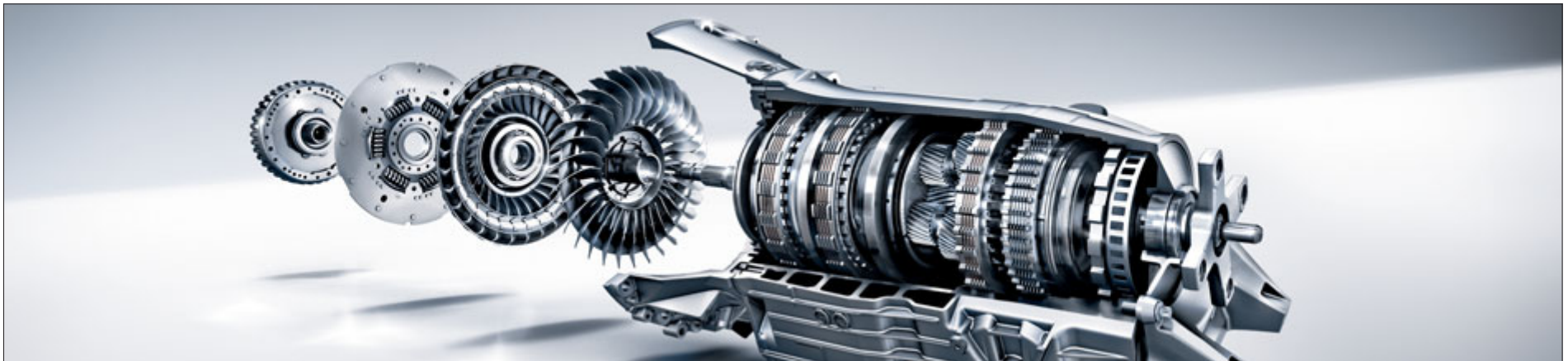

The 7G-TRONIC PLUS: one of over 18 million automatic transmissions produced in a period spanning more than 50 years

Chassis & suspension

The new SL Roadster is as at home cruising comfortably along country roads as it is tackling hairpin bends at a sporty tempo. This is possible thanks to the different suspension systems and settings available

Active Body Control ABC (option). This system offers maximum ride comfort and enhanced driving dynamics through a combination of active suspension and passive damping. The movements of the vehicle body when moving off and braking are also significantly reduced, as is body roll when cornering. A comfort-oriented or sporty suspension setup can be selected at the touch of a button and the currently selected suspension mode can be called up in COMAND.

Suspension with Adaptive Damping System ADS (standard). The electronically regulated damping system adjusts its characteristics continuously and steplessly, the damping force being optimally adapted to each individual wheel in accordance with the current handling situation and road conditions. This results in greater handling stability in all speed ranges. The dampers can be set to sport mode at the push of a button.

Direct-Steer system with EPS (standard). This system makes steering easier and leads to improved cornering. Fewer steering movements are required when manoeuvring and the electromechanically assisted steering gear (EPS) can save fuel.

Torque Vectoring Brakes (standard). When cornering at speed, the rear wheel on the inside of the bend is braked slightly to optimise distribution of the drive forces to the rear wheels for even sharper agility.



The standard suspension with Adaptive Damping System ADS facilitates the ideal blend of sportiness and comfort

Integral safety concept

The vision of accident-free driving impels us. With our integral safety concept we are coming closer to achieving this goal – this is a holistic approach which can increase safety in every situation

As the inventor of the motor car, we feel we have a special responsibility when it comes to road safety. That's why we were the first car manufacturer to develop an integral safety concept which seamlessly links active and passive safety measures to provide comprehensive protection. The all-encompassing approach is divided into four phases and provides safety solutions for any situation. It includes systems for safe driving, which help prevent danger thanks to their ability to warn and assist the driver in plenty of time. Our unique PRE-SAFE® system comes into play when danger is detected, activating anticipatory measures to protect the car's occupants. If, despite all of the preventive measures, a collision is unavoidable, further technologies can provide protection on demand. We've even thought about the time immediately after an accident and developed solutions to prevent a worsening of the situation and facilitate rapid assistance.

The following pages show some of the technologies used in the "Safe driving", "In the event of danger", "In an accident" and "After an accident" phases.

Safe driving: ATTENTION ASSIST (standard). This drowsiness detection system is especially useful on long trips. At speeds of between 80 and 180 km/h, ATTENTION ASSIST can warn the driver as soon as it identifies typical signs of drowsiness or inattention. Several sensors analyse the driver's behaviour and can detect any changes compared with the driver profile individually determined previously.

Safe driving: Intelligent Light System (standard). The system has five settings: the country mode illuminates the edge of the road, the motorway mode the entire width of the road. The enhanced fog light function improves visibility in bad weather, while the active light function and the cornering light function follow the driver's steering angle. Perceptual safety is also enhanced by Adaptive Highbeam Assist. This constantly adjusts the low-beam headlamp range to suit the prevailing traffic conditions. Main beam is activated if no road users are detected. The headlamps can be dimmed automatically again as soon as an oncoming vehicle with its lights on is detected.

Safe driving: MAGIC VISION CONTROL adaptive wiper system (standard). This system delivers the windscreen washer fluid through the wiper blade straight to the windscreen. This improves the driver's view when using the windscreen washer, consumption of washer fluid is reduced and the risk of splashes reaching the interior of the car during open-top driving is reduced. The optional heated windscreen washer system, comprising heating for the windscreen washer reservoir, the adaptive wiper system and the windscreen washer lines, provides these elements with considerably greater protection against freezing.



The MAGIC VISION CONTROL adaptive wiper system helps enhance visibility and thus contributes to greater safety

Safe driving: Driving Assistance package Plus (option).

This package makes an active contribution to everyday safety on the road. It includes the DISTRONIC PLUS proximity control, Active Blind Spot Assist, Active Lane Keeping Assist, BAS PLUS Brake Assist and the PRE-SAFE® Brake.

In the event of danger: PRE-SAFE® Brake and BAS PLUS (both part of the optional Driving Assistance package Plus).

The PRE-SAFE® Brake initially provides the driver with visual and acoustic warnings when the risk of a collision is detected. In this phase, BAS PLUS calculates the amount of brake pressure that could avoid a collision. If the braking force applied by the driver is insufficient, the system increases the braking pressure automatically so as to make optimum use of the remaining distance available. If the driver fails to respond to the signal, PRE-SAFE® Brake intervenes with autonomous partial braking that can clearly be felt. If there is still no reaction, autonomous emergency braking can then be triggered so as to significantly reduce impact speed and accident severity.

In the event of danger: PRE-SAFE® system (standard).

This anticipatory occupant protection system is able to detect certain critical driving situations in advance and activate precautionary measures. If an imminent accident is detected, the system can close the side windows and tension the front seat belts using electric motors. Depending on the vehicle equipment, the front passenger seat can also be brought into a position which is more favourable in accident conditions.

In an accident: restraint systems (standard).

3-point seat belts, belt tensioners, belt force limiters and airbags are optimally coordinated with each other at Mercedes-Benz, so as to keep injuries to a minimum wherever possible. The two-stage airbags for the driver and front passenger help to protect the upper body and head, at the same time as stabilising the entire body. The standard headbags and sidebags, meanwhile, are able to reduce the risk of injury in a side impact. The various airbags therefore allow impact protection to be adapted to requirements. If the airbag control unit detects an accident, the seat belts are automatically tightened at lightning speed. The belt force limiter then relaxes the belt again in accordance with the

particular situation, so as not to place too much of a strain on the occupant's chest.

After an accident: Mercedes-Benz emergency call system (part of COMAND Online).

The system can send an automatic emergency call via an operational telephone connected to the vehicle as soon as the restraint system detects an accident. At the same time GPS positioning data and other information on the vehicle are transmitted to the Mercedes-Benz emergency call centre. A voice connection is then established.

Measures after an accident. In order to mitigate consequential damage and, where necessary, expedite the rescue of the occupants, Mercedes-Benz has developed further measures. These include the automatic engine cut-off, for example, or activation of the hazard warning lamps and interior emergency illumination. The central locking also opens automatically, and crash joints between the door and the wing make it easier to open the doors after an accident.

Multimedia systems

Everything revolves around maximum comfort and convenience. While the standard-fit Front Bass technology delivers breathtaking acoustic performance, the optional COMAND Online multimedia system provides entertainment and navigation

Harman Kardon® Logic 7® surround sound system (option). With its 600 watt output, Front Bass and Dolby Digital 5.1 technology, the Harman Kardon® Logic 7® surround sound system makes every journey an acoustic experience to savour. 14 high-performance loudspeakers and a MOST amplifier with Digital Sound Processing provide a three-dimensional sound impression. The automatic volume control adapts the sound in line with the car's current speed.



The Harman Kardon® Logic 7® surround sound system ensures a listening experience of the highest calibre

Bang & Olufsen BeoSound AMG (option). This high-end surround sound system with Front Bass technology, 12 high-performance loudspeakers and an output of 900 watts turns the interior of the SL into a concert hall. The tweeters with Acoustic Lens Technology create the characteristic Bang & Olufsen virtual sound platform for the vehicle occupants. A special menu allows precise control of the optimum sound field for the seats in use.



Pleasing to the eye, too: outstanding audio technology with an exclusive design

COMAND Online (standard, option for SL 350). The multimedia system boasts a high-resolution 17.8 cm colour display. The functions include a radio, speed-sensitive volume control, the MUSIC REGISTER with 10 GB hard disc and hard-disc navigation with 2D and 3D map displays. What's more, for 3 years from the initial registration, it also includes free updates for European map data. The best in entertainment comes courtesy of the DVD drive which plays CDs and MP3 files as well as video and audio DVDs. The online function facilitates access to the internet plus various mobile services from Mercedes-Benz via an internet-capable mobile phone. A USB and an Aux-in socket, a slot for SD memory cards and a Bluetooth® interface enable connections to external data carriers and a mobile phone. The system is operated via the Controller and also via the buttons on the multifunction steering wheel. The LINGUATRONIC functionality, which allows control by voice entry, extends even to searching for individual music tracks and artists.

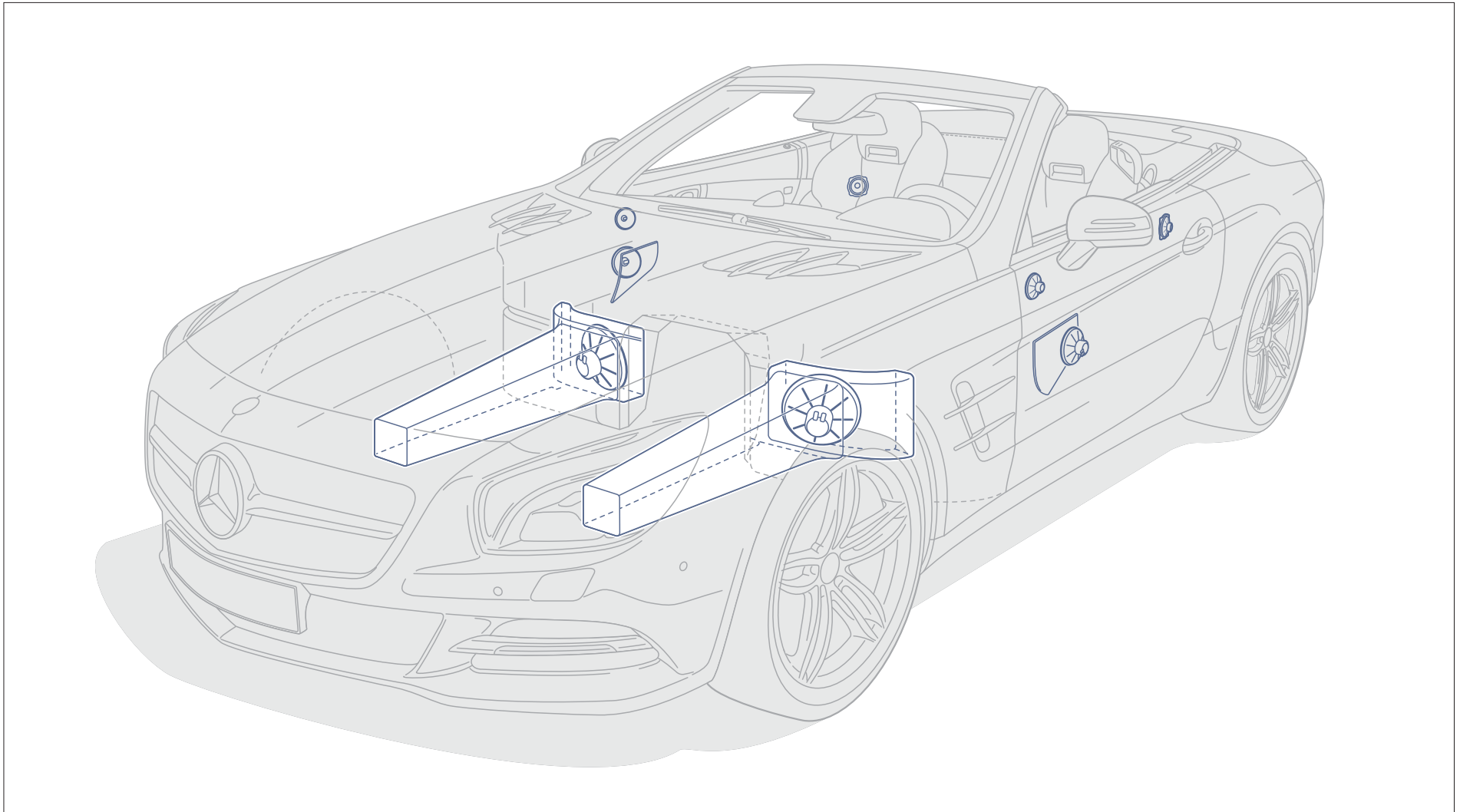

The inclusion (as standard) of Front Bass technology marks the premiere of a new dimension of sound reproduction. The resonance space of the bass loudspeakers is integrated in the bodyshell. This results in brilliant, balanced sound and improved bass performance, especially during open-top driving

Assistance systems

There are numerous assistance systems to reduce the driver's workload, both on the open road and when performing difficult manoeuvres



Speed Limit Assist (part of the optional COMAND Online). A windscreen-mounted camera that permanently scans the car's surroundings is able to recognise signed speed limits and indicate the detected maximum speed to the driver in the display. The driver can therefore check the prevailing speed limit. This added convenience is of particular benefit on routes with variable speed limits or roadworks.



The information from Speed Limit Assist is shown both in the instrument cluster and in the COMAND Online central display

Active Parking Assist, incl. PARKTRONIC (option).

Active Parking Assist begins the search for parking spaces automatically at speeds below 36 km/h, displaying a "P" and a direction arrow in the instrument cluster to indicate that it has found a suitable space. If the driver selects reverse gear, and accepts the space suggested, Active Parking Assist automatically performs the required steering movements to manoeuvre the car into the space at a speed of up to 10 km/h. All the driver has to do is operate the accelerator and brake pedals. The parking manoeuvre is



Active Parking Assist shows the driver suitable parking spaces and can carry out the parking manoeuvre automatically if required

completed in a maximum of five moves. The driver can intervene at any time to correct the parking manoeuvre. If Active Parking Assist is not used, the PARKTRONIC electronic parking aid monitors the areas to the front and rear during manoeuvring and warns the driver if a risk of collision is detected. It is active at speeds up to 16 km/h.

Open-air comfort

The new SL Roadster offers its occupants comprehensive open-air comfort of the highest standard – in every season and almost any weather

AIRSCARF (option). The neck-level heating developed by Mercedes-Benz extends the open-air season. At the touch of a button air is wrapped around the shoulders and neck of the driver and passenger like a warming scarf. In order to achieve this effect the system draws in cold air before warming it and releasing it again through discreetly positioned vents in the head restraints.



AIRSCARF delivers warm air aplenty to ensure perfect open-top motoring pleasure even in cool weather

Draught-stop, electric (option). When driving with the roof down, the electrically operated draught-stop ensures optimum protection from draughts at the touch of a button on the centre console. This triggers an electric motor which deploys a trapezoidal frame from the rear compartment trim cover. The fine-mesh textile fabric covering the frame keeps the passenger area almost entirely free of draughts.



The electric draught-stop minimises draughts in the interior of the open vehicle

Sun-reflecting leather (standard in conjunction with leather, nappa leather and Exclusive nappa leather except designo leather). As an optional extra the seats of the new SL are available with a coating which reflects heat. This prevents the seats from heating up in intense sunlight – bringing extra comfort, particularly when the vehicle is open.



The intelligent solutions deployed in the new SL Roadster ensure that neither wind nor sun nor heat can detract from the pleasure of open-top motoring

Roof and space

Comfort standards are redefined in the new SL. On the one hand, the panoramic vario-roof with MAGIC SKY CONTROL creates an impression of space and airiness even in the closed vehicle. On the other, all the roof variants offer plenty of room for luggage even when the car is open



Panoramic vario-roof with MAGIC SKY CONTROL (option). The panoramic vario-roof with MAGIC SKY CONTROL is an innovation from Mercedes-Benz. At the touch of a button the roof panel changes from dark to transparent or vice versa within seconds. This allows the driver and passenger to enjoy a view of the sky even when the roof is closed. What's more, when the glass is darkened, the heating up of the vehicle interior is considerably reduced.

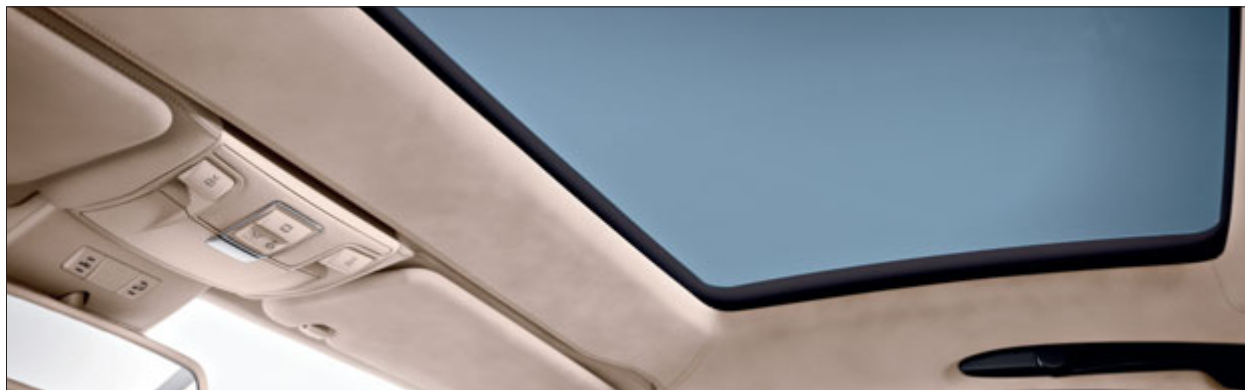

Vario-roof (standard). The fully power-retractable vehicle-colour vario-roof transforms the SL from a coupé to an open roadster at the touch of a button. It takes less than 20 seconds to open or close the roof, which also comes as standard with a radio remote control function allowing it to be operated from outside the vehicle by means of the vehicle key. And thanks to the compact design of the roof, up to 241 litres of boot space remain available when it is retracted.



The roadster's boot offers plenty of stowage space whether the roof is open or closed

Panoramic vario-roof, incl. roller blind (option). The panoramic vario-roof allows you to enjoy the views offered by a roadster with the comfort of a closed coupé. A large tinted glass panel integrated in the roof provides a clear overhead view. A manually operated roller blind offers protection from the sun when required.



Thanks to the panoramic vario-roof the occupants can enjoy an excellent view even when the roof is closed

EASY-PACK function (standard). With the roof down, the convenient EASY-PACK function improves access to items in the boot by means of a power-operated mechanism which lifts the stowed roof. When the closing button is operated, the roof is lowered to its original stowed position and the boot lid is closed.

KEYLESS-GO Convenience package with HANDS-FREE ACCESS (option). There is no need to have the key in your hand to open the car or start the engine. If you have the KEYLESS-GO key on you, all you have to do is operate the door handle. And starting the car is simply a matter of pressing the start/stop button. The HANDS-FREE ACCESS comfort function makes loading and unloading the boot easier by using a sensor to trigger automatic opening or closing of the boot lid when the driver's foot is detected beneath the rear of the vehicle.

Climate control and light

A pleasant interior climate increases motoring pleasure and driver-fitness safety. This is why the temperature in the new SL can be individually regulated while the interior can be stylishly showcased in darkness

THERMOTRONIC (standard). The luxury automatic climate control THERMOTRONIC has separate temperature controls for each side of the interior, allowing the driver and passenger to travel in comfort at the temperature of their choice. At the touch of a button the 2-zone system works fully automatically. THERMOTRONIC keeps the desired

temperature constant and also takes exterior factors such as sunlight, air quality and humidity into account via its sensors. This means that there is always a pleasant atmosphere in the new SL, boosting comfort on the one hand and the driver's concentration on the other, thus enhancing the safety of both occupants.

Ambient lighting (option). Night drives become something to relish with the pleasant, indirect ambient lighting. Luminous surfaces on the dashboard, below the door trim and in the rear compartment trim cover create a unique atmosphere. Ambient lighting is activated and deactivated with the exterior lighting. It also switches on to create a "welcome home" effect when the doors are opened. It is possible to switch between three ambient lighting colours – "SOLAR orange", "SOLAR red" and "SOLAR" – which can also be dimmed to emphasise the sporty interior design.



The standard-fit THERMOTRONIC luxury automatic climate control ensures a pleasant interior temperature



Seats

The sporty seats in the new SL meet the highest standards – and diverse requirements – in terms of ergonomic design, comfort and safety

The design of the comfortable sports seats speaks for itself. With their high side bolsters, these ergonomic seats offer optimal lateral support and enhance stability for the driver and passenger noticeably, even during dynamic driving. The exquisite leather variants which are available as an option are extremely pleasant to the touch and have the added benefit of reflecting sunlight.

The optional multicontour seats relieve the load on the spinal column and can be adjusted precisely to meet the ergonomic requirements of the driver and passenger. The pressure in the variable air cushions in the side bolsters of the seat cushions and backrests can be adjusted in line with individual requirements, as can the backrest curvature in the lumbar and shoulder regions. The active multicontour seat takes the outstanding qualities of these seats even further. It adjusts continuously to the changing lateral acceleration forces, massages the back muscles and can reduce the risk of injury in an accident.

The standard-fit seat heating brings cold seats up to a pleasantly warm temperature, before the effect of the vehicle heating can be felt, and allows independent heating of each seat to three different levels. It is also possible to adjust the heating balance between seat cushion and backrest. The optional climatized seats for the driver and passenger feature fans integrated in the upholstery. Air flows through fine perforations and quickly cools the surface of the seat to a pleasant temperature – even if the vehicle has been heated up in intense sunlight for a long time. Maximum ease of operation is assured by the standard-fit fully electric seat adjustment function with 4-way lumbar support adjustment and memory function. The electropneumatic lumbar support promotes an ergonomic posture while the memory function makes it possible to store – and recall at the touch of a button – the positions of the seat and backrest, the steering wheel and the exterior mirrors on both sides.



Standard-fit electric seat adjustment with memory function



The newly developed seats combine seating comfort with ergonomics, safety and sportiness

SL 63 AMG

The new SL 63 AMG Roadster impresses with its expressive design and innovative technology from the world of motorsport → www.mercedes-amg.com



Performance and efficiency, combined in the new SL 63 AMG Roadster

Its expressive exterior hints at the power that lies within. The new SL 63 AMG demonstrates its forward-thrusting energy through its more dynamic AMG bodystyling consisting of a front apron with side air outlets, a diffuser-style rear apron with an insert in the vehicle colour and side skirts. Silver chrome, a signature styling feature of the SL 63 AMG, is used for the lower cross strut of the front apron, the twin louvre in the AMG radiator grille and the surrounds of the special AMG LED daytime running lamps as well as the fins on the bonnet and wings. These features are complemented by the AMG spoiler lip on the boot lid and the AMG 5-twin-spoke light-alloy wheels. An AMG

sports exhaust system with two chromed twin tailpipes and “V8 BITURBO” lettering on the front wings complete the sporty look.

The interior also impresses with an exceptionally sporty ambience created by AMG sports seats in nappa leather with a special upholstery pattern, AMG carbon-fibre trim, black headlining and ambient lighting. One look at the AMG performance steering wheel trimmed in nappa leather with silver-coloured aluminium shift paddles, the AMG DRIVE UNIT with the E-SELECT selector lever and the AMG instrument cluster with AMG start-up display is enough

to create the feeling of being in the cockpit of a racing car. The integral RACETIMER can even record lap times if you ever take to the race circuit. An analogue IWC design clock is another highlight, while AMG door sill panels in brushed stainless steel with white illumination add an appropriately stylish finishing touch.



AMG sports seats in nappa leather



The AMG DRIVE UNIT in the centre console



The AMG sports exhaust system with two chromed twin tailpipes

SL 63 AMG technology

A thrilling driving experience and maximum efficiency with the AMG 5.5-litre V8 twin-turbocharged engine, the AMG SPEEDSHIFT MCT 7-speed sports transmission and the AMG sports suspension

AMG 5.5-litre V8 twin-turbocharged engine. The high-performance engine of the SL 63 AMG is built to deliver dynamic performance without neglecting economy. It offers breathtaking acceleration and outstanding performance with an engine note to set your pulse racing. The powerplant develops an impressive maximum output of 395 kW (537 hp) with maximum torque of 800 Nm. Adding the optional AMG Performance package boosts these figures to 415 kW (564 hp) and 900 Nm respectively. The

increased power and efficiency are achieved through innovative technology, such as direct petrol injection, twin turbocharging and the ECO start/stop function. The AMG high-performance compound braking system delivers excellent deceleration performance plus precision brake control with internally ventilated and perforated brake discs sized 390 x 36 mm for the front wheels and 360 x 26 mm for the rear wheels.

AMG SPEEDSHIFT MCT 7-speed sports transmission.

This unit combines the sporty, direct and agile feedback of a manual gearbox with the unrivalled comfort and convenience of an automatic. The four transmission modes – Controlled Efficiency, Sport, Sport+ and Manual as well as the RACESTART function – allow the driver to choose how dynamic the gear changes are to be.

AMG sports suspension. The AMG sports suspension is based on Active Body Control ABC and offers a choice of two settings. The setting chosen – “comfort” or “sport” – also causes a corresponding adjustment to be made to the steering characteristics of the AMG speed-sensitive sports steering. This gives the driver a sensitive and direct steering response with immediate feedback from the road. The combination of AMG sports suspension and the AMG speed-sensitive sports steering therefore ensures sporty, agile handling and compelling driving enjoyment.



Fast, comfortable gear changing with the AMG SPEEDSHIFT MCT 7-speed sports transmission



The AMG 5.5-litre V8 twin-turbocharged engine with up to 415 kW (564 hp) and 900 Nm of torque

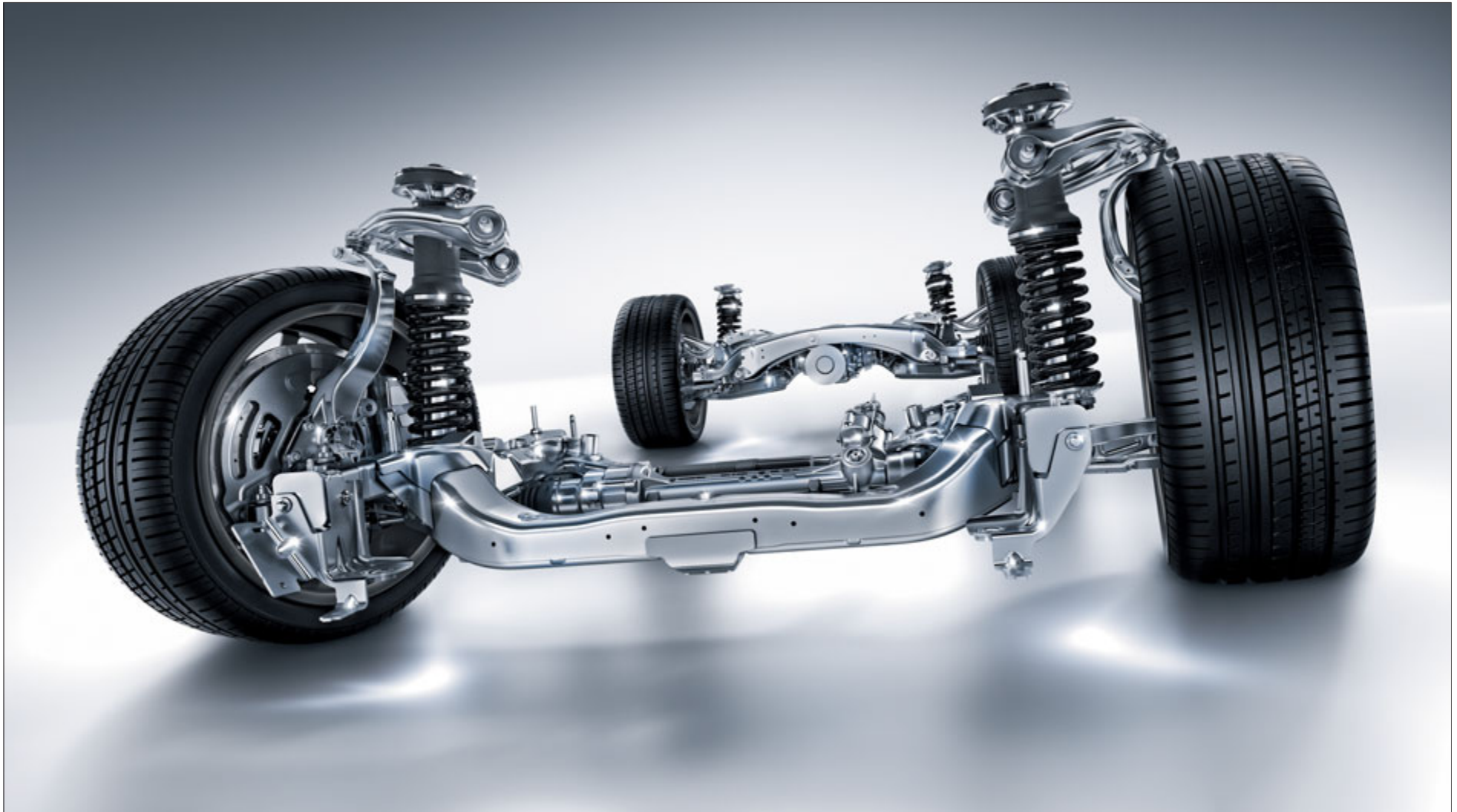

A perfect combination of driving dynamics and comfort: the AMG sports suspension based on Active Body Control ABC

SL 65 AMG

The new SL 65 AMG brings even greater luxury and exclusivity to this legendary model series



The SL 65 AMG combines phenomenal power and exclusive dynamics

The exterior of the top model differs from that of the SL 63 AMG in that the former features an AMG sports exhaust system with V12-design chromed twin tailpipes, “V12 BITURBO” lettering on the front wings and a chromed cross strut in the front apron. These elements are complemented by the high-gloss chromed finish of the twin louvre in the AMG radiator grille as well as the fins on the bonnet and wings. Special V12 AMG 5-spoke light-alloy wheels, the characteristic AMG styling and the AMG spoiler lip on the boot lid complete the picture of a consummate sports car.



AMG sports seats in Exclusive nappa leather with AMG V12 pattern

The exclusive tone is maintained inside the vehicle. Exclusive nappa leather upholstery offers an irresistible invitation to settle into the AMG sports seats whose backrests feature an embossed AMG emblem. The special V12 upholstery pattern harmonises with the V12 design of the door centre panels and the designo headlining in black leather. The equipment line-up also includes the Convenience Telephony function, the KEYLESS-GO package and Active Parking Assist as well as AIRSCARF, multicontour seats and climatized seats. The AMG performance steering wheel trimmed in nappa leather with silver-coloured aluminium shift paddles hints at the thrilling driving experience in store,



The AMG instrument cluster in the SL 65 AMG

as do the AMG instrument cluster with the “AMG V12 BITURBO” start-up display and the AMG DRIVE UNIT with the E-SELECT lever which bears an embossed AMG emblem. The ambient lighting and the transparent panoramic vario-roof with roller blind also help to set the scene, while the high-end Bang & Olufsen BeoSound AMG surround sound system provides the soundtrack. High-shine chromed AMG door sill panels with white illumination, the special AMG IWC design analogue clock and AMG carbon-fibre trim complete the elegant and sporty picture.



AMG sports exhaust system with V12-design twin tailpipes

SL 65 AMG technology

With its AMG 6-litre V12 twin-turbocharged engine and AMG SPEEDSHIFT PLUS 7G-TRONIC automatic transmission, the SL 65 AMG is the flagship of the new SL model series

AMG 6-litre V12 twin-turbocharged engine. The high-performance engine, which includes the ECO start/stop function, impresses with its excellent performance data and innovative technology. The 12-cylinder design ensures perfectly smooth running. This top-of-the-range model develops 463 kW (630 hp) and a maximum torque of 1000 Nm. It attains its maximum torque at just 2500 rpm and maintains it all the way to 4300 rpm.

AMG SPEEDSHIFT PLUS 7G-TRONIC automatic transmission. Equipped with four transmission modes, this unit reconciles enhanced driving dynamics with high efficiency. A rotary switch is used to select the required transmission mode: distinctly sporty or more comfort-oriented. There is also an automatic double-declutching function when downshifting, which provides an emotional sound experience as well as reducing power-off effects. This function has a positive effect when braking on the

approach to bends in particular. The transmission is matched to perfection by the AMG high-performance compound brake system. Both AMG models are equipped with this system which features large, internally ventilated and perforated brake discs all round. The Torque Vectoring Brakes offer enhanced roadholding and safety during sporty driving by distributing the power to the wheels selectively.

AMG sports suspension. Like the SL 63 AMG, the SL 65 AMG is equipped with the AMG sports suspension, based on Active Body Control ABC, and AMG speed-sensitive sports steering.

Electronic Stability Program ESP®. The SL 63 AMG and the SL 65 AMG are equipped with 3-stage ESP®, which allows three different control strategies offering both safety and driving enjoyment to be selected at the touch of a button. Using the ESP® switch, the driver can choose between “ESP ON”, “ESP SPORT HANDLING MODE” and “ESP OFF”.



A first in a 12-cylinder model from Mercedes-Benz: AMG SPEEDSHIFT PLUS 7G-TRONIC automatic transmission



The AMG 6-litre V12 twin-turbocharged engine with 463 kW (630 hp) and 1000 Nm of torque

AMG Performance Studio

The sporty look of the AMG models is given the perfect finishing touch with the individualisation options from the AMG Performance Studio

The AMG Performance Studio offers many possibilities – a notable example being the AMG Performance package for the SL 63 AMG. This comprises an increase in output of 20 kW¹ (27 hp) and 100 Nm¹, the AMG performance steering wheel in nappa leather/DINAMICA microfibre, a spoiler lip and engine cover in carbon fibre, red painted brake callipers at the front and rear and an AMG rear-axle differential lock. The sporty theme is continued by the AMG 10-spoke forged wheels, either painted titanium grey

with a high-shine finish or painted matt black, with 255/35 R 19 front tyres and 285/30 R 20 rear tyres. The new AMG Performance Media feature displays and evaluates current vehicle data as well as lap and sector times. The optional AMG ceramic high-performance compound brake system offers not only the best possible deceleration performance and greater resistance to fading, but also greater agility, improved ride comfort and reduced road roar and tyre vibration as a result of the lower unsprung

rotational masses. For those seeking an even sportier driving experience, the new SL 63 AMG is available with the AMG performance suspension.

¹ Rated output: 415 kW (564 hp), rated torque: 900 Nm, acceleration from 0 to 100 km/h: 4.2 s



The SL 63 AMG with AMG Performance package



AMG 10-spoke forged wheels



AMG ceramic high-performance compound brake system



The AMG Performance package meets the most demanding requirements

Standard equipment | Selection



A world first: MAGIC VISION CONTROL adaptive wiper system



Instrument cluster with colour display



Intelligent Light System



Suspension with Adaptive Damping System ADS



Selector lever in the centre console



Multifunction sports steering wheel in nappa leather with shift paddles

Optional extras | Selection



KEYLESS-GO Convenience w. HANDS-FREE ACCESS (SL 65 AMG: stand.)



Electrically operated draught-stop



Seats with AIRSCARF nozzles (standard on SL 65 AMG)



COMAND Online with 6-disc DVD changer (standard from SL 500)



Bang & Olufsen BeoSound AMG (standard on SL 65 AMG)



Panoramic vario-roof with MAGIC SKY CONTROL

AMG Sports package – exterior

Athletic, dynamic, powerful. The optional AMG Sports package brings out these characteristics even more potently

The AMG Sports package is the right choice for those who wish to bring out the sportiness and dynamism of the new SL Roadster even more emphatically. The AMG bodystyling comprising front and rear aprons as well as side skirts underlines the strength and athleticism inherent in the vehicle's character. AMG light-alloy wheels with

255/35 R 19 tyres at the front and 285/30 R 19 tyres at the rear complement the overall look. Driving pleasure in its purest form is assured by the 7G-TRONIC PLUS transmission, with shift points optimised for sporty performance in the S transmission mode, and the sports suspension which is lowered by 10 millimetres and has a stiffer spring

response and damping setup (non-mandatory feature, not available in conjunction with ABC). The updated braking system, which also features perforated brake discs at the rear as well as "Mercedes-Benz" lettering on the grey painted brake callipers, completes the AMG Sports package to perfection.



The distinctive rear apron – part of the AMG Sports package



AMG 5-spoke light-alloy wheels, high-shine



The AMG Sports package offers exclusive sportiness for the new SL

AMG Sports package – interior

The powerful character of the new SL Roadster with the optional AMG Sports package is also reflected systematically in the vehicle interior

The interior concept of the AMG Sports package also impresses with sporty details. Appointments and equipment specific to this package include the instrument cluster with its “Chequered Flag” design, the sports steering wheel with a flattened bottom section as well

as silver-coloured shift paddles and perforated leather in the grip area, and the sports seats with their vertical fluting which are available in leather, nappa leather or Exclusive nappa leather (black and perforated in each case). White piping on the door armrests, centre console, seat

side bolsters and head restraints provides an attractive contrast. The trim is available in a choice of light or dark longitudinal-grain aluminium. AMG floor mats are another exclusive feature of this package.



The instrument cluster with its “Chequered Flag” design



Interior features of the AMG Sports package



Sportiness and dynamism abound in the interior of the roadster with the AMG Sports package



designo

A wealth of high-grade appointments and special details makes designo an alluring proposition → www.mercedes-benz.com/designo

The optional designo range allows you to take the sporty design of the new SL Roadster into another dimension of perfection. The comprehensive designo line-up offers discerning customers a choice of attractive upholstery in designo leather as well as numerous variant headlining options in DINAMICA microfibre or leather. designo trim,

which is manufactured with the greatest care, is available in natural bamboo, black piano lacquer, champagne white piano lacquer or AMG carbon fibre. The two-tone designo leather steering wheel is optionally available in all eight designo interior colours. Five exclusive designo paint finishes focus attention on the exterior design. The range

comprises two designo metallic paint finishes, two designo magno matt paint finishes or the sporty designo zircon red. Whether the effect being sought is a harmonious combination of colours or contrasting highlights, designo underlines the exclusivity of the new SL.



Trim in designo black piano lacquer (Code W69)



designo leather headlining



designo seat belts in red

Upholstery and trim



The black colour scheme features black seats which are available either in leather/fabric or, as an option, in leather, nappa leather or Exclusive nappa leather. The contrasting topstitching in dark alpaca grey adds an eye-catching note in combination with leather/fabric or leather. Where nappa leather or Exclusive nappa leather is specified, black topstitching and dark alpaca grey piping underline the stylish character of the interior. The centre console is in machined aluminium as standard, the metallic surfaces in fine silver chrome.

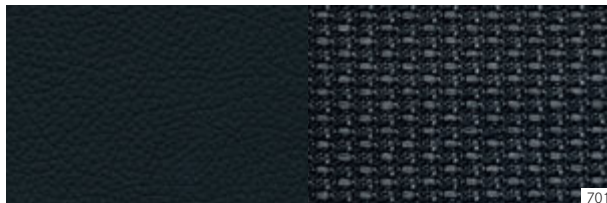

701



201

801
501

H76



736



739



731



729

black

- 701 Leather/fabric
 - 201 Leather
 - 801 Nappa leather
 - 501 Exclusive nappa leather
-

Trim

- H76 dark longitudinal-grain aluminium (option, with AMG Sports package)
 - 736 high-gloss black ash wood (option)
 - 739 light longitudinal-grain aluminium
 - 731 high-gloss brown burr walnut wood (option)
 - 729 satin-finish light brown poplar wood (option)
-



The nut brown colour scheme features nut brown seats which are available in nappa leather or Exclusive nappa leather. The topstitching of the seat surfaces is in brown, the contrasting stitching on the side bolsters in black. Black piping adds an eye-catching note. The centre console is in machined aluminium as standard, the metallic surfaces in fine silver chrome.

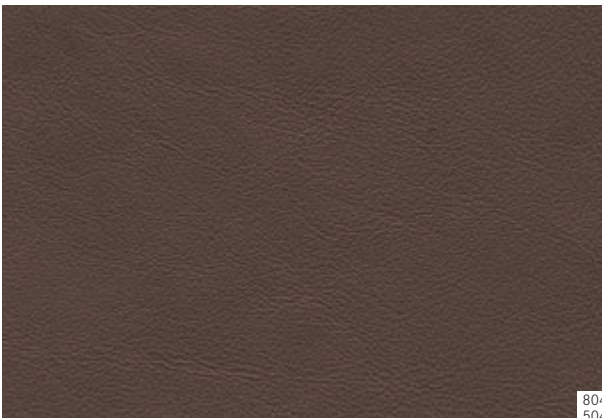

804
504



736



739



731



729

nut brown (option)

804 Nappa leather

504 Exclusive nappa leather

Trim

736 high-gloss black ash wood (option)

739 light longitudinal-grain aluminium

731 high-gloss brown burr walnut wood (option)

729 satin-finish light brown poplar wood (option)



The ginger beige/espresso brown colour scheme features ginger beige seats which are available in leather, nappa leather or Exclusive nappa leather. Sahara beige contrasting topstitching adds an eye-catching note. Where nappa leather or Exclusive nappa leather is specified, piping in espresso brown underlines the stylish character of the interior. The centre console is in machined aluminium as standard, while the metallic surfaces are in fine silver chrome.

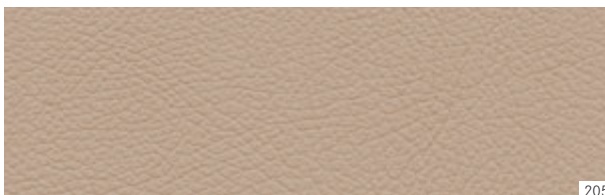

205



736

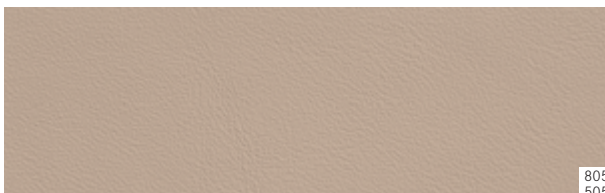

739

805
505

731



729

ginger beige/espresso brown (option)

- 205 Leather
 - 805 Nappa leather
 - 505 Exclusive nappa leather
-

Trim

- 736 high-gloss black ash wood (option)
 - 739 light longitudinal-grain aluminium
 - 731 high-gloss brown burr walnut wood (option)
 - 729 satin-finish light brown poplar wood (option)
-



The bengal red colour scheme features bengal red seats which are available in leather, nappa leather or Exclusive nappa leather. Black contrasting topstitching adds an eye-catching note in combination with leather. Where nappa leather or Exclusive nappa leather is specified, black topstitching and black piping underline the stylish character of the interior. The centre console is in machined aluminium as standard, the metallic surfaces in fine silver chrome.



207



736



739

807
507

731



729

bengal red (option)

207 Leather

807 Nappa leather

507 Exclusive nappa leather

Trim

736 high-gloss black ash wood (option)

739 light longitudinal-grain aluminium

731 high-gloss brown burr walnut wood (option)

729 satin-finish light brown poplar wood (option)



The crystal grey colour scheme features crystal grey seats which are available in embossed leather. Mid grey contrasting topstitching adds an eye-catching note. The centre console is in machined aluminium as standard, the metallic surfaces in fine silver chrome.

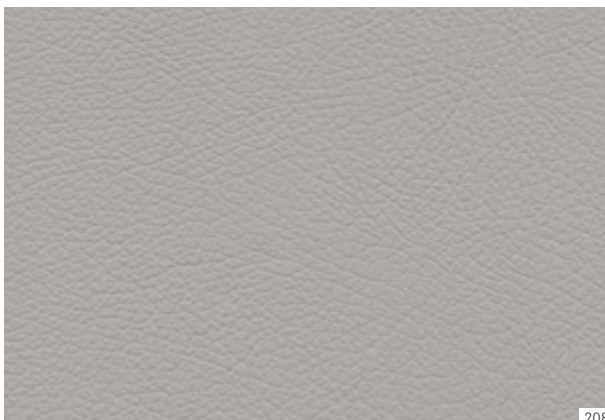

208



736



739



731



729

crystal grey (option)

208 Leather

Trim

736 high-gloss black ash wood (option)

739 light longitudinal-grain aluminium

731 high-gloss brown burr walnut wood (option)

729 satin-finish light brown poplar wood (option)



The porcelain colour scheme features porcelain coloured seats which are available in nappa leather or Exclusive nappa leather. Black piping with porcelain coloured top-stitching adds an eye-catching note. The centre console is in machined aluminium as standard, the metallic surfaces in fine silver chrome.

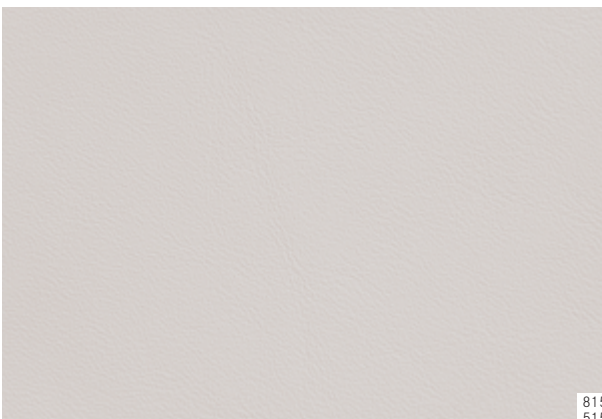

815
515



736



739



731



729

porcelain (option)

815 Nappa leather

515 Exclusive nappa leather

Trim

736 high-gloss black ash wood (option)

739 light longitudinal-grain aluminium

731 high-gloss brown burr walnut wood (option)

729 satin-finish light brown poplar wood (option)

Wheels



10-spoke light-alloy wheels, painted titanium silver, with 255/45 R 17 tyres (standard for SL 350, Code 25R)



5-twin-spoke light-alloy wheels, painted vanadium silver with a high-sheen finish, with 255/40 R 18 front tyres and 285/35 R 18 rear tyres (option, Code R70)



15-spoke light-alloy wheels, painted vanadium silver, with 255/40 R 18 tyres (standard for SL 500, Code R34)



5-twin-spoke light-alloy wheels, painted vanadium silver, with 255/35 R 19 front tyres and 285/30 R 19 rear tyres (option, Code R17)



AMG 5-spoke light-alloy wheels with a high-sheen finish, with 255/35 R 19 front tyres and 285/30 R 19 rear tyres (component of AMG Sports package, Code 770)



AMG 5-spoke light-alloy wheels, painted titanium grey with a high-sheen finish, with 255/35 R 19 front tyres and 285/30 R 19 rear tyres (standard for SL 65 AMG, Code 797)



AMG 10-spoke forged wheels, painted matt black, rim flange with a high-sheen finish, with 255/35 R 19 front tyres and 285/30 R 20 rear tyres (option, only for AMG models, Code 767)



AMG 5-twin-spoke light-alloy wheels, painted titanium grey with a high-sheen finish, with 255/35 R 19 front tyres and 285/30 R 19 rear tyres (standard for SL 63 AMG, Code 793)



AMG 10-spoke forged wheels, painted titanium grey with a polished finish, with 255/35 R 19 front tyres and 285/30 R 20 rear tyres (option, only for AMG models, Code 766)



Multi-spoke light-alloy wheels with 255/35 R 19 front tyres and 285/30 R 19 tyres optionally available for the rear (ex-factory accessory wheel, Code 11R)

Genuine accessories

The Mercedes-Benz genuine accessories range offers everything you need to make the new SL even sportier: a whole host of accessory products optimally tailored to the vehicle → www.mercedes-benz-accessories.com



Distinctive 5-spoke light-alloy wheels with 225/40 R 18 front tyres and 285/35 R 18 tyres optionally available for the rear

Make your roadster even more emphatically your own. Make a distinctive visual statement with your choice of light-alloy wheels, or add practical accessories to enhance the functionality of your SL. All the products are matched perfectly to your vehicle and are engineered to the highest standards of quality and safety. Examples of the accessories available include the specially designed cradle for your iPhone® which, in conjunction with the Convenience Telephony option (Code 386), automatically links it with your vehicle's hands-free system. As well as providing optimum reception quality, battery charging and access to the internal phone memory, the system allows the phone to be operated conveniently by means of the vehicle controls. Cradles are available for many popular mobile phones.

Experience a new dimension of web access, telephony and navigation support in your SL with the combination of the Mercedes-Benz Bluetooth® (SAP) telephone module and the COMAND Online multimedia system. The telephone module with integral UMTS module and a direct connection to the vehicle aerial ensures that COMAND Online has a fast, stable and reliable internet connection. You can use the phone and simultaneously use Mercedes-Benz Apps via COMAND Online and have the system read SMS messages to you. The telephone module is easily linked with the Convenience Telephony feature in the centre armrest.

The practical boot tub matches the shape of the boot precisely. It is flat, very easy to clean and made from food-safe material. The ribbed texture of the tub helps prevent the load from sliding.

To find out more, please see our Accessories brochure or consult your authorised Mercedes-Benz dealer who will be pleased to advise you.



Practical: the flat boot tub

Services

MercedesCard. As a VISA credit card, this is an internationally accepted means of payment that can offer you a host of additional benefits, such as the Mercedes-Benz insurance package or other exclusive insurance products. There's also the Mercedes-Benz magazine to inspire you with its fascinating features and reports. Further details are available from your Mercedes-Benz dealer.

Mercedes-Benz Financial Services. Mercedes-Benz stands for quality, innovation and safety – and the same applies to Mercedes-Benz Financial Services. Our innovative leasing and financing products are tailored to your financial needs and means, making it easy for you to secure the keys to your dream car. Once you are on the road, our insurance products offer you comprehensive protection on every trip. Finally, our service products ensure that your car is always in tip-top condition while keeping costs transparent and easily manageable. For a detailed quotation, please contact your authorised Mercedes-Benz dealer, who will be pleased to go through the latest financial services and terms and conditions with you.

Mercedes-Benz mobility. Your new car comes complete with the promise of feeling safe on the road. But if you should ever need assistance, Mercedes-Benz Service24h is there to help. Just call the freephone service hotline on 00800 1 777 7777¹. The integrated telematics service, Mercedes-Benz Contact², is even more convenient: a touch of a button is all it takes to contact the Mercedes-Benz customer centre. If you wish, relevant vehicle and position-related data are transmitted at the same time, thereby allowing the centre to react quickly and provide rapid on-site assistance. Also standard with your new car at no extra charge is the Mercedes-Benz Mobilo³ mobility package. Whether you have lost your key, had a breakdown which cannot be repaired immediately or suffered damage to the vehicle due to an accident or vandalism, Mobilo helps you reach your destination – anywhere in Europe. Whatever is holding you up, you will soon be able to resume your journey.

Mercedes-Benz Museum. Discover what has been moving the world for over 125 years, and embark on a fascinating journey through automotive history in the Mercedes-Benz Museum. More than 1500 exhibits covering an area of 16,500 square metres chart the unique heritage and innovative flair of the inventor of the motor car. From the very

first model through to the very latest, you will find one legendary car after another awaiting you. The museum is a spectacular sight in its own right too, thanks to an architecture that breaks away from traditional concepts and creates an unprecedented sense of space. Welcome to the Mercedes-Benz Museum – a world of innovation. www.mercedes-benz-classic.com/museum

Test drive. The unique feeling of driving a Mercedes cannot be put into words – you have to experience it for yourself. Take a test drive and find out first hand how it feels to drive your dream car. Please contact your nearest Mercedes-Benz dealer for details.



¹ Alternative: +49 69 95 30 72 77 ² Requires a factory-fitted radio, connected to an operational mobile phone. The only charge incurred is the cost of the mobile phone call to the landline network ³ Once the mobility guarantee has expired (four years), Mobilo can be extended to provide cover in the event of breakdown and insurance claims one year at a time for a maximum of 30 years, provided that regular maintenance is carried out by your Mercedes-Benz service partner

Interactive Owner's Manual and Mercedes-Benz Guides.

The website also offers an interactive tour, enabling you to acquaint yourself with your dream car. You can view key functions in detail, gain an insight into the car's inner workings or look at the benefits of each model. For further details, go to www.mercedes-benz.de/owners-manual. The "Mercedes-Benz Guides" app lets you explore the highlights of the individual models both online and offline. The app is available free of charge from the Apple® iTunes® Store (iOS) as well as the Google Play store (Android).

Mobile internet. The entire world of Mercedes-Benz can be accessed at any time with your web-capable mobile device - including specially adapted content for both smartphones and tablets. As well as an overview of all the passenger car models, there are insights into the entire brand world along with a wealth of entertainment offers and direct links to our range of services at www.mercedes-benz.com

Mercedes-Benz service contracts. Vehicle-specific service contracts allow you to arrange individual cover for your Mercedes: for a small monthly premium, the Excellent service contract covers all service jobs including maintenance, wear and repairs for up to five years. Simply present your service card and you will be safe from any unwelcome financial surprises - and you can relax in the knowledge that your Mercedes will stay on top form for a long time to come. The Advance service contract provides a warranty extension, so you will be protected against unexpected repair costs even after the manufacturer's warranty or the Excellent service contract has expired - for up to ten years.



Accident repairs. Should the worst happen and you find yourself in need of repairs, with the Mercedes-Benz accident repair service you will receive the best possible assistance for your vehicle and ensure that its high-quality safety features are properly maintained. Whether you need paint, body or glass repair work carried out, the highly trained specialists at your Mercedes-Benz service partner will repair your Mercedes-Benz and get you quickly back on the road again. Further information is available from your authorised Mercedes-Benz dealer.



Dimensions

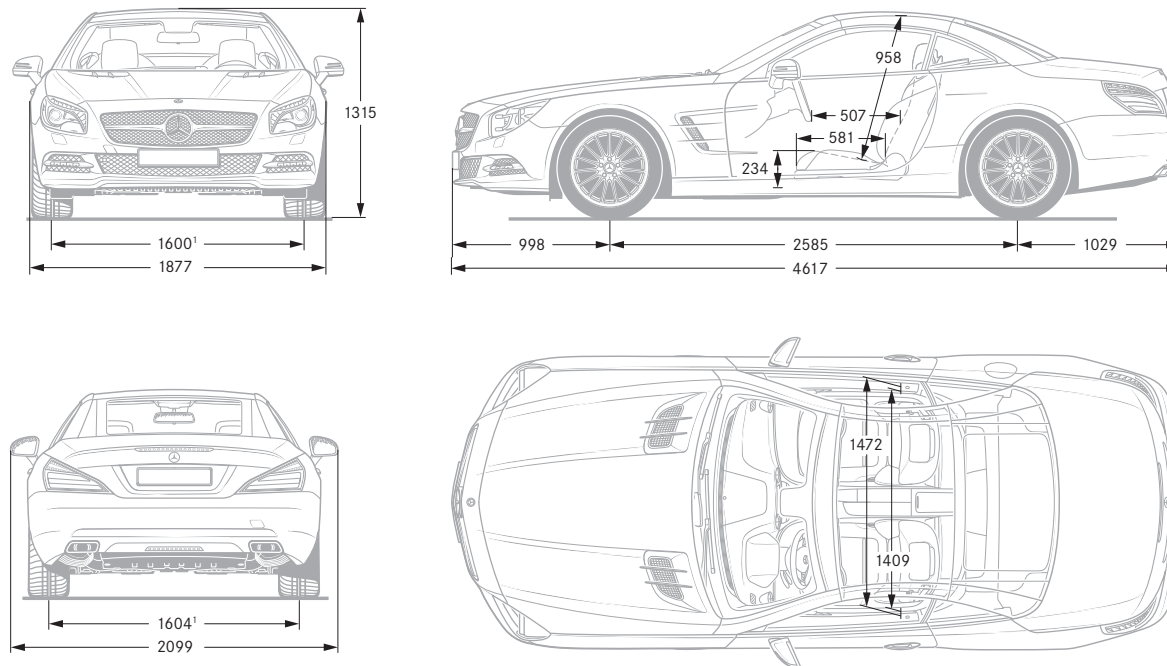

All measurements in millimetres. The dimensions shown are mean values and apply to standard-specification, unladen vehicles
¹ Carrying 2 people, each weighing 68 kg

Paintwork

Non-metallic paints (standard)

- 040 black
- 590 fire opal

Metallic paints (option)

- 183 magnetite black
- 197 obsidian black
- 526 dolomite brown
- 755 tenorite grey
- 775 iridium silver
- 792 palladium silver
- 794 pearl beige
- 799 diamond white metallic BRIGHT

Special paints (option)

- 057 designo zircon red metallic
- 281 cerussite grey metallic SHAPE

Further individual paint finishes can be found in the designo range

Technical data

No. of cylinders/arrangement
Total displacement in cc
Rated output ¹ in kW (hp) at rpm
Rated torque in Nm at rpm
Acceleration from 0 to 100 km/h in s
Top speed, approx. in km/h
Fuel consumption ⁴ in l/100 km
Urban
Extra-urban
Combined
CO ₂ emissions ⁴ in g/km combined
Emission class
Tank capacity in l/of which approx. reserve
Boot capacity in l
with roof closed
with roof open
Turning circle diameter in m
Kerb weight ⁵ in kg
Perm. GVW in kg

Petrol engines

SL 350 BlueEFFICIENCY

6/V
3498
225 (306)/6500
370/3500-5250
5.9
250³

9.9-9.3
6.1-5.4
7.5-6.8

176-159

Euro 5

65/8.0

504

364

11.04

1685

2065

SL 500 BlueEFFICIENCY

8/V
4663
320 (435)/5250
700/1800-3500
4.6
250³

12.9-12.7

7.1-7.0

9.2-9.1

214-212

Euro 5

65/8.0

504

364

11.04

1785

2165

¹ Figures in accordance with Directive 80/1269/EEC in the currently applicable version ² The figures in square brackets apply to vehicles with the AMG Performance package ³ Electronically governed ⁴ The figures shown were obtained in accordance with the prescribed measuring process (Directive [EC] 715/2007 in the currently applicable version). The figures are not based on an individual model and do not constitute part of the product offer; they are provided solely for purposes of comparison between different vehicle models ⁵ Figures according to Directive 92/21/EC, version 95/48/EC (kerb weight with fuel tank 90% full, driver, 68 kg, and luggage, 7 kg) for standard-specification vehicles. Optional extras and accessories will generally increase this figure and reduce the payload capacity accordingly
Further technical data can be found at www.mercedes-benz.com

	AMG engines	
	SL 63 AMG	SL 65 AMG
No. of cylinders/arrangement	8/V	12/V
Total displacement in cc	5461	5980
Rated output ¹ in kW (hp) at rpm	395 (537)/5500 [415 (564)/5500] ²	463 (630)/4800
Rated torque in Nm at rpm	800/2000-4500 [900/2250-3750] ²	1000/2300-4300
Acceleration from 0 to 100 km/h in s	4.3 [4.2] ²	4.0
Top speed, approx. in km/h	250 ³ [300 ³] ²	250 ³
Fuel consumption ⁴ in l/100 km		
Urban	13.9	17.0
Extra-urban	7.6	8.4
Combined	9.9	11.6
CO ₂ emissions ⁴ in g/km combined	231	270
Emission class	Euro 5	Euro 5
Tank capacity in l/of which approx. reserve	75/14	75/14
Boot capacity in l		
with roof closed	504	504
with roof open	364	364
Turning circle diameter in m	11.1	11.1
Kerb weight ⁵ in kg	1845	1950
Perm. GVW in kg	2180	2210

Non-metallic paints

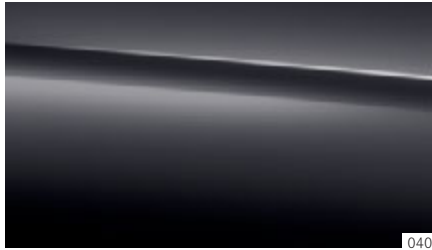

040

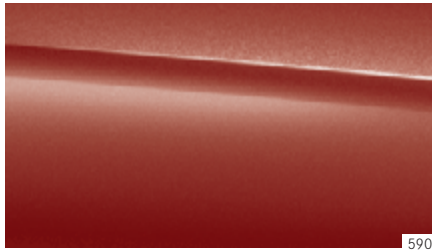

590

Metallic paints

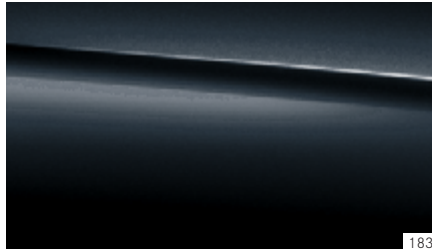

183

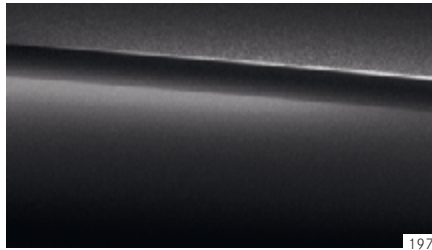

197

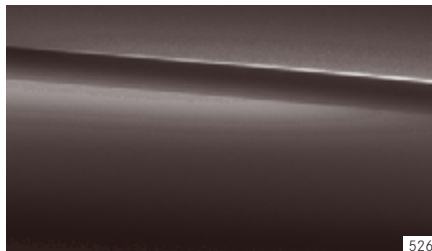

526

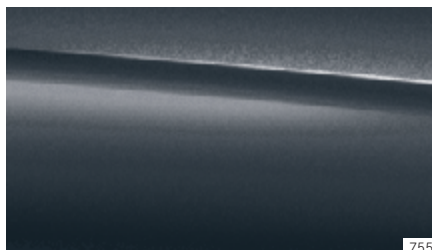

755

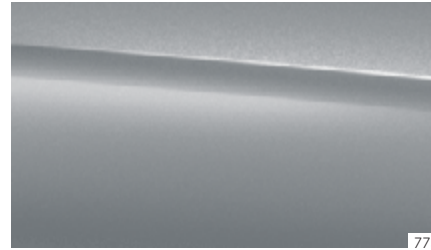

775

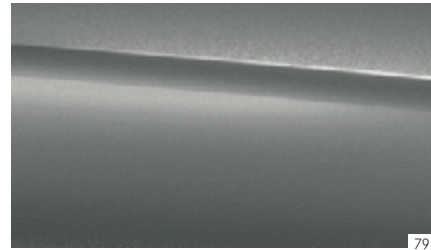

792

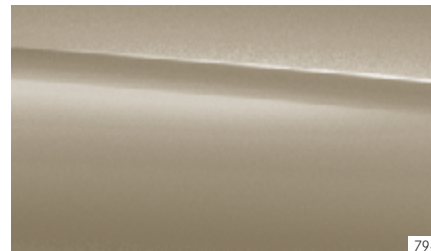

794



799

Special paints

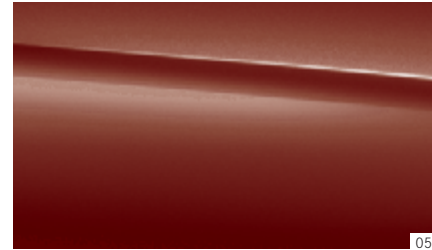

057

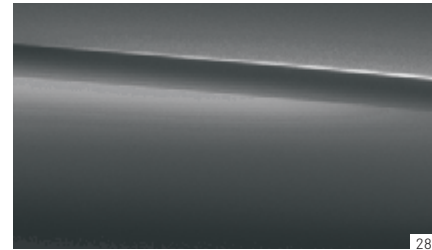

281

Take-back of end-of-life vehicles. You can return your SL-Class to us for environment-friendly disposal in accordance with the European Union (EU) End-Of-Life Vehicle Directive. But that day lies a long way off.

A network of vehicle take-back depots and dismantlers has been established to make it as easy as possible for you to return your vehicle. You can leave it at any of these points free of charge and, by doing so, make an important contribution to completing the recycling process and conserving resources.

For further information about the recycling and disposal of end-of-life vehicles, and the take-back conditions, please visit the national Mercedes-Benz website.

Please note: changes may have been made to the product since this brochure went to press (11.07.2012). The manufacturer reserves the right to make changes to the design, form, colour and specification during the delivery period, provided these changes, while taking into account the interests of the vendor, can be deemed reasonable with respect to the purchaser. Where the vendor or the manufacturer uses symbols or numbers to describe an order or the subject of an order, no rights may be derived solely from these. The illustrations may show accessories and items of optional equipment which are not part of standard specification. Colours may differ slightly from those shown in the brochure, owing to the limitations of the printing process. This brochure is distributed internationally. It provides a general indication of the range of models, features, optional extras and/or colours available in various countries. Some of the models, features, optional extras and/or colours shown may not be available in your country or may only be available in a different specification. Additionally some models, features, optional extras and/or colours may only be available in combination with others. For current and more specific information in relation to the range of models, features, optional extras and/or colours available in your country, and their pricing, you should contact your nearest authorised Mercedes-Benz Passenger Car Dealer.

www.mercedes-benz.com