



Technical Service Bulletin

SUBJECT:		No: TSB-15-23-003	
NOISE FROM CVT AT ALL ENGINE SPEEDS		DATE: February, 2015	
		MODEL: See below	
CIRCULATE TO:	<input type="checkbox"/> GENERAL MANAGER	<input checked="" type="checkbox"/> PARTS MANAGER	<input checked="" type="checkbox"/> TECHNICIAN
<input checked="" type="checkbox"/> SERVICE ADVISOR	<input checked="" type="checkbox"/> SERVICE MANAGER	<input checked="" type="checkbox"/> WARRANTY PROCESSOR	<input type="checkbox"/> SALES MANAGER

PURPOSE

A clicking noise (along with whining/humming), directly related to vehicle speed, is heard in the passenger compartment. As vehicle speed increases, the clicking speed increases (engine speed has no effect on the noise). Due to engine and road noises, the sound typically cannot be heard at vehicle speeds above 40 MPH. Click the following speaker icon to hear to an audible recording of the noise. 

This TSB provides instructions to remove the transmission and replace two primary pulley shaft bearings and one secondary pulley shaft bearing.

AFFECTED VEHICLES

2008–2010 Outlander built prior to October 1, 2010
 2008–2010 Lancer built prior to October 1, 2010
 2009–2010 Lancer Sportback built prior to October 1, 2010
 2011 Outlander Sport equipped built prior to October 1, 2010

OVERVIEW

Prior to removal, drain the transaxle and remove the oil pan. Inspect the two magnets in the pan for debris and foreign material. Compare the magnets to the photos below.



If the magnets show typical accumulation as shown above, reinstall the pan and perform this TSB to replace the pulley bearings.



If the magnets show foreign material along with typical accumulation, reinstall the pan and replace the CVT assembly.

Following is a brief outline of the repair steps contained in this TSB. Specific procedures to be followed after the transaxle has been removed begin on page 3.

- Transaxle Disassembly (page 3)
- Side Cover Disassembly (Page 13)
- Cleaning (page 15)
- Case Seals and O-Rings (page 17)
- Bearing Replacement (page 17)
- Transaxle Reassembly (page 26)
- Transaxle Flushing (page 40)

Technician Note:

If additional components are found defective while performing this TSB, proceed with repairs as needed.

TOOLS:

In addition to the CVT special tools specified in the service manual Group 23B, the following tools are required to complete this repair.

NOTE: A limited quantity of the following special tools are available USED at a substantial savings. Place an order through your facing PDC.

<u>Number</u>	<u>Description</u>	<u>Number</u>	<u>Description</u>
MB990847-01	Installer	MB995049-01	Press Button
MB991448-01	Bushing Remover and Installer Base	MD998412	Guide Pins
MB992140-01	Oil Sealer Installer	MD998824-01	50mm Adapter
MB991389-01	Remover Base Bushing	MD998829-01	Installer Adapter
MLR-C-4660-A	Roller Bearing Puller	MD998917-01	Remover
MB992984	Compressor Set, Pulley Piston	MIT304180-A	Installer
MB992985	CVT Pulley Base (Holding Fixture)	MIT18594	Protective Sleeve
MB992986	Primary Pulley Holder (Splined Socket)		
			Common 3 Jaw Puller
			40mm 1/2" Drive Socket

Parts List:

<u>Number</u>	<u>Description</u>	<u>Quantity</u>	<u>Number</u>	<u>Description</u>	<u>Quantity</u>
2702A006	Converter Housing Seal	1	2791A029	Oil Pump Seal Rings	2
2702A014	Axle Seal	2	2800A031	Valve Seal	1
2702A078	O-ring	1	2824A006	Oil Filter	1
2705A015	Oil Pan Gasket	1	2824A007	Oil Filter	1
2761A009	O-ring	1	2920A096	O-ring	2
2771A001	Bearing Retainer	1	2931A005	Seal Rings	2
2771A002	Bearing Retainer	1	2950A047	Bearing	1
2771A003	Lock Nut	1	2950A048	Bearing	1
2771A004	Lock Nut	1	2950A049	Bearing	1
2791A012	O-rings	7	3200A103	O-ring	1
2791A014	Oil Pump Gasket	1	8652A017	O-rings	2
2791A018	Snap Ring	1	MD743612	O-ring	1
2791A024	Oil Pump Chain	1			

TRANSAXLE REMOVAL

With the transaxle still in the vehicle, unfasten the control harness cable bracket from the dipstick. Remove the dipstick and transaxle mount. Remove the transaxle from the vehicle.

Before transaxle disassembly, always clean any debris from the outside of the transaxle case.

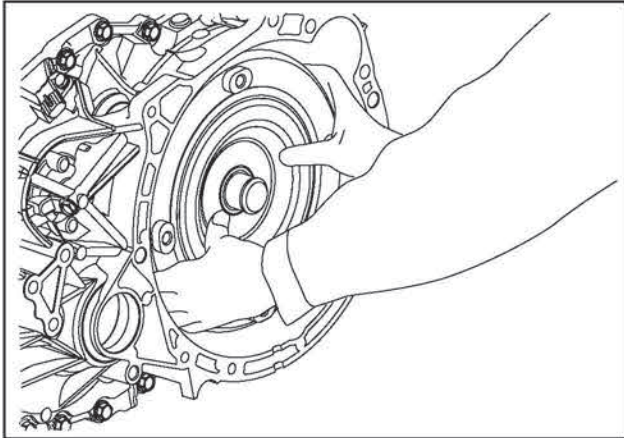

TRANSAXLE DISASSEMBLY

1. Remove the torque converter from the transaxle and drain.

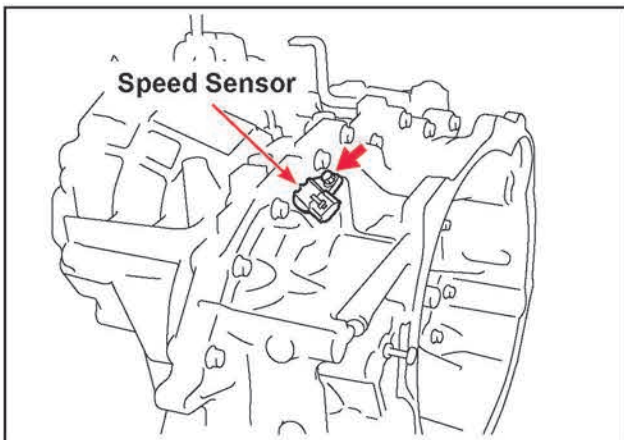

2. Remove the secondary pulley speed sensor mounting bolt.

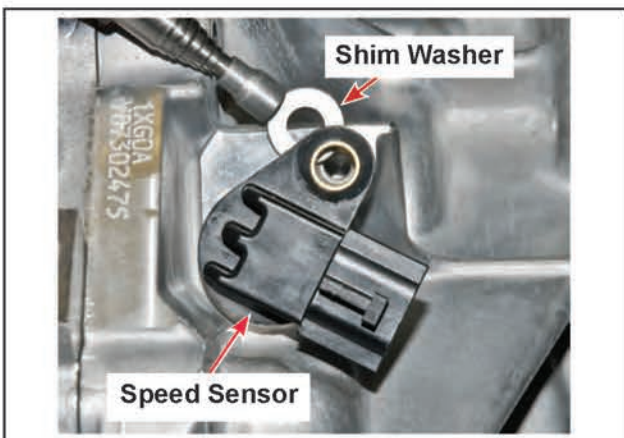

3. At the same time the secondary pulley speed sensor is being removed from the transaxle case, using a stick magnet to remove the secondary pulley speed sensor shim washer.

NOTE: If the shim washer is omitted, the speed sensor will rub against the Secondary Pulley and damage the tip of the sensor.

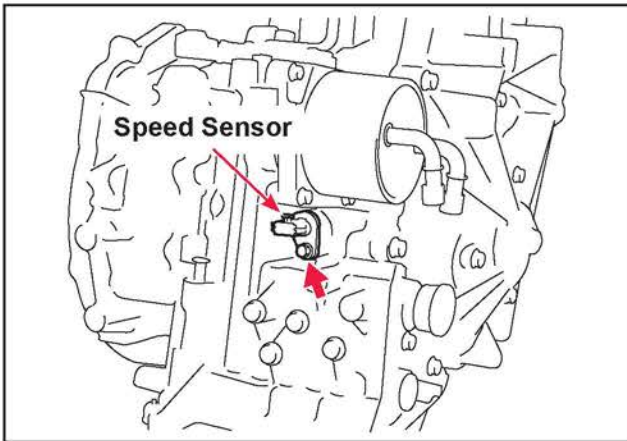

4. Remove the primary pulley speed sensor.

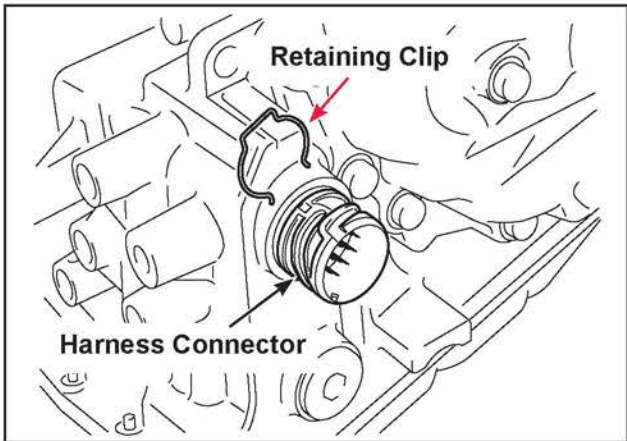

5. Remove the retaining clip from the harness connector.

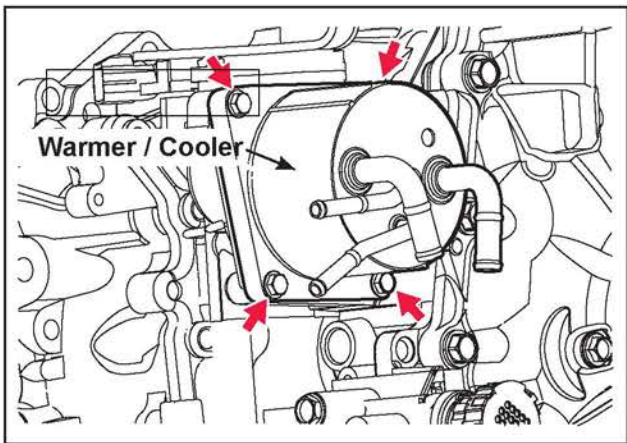

6. Remove the warmer/cooler and large o-ring.
Discard the o-ring.

CAUTION

The aluminum tubes on the warmer/cooler are very soft. Take care as not to bend, kink or crush them in any way.

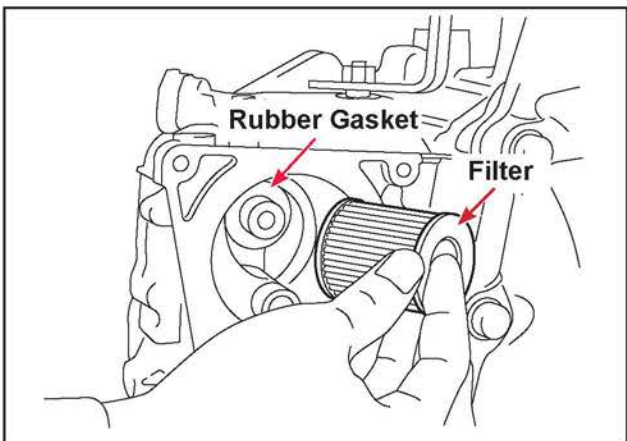

7. Remove the ATF warmer/cooler filter and rubber seal from the case and discard both.

NOTE: Verify the rubber filter seal comes out with the filter.

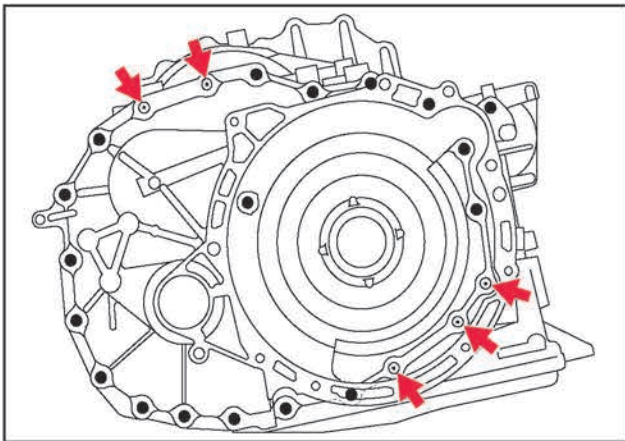

8. Rotate the transaxle on the bench so the converter housing faces up.
9. Remove the five **LONG** converter housing mounting bolts identified by the dimple located in the center of the hex head, as indicated by the arrows.

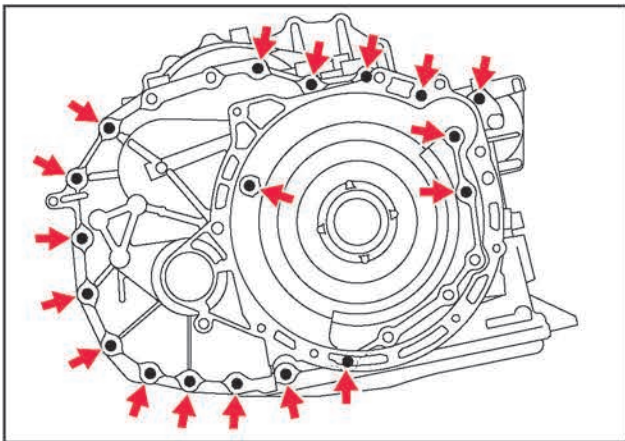

10. Remove the eighteen **SHORT** converter housing mounting bolts.

Use a deadblow mallet to carefully remove the converter housing from the transaxle case.

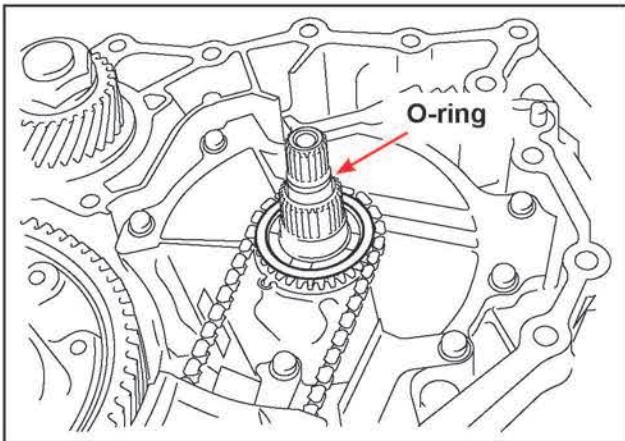

11. Remove and discard the input shaft o-ring.

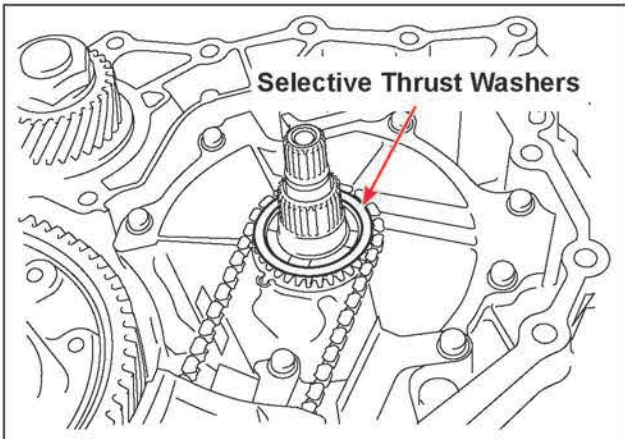

12. Remove the two selective thrust washers from the oil pump drive sprocket.

NOTE: The drive sprocket used with transaxles starting with serial # Y08808317 was redesigned which eliminated the need for selective shims.

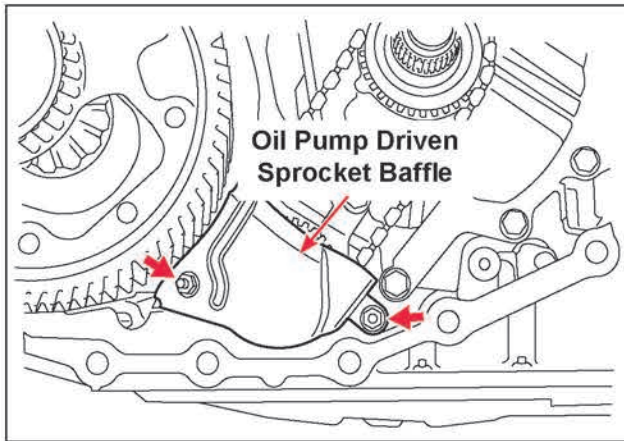

13. Remove the two oil pump driven sprocket baffle mounting nuts, then remove the baffle

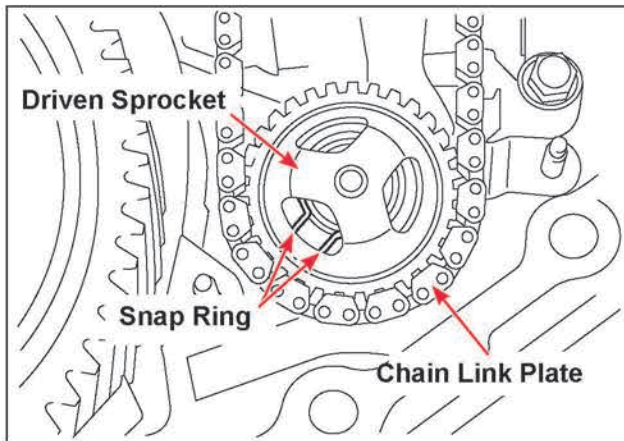

14. Rotate the oil pump driven sprocket until one of the three cutouts in the driven sprocket lines up with the opening in the snap ring.

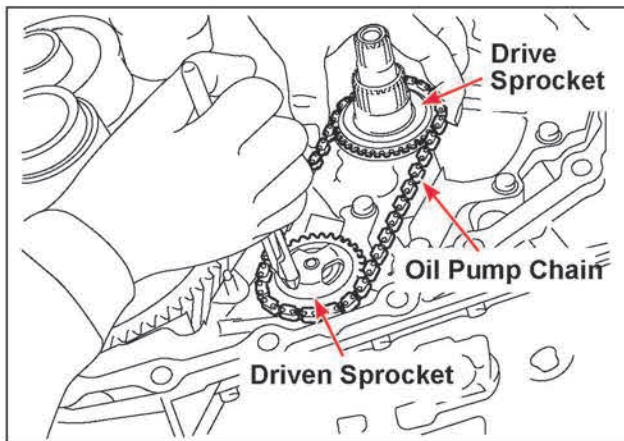

15. Using a pair of external snap ring pliers, expand the snap ring and slide both sprockets and the chain upward to remove them from the transaxle.

Discard the chain.

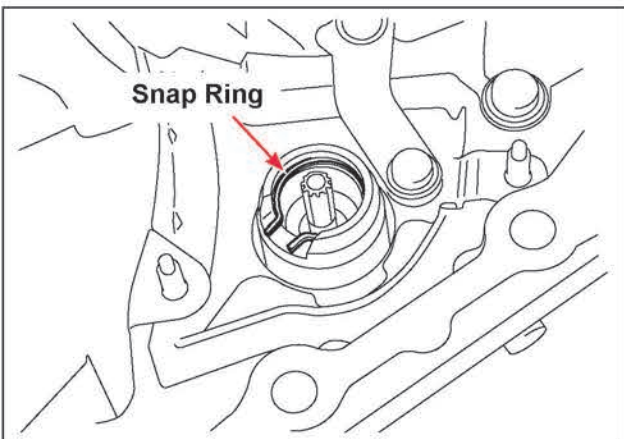

16. Remove the snap ring from the oil pump housing bearing bore.

Discard the snap ring.

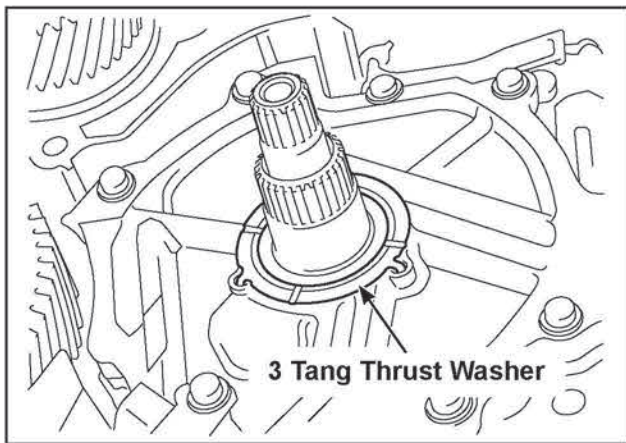

17. Remove the three tang thrust washer from the pump cover (stator support).

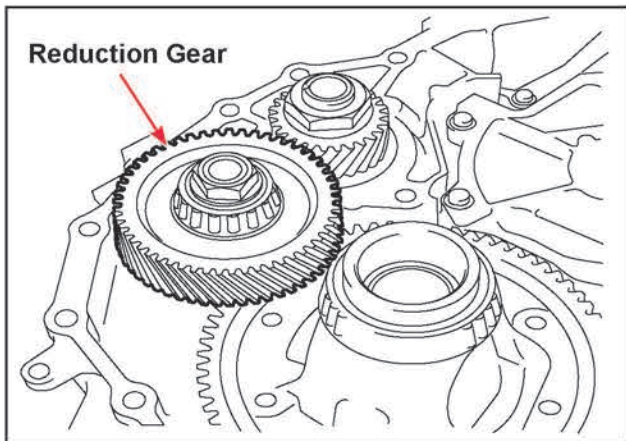

18. Remove the reduction gear assembly.

Carefully inspect the bearings for roughness or damage. Replace as necessary.

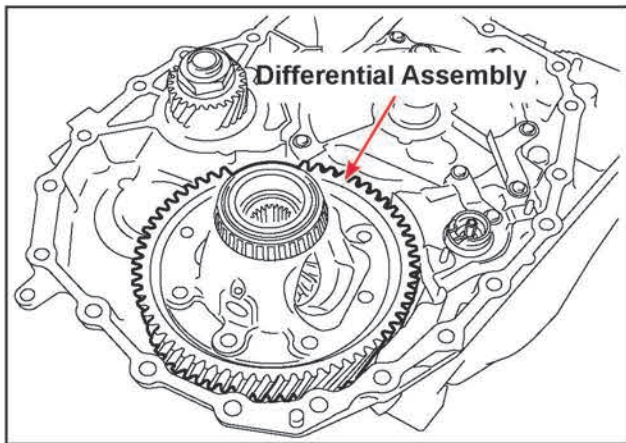

19. Remove the differential assembly.

Carefully inspect the bearings for roughness or damage. Replace as necessary.

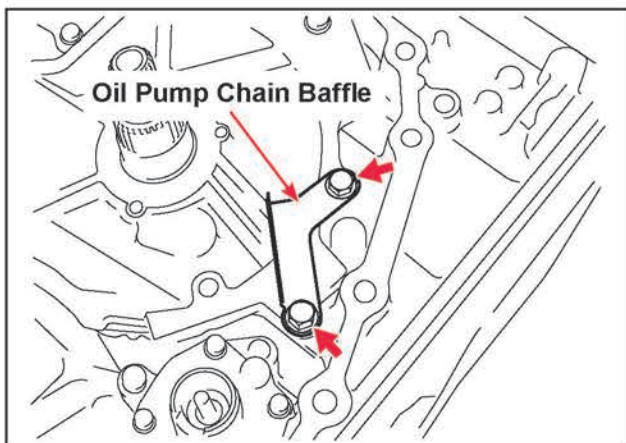

20. Remove the two oil pump chain baffle mounting bolts, then remove the oil pump chain baffle

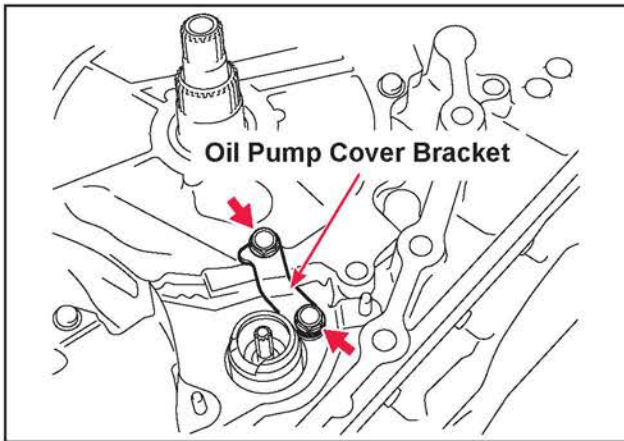

21. Remove the two oil pump to pump cover (stator support) bracket mounting bolts, then remove the bracket.

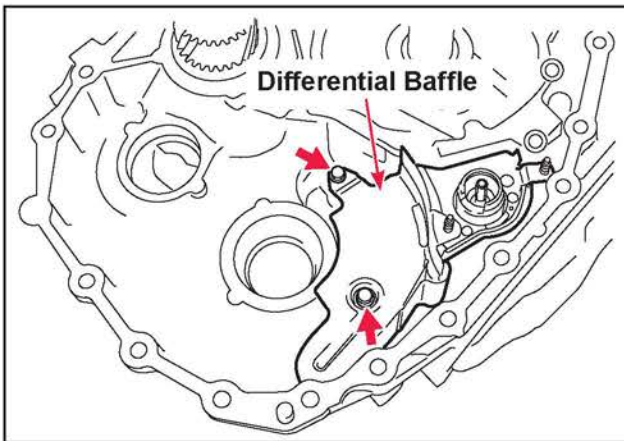

22. Remove the two differential baffle mounting bolts, then remove the baffle

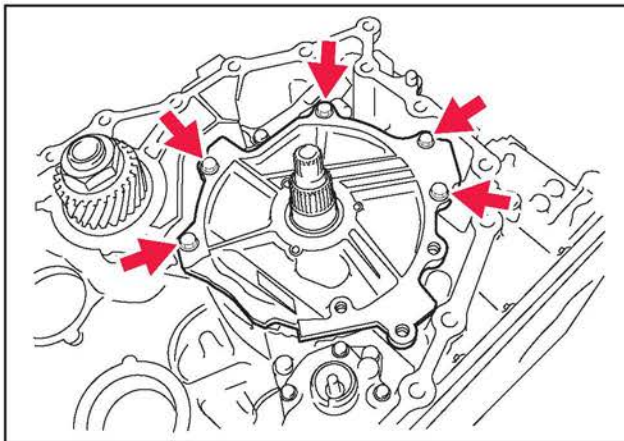

23. Remove the remaining five oil pump cover (stator support) mounting bolts, then remove the oil pump cover (Stator support) from the case.

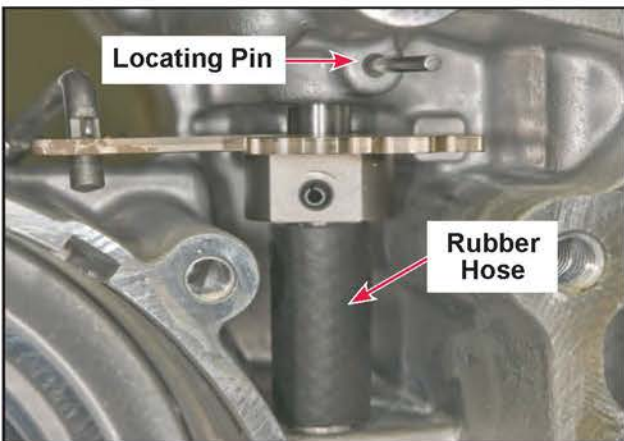

24. Cut a small piece of fuel hose and install it onto the manual control shaft as shown. Using your fingers or a stick magnet remove the manual control shaft locating pin from the case.

CAUTION

Failure to install the fuel hose will cause damage to the non-serviceable manual shaft seal.

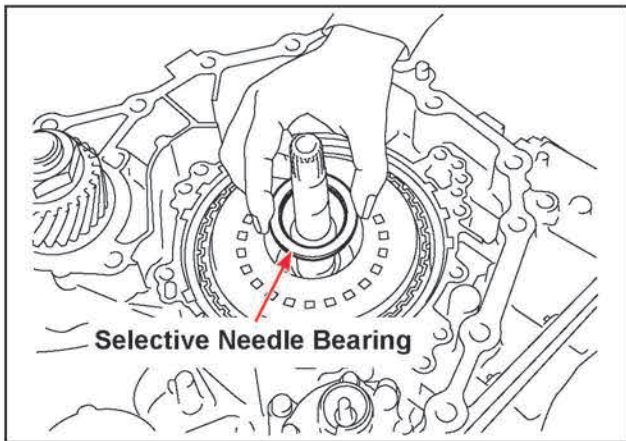

25. Remove the selective needle bearing assembly from the forward clutch drum.

NOTE: The selective needle bearing assembly may have come out with the oil pump cover (stator support).

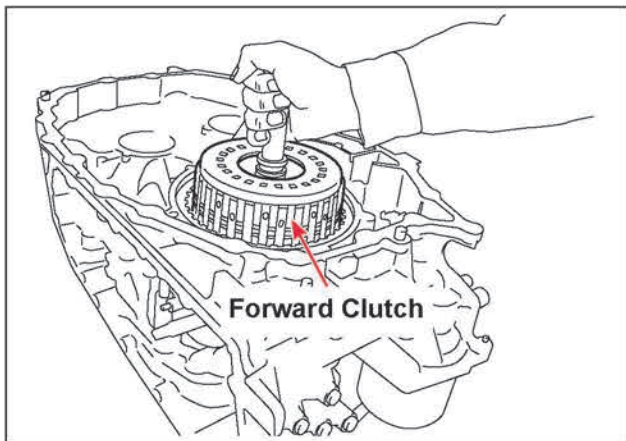

26. Remove the forward clutch drum assembly from the transaxle case.

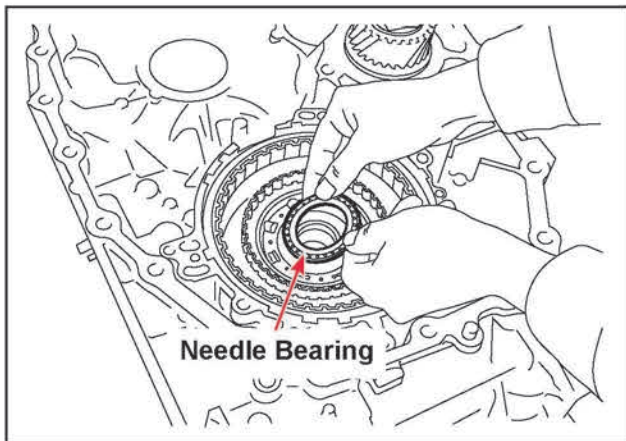

27. Remove the needle bearing assembly from the sun gear.

NOTE: The needle bearing may have come out with the forward clutch drum.

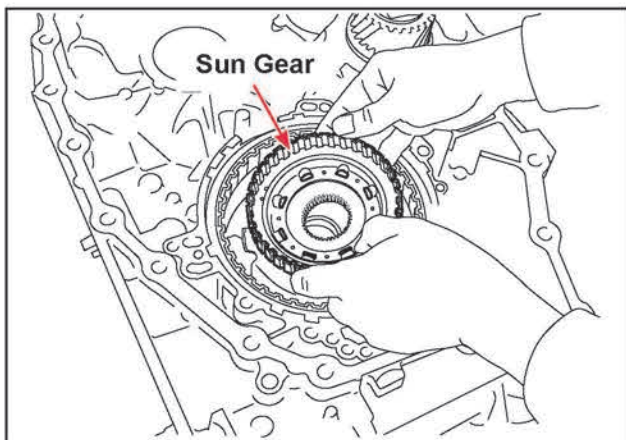

28. Remove the sun gear.

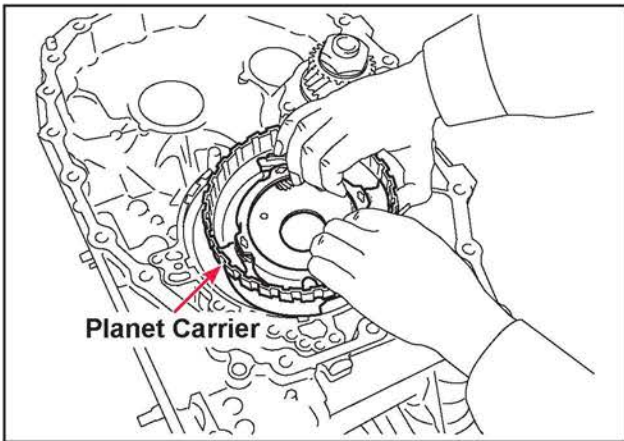

29. Remove the planet carrier (reverse brake clutch hub) assembly from the transaxle case.

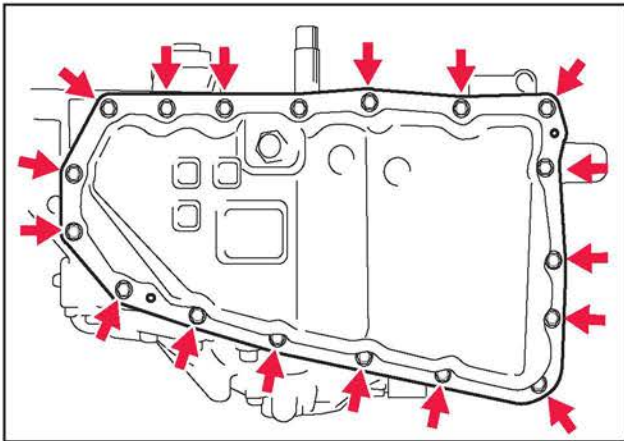

30. Remove the pan.
Discard the pan gasket.

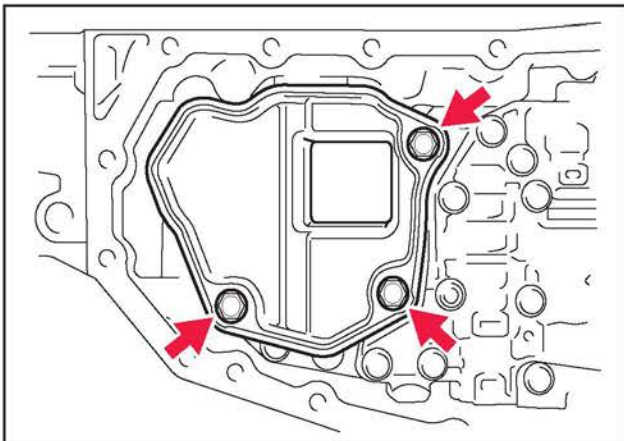

31. Remove the oil strainer and o-ring.
Discard both the strainer and o-ring.

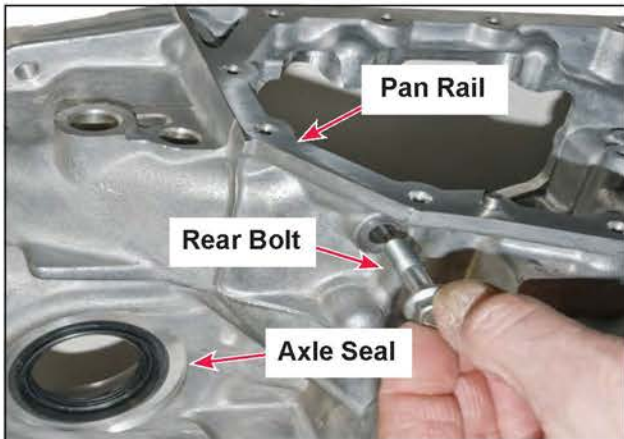

32. Remove the one oil pump mounting bolt from the rear of the transaxle case.
Remove and discard the o-ring.

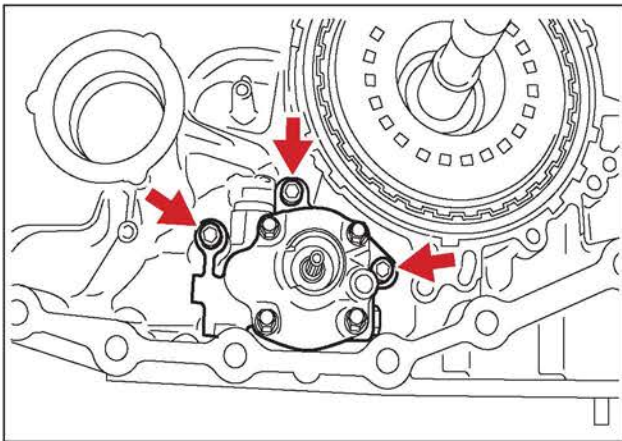

33. Remove the three allen head oil pump mounting bolts.

Remove the oil pump from the transaxle.

CAUTION

DO NOT remove the four hex head bolts from the oil pump assembly, this will cause damage to the oil pump.

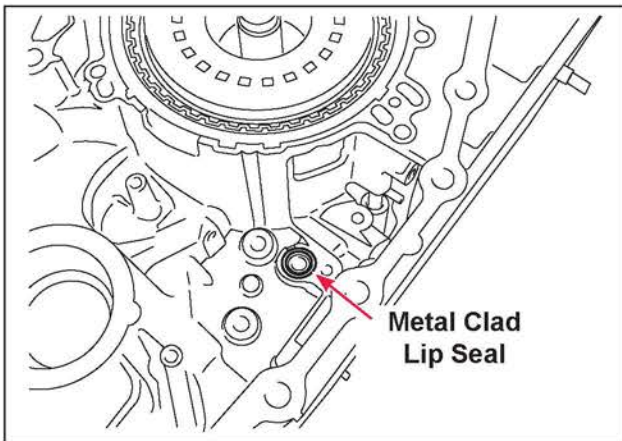

34. Remove and discard the metal clad lip seal from the transaxle case.

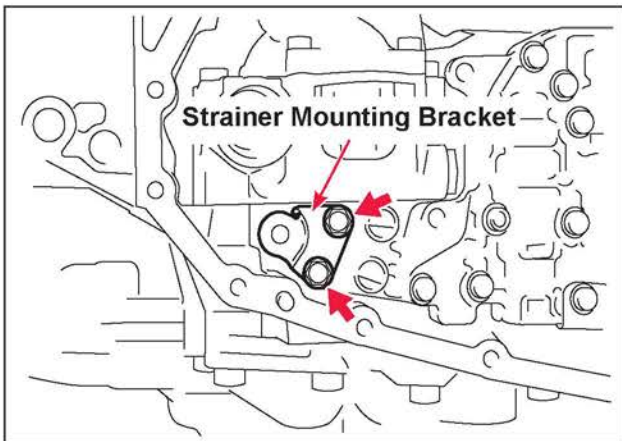

35. Remove the oil strainer mounting bracket from the valve body.

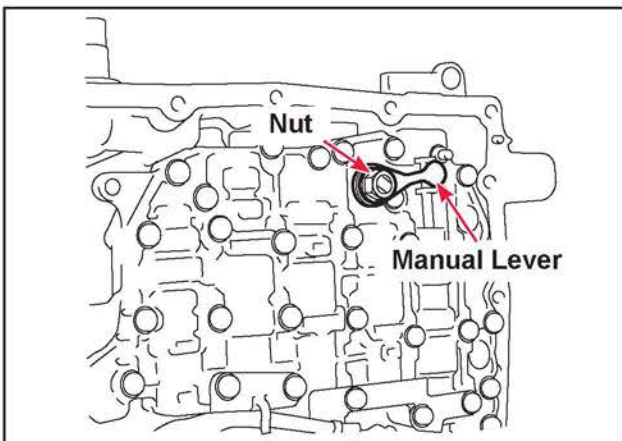

36. Remove the nut and lock washer from the manual control shaft.

Remove the manual valve control lever.

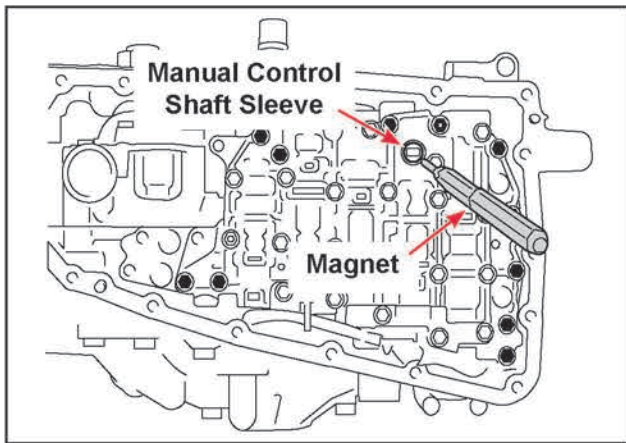

37. Using a magnet, remove the manual control shaft sleeve from the valve body.

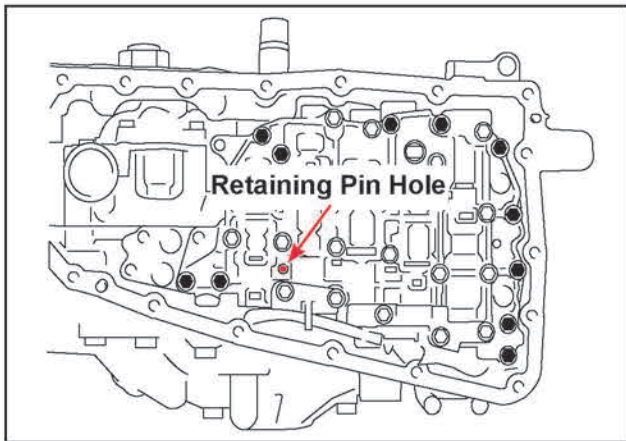

38. Insert a 0.120" (3 mm) diameter, 5.0" (126 mm) long pin into the retaining pin hole in the valve body.

NOTE: Cut a 5.0 in. piece out of an old coat hanger or use special tool MB995015-01.

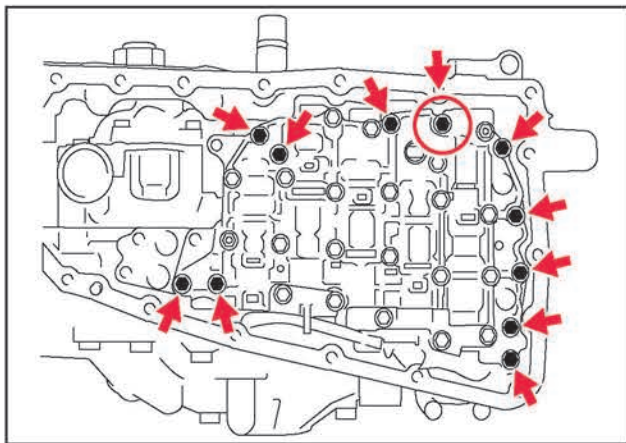

39. Remove the one short valve body bolt indicated by the circle, then remove the remaining ten long valve body mounting bolts.

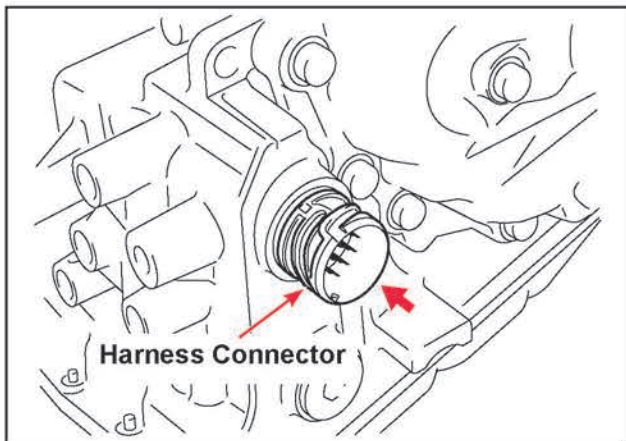

40. Remove the valve body by carefully sliding it back off of the manual control shaft while pushing the harness connector into the transaxle case.

SIDE COVER DISASSEMBLY

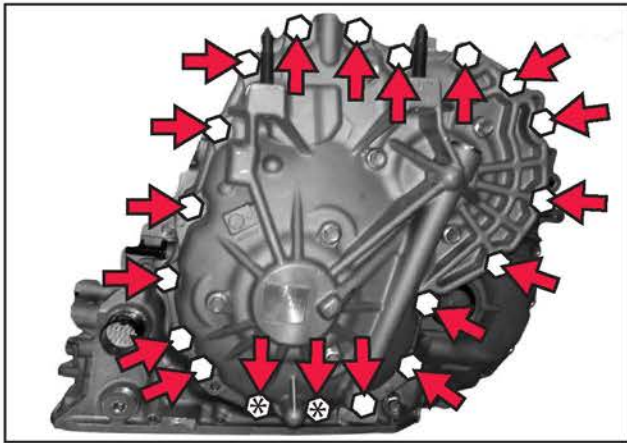

41. Remove 19 case bolts as shown by the arrows.

Note the 2 bolts marked with * in the picture are 5mm longer than the remaining 17 bolts.

17 bolts - 30mm long
2 bolts - 35mm long

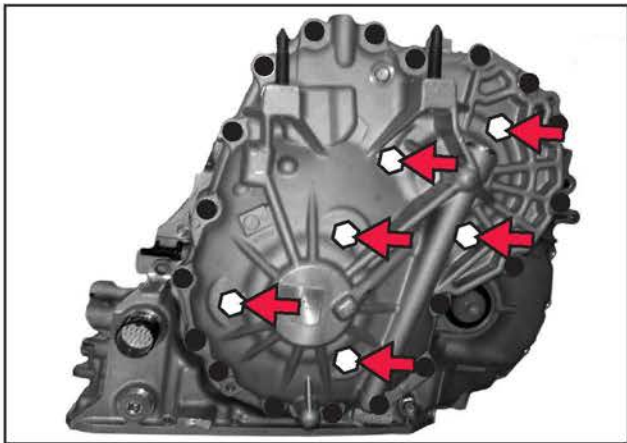

42. Remove the 6 bearing retainer bolts from the side cover as indicated by the arrows.

Rotate the transaxle onto the side cover (converter housing pointing up) and level the assembly with wood blocks.

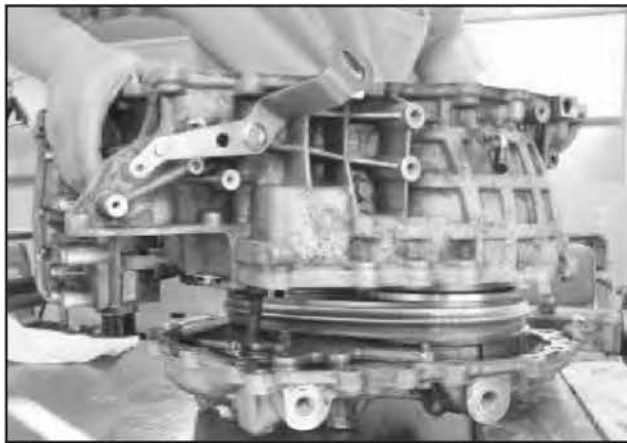

43. Separate the transaxle case from the side cover to expose the pulley assemblies.

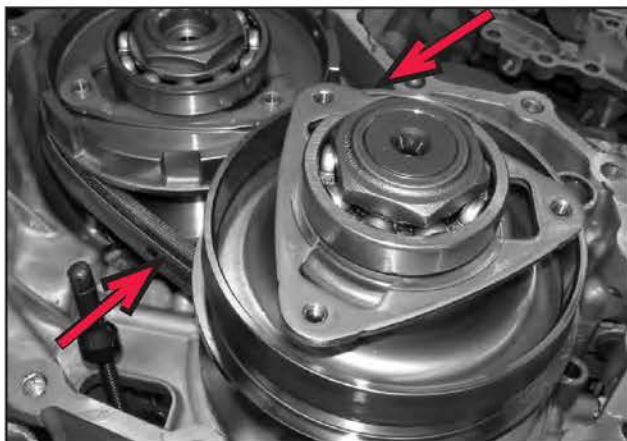

44. Keep the drive belt from separating during further disassembly by securely attaching two tie-wraps around the belt at the locations shown by the arrows.



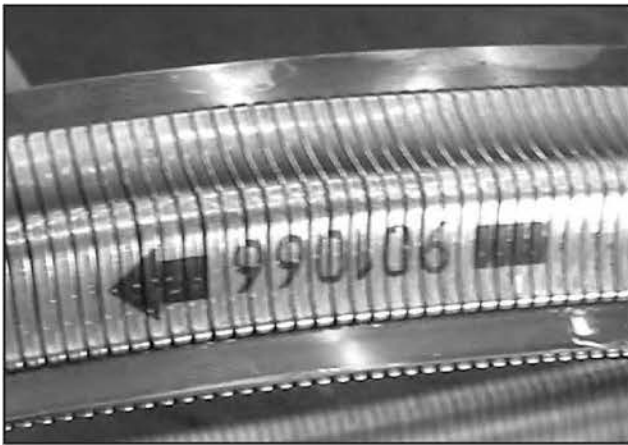

45. Note of the direction arrow marked on the belt.

On reassembly, the belt **MUST** be reinstalled with the arrow pointing in the same direction as it was removed.

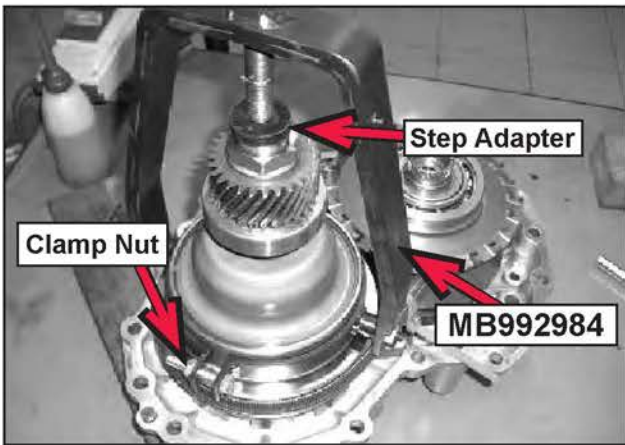

46. Place a 1.375" step adapter on the shaft.

Attach piston compressor (MB992984) to the secondary pulley and tighten the clamp nut securely. Make certain the compressor does not slide on the pulley housing.

NOTE: This tool compresses the pulley's internal spring, expanding the pulley width allowing belt to be removed.

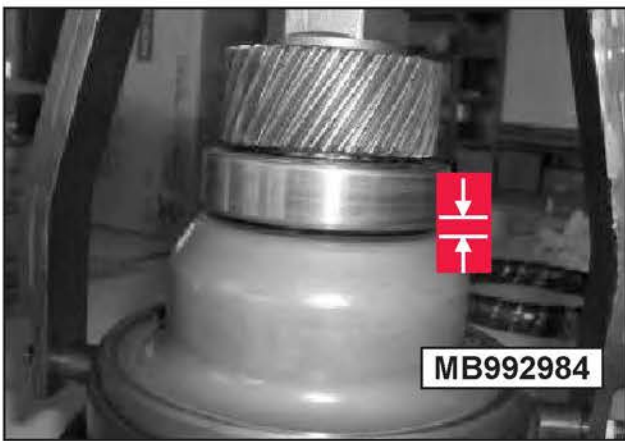

47. Turn the forcing screw clockwise. **STOP** turning when 3mm is measured at the location shown.

CAUTION

Overtightening the forcing screw will damage the secondary return spring.



48. To prevent damaging the belt during further steps, wind 28" protective tubing (MIT18594) around its entire length.

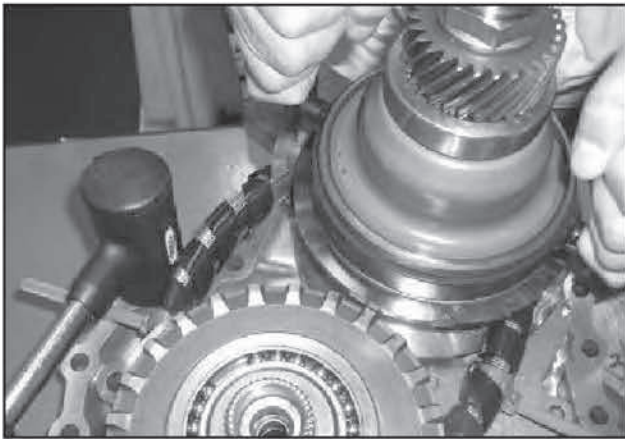

49. Firmly grasp the compressor with both hands and lift the secondary pulley assembly from the side cover.

This step may require the assistance of another technician to strike the case with a dead blow mallet to dislodge the bearing from the side cover.

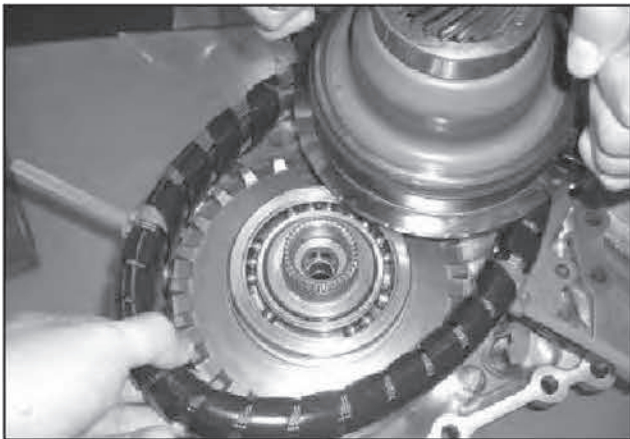

50. Once the bearing is free from the side cover, move the secondary pulley assembly toward the primary pulley. The added slack in the belt will enable another technician to slide the belt up and over the primary pulley as shown here.

51. Once the secondary pulley is removed, lift the primary pulley from the side cover.

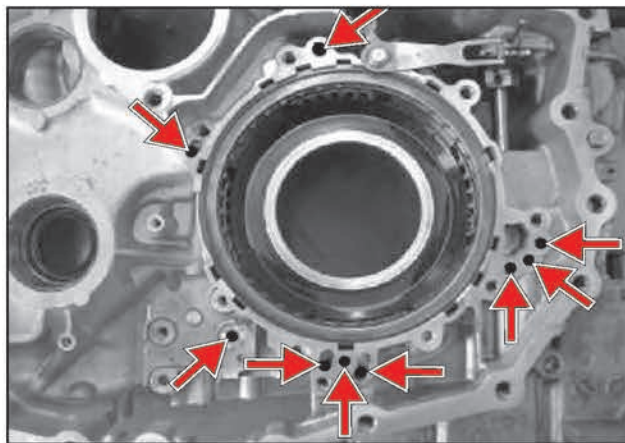

CLEANING

52. **While wearing eye protection**, use a non-chlorinated aerosol cleaner to flush each fluid passage indicated by the arrows.

Immediately follow with compressed air to remove any debris and cleaner residue.

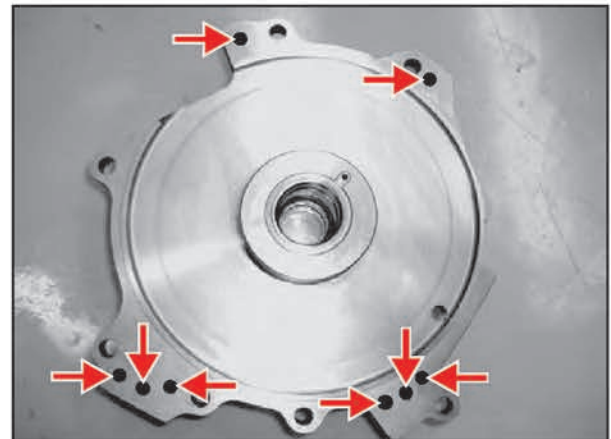
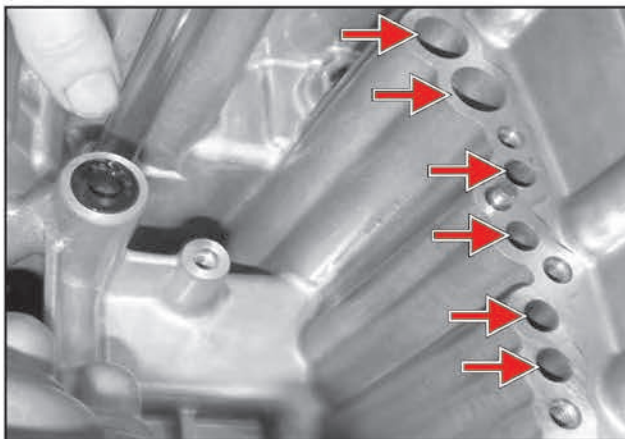

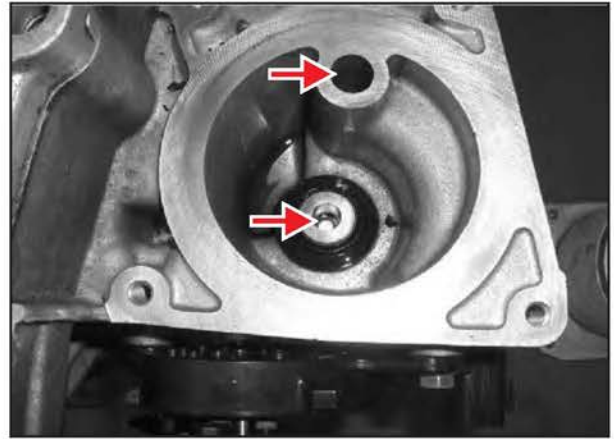
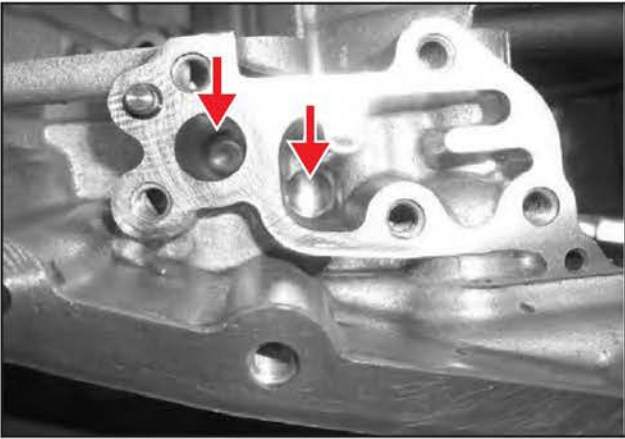
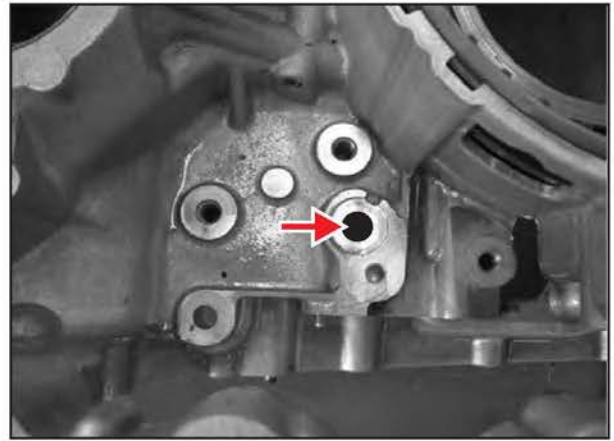
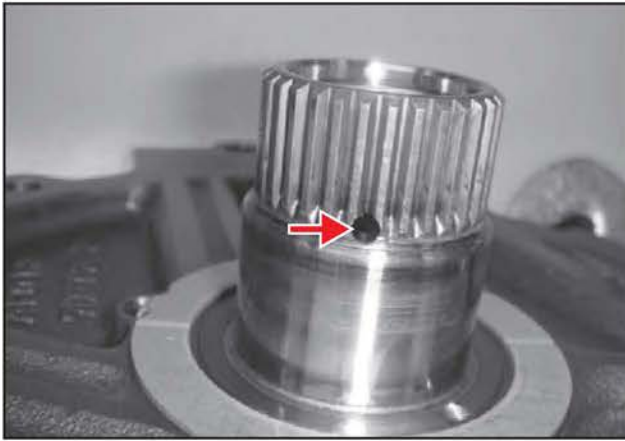

53. Remove all residual liquid gasket sealer from these mating surfaces:

- Converter Housing to Transaxle Case
- Transaxle Case to Side Cover

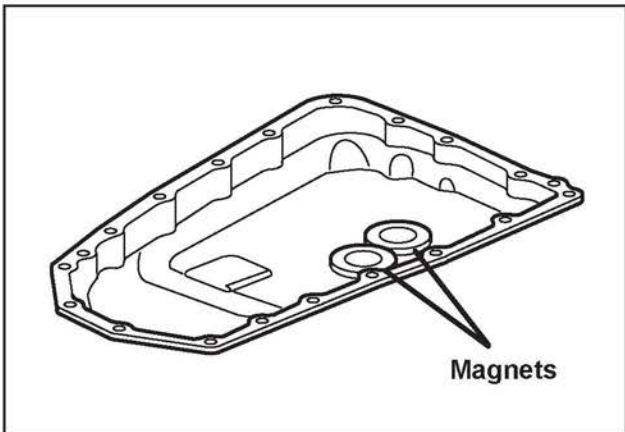

54. Thoroughly clean the transaxle pan and magnets.

CASE SEALS and O-RINGS

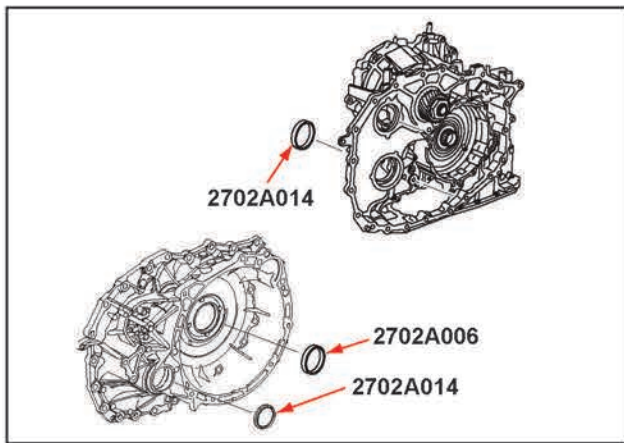

55. Before proceeding further, replace the converter housing seal and axle shaft seals. If necessary, consult service manual Group 23B for procedures and special tools.

Converter Housing Seal: 2702A006
Axle Seals: 2702A014

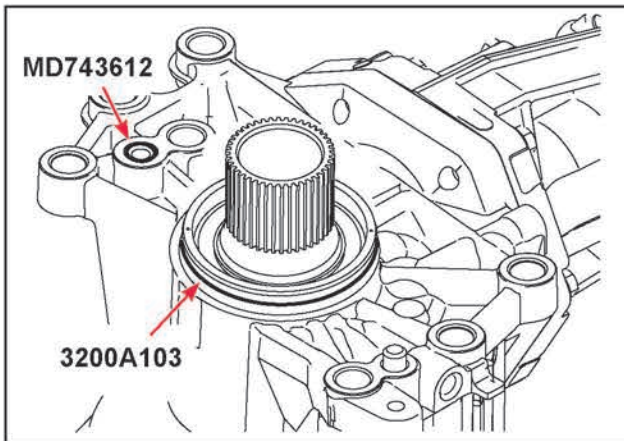

56. If the vehicle is equipped with AWD, replace the transfer case o-rings as shown here.

Apply petroleum jelly to the recess in the case where the small o-ring sits, then install the new o-ring (MD743612) into the recess.

BEARING REPLACEMENT



57. Press the primary pulley's front bearing from the shaft using special tools MD998917-01 and MB991448-01 as shown. Discard the bearing.

NOTE: Ensure the bearing splitter's jaws are fully seated under the bearing outer race. Do not use the bearing's C-ring groove to perform this step.



58. Ensure all surfaces are free of debris. Use special tool MB991389-01 or MLR-C-4660-A to press the new bearing (2950A049) onto the primary pulley shaft.

Ensure the bearing's C-ring groove faces the pulley flange as indicated by the arrow.

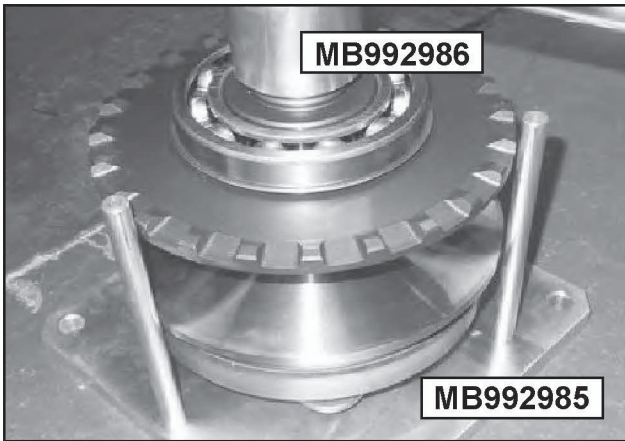

59. Clamp the holding fixture (MB992985) to the workbench. Place the primary pulley assembly (lock nut down) into the 50mm hexagonal opening in the fixture as shown.

Place the primary pulley holder (MB992986) onto the splines. Using a breaker bar, loosen the lock nut.

Turn the assembly over, remove the lock nut and discard it.



60. Use a common 3-jaw puller (e.g. OTC-1023) to remove the primary pulley's rear bearing. Discard the bearing and bearing retainer.

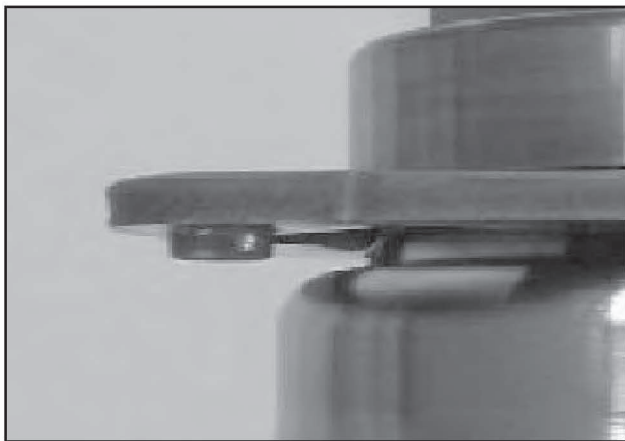

61. Clean all surfaces of any debris. Position the new bearing retainer (2771A001) as shown here.

Do not install the retainer upside down.

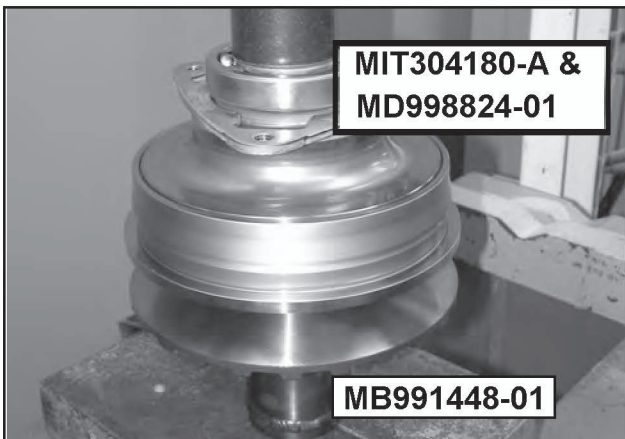

62. Set a new primary pulley bearing (2950A047) in place.

Using special tool MB991448-01 to support the assembly on the press table, seat the new bearing onto the primary pulley shaft with MIT304180-A and MD998214-01.



63. Thread the new 50mm lock nut (2771A004) in place.

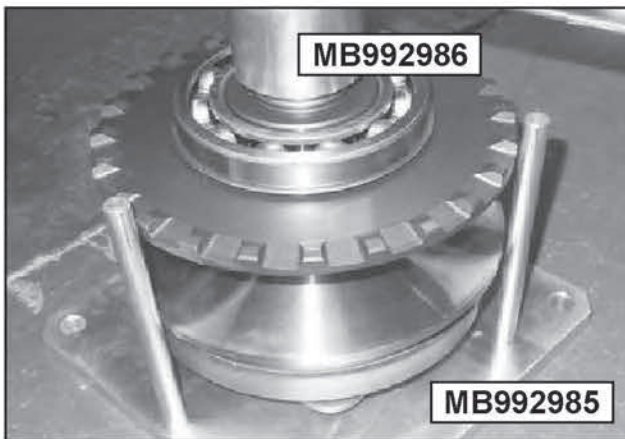

64. Insert the assembly into the holding fixture (MB992985).

Use the primary pulley holder (splined socket) (MB992986) to tighten the 50mm lock nut to 130Nm (96 ft-lbs.).



65. Position the secondary pulley assembly (lock nut down) in the holding fixture (MB992985) as shown.

Use a 40mm socket and breaker bar on the staked nut to loosen the 50mm lock nut being held by the fixture

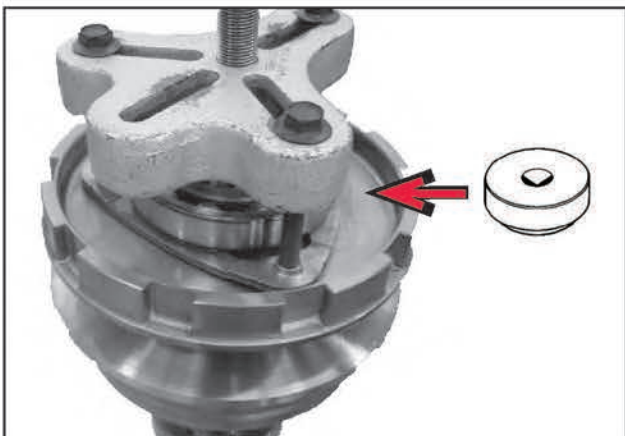

66. Before attaching a flange puller, place the press button (from MB992984) onto the shaft.

Use three 8mm x 1.25mm screws to attach the puller to the bearing retainer. Turn the forcing screw against the press button to remove the secondary pulley's front bearing.

Discard the bearing and bearing retainer.

Retainer may be deformed during this step.



67. Position the new bearing retainer (2771A002) and new bearing (2950A048) onto the secondary shaft as shown here.

Do not install the bearing retainer upside down.



68. Support the output gear on the press table using special tools MIT304180-A and MD998829-01.

Use a 40mm socket to press the bearing onto the secondary pulley shaft.



69. Thread a new 50mm lock nut (2771A003) onto the shaft and return the secondary pulley assembly to the holding fixture (MB992985) as shown.

Use a 40mm socket and torque wrench on the staked nut to tighten the new lock nut (held by the holding fixture) to 310Nm (228 ft-lbs.).

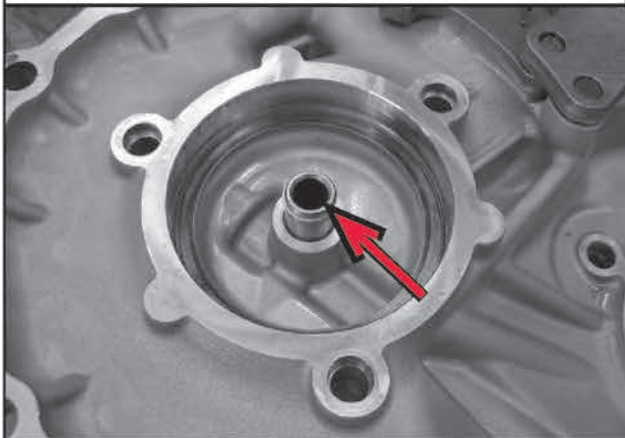

70. Install a new sealing ring (2931A005) as shown here.

NOTE: There may be 2 sealing rings depending upon design. If so, replace both.



71. To make component installation easier, level the side cover with wood block(s).



72. Install the primary pulley into the side cover.



73. With slight downward pressure, shake the primary pulley assembly until the bearing is fully seated in the side cover.

Check the installed position by measuring the dimension as shown.

The pulley flange should protrude above the side cover mating surface by 1.5mm to 2.0mm (0.059" to 0.078").

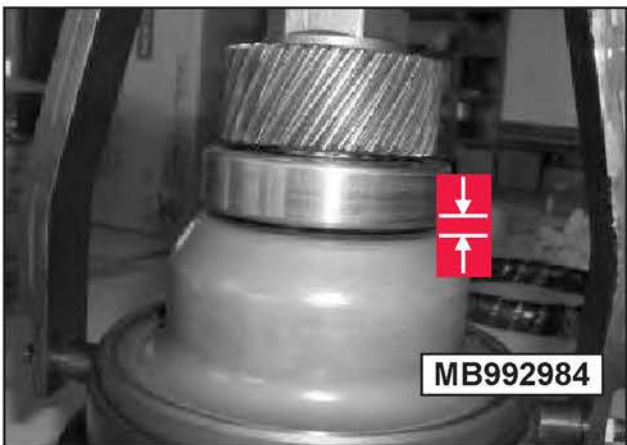

74. Attach the compressor (MB992984) over secondary pulley as shown in Step 39. Turn the forcing screw clockwise. **STOP** turning when 3mm (.118") is measured at the location shown.

⚠ CAUTION

Overtightening the forcing screw will damage the secondary return spring.



75. Install the belt around the secondary pulley. Note the directional arrow.

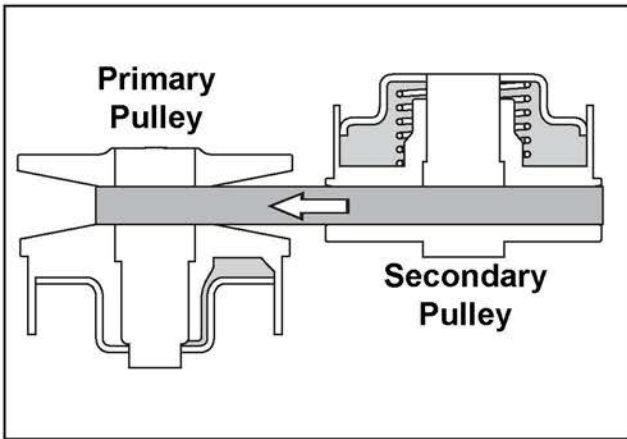
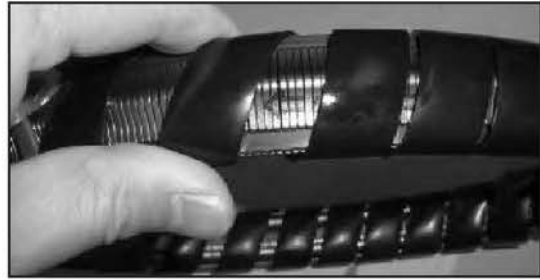

76. Verify the arrow's direction matches the drawing shown here.

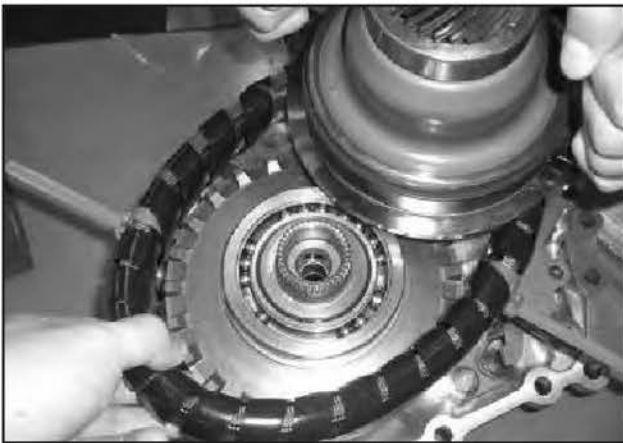

77. Hold the compressor close to the primary pulley while another technician slides the belt into the primary pulley groove.

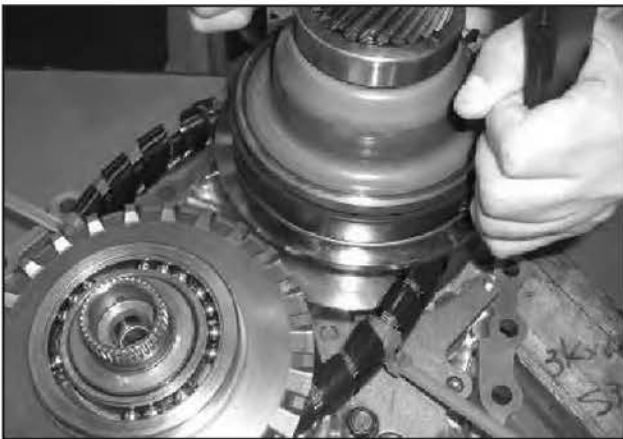

78. Once the belt is in position, install the secondary pulley assembly into the side cover.

Like the primary pulley installation, shake the assembly until the bearing is seated.



79. The pulley flange should stand 12mm (.472") above the side cover when the bearing is fully seated.

Once the secondary pulley assembly is fully seated, remove the compressor (MB992985).

Remove the protective convolute tubing and tie-wraps from the belt.

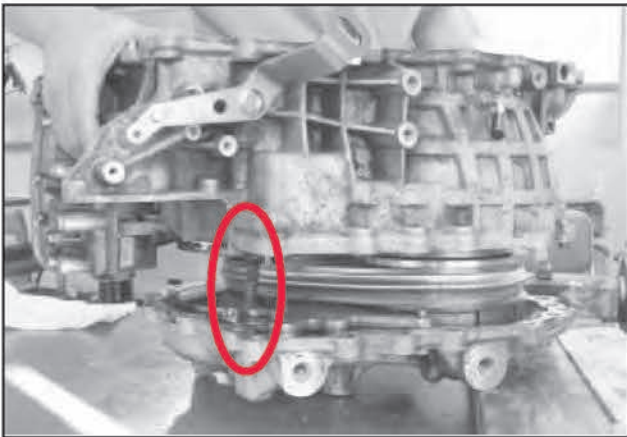

80. Shift to PARK position. Align the park rod into position, shown by the arrow, and lower the converter housing onto the side cover.

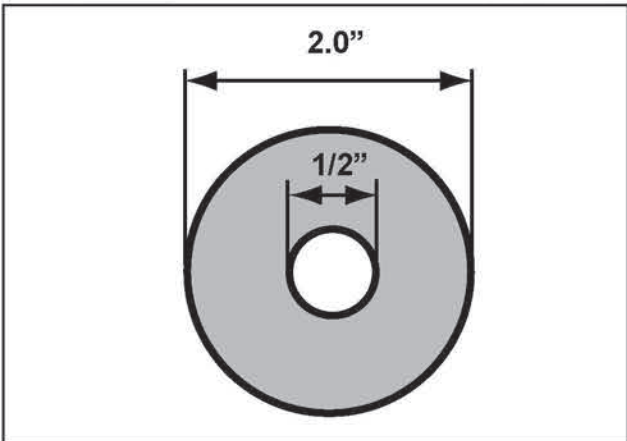
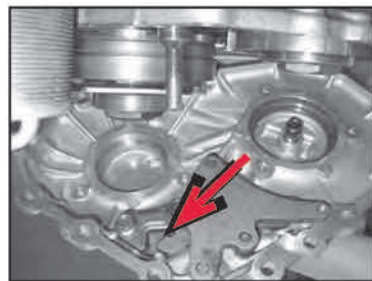

81. To hold the secondary pulley assembly stationary in the side cover as the transaxle is flipped over in step 83, use a 2" x 1/2" fender washer.

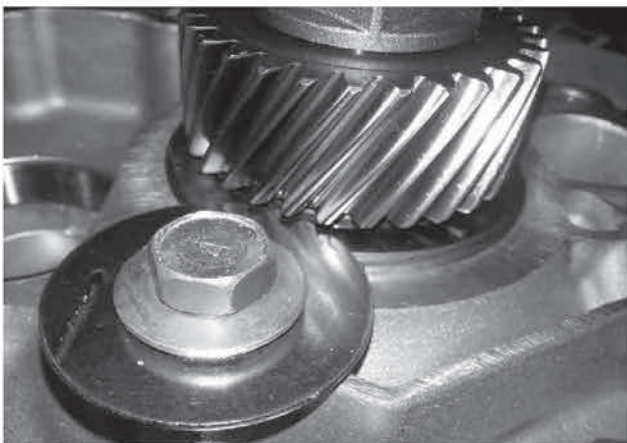

82. Insert fender washer into the space between the output gear and the bearing.

Use flat washers underneath the fender washer to level it.

Secure with a bolt, finger tight only .

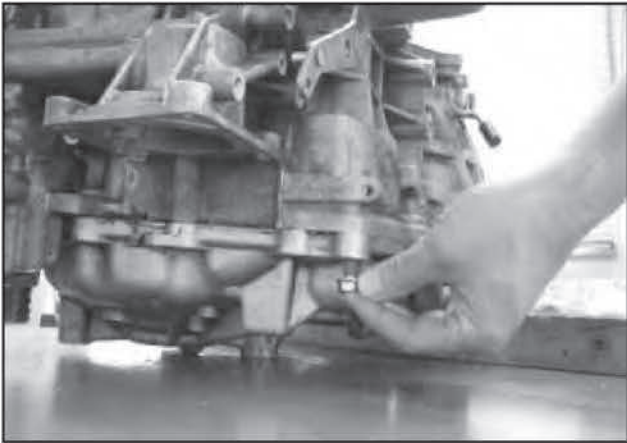

83. Install two bolts to hold the transaxle case and side cover together temporarily.

Turn the transaxle over and position on wood blocks with the side cover facing up. Verify the output gear clears the workbench.

Remove the two bolts and remove the side cover.

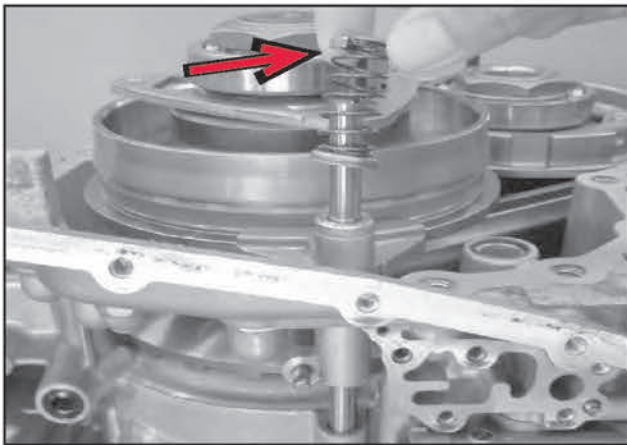

84. Install the primary pulley sensor. Note the spring installation direction as shown by the arrow.



85. Install the manual shaft locating pin.

Remove the fuel hose installed in step 23.

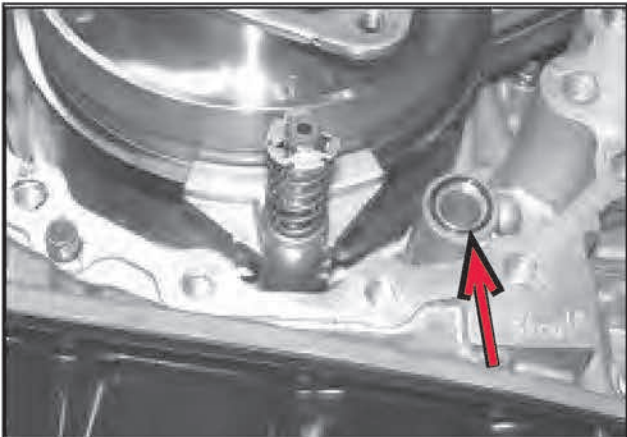

86. Install new o-ring (2702A078) as shown.

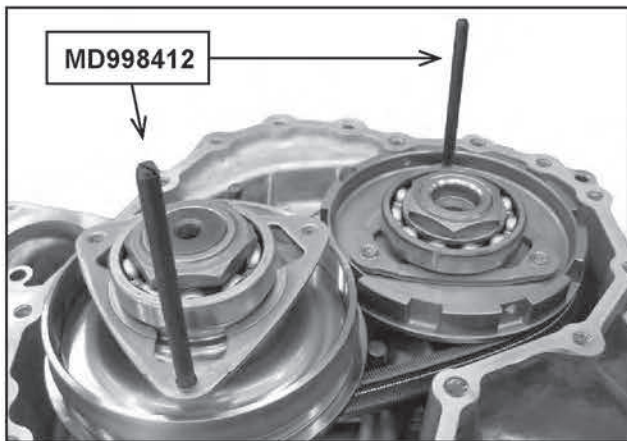

87. To simplify aligning the bearing retainers with the side cover bolt holes, loosely install guide pins (MD998412) as shown.

NOTE: As the guide pin threads are different than the retainer's threads, do not tighten the guide pins.

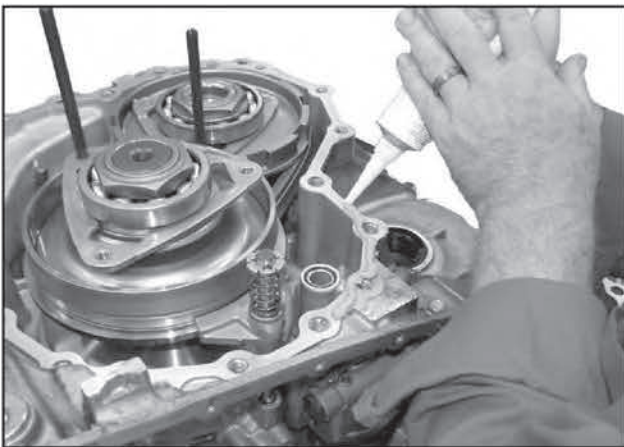

88. Apply a 1.5mm (0.060") bead of Loctite 509 (or equivalent) to the mating surface of the side cover.

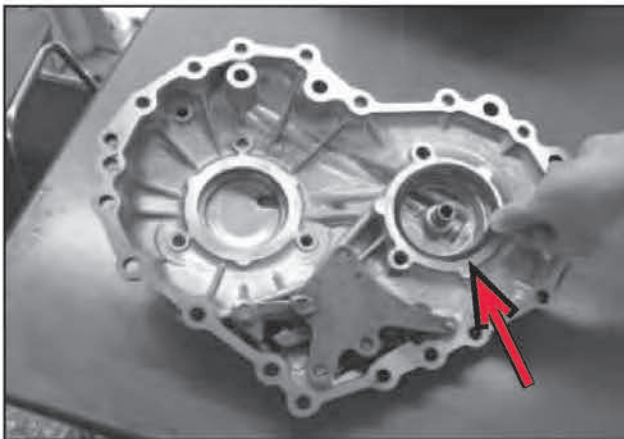

89. Install the secondary pulley side cover shim.

Because the side cover will be turned over in the next step, use petroleum jelly to keep the shim in place.

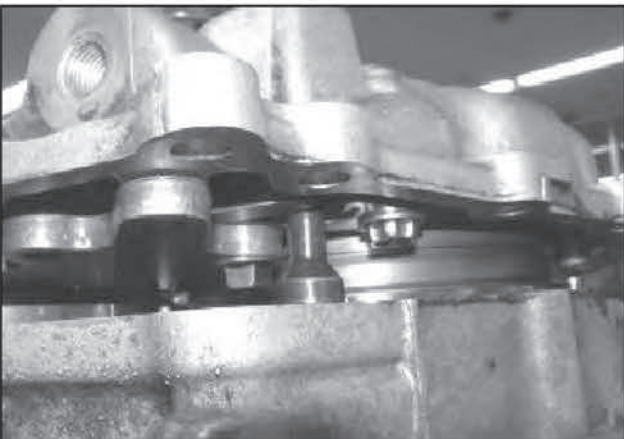

90. Verify the shift linkage is in PARK. Lower the side cover onto the transaxle case using the guide pins (MD998412) to position the bearing retainers with their bolt holes.

Take care to guide the park rod and speed sensor into their locations in the side cover.

When properly aligned, seat the converter housing to the side cover with a deadblow mallet.

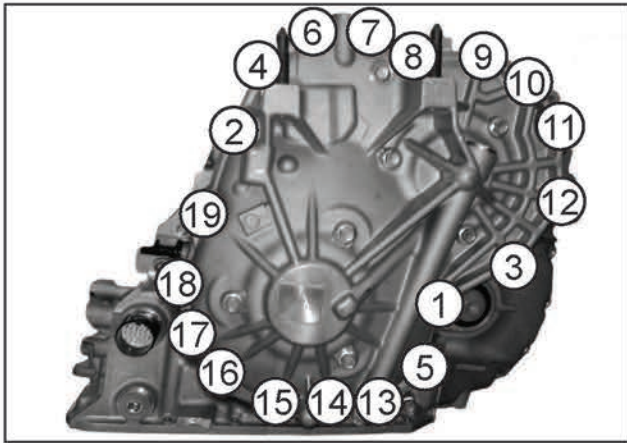

91. Install the 19 case bolts and tighten to 45Nm (33 ft-lbs.) in the numbered sequence shown.

Make certain to install the two longer 35mm bolts at locations 14 and 15.



92. Install new o-rings (2791A012) on the six bearing retainer bolts.

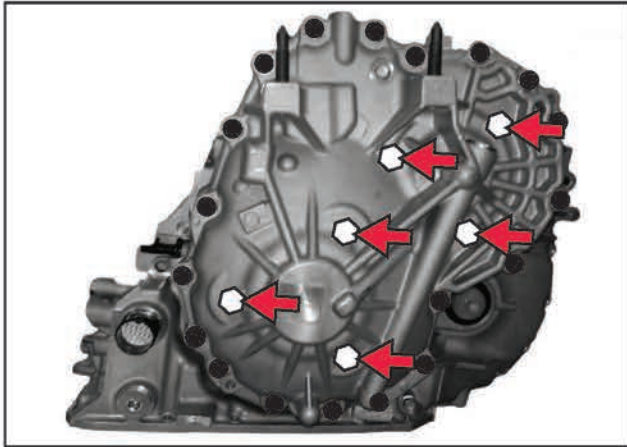

93. After verifying the bearing retainers are properly aligned, thread one bolt into each retainer to maintain their positions.

Remove the guide pins.

Install the remaining bolts and tighten to 28Nm (21 ft-lbs.).

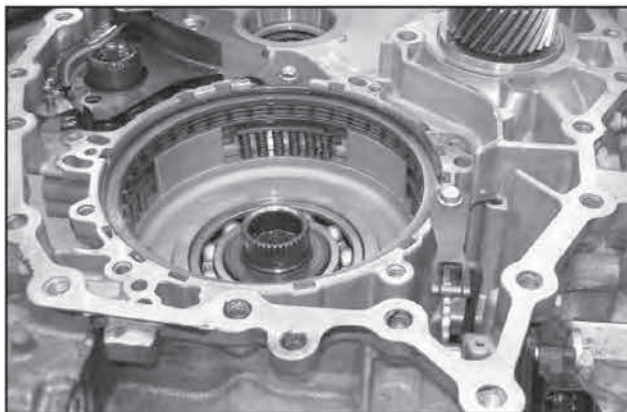

REASSEMBLY PROCEDURES

94. Turn the transaxle over on the workbench as shown, supporting the side cover with blocks.

Installed in step 81, remove the fender washer from under the output gear.

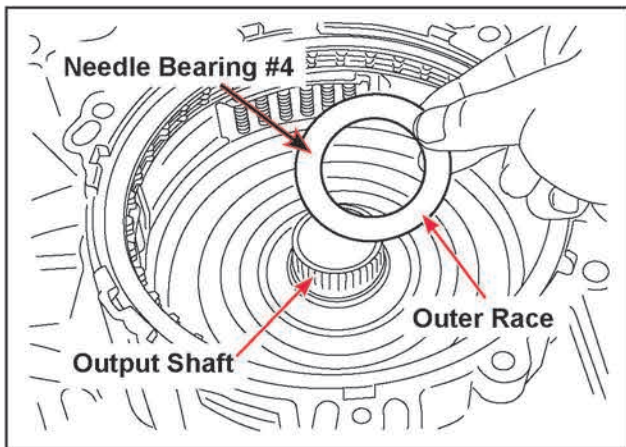

95. Install the needle bearing assembly #4 located between the output shaft and planet carrier with the **OUTER** bearing race facing upward, over top of the primary pulley drive splines.

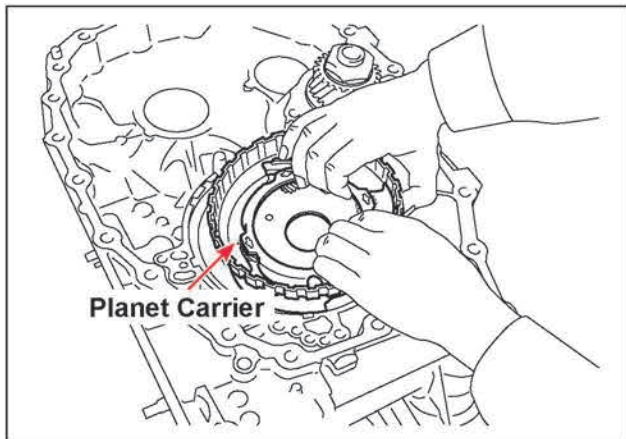

96. Install the planet carrier into the transaxle case. Rotate the planet carrier back and forth to make sure all clutch friction discs are engaged with the hub. Continue until the planet carrier is sitting down against the needle thrust bearing.

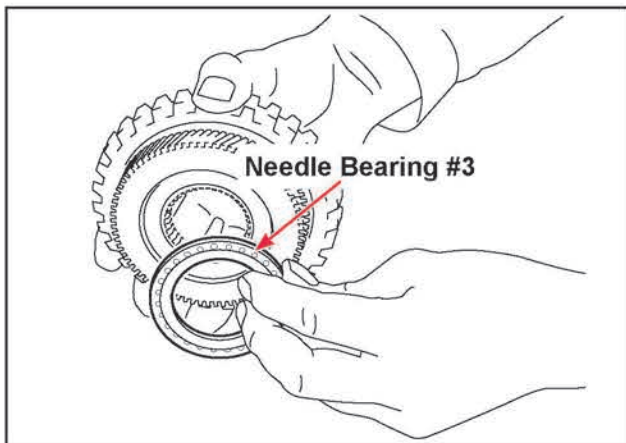

97. Install the needle bearing assembly #3 located between the planet carrier and the sun gear using petroleum jelly to hold it onto the bottom side of the sun gear with its **OUTER** race facing the sun gear.

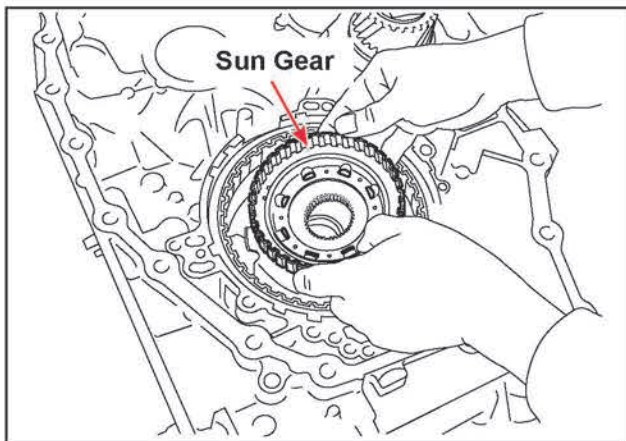

98. Install the sun gear down into the planet carrier, rotate it back and forth until it seats on top of the needle bearing.

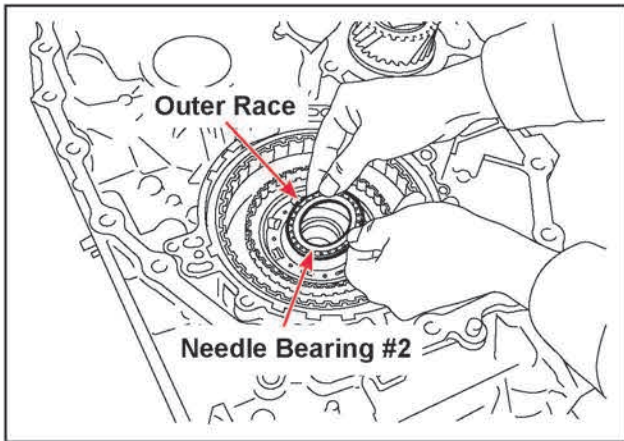

99. Install the needle bearing assembly #2 between the sun gear and forward clutch drum down into the top side of the sun gear with the **OUTER** race facing downward toward the sun gear.

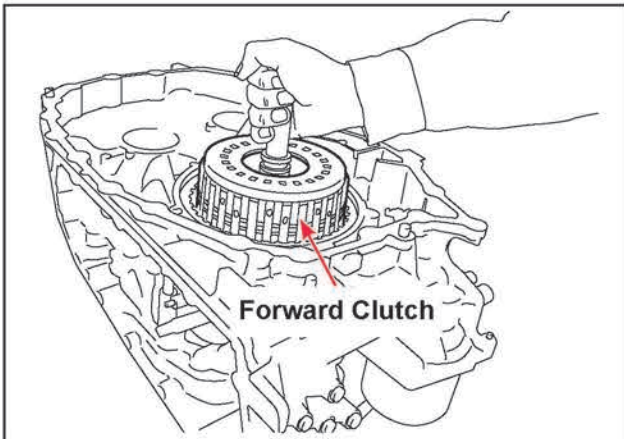

100. Apply a coating of petroleum jelly to the sealing rings and bushing surface on the back of the input shaft.
101. Install the forward clutch assembly into the transaxle case. Rotate the assembly back and forth until it is drops down and is seated against the needle thrust bearing.

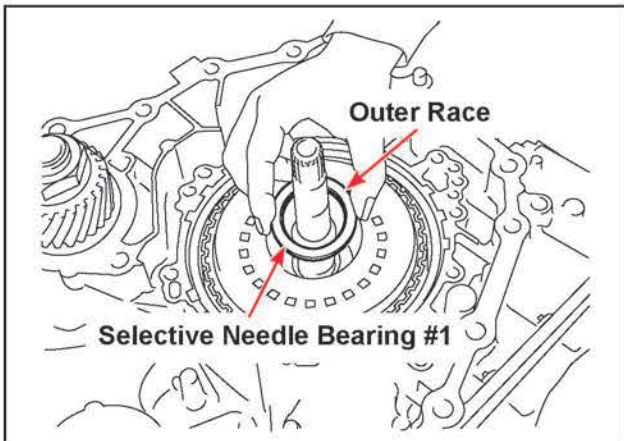

102. Install the selective needle bearing assembly #1 down into the forward clutch drum with the **OUTER** race facing up.

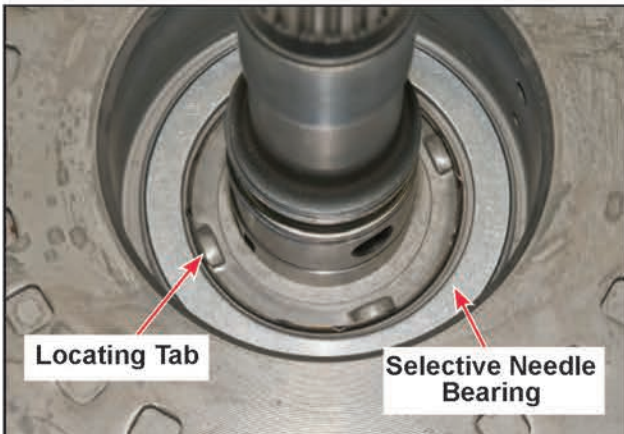

103. Verify the bearing is not sitting on top of any of the locating tabs on the forward clutch drum.

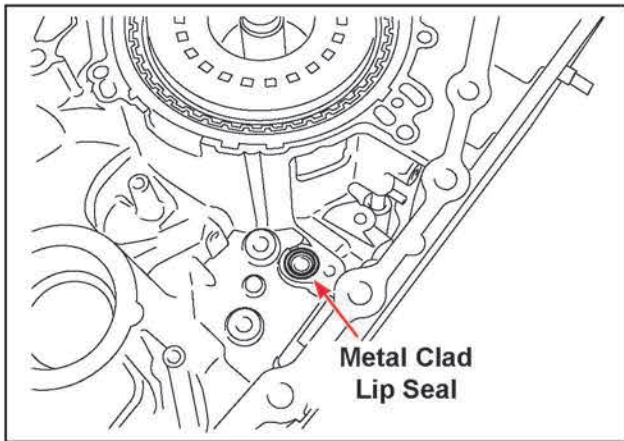

104. Install a new oil pump metal clad lip seal (2791A014) into the recess in the transaxle case using petroleum jelly to hold it in position.

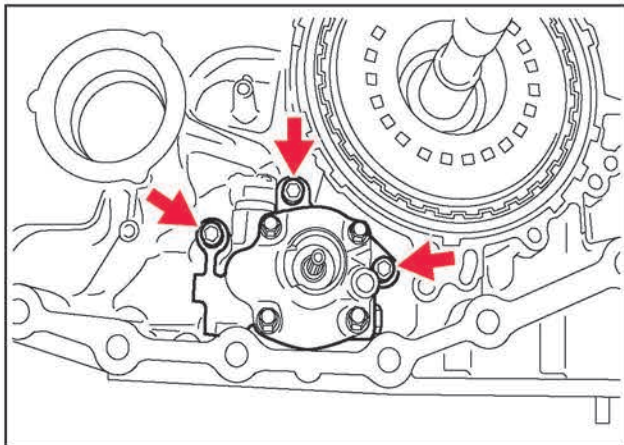

105. Lower the oil pump into the transaxle case.
Install the three allen head oil pump mounting bolts finger tight only at this time

3	Long Bolts	70 mm (2.75 in.)
---	------------	------------------

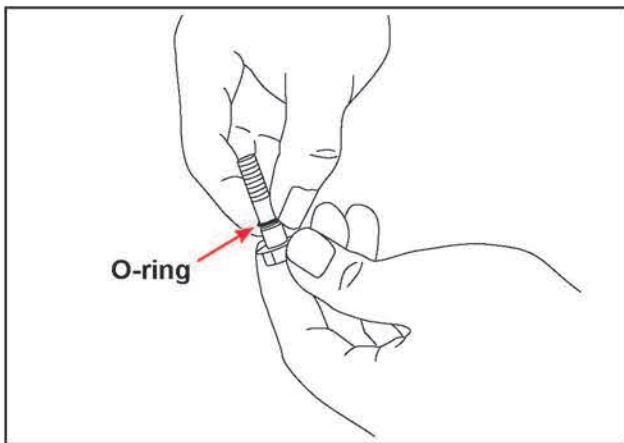

106. Install a new o-ring (2791A012) onto the rear pump mounting bolt. Then apply a coating of petroleum jelly to the o-ring.

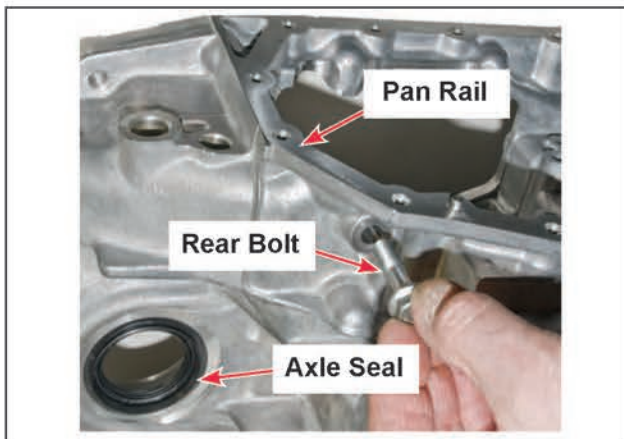

107. Install the rear oil pump mounting bolt into the back side of the transaxle case finger tight only at this time.
108. Tighten the three allen head oil pump mounting bolts to 19Nm (14 ft-lbs.)
Tighten the rear mounting bolt to 28Nm (21 ft-lbs.)

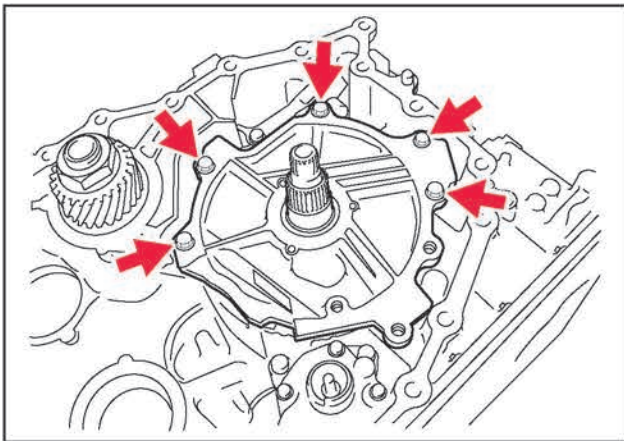

109. Apply a coating of petroleum jelly to the new sealing rings (2791A029) and bushing surfaces on the input shaft and pump cover (stator support).

110. Install the pump cover (stator support) and the five mounting bolts into the locations indicated, finger tight only at this time

5	Long Bolts	30 mm (1.18 in.)
---	------------	------------------

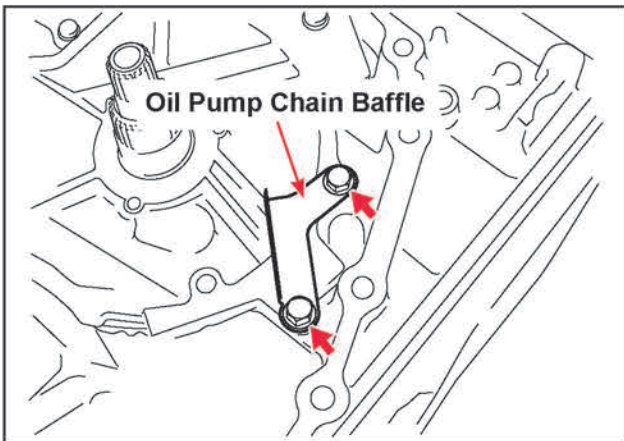

111. Install the oil pump chain baffle in the location shown using two mounting bolts.

Tighten all of the pump cover (stator support) and oil pump chain baffle mounting bolts to 19Nm (14 ft-lbs.)

2	Long Bolts	30 mm (1.18 in.)
---	------------	------------------

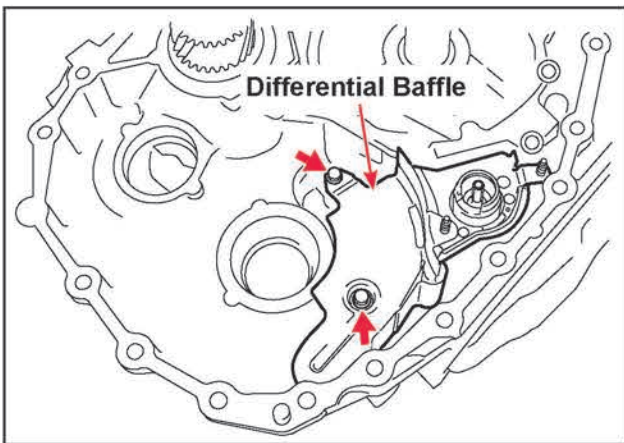

112. Install the differential baffle plate and the two mounting bolts.

Tighten the bolts to 5.8Nm (52 in-lbs.)

2	Short Bolts	16 mm (.630 in.)
---	-------------	------------------

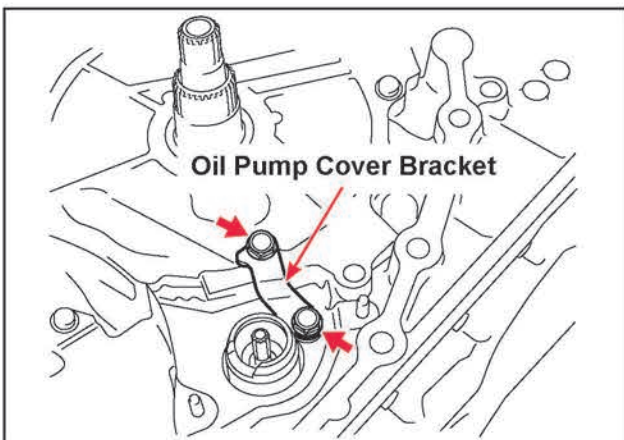

113. Install the oil pump bracket with the two bracket mounting bolts.

Tighten the bolts to 25Nm (19 ft-lbs.)

2	Short Bolts	16 mm (.630 in.)
---	-------------	------------------

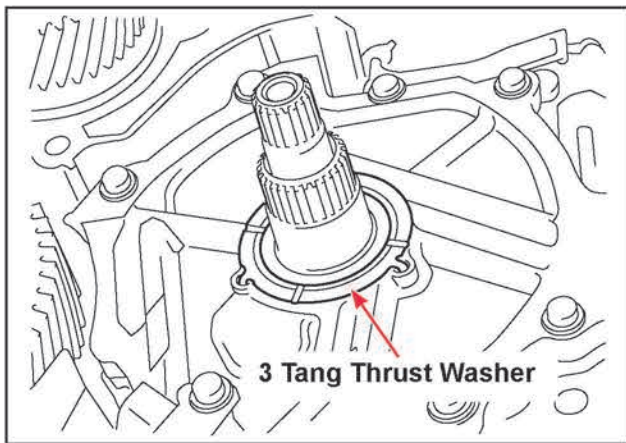

114. Install the three tang Thrust Washer on the pump cover (stator support) making sure the three tangs on the thrust washer are in the three holes in the pump cover (stator support).

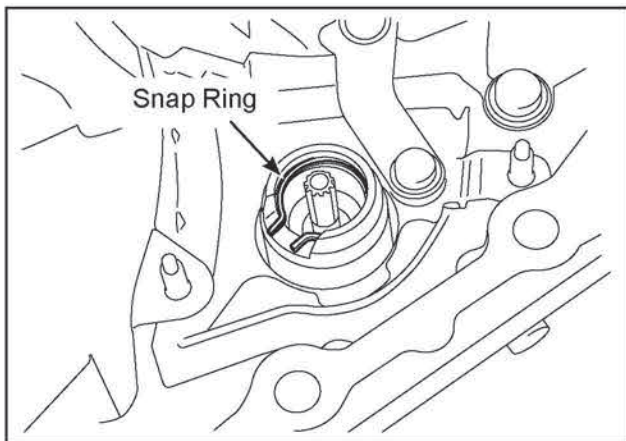

115. Install the new driven sprocket ball bearing retaining snap ring (2791A018) into the oil pump housing with the opening in the snap ring aligned with the cutout in the oil pump housing.

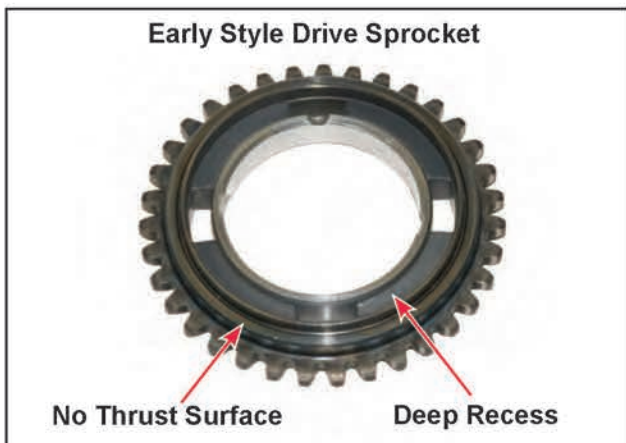

116. Set the drive sprocket on the bench with the **DEEP RECESS FACING UP**. Set the driven sprocket on the bench with the ball bearing **FACING DOWN**.

Wrap the new chain (2791A024) around the sprockets making sure the colored chain link is **FACING UP**.

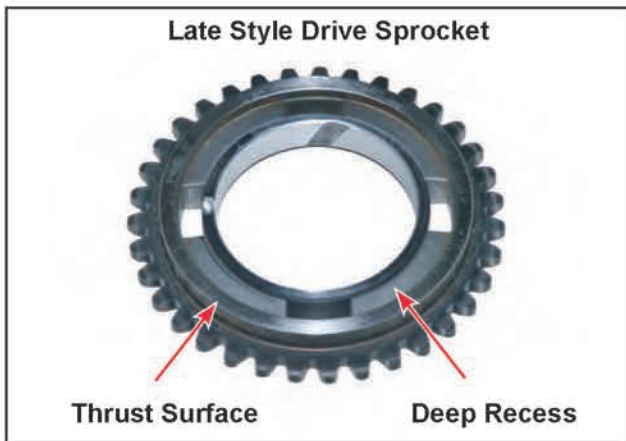

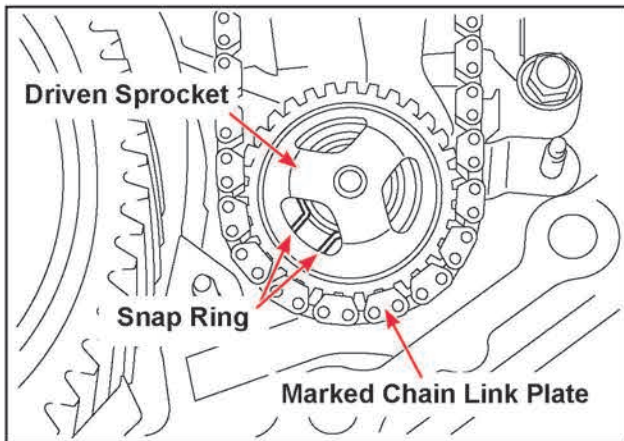

117. With the sprockets and chain as positioned in step 115, slide the assembly down over the shafts.

118. Rotate the oil pump driven sprocket until one of the three cutouts in the driven sprocket lines up with the opening in the snap ring.

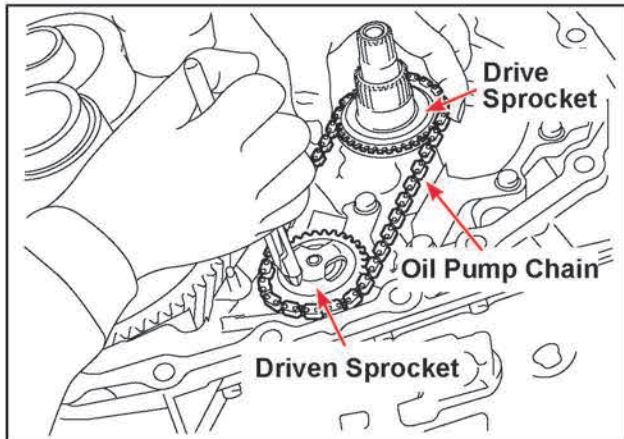

119. Using a pair of external snap ring pliers, expand the snap ring, at the same time slide both the drive and driven sprockets downward along with the chain until the drive sprocket fully seats on the three tang thrust washer.

120. While expanding the snap ring carefully move the oil pump driven sprocket up and down until the snap ring seats in the groove in the outer race of the ball bearing.

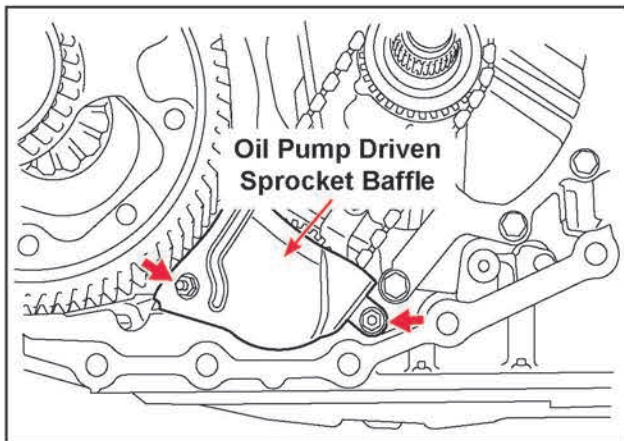

121. Install the oil pump driven sprocket baffle on the studs in the transaxle case.

Install the two 10mm mounting nuts and tighten to 5.8Nm (52 in-lbs.).

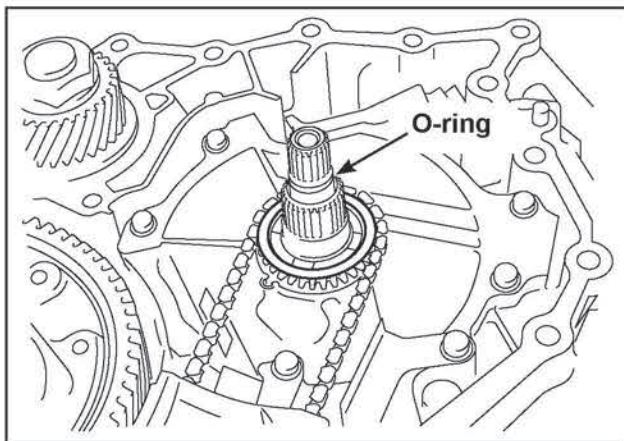

122. Install a new o-ring (2761A009) into the groove on the input shaft.

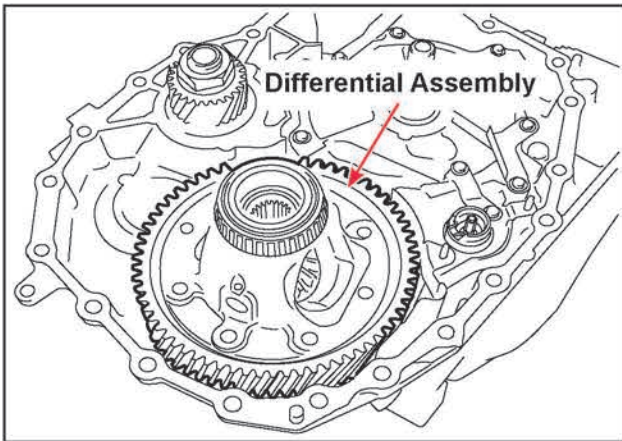

123. Install the differential assembly into the transaxle case.

If bearings were replaced, verify proper shim thickness using Service Manual selection procedures.

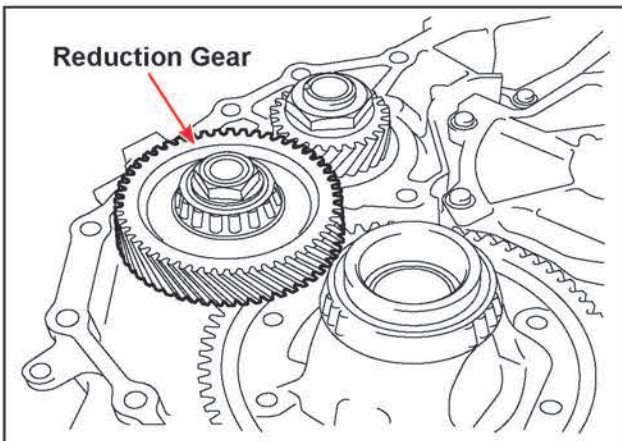

124. Install the reduction gear assembly into the transaxle case.

If bearings were replaced, verify proper shim thickness using Service Manual selection procedures.

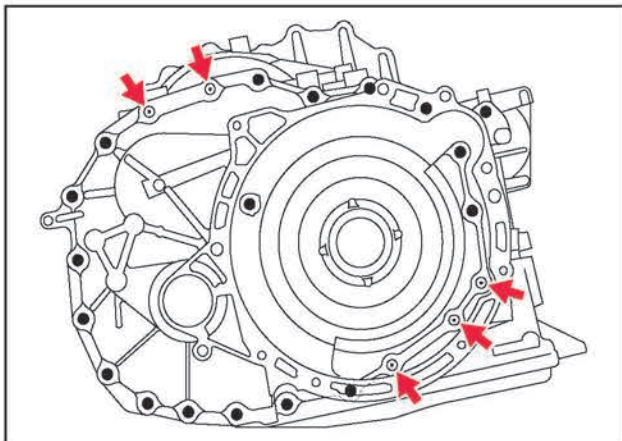

125. Place a 1.5mm (0.60") bead of Loctite 509 (or equivalent) on the transaxle case mating surface.

Install the converter housing onto the transaxle case, then install the five **LONG** converter housing mounting bolts identified by the **Dimple** located in the center of the hex head into the indicated locations.

5	Long Bolts	35 mm (1.38 in.)
---	------------	------------------

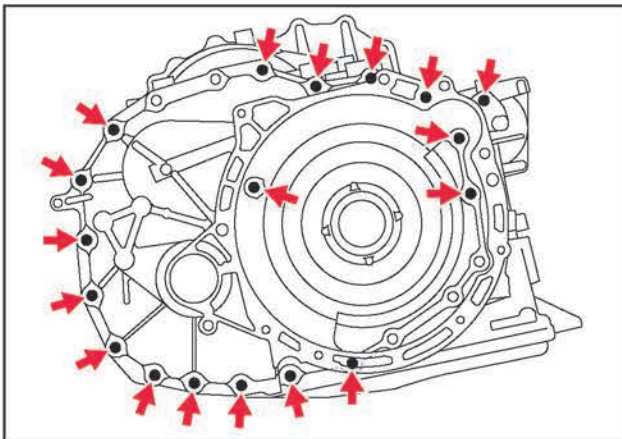

126. Install eighteen **SHORT** converter housing mounting bolts into the indicated locations.

Tighten all bolts to 45Nm (33 ft-lbs.)

18	Short Bolts	30 mm (1.18 in.)
----	-------------	------------------

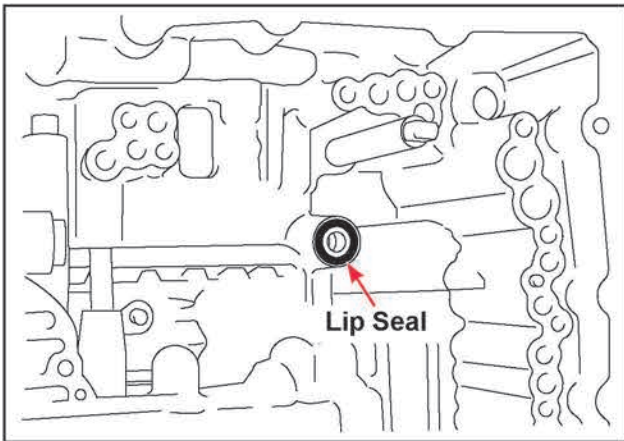

127. Apply petroleum jelly to the new reverse brake clutch passage lip seal (2800A031) and install it into the transaxle case.

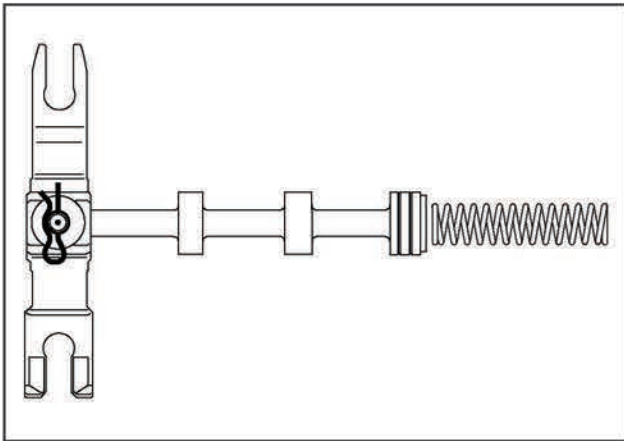

NOTE: If the ratio control valve and spring were to fall out of the valve body during the disassembly process, this drawing indicates the correct location of the spring.

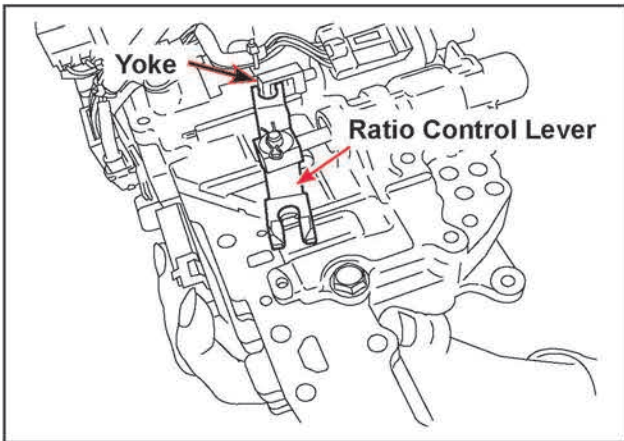

128. Position the ratio control valve lever so that it is engaged over the yoke on the stepper motor. Push the ratio control lever inward toward the valve body.

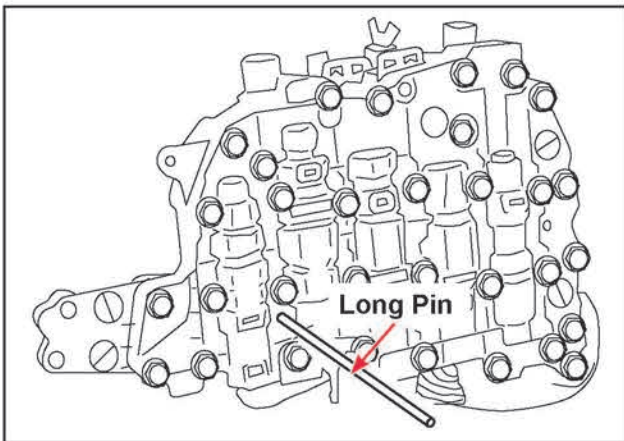

129. While holding the ratio control lever in, insert the long pin used in disassembly into the hole in the valve body.

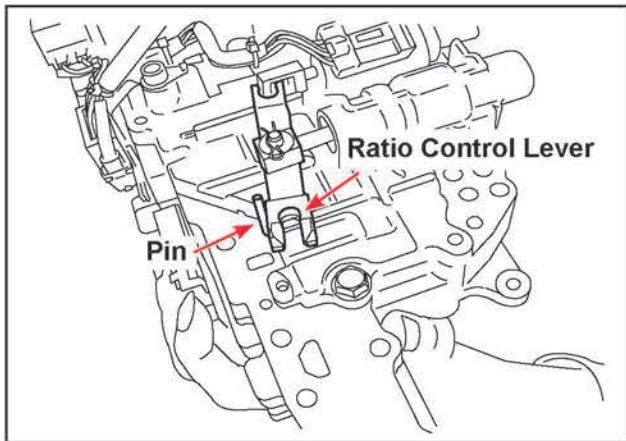

130. Verify the ratio control valve lever is securely positioned behind the pin.

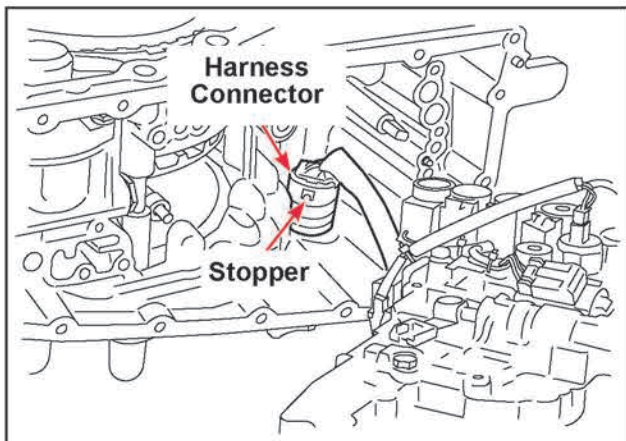

131. Install the harness connector into the transaxle case. Push the harness connector toward the outside of the transaxle case until the stopper is fully seated.

Be careful not to damage the o-ring.

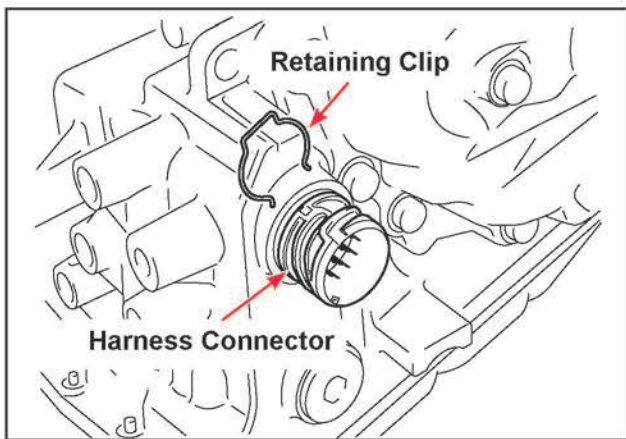

132. Install the retaining clip into the groove on the harness connector.

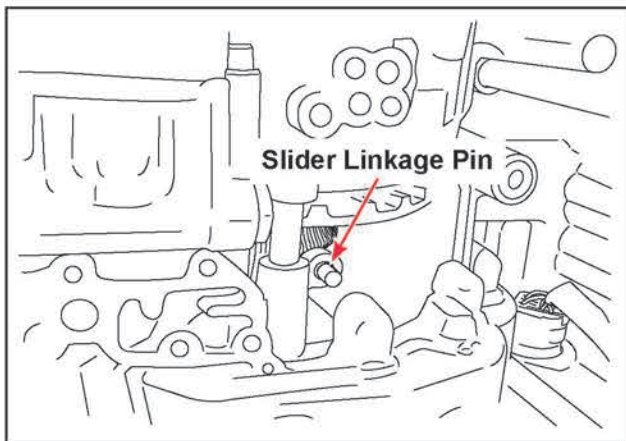

133. Locate the slider linkage pin. When installing the valve body, the cutout in the ratio control lever must engage with the slider linkage pin.

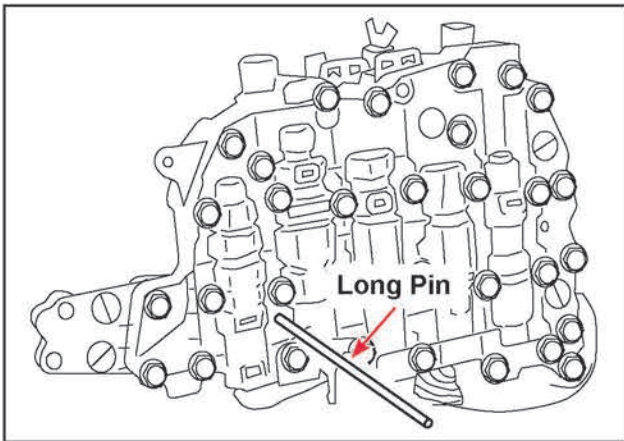

134. While holding the end of the long pin, install the valve body into the case making sure the ratio control valve linkage engages the pin on the slider linkage and that the valve body seats on to the dowel pins mounted in the transaxle case.

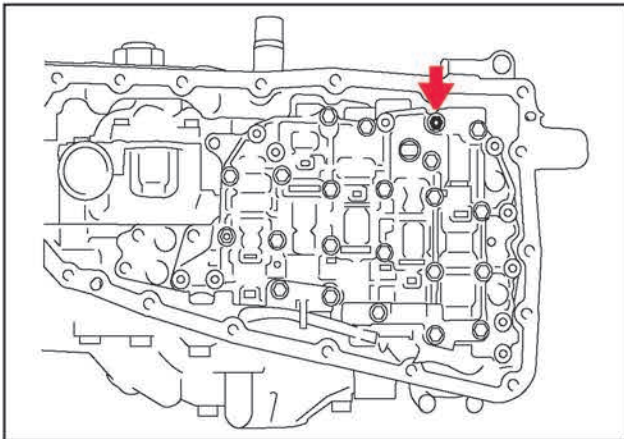

135. While holding the valve body against the transaxle case surface, install the one **SHORT** valve body mounting bolt into the location indicated and tighten it just enough to keep the valve body on the dowel pins.

1	Short Bolt	44 mm (1.73 in.)
---	------------	------------------

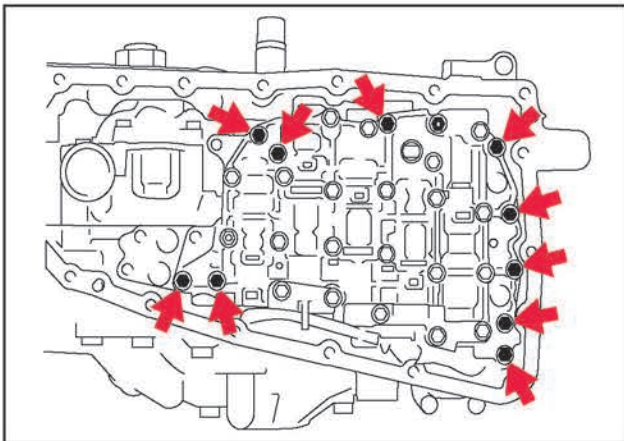

136. Install the remaining ten **LONG** valve body mounting bolts into the locations indicated finger tight only at this time.

10	Long Bolts	54 mm (2.13 in.)
----	------------	------------------

Remove the long pin (installed in step 128) from the valve body.

Tighten all valve body bolts to 7.9Nm (70 in-lbs.).

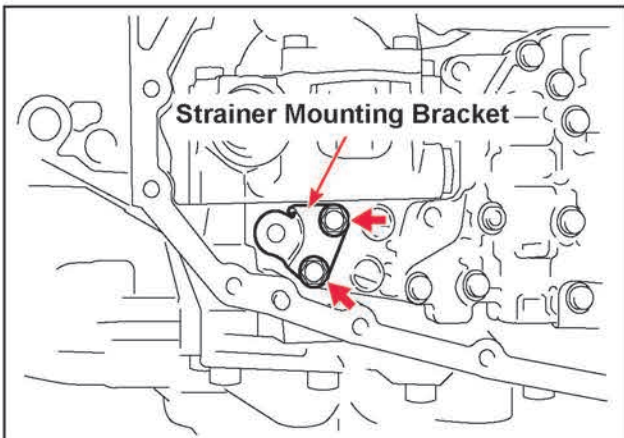

137. Install the oil strainer mounting bracket onto the valve body with its mounting bolts.

Tighten the two bolts to 7.9Nm (70 in-lbs.).

2	Long Bolts	25 mm (.984 in.)
---	------------	------------------

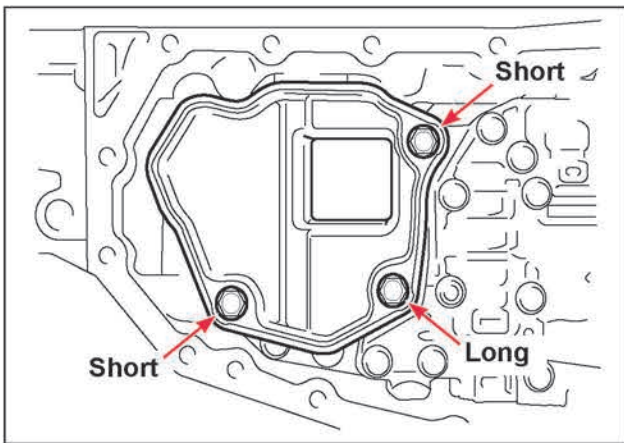

138. Verify the new o-ring is attached on the new oil strainer (2824A007). Coat the new o-ring with petroleum jelly, then install the new oil strainer onto the valve body.

Install the one **LONG** and two **SHORT** oil strainer mounting bolts into the locations indicated. Tighten oil strainer mounting bolts to 7.9Nm (70 in-lbs.).

1	Long Bolt	44 mm (1.73 in.)
2	Short Bolts	12 mm (.470 in.)

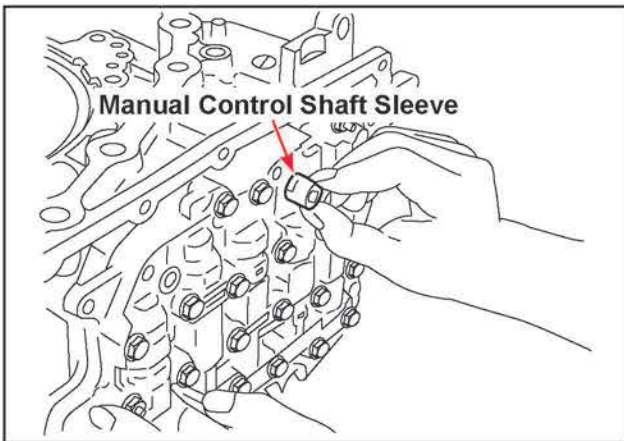

139. Verify the manual control shaft sleeve is flush with the valve body surface.

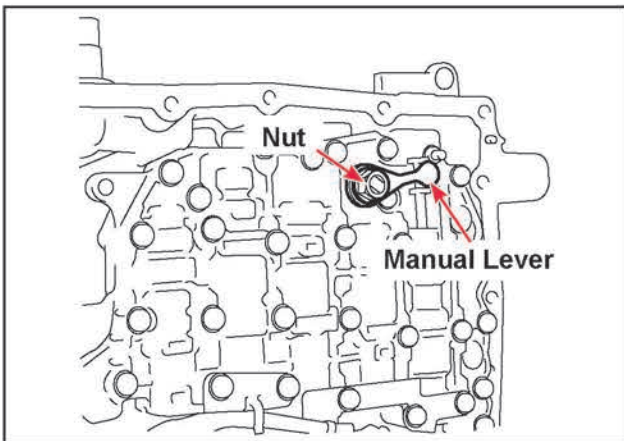

140. Install the manual control valve lever onto the manual control shaft, while at the same time, position the manual control valve to ensure the lever engages the cutout on the manual control valve.

Install the lock washer and nut.

Tighten the nut to 21Nm (16 ft-lbs.).

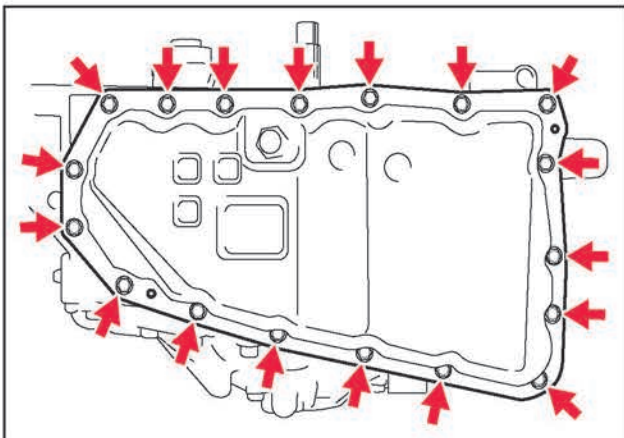

141. Install the new pan gasket (2705A015) and oil pan onto the two dowel pins on the transaxle case. Install the eighteen pan bolts and tighten to 7.9Nm (70 in-lbs.).

18	Short Bolts	15 mm (.590 in.)
----	-------------	------------------

Install a new drain plug gasket (2705A013).

Install the drain plug into the pan.

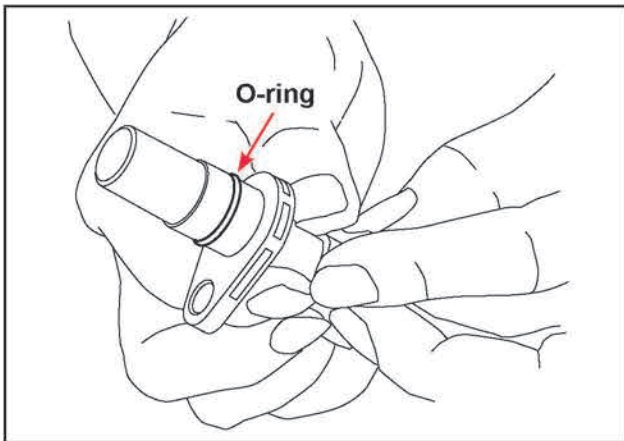

142. Install a new o-ring (8652A017) into the groove on the secondary pulley speed sensor. Coat the o-ring with petroleum jelly.

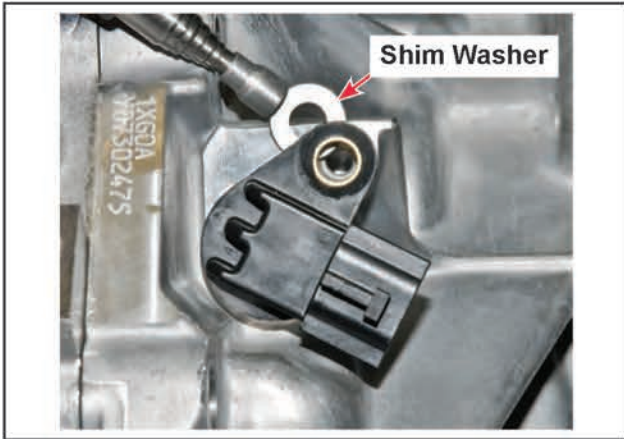

143. Using a stick magnet, hold the shim into position under the secondary pulley speed sensor mounting tab while installing the speed sensor into the transaxle case.

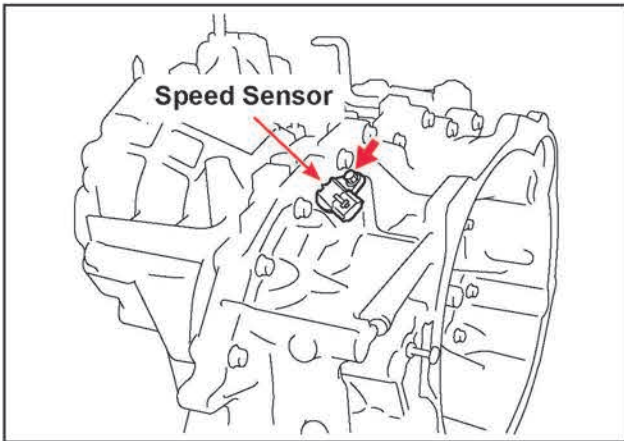

144. Install the secondary pulley speed sensor mounting bolt.

Tighten the bolt to 5.8Nm (52 in-lbs.).

1	Short Bolt	17 mm (.669 in.)
---	------------	------------------

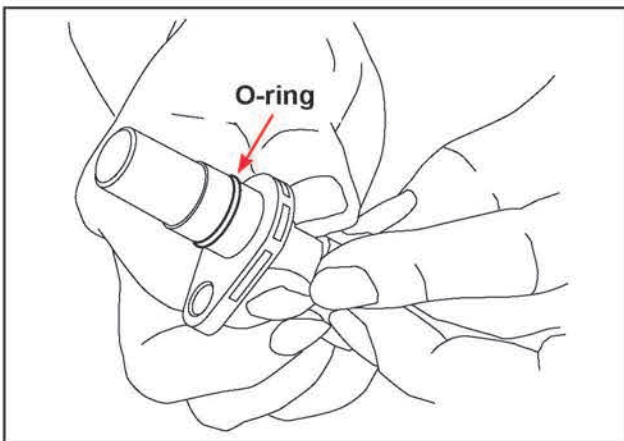

145. Install a new o-ring (8652A017) into the groove on the primary pulley speed sensor. Coat the o-ring with petroleum jelly.

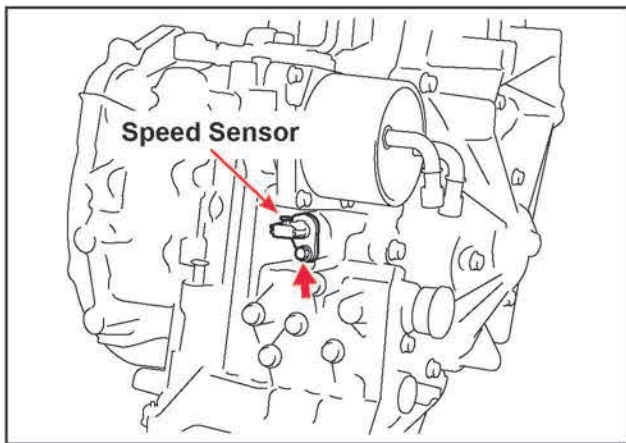

146. Install the primary pulley speed sensor.

Tighten the bolt to 5.8Nm (52 in-lbs.).

1	Short Bolt	17 mm (.669 in.)
---	------------	------------------

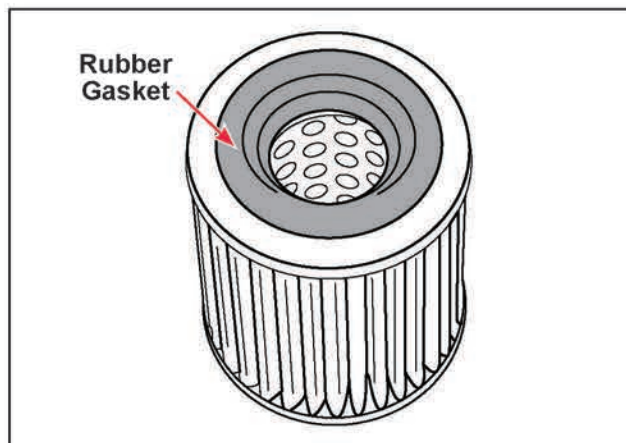

147. Verify the rubber gasket is installed on the new ATF warmer / cooler filter (2824A006). Apply a coating of petroleum jelly to the seal.

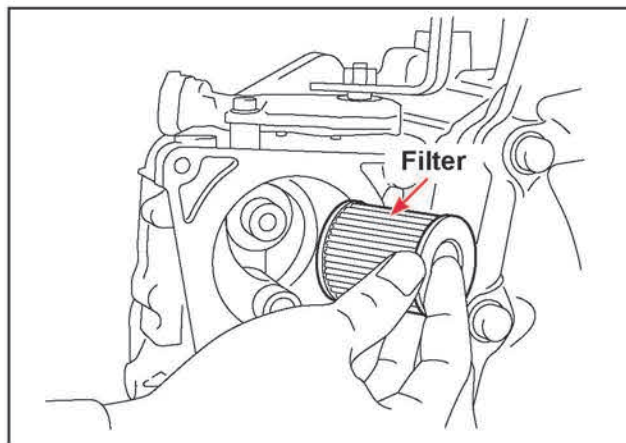

148. Install the new ATF warmer / cooler filter into the opening in the transaxle case as shown.

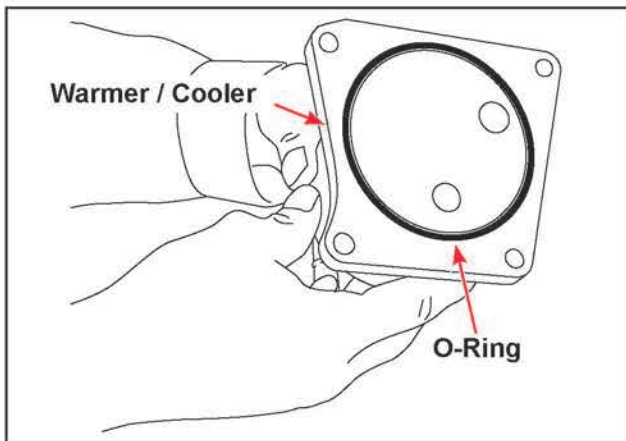

149. Install a new rubber o-ring (2920A096) in the groove on the new ATF warmer / cooler. Coat the o-ring with petroleum jelly.

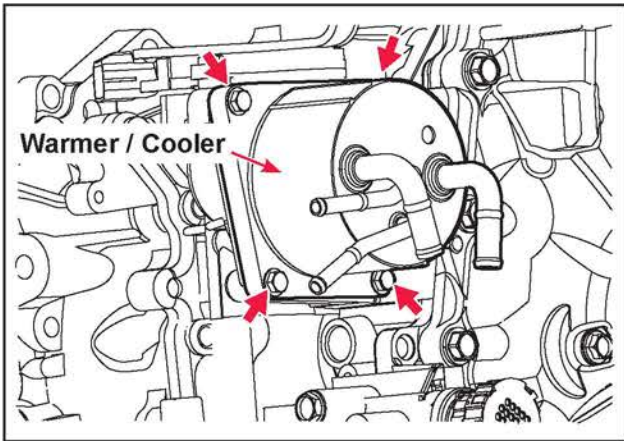

150. Install the ATF warmer / cooler onto the case with the four mounting bolts.

Tighten the bolts to 4.1 Nm (37 in-lbs.).

4	Long Bolts	24 mm (.944 in.)
---	------------	------------------

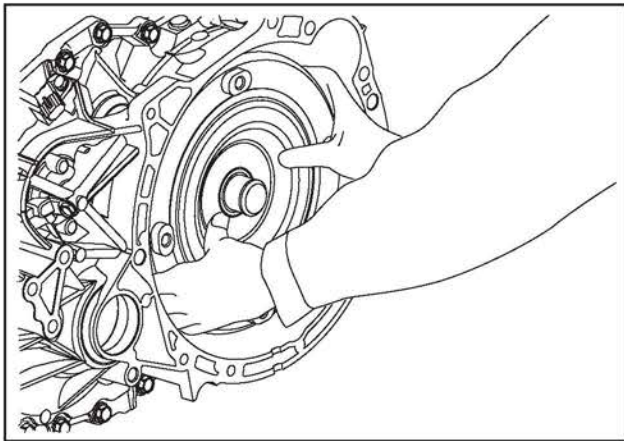

151. Apply a coating of petroleum jelly to the input shaft o-ring then install the torque converter into the transaxle case. While lightly pushing inward rotate the converter back and forth until it is fully seated.

TRANSAXLE FLUSHING

152. Once the CVT has been reinstalled in the vehicle, follow these steps to flush any remaining debris from transaxle. Do not use an automatic transmission flushing machine.

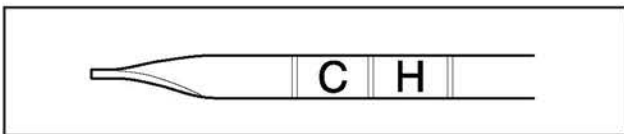

- With the engine running, add sufficient DIA-QUEEN CVTF-J4 transmission fluid to raise the level above the COLD range on the dipstick.
- Drive the vehicle until the fluid temperature has reached at least 158°F. (Monitor Data List Item #5.)
- Drain the fluid from the transaxle
- Refill the transaxle with CVTF-J4 fluid
- Drive the vehicle for 5 minutes.
- Drain the fluid from the transaxle
- One last time, refill the transaxle with CVTF-J4 fluid

WARRANTY INFORMATION

This bulletin is supplied as technical information only and is not an authorization to repair. If an affected vehicle is reported with the described condition, diagnose the condition, repair as described in this bulletin and submit a normal warranty claim using the following information.

CVT Primary and Secondary Pulley Shaft Bearing Replacement

Nature Code: 80G *Cause Code:* 340

Labor Operation No.: 233010 9F *Time Allowance:* Follow L.O.T.S times
for labor operation no.

Warranty Coverage: Powertrain Coverage – Refer to the Superscreen for individual vehicle warranty coverage terms.

Special Warranty Information: Normal warranty procedures apply.