



SHIFT_

PATROL CAB CHASSIS

Specifications

	DX Leaf 3.0 litre intercooled turbo-diesel	ST Coil 3.0 litre intercooled turbo-diesel
Engine		
3.0 litre common rail intercooled turbo-diesel DOHC	●	●
Displacement (cc)	2953	2953
Bore x stroke (mm)	96 x 102	96 x 102
Max. power (kW@rpm) ECE	118@3400	118@3400
Max. torque (Nm@rpm)	380@2000 - 2400	380@2000 - 2400

Transmission		
5-speed manual	●	●
Ratio 1st manual	4.556	4.556
Ratio 2nd manual	2.625	2.625
Ratio 3rd manual	1.591	1.591
Ratio 4th manual	1.000	1.000
Ratio 5th manual	0.836	0.836
Ratio Reverse manual	4.245	4.245
Final drive manual	4.111	4.111
Transfer ratio - low	1:1	1:1
Transfer ratio - high	2:02	2:02

Dimensions		
Overall length (without tray) (mm)	5115	4940
Overall width (without tray) (mm)	1840/1940 [^]	1940
Overall height (without tray) (mm)	1895/1875 [^]	1875
Wheelbase (mm)	2970	2970
Minimum turning circle kerb to kerb (m)	12.5	12.5
Overhang - front	930	930
Overhang - rear	1205	1030
Gross Vehicle Mass (GVM [^]) (kg)	3400	3150
Tare mass (without tray) kg [^] including options	2117/2135 [^]	2014
Carrying capacity (kg)	1283/1265 [^]	1136
Ground clearance unladen (mm)	235	235
Angle of approach	36	35
Angle of departure	30	30

Rated Towing Capacity[^]		
Trailer with brakes (kg)	3200	3200
Trailer without brakes (kg)	750	750
Towball download (kg)	See table	See table

Fuel		
Fuel type - diesel	●	●
Fuel tank capacity (litres)	95	95
Sub fuel tank capacity (litres)	80	80
Fuel economy l/100km (manual) (combined ADR 81/02 ⁹⁹)	11.4	11.4

Mechanical		
Front brakes - ventilated discs	●	●
Rear brakes - ventilated discs	●	●
Limited Slip Differential (LSD)	●	●
Rear drum brakes	●	●
Load sensing brake valve	●	●
Manual free wheeling hubs	●	●
Manual idle control	●	●
Power steering	●	●

	DX Leaf 3.0 litre intercooled turbo-diesel	ST Coil 3.0 litre intercooled turbo-diesel
Front - 3 link coil suspension	●	●
Front stabiliser	●	●
Rear - 5 link coil springs		●
Rear stabiliser		●
Rear - progressive rate leaf springs	●	
Semi floating rear axle		●
Full floating rear axle	●	

Wheels/Tyres		
16x8JJ steel wheels with 265/75R16 tyres	Opt	●
5.5Fx16 steel wheels with 7.50R16 LT tyres	●	
Full size steel spare wheel	●	●

Interior		
Seating capacity	2	2
Front bucket seats	●	●
Seat trim	Moquette	Moquette
Power windows	●	●
Central locking	●	●
4 spoke steering wheel	●	●
Tilt adjustable steering	●	●
6 CD in-dash auto-changer with AM/FM radio		●
Single CD player with AM/FM radio	●	
Bluetooth [®] handsfree phone system	●	●
Auxiliary MP3 player input jack	●	●
iPod ^d connectivity via USB connection	●	●
Speakers	2	2
12v power socket	●	●
Large door pockets	●	●
Door armrests	●	●
Centre console with lid	●	●
Air-conditioning	●	●
Antenna	●	●
Cupholders	●	●
Roof console with sunglasses holder		●
Map lights		●
Sunvisor	●	●
Front assist grip(s)	●	●
Floor trim	Vinyl	Carpet
Courtesy lights	●	●

Instrumentation		
Odometer, tachometer and trip meter	●	●
Oil pressure and charge warning light	●	●
Brake warning light	●	●
Low fuel warning light		●
Door ajar warning light		●
Seatbelt warning lamp	●	●
Glow indicator	●	●
Sediment filter warning light	●	●
4WD indicator light	●	●
Fuel/water temperature gauges	●	●
Sub fuel tank gauge	●	●
Digital clock	●	●



SHIFT_

PATROL CAB CHASSIS

Specifications

	DX Leaf 3.0 litre intercooled turbo-diesel	ST Coil 3.0 litre intercooled turbo-diesel
Safety		
Driver and front passenger front-impact SRS airbags	•	•
Collapsible steering column	•	•
Door side intrusion bars	•	•
3 point front Emergency Locking Retractor (ELR) seatbelts	•	•
Laminated windscreen	•	•
Hazard warning lights	•	•
Day/night rear view mirror	•	•
Exterior		
Over fender flares	Opt	•
Side steps		•
Lockable fuel filler caps	•	•
Front mudflaps	•	•
Front & rear towing hooks	•	•
Door mirrors	•	•
Colours		
Polar White (QM1)	•	•
Platinum (KY0)*	•	•
Desert Gold (EY0)*	•	•
Black Obsidian (KH3)	•	•
Warranty		
3 year/100,000kms	•	•
3 year 24-Hour Roadside Assistance Program	•	•
Genuine Nissan Extended Warranty	Opt	Opt

Opt
 Optional
 Not available
 Standard

LEAF SPRING TOWBALL DOWNLOAD:

Towball Download must not exceed 250kg at GVM.** To increase the towball download above 250kg, the vehicle mass needs to be decreased as per the following table.

Towball download	Vehicle Mass
250kg	GVM** (All Variants)
300kg	Reduce loaded vehicle mass below GVM** by 85kg
320kg	Reduce loaded vehicle mass below GVM** by 120kg

COIL SPRING TOWBALL DOWNLOAD:

Towball Download must not exceed 100kg at GVM.** To increase the towball download above 100kg, the vehicle mass needs to be decreased as per the following table.

Towball download	Vehicle Mass
100kg	GVM** (All Variants)
150kg	Reduce loaded vehicle mass below GVM** by 115kg
200kg	Reduce loaded vehicle mass below GVM** by 200kg
250kg	Reduce loaded vehicle mass below GVM** by 290kg
300kg	Reduce loaded vehicle mass below GVM** by 365kg
320kg	Reduce loaded vehicle mass below GVM** by 400kg

* Indicates a metallic colour which is available at extra cost

** GVM = Gross Vehicle Mass. GVM includes the driver, passengers, full fuel tank and luggage.

* Tare mass = unladen mass of vehicle with 10 litres of fuel, excludes tray.

* Figures have been calculated in accordance with ADR81/02. Actual fuel consumption will vary depending on driving conditions, driver behavior, the condition of your vehicle and the accessories fitted.

^ With optional wheels and tyres.

† Towing capacity is subject to towbar/towball capacity. The capacity may be reduced if a non Nissan Genuine towbar is fitted.

‡ iPod is a registered trade mark of Apple Inc.

Dimensions

See specification pages for dimensions of all models.

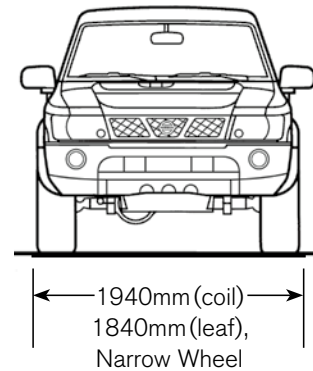
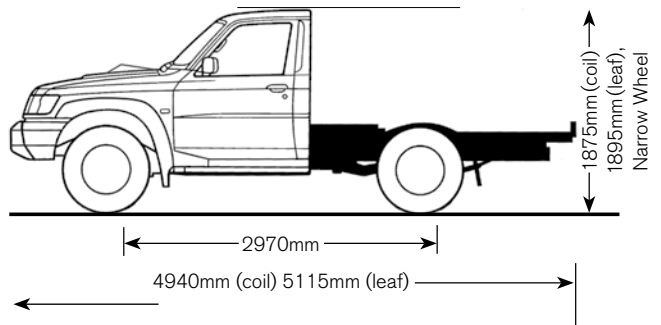

Moquette seat trim – ST Coil and DX Leaf.

my nissan
our comprehensive ownership experience



FINANCIAL SERVICES

For more information please visit nissan.com.au/owners, ask your Nissan Dealer or phone 1800 035 035 during normal business hours.

Follow us: @Nissan_Aus

Like us: Nissan Australia

Check out: NissanAustralia Channel



All illustrations, information and specifications presented and referred to in this brochure were correct at the time this brochure was approved for printing. The colours in the photographs may vary from actual colours. However, Nissan Motor Co (Australia) Pty. Ltd. reserves the right, subject to the laws of Australia and/or the regulations of any competent authority which may apply from time to time, at its discretion at anytime and without prior notice to discontinue or change the models, features, specifications, designs and prices of the products referred to in this brochure and any optional equipment therefore without incurring any liability whatsoever to any purchaser or prospective purchaser of any such products. Some of the items referred to herein are optional at extra cost. Some options may be required in combination with other options. Always consult your Nissan Dealer for the latest information on models, specifications, features, prices, options and availability. Nissan Motor Co (Australia) Pty. Ltd. ACN 004 663 156. Updated July 2012. PCC0126.