

nissan.com.au



Polar White (QM1)[†]



Platinum (KY0)^{**}



Desert Gold (EY0)^{**}



Black Obsidian (KH3)[†]



Printed colours may vary from the actual paint colours.
[†]Indicates a metallic paint, which is available at extra cost. ^{**}Towbar and tray optional extras.

PATROL CAB CHASSIS

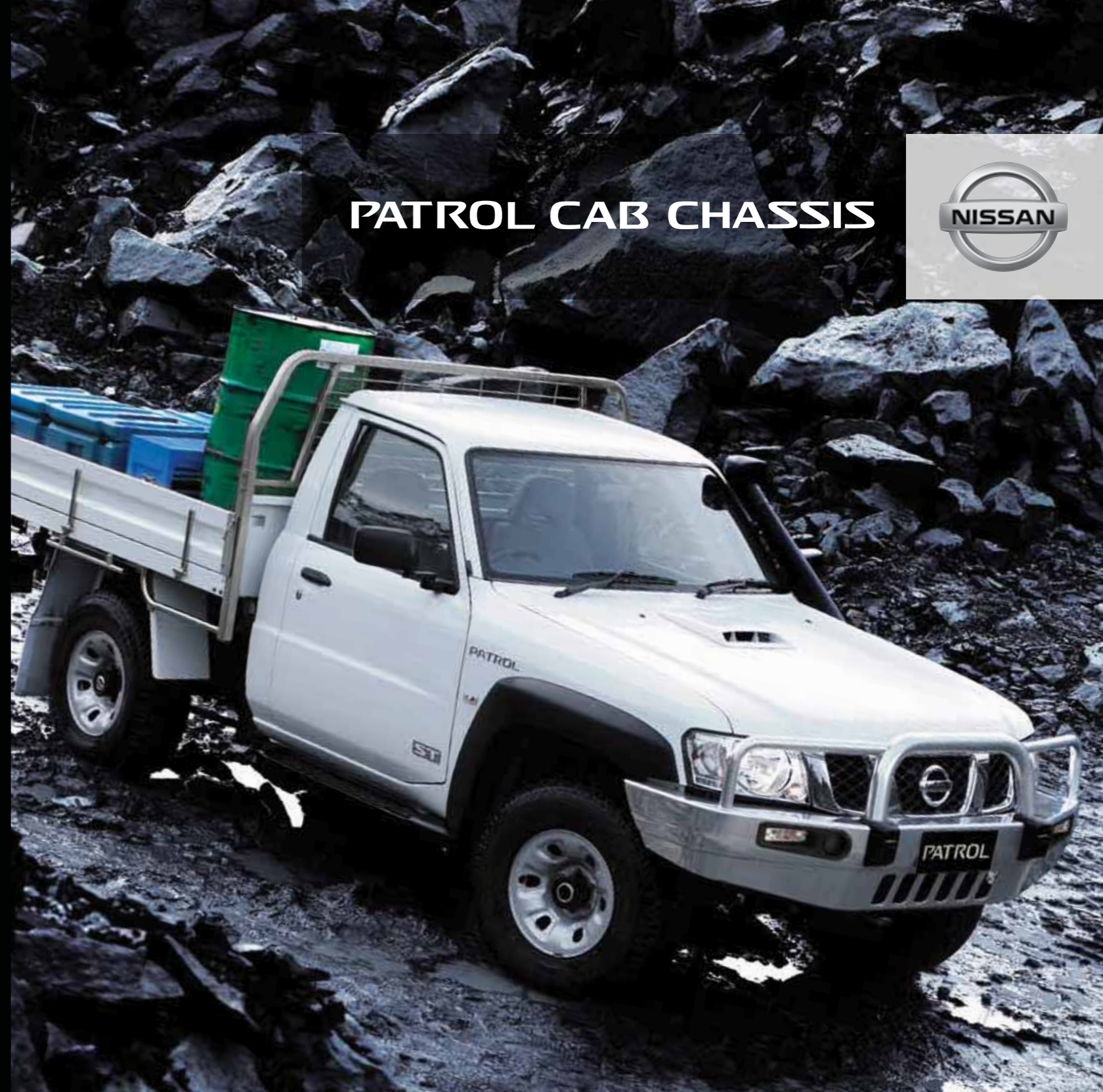



The Nissan Patrol Cab Chassis is a tough, powerful workhorse that'll help you get the job done. It also works just as hard at making your life easier by including plenty of useful features and comforts. The Patrol Cab Chassis. It will shift what needs shifting; it will shift the way you work; it will **shift the way you move.**

Polar White ST Coil with optional bullbar, snorkel and steel tray.

So, what's under the hood?

The Nissan Patrol Cab Chassis is powered by a 3.0 litre common-rail turbo diesel engine with intercooler. The engine is highly responsive across the entire rev range, which makes it great for everything from towing to overtaking on the open road. Power is an impressive 118kW at 3,400rpm with plenty of low down grunt as well – 380Nm at a range of 2,000 to 2,400rpm. On top of that, the Patrol Cab Chassis has a 5-speed manual transmission with double cone synchromesh on the 1st, 2nd and 3rd gears and a chain driven transfer case. This truck's ready for work.



Desert Gold DX Leaf with optional snorkel, bullbar, winch and aluminium tray.



King of the load.

The Patrol Cab Chassis offers you a massive 3,200kg braked towing capacity. That should take care of pretty much anything you need to shift. You will also find that the Limited Slip Differential (LSD) maintains traction on even the slipperiest of surfaces. In addition, the Patrol Cab Chassis comes in a choice of leaf or coil suspension. The all terrain suspension on the coil model incorporates an advanced heavy duty coil spring suspension, with three links in the front and five links in the rear, as well as telescopic shock absorbers for a smoother ride. While the leaf spring model offers the ride comfort of coil springs at the front with the load carrying capacity of leaf springs at the rear.

A powerful appearance.

The Nissan Patrol Cab Chassis proves you can be rugged without looking it. Solidly handsome, it includes stylish features such as a chrome grille surround and on the ST coil model, fender flares and side steps. The immensely strong steel body of the Patrol Cab Chassis has been built on a separate ladder chassis, designed with rungs for added rigidity and strength. And it can keep moving no matter what the terrain with excellent ground clearance and a 700mm wading depth. All Patrol Cab Chassis models come with a 95 litre main tank and an 80 litre sub tank as standard equipment. That means fewer trips to fill up and more time to get the job done.

Black Obsidian DX Leaf with optional bullbar, winch, snorkel and aluminium tray.

Loads of storage.

The Nissan Patrol Cab Chassis includes a number of practical and versatile storage compartments. Large pockets in the doors can carry plenty, and the ST model has an overhead holder for sunglasses.



Loads of comfort.

Even before you get in, the Patrol Cab Chassis is making your job easier – wide doors make entry and exit a cinch. Once inside, the spacious interior gives you exceptional head, shoulder and leg room. All models feature bucket seats with durable cloth and head restraints that have been specifically designed to reduce fatigue and provide comfort and support. There's also power steering, an adjustable steering column and a driver's footrest. A single in-dash CD player with AM/FM radio plus an auxiliary MP3 player input jack lets you listen to your favorite songs, or step up to a 6 CD changer if you choose the ST model. All models also come standard with Bluetooth® handsfree phone system for easy communication on the road and iPod* connectivity via USB connection.

*iPod is a registered trade mark of Apple Inc.

Strong on safety.

The Patrol Cab Chassis comes equipped with plenty of safety features including dual front airbags as standard, extended and reinforced crumple zones, a collapsible steering column and steel anti-intrusion bars.



Patrol DX Leaf.



Black Obsidian DX Leaf with optional bullbar, winch, snorkel and aluminium tray.

- 3.0 litre common rail turbo-diesel engine with intercooler
- 5-speed manual transmission
- Limited Slip Differential (LSD)
- 95 litre main fuel tank
- 80 litre sub fuel tank
- Front disc brakes
- Coil spring front suspension
- Leaf spring rear suspension
- Centre console
- Bucket seats
- Moquette trim
- Central locking
- Power windows
- Air-conditioning
- Single in-dash CD player with AM/FM radio
- Manual antenna
- iPod* connectivity via USB connection
- Bluetooth® handsfree phone system
- Auxiliary MP3 player input jack
- Vinyl floor covering
- Dual SRS airbags

Patrol ST Coil.



Polar White ST Coil with optional bullbar, snorkel and steel tray.

- All features of the Patrol Cab Chassis DX Leaf plus/or:
- Carpet floor covering
 - Roof console with map lights
 - 6 CD in-dash auto changer with AM/FM radio
 - Side steps
 - Four wheel disc brakes
 - Four wheel coil spring suspension



*iPod is a registered trade mark of Apple Inc.

Polar White ST Coil with optional bullbar, snorkel and steel tray.

myNissan is a **complete ownership experience**, which helps you get the most out of your Nissan. As part of myNissan, you will receive a 3 year/100,000kms warranty and have access to 24-Hour Roadside Assistance for 3 years. Just call us if you lock your keys in the car, have a flat tyre or battery, or have run out of fuel, and we'll help get you back on the road at no charge. You can also take the option to extend your warranty for up to 6 years.

We recognise that buying a car is a significant investment and the extensive network of Nissan Dealers will help you maintain and protect it. That's why, as part of myNissan, you're entitled to 6 years or 120,000kms* of **Capped Price Service**. This means you'll always know the maximum price you'll pay when you come in for your next Scheduled Service at any Nissan Dealer, Australia wide. What's more, Nissan technicians are factory-trained experts that utilise dedicated diagnostic equipment and genuine parts to keep your vehicle in top condition. Thereby giving you the peace of mind that your Nissan is in the safest of hands.

The myNissan **iPhone app** lets you request roadside assistance and advise of your location using your phone's GPS, plan trips, search for locations, plus set registration, service and parking expiry reminders. Nissan also offers a variety of **Nissan Genuine Accessories** to protect, enhance and personalise your Patrol Cab Chassis. A towbar will increase your load carrying options, while a snorkel, weathershields and headlamp protectors will help take it just about anywhere. Ask your Nissan Dealer about the entire list of Patrol Cab Chassis accessories.

Nissan Financial Services has a range of finance options at very competitive rates and terms as well as various insurance solutions to protect you and your vehicle.

Nissan has introduced **Blue Citizenship**, a new way for us to look at our business, which reflects our desire to be a model corporate citizen and play a role in aiding the sustainability of our earth and its resources. Blue Citizenship involves contributing to communities, promoting diversity, delivering mobility to more people all over the world and helping to protect the environment.

my nissan
comprehensive owner support



*Ask your Nissan Dealer to explain exactly what items are covered in each Scheduled Service. Applies to the first 12 X 10,000kms scheduled service intervals for up to 6 years/120,000kms (whichever occurs first). Some exclusions apply. Ask your Nissan Dealer or visit nissan.com.au/cpstcs for full terms and conditions.

Polar White ST Coil with optional bullbar, snorkel and steel tray.



Specifications

	DX Leaf 3.0 litre intercooled turbo-diesel	ST Coil 3.0 litre intercooled turbo-diesel
Engine		
3.0 litre common rail intercooled turbo-diesel DOHC	●	●
Displacement (cc)	2953	2953
Bore x stroke (mm)	96 x 102	96 x 102
Max. power (kW@rpm) ECE	118@3400	118@3400
Max. torque (Nm@rpm)	380@2000 - 2400	380@2000 - 2400

Transmission		
5-speed manual	●	●
Ratio 1st manual	4.556	4.556
Ratio 2nd manual	2.625	2.625
Ratio 3rd manual	1.591	1.591
Ratio 4th manual	1.000	1.000
Ratio 5th manual	0.836	0.836
Ratio Reverse manual	4.245	4.245
Final drive manual	4.111	4.111
Transfer ratio - low	1:1	1:1
Transfer ratio - high	2:02	2:02

Dimensions		
Overall length (without tray) (mm)	5115	4940
Overall width (without tray) (mm)	1840/1940*	1940
Overall height (without tray) (mm)	1895/1875*	1875
Wheelbase (mm)	2970	2970
Minimum turning circle kerb to kerb (m)	12.5	12.5
Overhang - front	930	930
Overhang - rear	1205	1030
Gross Vehicle Mass (GVM**)(kg)	3400	3150
Tare mass (without tray) kg* including options	2117/2135*	2014
Carrying capacity (kg)	1283/1265*	1136
Ground clearance unladen (mm)	235	235
Angle of approach	36	35
Angle of departure	30	30

Rated Towing Capacity*		
Trailer with brakes (kg)	3200	3200
Trailer without brakes (kg)	750	750
Towball download (kg)	See table	See table

Fuel		
Fuel type - diesel	●	●
Fuel tank capacity (litres)	95	95
Sub fuel tank capacity (litres)	80	80
Fuel economy l/100km (manual) (combined ADR 81/02**)	11.4	11.4

	DX Leaf 3.0 litre intercooled turbo-diesel	ST Coil 3.0 litre intercooled turbo-diesel
Mechanical		
Front brakes - ventilated discs	●	●
Rear brakes - ventilated discs		●
Limited Slip Differential (LSD)	●	●
Rear drum brakes	●	
Load sensing brake valve	●	●
Manual free wheeling hubs	●	●
Manual idle control	●	●
Power steering	●	●
Front - 3 link coil suspension	●	●
Front stabiliser	●	●
Rear - 5 link coil springs		●
Rear stabiliser		●
Rear - progressive rate leaf springs	●	
Semi floating rear axle		●
Full floating rear axle	●	

Wheels/Tyres		
16x8JJ steel wheels with 265/75R16 tyres	Opt	●
5.5fx16 steel wheels with 7.50R16 LT tyres	●	
Full size steel spare wheel	●	●

Interior		
Seating capacity	2	2
Front bucket seats	●	●
Seat trim	Moquette	Moquette
Power windows	●	●
Central locking	●	●
4 spoke steering wheel	●	●
Tilt adjustable steering	●	●
6 CD in-dash auto-changer with AM/FM radio		●
Single CD player with AM/FM radio	●	
Bluetooth® handsfree phone system	●	●
Auxiliary MP3 player input jack	●	●
iPod® connectivity via USB connection	●	●
Speakers	2	2
12v power socket	●	●
Large door pockets	●	●
Door armrests	●	●
Centre console with lid	●	●
Air-conditioning	●	●
Antenna	●	●
Cupholders	●	●
Roof console with sunglasses holder	●	●
Map lights	●	●
Sunvisor	●	●
Front assist grip(s)	●	●

	DX Leaf 3.0 litre intercooled turbo-diesel	ST Coil 3.0 litre intercooled turbo-diesel
Floor trim	Vinyl	Carpet
Courtesy lights	●	●

Instrumentation		
Odometer, tachometer and trip meter	●	●
Oil pressure and charge warning light	●	●
Brake warning light	●	●
Low fuel warning light	●	●
Door ajar warning light		●
Seatbelt warning lamp	●	●
Glow indicator	●	●
Sediment filter warning light	●	●
4WD indicator light	●	●
Fuel/water temperature gauges	●	●
Sub fuel tank gauge	●	●
Digital clock	●	●

Safety		
Driver and front passenger front-impact SRS airbags	●	●
Collapsible steering column	●	●
Door side intrusion bars	●	●
3 point front Emergency Locking Retractor (ELR) seatbelts	●	●
Laminated windscreen	●	●
Hazard warning lights	●	●
Day/night rear view mirror	●	●

Exterior		
Over fender flares	Opt	●
Side steps		●
Lockable fuel filler caps	●	●
Front mudflaps	●	●
Front & rear towing hooks	●	●
Door mirrors	●	●

Colours		
Polar White (QM1)	●	●
Platinum (KYD)*	●	●
Desert Gold (EYD)*	●	●
Black Obsidian (KH3)	●	●

Warranty		
3 year/100,000kms	●	●
3 year 24-Hour Roadside Assistance Program	●	●
Genuine Nissan Extended Warranty	Opt	Opt

Opt Optional Not available Standard

LEAF SPRING TOWBALL DOWNLOAD:

Towball Download must not exceed 250kg at GVM.** To increase the towball download above 250kg, the vehicle mass needs to be decreased as per the following table.

Towball download	Vehicle Mass
250kg	GVM** (All Variants)
300kg	Reduce loaded vehicle mass below GVM** by 85kg
320kg	Reduce loaded vehicle mass below GVM** by 120kg

COIL SPRING TOWBALL DOWNLOAD:

Towball Download must not exceed 100kg at GVM.** To increase the towball download above 100kg, the vehicle mass needs to be decreased as per the following table.

Towball download	Vehicle Mass
100kg	GVM** (All Variants)
150kg	Reduce loaded vehicle mass below GVM** by 115kg
200kg	Reduce loaded vehicle mass below GVM** by 200kg
250kg	Reduce loaded vehicle mass below GVM** by 290kg
300kg	Reduce loaded vehicle mass below GVM** by 365kg
320kg	Reduce loaded vehicle mass below GVM** by 400kg

* Indicates a metallic colour which is available at extra cost

** GVM = Gross Vehicle Mass. GVM includes the driver, passengers, full fuel tank and luggage.

* Tare mass = unladen mass of vehicle with 10 litres of fuel, excludes tray.

** Figures have been calculated in accordance with ADR81/02. Actual fuel consumption will vary depending on driving conditions, driver behavior, the condition of your vehicle and the accessories fitted.

^ With optional wheels and tyres.

† Towing capacity is subject to towbar/towball capacity. The capacity may be reduced if a non Nissan Genuine towbar is fitted.

‡ iPod is a registered trade mark of Apple Inc.

my nissan
comprehensive owner support



FINANCIAL SERVICES



For more information please visit nissan.com.au, ask your Nissan Dealer or phone 1800 035 035 during normal business hours.

Follow us: Nissan_Aus



Like us: Nissan Australia



Check out: NissanAustralia Channel



Dimensions

See specification pages for dimensions of all models.

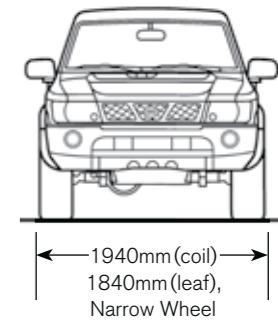
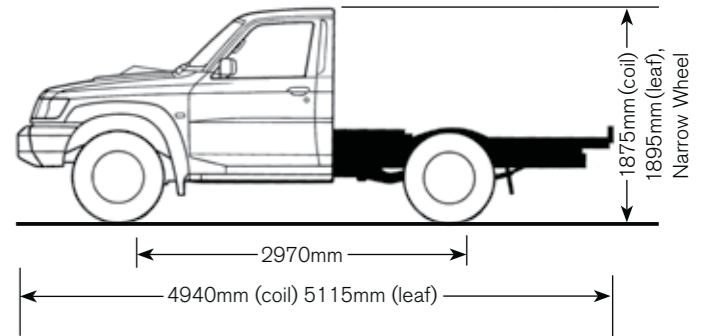

Moquette seat trim - ST Coil and DX Leaf.

All illustrations, information and specifications presented and referred to in this brochure were correct at the time this brochure was approved for printing. The colours in the photographs may vary from actual colours. However, Nissan Motor Co (Australia) Pty. Ltd. reserves the right, subject to the laws of Australia and/or the regulations of any competent authority which may apply from time to time, at its discretion at anytime and without prior notice to discontinue or change the models, features, specifications, designs and prices of the products referred to in this brochure and any optional equipment therefore without incurring any liability whatsoever to any purchaser or prospective purchaser of any such products. Some of the items referred to herein are optional at extra cost. Some options may be required in combination with other options. Always consult your Nissan Dealer for the latest information on models, specifications, features, prices, options and availability. Nissan Motor Co (Australia) Pty. Ltd. ACN 004 663 156. Updated Sept 2011. PCC0124.