



Innovation
that excites

NISSAN PATROL CAB CHASSIS



Polar White ST Coil with optional bull bar, snorkel and aluminium tray.



WORKS 365 DAYS A YEAR. THE NISSAN PATROL CAB CHASSIS

Life on the land is relentless and unforgiving. You need a workhorse that's just as tough. One that can handle a little punishment.

The Nissan Patrol Cab Chassis is the one. As resilient as they come, from its sturdy frame to its big, powerful heart, you can push it day in, day out, 365 days a year with a work ethic second to none. And despite its tough exterior, there's a little softness on the inside with the added extras you need to help you keep on keeping on through all of life's little challenges.



AN ENGINE THAT'S READY FOR ANYTHING

The Nissan Patrol Cab Chassis range gives you all the grunt you need. All models are powered by a 3.0 litre turbo-diesel engine with intercooler and an impressive 118kW at 3,400rpm; giving you raw power on hand whenever you need and plenty of low down torque with 380Nm at a range of 2,000 to 2,400rpm. And although it's packed with grunt, there's no grind when it comes to the 5-speed manual transmission. Double cone synchromesh on the 1st, 2nd and 3rd gears, complete with a chain driven transfer case, delivers smooth, responsive transmission whether you're heading up hill or down the back paddock.

Desert Gold DX Leaf with optional snorkel, bull bar, winch and aluminium tray.

Polar White DX Leaf with optional tow bar and aluminium tray.



32 SHEEP

1,600 CHICKENS

8,311 CANS OF BAKED BEANS

53,333 EGGS

351 TYRES

24,615 POTATOES

78 ROLLS OF BARBED WIRE

6 HORSES

23 FULL GROWN PIGS

22 FULL OIL DRUMS

21,333 TOMATOES

8 LARGE HAY BALES

4 VERY LARGE COWS

40,000 CARROTS

**WHAT DOES
3,200KG
LOOK LIKE?**

The Nissan Patrol Cab Chassis offers a massive 3,200kg braked towing capacity* making sure you'll always be able to shift any load whether it's for work during the week or towing on the weekends.

An inside cabin switch allows you to easily engage the rear differential lock when facing different wheel traction in 4WD situations. By locking the rear differential it forces both wheels to turn in unison, providing a significant traction advantage to keep you moving.

In suspension you have the choice of the DX model with leaf spring rear suspension (coil up the front), or the ST model with all round coil spring suspension. The all terrain suspension on the ST Coil gives you advanced heavy-duty coil spring suspension, with three links in the front and five links in the rear, as well as telescopic shock absorbers for a smoother ride. The DX Leaf spring gives you the ride comfort of coil springs at the front, with the load carrying capacity of leaf springs at the rear. Both variants have a three link solid beam axel front suspension with stabiliser bar.

The strength of the Nissan Patrol Cab Chassis is second to none, with a steel body built on a separate ladder chassis for increased strength. And you can put it through its paces on all terrain with a wading depth of 700mm and excellent ground clearance. The rugged exterior is enhanced with a chrome grille surround, over-fender flares and side steps. Every Nissan Patrol Cab Chassis model comes with a 95 litre main tank and an 80 litre sub tank as standard. All in all, this is one hard to beat mother.

*Towing capacity is subject to towbar/towball capacity and is based on the fitment of a Genuine Nissan towbar. Towing capacity figure described is a maximum figure. Actual towing capacity depends on the laden mass of the vehicle, driving conditions, fitment of any accessories or towing equipment limitations including the maximum towball download.



Black Obsidian DX Leaf with optional snorkel, bull bar, winch and aluminium tray.



IT'S WHAT'S INSIDE THAT COUNTS

When you spend so much time in your vehicle, you want to make sure it's damn comfy inside. All Nissan Patrol Cab Chassis models give you exceptional head, shoulder and legroom, with deep supportive bucket seats in a durable woven cloth, and head restraints designed to reduce fatigue. The adjustable steering column gives you even more room and extra wide doors get you in and out without knocking yourself for six. Plus there's a bunch of smart features to make life easier including; power windows and cruise control, as well as keyless entry system and key leave warning functions. All models feature an AM/FM radio, CD player, an auxiliary MP3 player input jack and a USB Port for iPod* connectivity, as well as a Bluetooth® handsfree phone system to link your compatible mobile phone. There's a heap of versatile storage compartments, including large door pockets, and the ST model comes with an overhead sunglasses holder. And last, but by no means least, the Nissan Patrol Cab Chassis ST model comes with dual front airbags as standard, extended and reinforced crumple zones, Anti-Lock Braking System (ABS), a collapsible steering column and steel anti-intrusion bars, all designed to keep you safe as houses.

ST Coil interior.



Polar White ST Coil with optional bull bar, snorkel and aluminium tray.

Polar White ST Coil with optional bull bar, snorkel and aluminium tray.



my nissan

A complete ownership experience to help you get the most out of your Nissan. It includes the following:

3 YEAR/100,000KM WARRANTY

Receive assurance with a 3 year/100,000kms warranty with the option of extending further for up to 6 years.

24-HOUR ROADSIDE ASSISTANCE FOR 3 YEARS

No matter where you're planning to journey, you'll have the peace of mind of knowing that if you lock your keys in the car, have a flat tyre or battery, or run out of fuel, we'll help get you back on the road at no charge*.

CAPPED PRICE SERVICE

For 6 years or 120,000kms* you'll always know the maximum price you'll pay when you come in for your next Scheduled Service at any Nissan Dealer.

FACTORY-TRAINED TECHNICIANS

Using dedicated diagnostic equipment and genuine parts they'll keep your vehicle in top condition.

MYNISSAN IPHONE APP

Request roadside assistance and advise of your location using your phone's GPS, plan trips, search for locations, plus set registration, service and parking expiry reminders.

NISSAN GENUINE ACCESSORIES

Your Nissan Dealer can show you a variety of accessories to protect, enhance and personalise your Nissan Patrol Cab Chassis.

FINANCIAL SERVICES

Choose from a range of finance options at very competitive rates and terms, as well as various insurance solutions to protect you and your vehicle.

*Terms and conditions apply, please visit nissan.com.au/roadsideassistance. *Ask your Nissan Dealer to explain exactly what items are covered in each Scheduled Service. Applies to the first 12 X 10,000kms scheduled service intervals for up to 6 years/120,000kms (whichever occurs first). Some exclusions apply. Ask your Nissan Dealer or visit nissan.com.au/cpstcs for full terms and conditions.



Polar White (QM1)*



Platinum (KY0)**



Desert Gold (EY0)**



Black Obsidian (KH3)†



Woven seat trim – DX



Moquette seat trim – ST

DX Leaf Features



ST Coil Features



- 3.0 litre common rail turbo-diesel engine with intercooler
- 5 speed manual transmission
- Limited Slip Differential (LSD)
- 95 litre main fuel tank
- 80 litre sub fuel tank
- Front brakes – ventilated discs
- Coil spring front suspension
- Leaf spring rear suspension
- Full size steel spare wheel
- Woven seat trim
- Power windows
- Central locking
- Bluetooth hands-free phone system
- iPod[^] connectivity via USB connection
- Auxiliary MP3 player input jack
- Air-conditioning
- Driver and front passenger front-impact SRS airbags
- Over fender flares
- Vinyl floor trim

All the features of the DX Leaf model plus/or:

- Rear brakes – ventilated discs
- Coil spring rear suspension
- Moquette seat trim
- Roof console with sunglasses holder and map lights
- Side steps
- Carpet floor trim

Optional aluminium tray shown. [^]iPod is registered trademark of Apple Inc.

Dimensions

See specification pages for dimensions of all models.

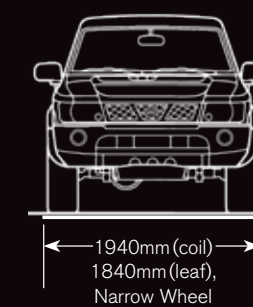
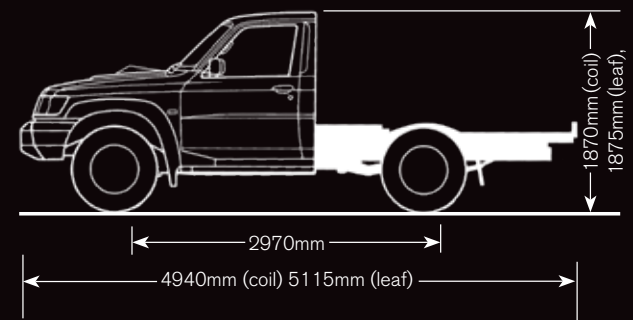

Minor trim variations may occur from time to time.

Nissan Patrol Cab Chassis ST Coil model shown. In some cases the printed colours may vary from the actual paint colours. †Tray is an optional extra. *Indicates a premium paint, which is available at extra cost.

Specifications

	DX Leaf 3.0 litre intercooled turbo-diesel	ST Coil 3.0 litre intercooled turbo-diesel
Engine		
3.0 litre common rail intercooled turbo-diesel DOHC	<div><ul style="list-style-type: none">●</div>	<div><ul style="list-style-type: none">●</div>
Displacement (cc)	2953	2953
Bore x stroke (mm)	96 x 102	96 x 102
Max. power (kW@rpm) ECE	118@3400	118@3400
Max. torque (Nm@rpm)	380@2000 - 2400	380@2000 - 2400

Transmission		
5-speed manual	<div><ul style="list-style-type: none">●</div>	<div><ul style="list-style-type: none">●</div>
Ratio 1st manual	4.556	4.556
Ratio 2nd manual	2.625	2.625
Ratio 3rd manual	1.591	1.591
Ratio 4th manual	1.000	1.000
Ratio 5th manual	0.836	0.836
Ratio Reverse manual	4.245	4.245
Final drive manual	4.111	4.111
Transfer ratio – low	1.1	1.1
Transfer ratio – high	2.02	2.02

Dimensions		
Overall length (without tray) (mm)	5115	4940
Overall width (without tray) (mm)	1840/1940*	1940
Overall height (without tray) (mm)	1875	1870
Wheelbase (mm)	2970	2970
Minimum turning circle kerb to kerb (m)	12.5	12.5
Overhang – front	940	940
Overhang – rear	1205	1030
Gross Vehicle Mass (GVM ^{**}) (kg)	3400	3150
Tare mass (without tray) kg* including options	2155/2162*	2074
Carrying capacity (kg)	1245/1238 [†]	1076
Ground clearance unladen (mm)	220	235
Approach angle (degrees)	35	35
Departure angle (degrees)	31	32

Rated Towing Capacity [†]		
Trailer with brakes (kg)	3200	3200
Trailer without brakes (kg)	750	750
Towball download (kg)	See table	See table

Fuel		
Fuel type – diesel	<div><ul style="list-style-type: none">●</div>	<div><ul style="list-style-type: none">●</div>
Main fuel tank capacity (litres)	95	95
Sub fuel tank capacity (litres)	80	80
Fuel consumption l/100km (manual) (combined ADR 81/02 ^{cc})	11.4	11.4

Mechanical		
Differential lock	<div><ul style="list-style-type: none">●</div>	<div><ul style="list-style-type: none">●</div>
Front ventilated disc brakes	<div><ul style="list-style-type: none">●</div>	<div><ul style="list-style-type: none">●</div>

Rear ventilated disc brakes		<div><ul style="list-style-type: none">●</div>
Limited Slip Differential (LSD)	<div><ul style="list-style-type: none">●</div>	<div><ul style="list-style-type: none">●</div>
Rear drum brakes	<div><ul style="list-style-type: none">●</div>	
Load sensing brake valve	<div><ul style="list-style-type: none">●</div>	<div><ul style="list-style-type: none">●</div>
Manual free wheeling hubs	<div><ul style="list-style-type: none">●</div>	<div><ul style="list-style-type: none">●</div>
Power steering	<div><ul style="list-style-type: none">●</div>	<div><ul style="list-style-type: none">●</div>
Front - 3 link coil suspension	<div><ul style="list-style-type: none">●</div>	<div><ul style="list-style-type: none">●</div>
Front stabiliser	<div><ul style="list-style-type: none">●</div>	<div><ul style="list-style-type: none">●</div>
Rear - 5 link coil springs		<div><ul style="list-style-type: none">●</div>
Rear stabiliser		<div><ul style="list-style-type: none">●</div>
Rear - progressive rate leaf springs	<div><ul style="list-style-type: none">●</div>	
Semi floating rear axle		<div><ul style="list-style-type: none">●</div>
Full floating rear axle	<div><ul style="list-style-type: none">●</div>	

Wheels/Tyres		
16x8JJ steel wheels with 265/75R16 tyres	<div><ul style="list-style-type: none">Opt</div>	<div><ul style="list-style-type: none">●</div>
5.5Fx16 steel wheels with 7.5DR16 LT tyres	<div><ul style="list-style-type: none">●</div>	
Full size steel spare wheel	<div><ul style="list-style-type: none">●</div>	<div><ul style="list-style-type: none">●</div>

Interior		
Cruise control	<div><ul style="list-style-type: none">●</div>	<div><ul style="list-style-type: none">●</div>
Keyless entry system	<div><ul style="list-style-type: none">●</div>	<div><ul style="list-style-type: none">●</div>
Seating capacity	2	2
Front bucket seats	<div><ul style="list-style-type: none">●</div>	<div><ul style="list-style-type: none">●</div>
Seat trim	Woven	Moquette
Driver auto up/down power windows	<div><ul style="list-style-type: none">●</div>	<div><ul style="list-style-type: none">●</div>
4 spoke steering wheel	<div><ul style="list-style-type: none">●</div>	<div><ul style="list-style-type: none">●</div>
Tilt adjustable steering column	<div><ul style="list-style-type: none">●</div>	<div><ul style="list-style-type: none">●</div>
6 CD in-dash auto-changer with AM/FM radio, MP3 and iPod [‡] connectivity via USB connection		<div><ul style="list-style-type: none">●</div>
Single CD player with AM/FM radio, MP3 and iPod [‡] connectivity via USB connection	<div><ul style="list-style-type: none">●</div>	
Bluetooth [®] handsfree phone system	<div><ul style="list-style-type: none">●</div>	<div><ul style="list-style-type: none">●</div>
2 speakers	<div><ul style="list-style-type: none">●</div>	<div><ul style="list-style-type: none">●</div>
12v power socket	<div><ul style="list-style-type: none">●</div>	<div><ul style="list-style-type: none">●</div>
Large door pockets and storage compartments	<div><ul style="list-style-type: none">●</div>	<div><ul style="list-style-type: none">●</div>
Door armrests	<div><ul style="list-style-type: none">●</div>	<div><ul style="list-style-type: none">●</div>
Centre console with lid	<div><ul style="list-style-type: none">●</div>	<div><ul style="list-style-type: none">●</div>
Air-conditioning	<div><ul style="list-style-type: none">●</div>	<div><ul style="list-style-type: none">●</div>
Antenna	<div><ul style="list-style-type: none">●</div>	<div><ul style="list-style-type: none">●</div>
Cupholders	<div><ul style="list-style-type: none">●</div>	<div><ul style="list-style-type: none">●</div>
Sunglasses holder	<div><ul style="list-style-type: none">●</div>	<div><ul style="list-style-type: none">●</div>
Map lights	<div><ul style="list-style-type: none">●</div>	<div><ul style="list-style-type: none">●</div>
Driver and passenger sunvisor	<div><ul style="list-style-type: none">●</div>	<div><ul style="list-style-type: none">●</div>
Front passenger assist grips	<div><ul style="list-style-type: none">●</div>	<div><ul style="list-style-type: none">●</div>
Floor trim	Vinyl	Carpet
Courtesy lights	<div><ul style="list-style-type: none">●</div>	<div><ul style="list-style-type: none">●</div>

Instrumentation		
Leave key warning	<div><ul style="list-style-type: none">●</div>	<div><ul style="list-style-type: none">●</div>
Odometer, tachometer and trip meter	<div><ul style="list-style-type: none">●</div>	<div><ul style="list-style-type: none">●</div>
Oil pressure and charge warning light	<div><ul style="list-style-type: none">●</div>	<div><ul style="list-style-type: none">●</div>
Brake warning light	<div><ul style="list-style-type: none">●</div>	<div><ul style="list-style-type: none">●</div>
Low fuel warning light	<div><ul style="list-style-type: none">●</div>	<div><ul style="list-style-type: none">●</div>
Door ajar warning light	<div><ul style="list-style-type: none">●</div>	<div><ul style="list-style-type: none">●</div>
Seatbelt warning lamp	<div><ul style="list-style-type: none">●</div>	<div><ul style="list-style-type: none">●</div>
Glow indicator	<div><ul style="list-style-type: none">●</div>	<div><ul style="list-style-type: none">●</div>
Sediment filter warning light	<div><ul style="list-style-type: none">●</div>	<div><ul style="list-style-type: none">●</div>
4WD indicator light	<div><ul style="list-style-type: none">●</div>	<div><ul style="list-style-type: none">●</div>
Fuel/water temperature gauges	<div><ul style="list-style-type: none">●</div>	<div><ul style="list-style-type: none">●</div>
Sub fuel tank gauge	<div><ul style="list-style-type: none">●</div>	<div><ul style="list-style-type: none">●</div>
Digital clock	<div><ul style="list-style-type: none">●</div>	<div><ul style="list-style-type: none">●</div>

Safety		
Anti-Lock Braking System (ABS)		<div><ul style="list-style-type: none">●</div>
Driver and front passenger front-impact SRS airbags	<div><ul style="list-style-type: none">●</div>	<div><ul style="list-style-type: none">●</div>
Collapsible steering column	<div><ul style="list-style-type: none">●</div>	<div><ul style="list-style-type: none">●</div>
Door side intrusion bars	<div><ul style="list-style-type: none">●</div>	<div><ul style="list-style-type: none">●</div>
Driver and passenger 3 point ELR seatbelts	<div><ul style="list-style-type: none">●</div>	<div><ul style="list-style-type: none">●</div>
Laminated windscreen	<div><ul style="list-style-type: none">●</div>	<div><ul style="list-style-type: none">●</div>
Hazard warning lights	<div><ul style="list-style-type: none">●</div>	<div><ul style="list-style-type: none">●</div>
Manual anti-dazzle rear view mirror	<div><ul style="list-style-type: none">●</div>	<div><ul style="list-style-type: none">●</div>

Exterior		
Over fender flares	<div><ul style="list-style-type: none">●</div>	<div><ul style="list-style-type: none">●</div>
Side steps	<div><ul style="list-style-type: none">●</div>	<div><ul style="list-style-type: none">●</div>
Lockable fuel filler caps	<div><ul style="list-style-type: none">●</div>	<div><ul style="list-style-type: none">●</div>
Front mudflaps	<div><ul style="list-style-type: none">●</div>	<div><ul style="list-style-type: none">●</div>
Front & rear towing hooks	<div><ul style="list-style-type: none">●</div>	<div><ul style="list-style-type: none">●</div>
Manual folding and operated door mirrors	<div><ul style="list-style-type: none">●</div>	<div><ul style="list-style-type: none">●</div>
Front variable intermittent wiper	<div><ul style="list-style-type: none">●</div>	<div><ul style="list-style-type: none">●</div>

Colours		
Polar White (QM1)	<div><ul style="list-style-type: none">S</div>	<div><ul style="list-style-type: none">S</div>
Platinum (KYD)	<div><ul style="list-style-type: none">P</div>	<div><ul style="list-style-type: none">P</div>
Desert Gold (EYD)	<div><ul style="list-style-type: none">P</div>	<div><ul style="list-style-type: none">P</div>
Black Obsidian (KH3)	<div><ul style="list-style-type: none">S</div>	<div><ul style="list-style-type: none">S</div>

Warranty		
3 year/100,000kms	<div><ul style="list-style-type: none">●</div>	<div><ul style="list-style-type: none">●</div>
3 year 24-Hour Roadside Assistance Program	<div><ul style="list-style-type: none">●</div>	<div><ul style="list-style-type: none">●</div>
myNissan Capped Price Service [™]	<div><ul style="list-style-type: none">●</div>	<div><ul style="list-style-type: none">●</div>
Genuine Nissan Extended Warranty	<div><ul style="list-style-type: none">Opt</div>	<div><ul style="list-style-type: none">Opt</div>

<div><ul style="list-style-type: none">Opt</div>	<div><ul style="list-style-type: none">Optional</div>	<div><ul style="list-style-type: none">Not available</div>	<div><ul style="list-style-type: none">●</div>	<div><ul style="list-style-type: none">Standard</div>
<div><ul style="list-style-type: none">S</div>	<div><ul style="list-style-type: none">Standard paint</div>	<div><ul style="list-style-type: none">P</div>	<div><ul style="list-style-type: none">Premium paint available at extra cost</div>	

LEAF SPRING TOWBALL DOWNLOAD:

Towball Download must not exceed 250kg at GVM.^{**}To increase the towball download above 250kg, the vehicle mass needs to be decreased as per the following table.

Towball download	Vehicle Mass
250kg	GVM ^{**} (All Variants)
300kg	Reduce loaded vehicle mass below GVM ^{**} by 85kg
320kg	Reduce loaded vehicle mass below GVM ^{**} by 120kg

The vehicle mass needs to be decreased as per the following table.

COIL SPRING TOWBALL DOWNLOAD:

Towball Download must not exceed 100kg at GVM.^{**}To increase the towball download above 100kg, the vehicle mass needs to be decreased as per the following table.

Towball download	Vehicle Mass
100kg	GVM ^{**} (All Variants)
150kg	Reduce loaded vehicle mass below GVM ^{**} by 115kg
200kg	Reduce loaded vehicle mass below GVM ^{**} by 200kg
250kg	Reduce loaded vehicle mass below GVM ^{**} by 290kg
300kg	Reduce loaded vehicle mass below GVM ^{**} by 365kg
320kg	Reduce loaded vehicle mass below GVM ^{**} by 400kg

The vehicle mass needs to be decreased as per the following table.

[[]* GVM = Gross Vehicle Mass. GVM includes the driver, passengers, full fuel tank and luggage.
[#] Tare mass = unladen mass of vehicle with 10 litres of fuel, excludes tray.
[[]** Figures have been calculated in accordance with ADR81/02. Actual fuel consumption will vary depending on driving conditions, driver behavior, the condition of your vehicle and the accessories fitted.
[^] With optional wide wheels and tyres.
[†] Towing capacity is subject to towbar/towball capacity and is based on the fitment of a Genuine Nissan towbar. Towing capacity figure described is a maximum figure. Actual towing capacity depends on the laden mass of the vehicle, driving conditions, fitment of any accessories or towing equipment limitations including the maximum towball download.
[‡] iPod is a registered trade mark of Apple Inc.
[[]** Applies to the first 12x10,000kms scheduled service intervals for up to 6 years/120,000kms (whichever occurs first). Some exclusions apply. Ask your Nissan Dealer or visit nissan.com.au/cpstcs for full terms and conditions.

For more information please visit nissan.com.au/owners, ask your Nissan Dealer or phone 1800 035 035 during normal business hours.

The vehicle mass needs to be decreased as per the following table.

All illustrations, information and specifications presented and referred to in this brochure were correct at the time this brochure was approved for printing. The colours in the photographs may vary from actual colours. However, Nissan Motor Co (Australia) Pty. Ltd. reserves the right, subject to the laws of Australia and/or the regulations of any competent authority which may apply from time to time, at its discretion at anytime and without prior notice to discontinue or change the models, features, specifications, designs and prices of the products referred to in this brochure and any optional equipment therefore without incurring any liability whatsoever to any purchaser or prospective purchaser of any such products. Some of the items referred to herein are optional at extra cost. Some options may be required in combination with other options. Always consult your Nissan Dealer for the latest information on models, specifications, features, prices, options and availability. Nissan Motor Co (Australia) Pty. Ltd. AGN 004 663 156. Updated July 2013. PCC0130



**Innovation
that excites**



Follow us: @Nissan_Aus



Like us: Nissan Australia



Check out: NissanAustralia Channel

Nissan. Innovation that excites.

nissan.com.au