



PEUGEOT 308
STYLE AND SPORTIUM



PEUGEOT



THE RIGHT CHEMISTRY

WHEN YOU CHOOSE A PEUGEOT, YOU'RE BUYING MORE THAN A PIECE OF DESIGN OR A SUPERB PIECE OF ENGINEERING; YOU'RE BUYING A VISION – A MARQUE THAT EMBODIES YOUR DESIRES AND MEETS YOUR EXPECTATIONS IN EVERY WAY. A VEHICLE THAT IS THE VERY PERSONIFICATION OF THE PEUGEOT SPIRIT.

The spirit of our marque means stunning design; the very embodiment of aesthetics as seen by top Peugeot designers.

A car that makes your heart beat faster every time you look at it and drive it. Every new Peugeot is engineered to the very highest standards to achieve optimum active and passive safety, ensuring technical excellence, superb handling plus peace of mind.

It also means passion. Our passion for creating cars with real poise and precision, cars that communicate with the road and connect with you, lifting your spirits on every journey. Cars that re-awaken your enthusiasm for driving. It goes without saying that it means intelligent, innovative designs and features that answer your demands for better, safer, more comfortable and environmentally respectful vehicles. We've reduced emissions from our engines and every new car we build is at least 90% recyclable.

These are the strands of Peugeot DNA that you'll find running through every vehicle that bears our name today, and every car that we'll build tomorrow. This is Motion & Emotion.

308



THE ART OF DESIGN

How can you tell when you've achieved design excellence? When you've refined every detail until you can't improve it any further. When all the individual components come together to make one beautifully balanced whole, just as they do in the Peugeot 308. One look at its sleek V-shaped bonnet, the wide cat-like headlights, the distinctive front grille with its aerodynamic louvres and deeply recessed fog lights, and you know you are in a car of quality.





PERFECTLY POISED

Even at a standstill, the 308 looks poised, ready for action. Its perfect balance of height and length, combined with a commanding, wide track give it a purposeful stance. The taut body line running the length of its sides from the rear shoulders to the front wheel arches gives it a feeling of momentum. The pronounced, flat wheel arches and the large wheels hint at the dynamic performance to come. While from the rear, the wrap-around window and muscular sports bumper simply confirm its intentions. If you like what you see on the surface of the 308, you'll be even more impressed when you discover what lies beneath.

ENDLESS POSSIBILITIES



The spacious new 308 Sportium is versatile in more ways than one. The fact that you can rearrange the rear seating into over 50 different seating configurations including the option of 7 seats* means it fits

perfectly with any lifestyle. The body has also been designed to reflect the car's versatility, by combining a particularly expressive and dynamic design at the front with an original and curvaceous shape at the rear.

A sloping design adds elegance whilst flowing lines reinforce the impression of space and on-board comfort.



LET THE LIGHT SHINE

Beyond that, the 308 Sportium boasts some very practical features such as a panoramic glass roof and wrap-around rear windscreen which all aim to increase natural light and enhance your driving experience.

*Third row seats optional at extra cost.

THOROUGH TO THE LAST DETAIL



When we designed the interior of the 308, we wanted it to provide truly superior comfort. So one of our top priorities was to make sure that everyone had plenty of space to stretch out.

Part of our solution was to angle the dashboard by 30 degrees, freeing up space around the driver's and front seat passenger's knees. We also gave them comfortable yet

slim-backed sports seats, which created valuable extra inches of leg room for the rear passengers. But we didn't stop at giving the 308 more cabin space. To boost comfort levels even higher, we

raised the back seats – treating occupants to improved visibility.

And just to make the car feel really spacious and airy, we designed in a huge panoramic rear window.



More clever thinking went into ensuring that the interior of the 308 is a really calm place to be. We built in high levels of sound insulation. We fitted a photosensitive rear-view mirror*

to prevent the driver from being dazzled by the car behind.

The little things were big priorities too. Like making sure that there were plenty of places

to stow away all your family's bits and pieces.

We didn't want you to be left in the dark when light levels started to fall either. That's why you'll

find courtesy lights in the front and centre of the roof, as well as in the boot.

*Depending on model variant.

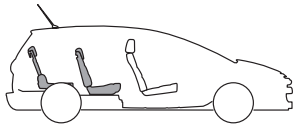

Seating

- 5 seats or up to 7 seats available as an option
- Seat backrests recline from 19 to 30° in seat row 2
- 2nd seat row comprising 3 individual sliding seats over a length of 90mm

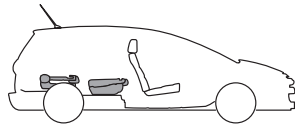

Seat shelf position

- The backrest can be folded down against the seat cushion to form a carpeted shelf
- The centre seat in the 2nd seat row, once the backrest is folded can be used as a table/shelf

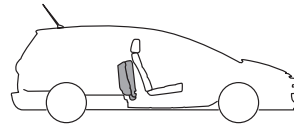

Seats folded position

- Improved load volume when the seats in the 2nd or 3rd seat row are folded down

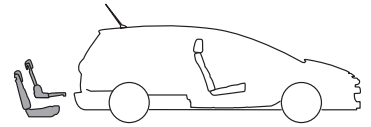

Seats removed

- Option of retaining only the driver and front passenger seats
- Optimised load volume



CREATE YOUR OWN SPACE: 308 TOURING

The 308 Touring was designed to allow you to create the environment you want. This is done by giving you the ability to re-design the inside of your car to fit your personal lifestyle requirements. The three seats in the 2nd row are independent and interchangeable, and can slide, fold away, be removed completely or even placed in the 3rd row. You also have two independent, foldable and removable 3rd row seats – perfect for when you have unexpected company.

And you will still have room for additional luggage thanks to its extremely generous boot size. The 2nd row seats also have the advantage of being able to slide over a distance of 90mm, increasing rear leg room or creating extra space in the load area, which is handy when transporting extra bulky items.





SEE DRIVING IN A NEW LIGHT



Getting into the 308 for the first time is a very enlightening experience. Not content with giving the 308 the largest expanse of window glass in its class (3.6m²), for a virtually unobscured view of the road, we've also given the 308 Touring a huge, panoramic glass roof,* which lets light flood in from outside to give you an amazing sense of freedom and space. This increases the glass area to an incredible 5.58m².

Stretching an amazing 1.68m, the roof effectively extends the stylishly raked windscreen right to the back of the passenger compartment, brightening up everyone's journey.

Worried about your passengers getting too much sunshine? Don't be. The heat reflective, tinted glass has been treated to filter out 80% of the sun's ultraviolet rays. And if the sun really starts to shine down, an electric sunblind is ready to cover up all or part of the roof at the touch of a button. There's even a thoughtful anti-pinch system to stop it operating if little fingers get in the way.

Yes, the 308 could seriously change your outlook on driving.

*Standard on all Touring models.

SETTLE DOWN IN THE DRIVING SEAT OF THE 308 AND YOU KNOW YOU'RE ON THE ROAD TO THE PERFECT DRIVING EXPERIENCE. THE 308'S RIGID CHASSIS, LOW CENTRE OF GRAVITY AND WIDE TRACK ENABLE CONFIDENT CORNERING.

THE PERFECT DRIVING PARTNER

Braking hard into a corner? You'll be pleased to know that the 308's brakes are the best in its class, featuring extra large ventilated discs on the front for more bite and endurance without a hint of vibration.

Storm clouds looming? The 308 Sportium is already ahead of you. As soon as the first drops hit, the intelligent sensor* at the top of the windscreen will activate the wipers, which speed up to match the intensity of the rain. And if the light levels start to fall too, the same sensor will turn on the headlights for you.

LED daytime running lights incorporated in the front spoiler make a bold style statement, and also help the 308 Sportium to be more visible to other road users in less-than perfect conditions.

The 308 can also see you safely to and from your door at night. The headlights stay on to light your way for a few seconds after you've used the plip key to lock the car.

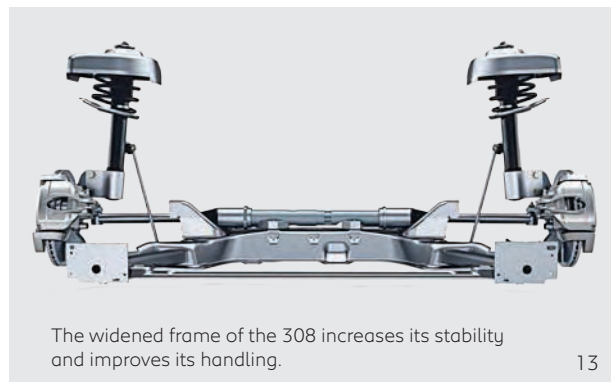
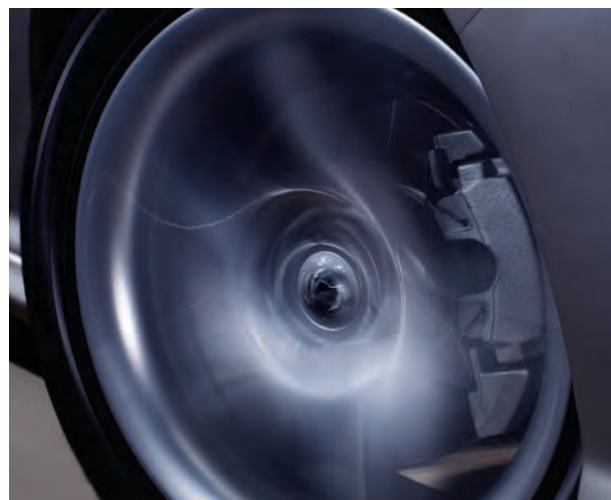

The widened frame of the 308 increases its stability and improves its handling.

*Depending on model variant.



ENGINES

PETROL

1.6L turbo 16-valve 115kW & 240Nm

The 308 Style and Sportium turbocharged petrol engine has been designed to deliver maximum performance along with optimised fuel efficiency for its cubic capacity. All offer the benefits of a 6-speed automatic transmission and variable valve timing for immediate throttle response at all speeds and in all situations.

DIESEL (Sportium only)

2.0L 16-valve HDi FAP 110/120kW & 340Nm

This advanced turbo diesel engine is coupled with a 6-speed automatic transmission and delivers effortless performance to make driving a pleasure. Fitted with Peugeot's revolutionary Particle Emission Filter (FAP) system, it is also exceptionally clean and complies with the tough Euro 5 emissions control standards.

PEUGEOT AND THE ENVIRONMENT

Peugeot offers an extensive range of low emission vehicles – more than half of its worldwide sales are of vehicles producing less than 140g of CO₂ per km. Peugeot is the leader in a range of proven technologies designed to improve environmental performance.

For example, the diesel engine combined with particle emission filter (FAP), results in a 99.99% reduction of particle emissions. Launched in 2000, this technology is now fitted in more than 2.1 million vehicles. Peugeot's breakthrough technology includes integration of the STOP & START system and the development of a new generation of HDi engines.

HDi FAP

A high-performance emission control system, the Particle Emission Filter (FAP) is combined with HDi technology. A self-cleaning system, it treats the gas resulting from the combustion of the diesel in the engine. The filter contributes to reducing the diesel particles, bringing them to the measurable limit (0.004g/km). The simple end result is a cleaner diesel engine.



CLEANER EMISSIONS

All engines in the 308 range – petrol and HDi – feature advanced technology, which allows them to meet and exceed the stringent Euro 5 emissions standard. Euro 5 is the toughest standard in force in Europe today, and easily exceeds the Euro 4 level which has been required by Australian law since July 2010.

PEACE OF MIND

At Peugeot, we don't believe you should have to take risks to have fun on the road. That's why we've spent thousands of hours developing, testing and refining the 308 to ensure it can keep its composure on even the most demanding of roads.

Our engineers gave it a wide wheel track and redesigned electro-pump steering, along with MacPherson front suspension and steel rear axle with a deformable crossmember. What does that mean on the road? Pick your favourite bends and put the 308 through its paces, you'll find it strikes the perfect balance

between solid stability and extreme agility, even at speed.

Driving in town? Then you'll find its variable, electric power assisted steering makes it easy to park and manoeuvre in heavy traffic.

As you might expect, the 308 is also equipped with a powerful, durable braking system designed to help maintain the car's composure even in difficult situations. This includes:

Anti-lock brakes (ABS) to help you keep control of the steering and prevent the car from skidding under heavy braking.

Electronic Brake force Distribution (EBD) applies a different amount of braking force to individual wheels to keep the car stable – especially if you need to brake in a corner.

Emergency Brake Assist (EBA)
Hit the brakes hard in a hurry and the system will come to your aid, applying maximum braking power in milliseconds to bring you to a halt quickly and safely. This system automatically activates the hazard lights to warn other motorists.

Electronic Stability Program (ESP), which is standard across the range comprises:

- **Traction Control (ASR)** activates the braking and engine management systems to prevent the driven wheels from spinning in slippery conditions.
- **Dynamic Stability Control (DSC)** continuously monitors and compares data from the steering wheel sensor and the yaw sensor to detect any under or oversteer, then uses the braking and engine management systems to keep you on course.

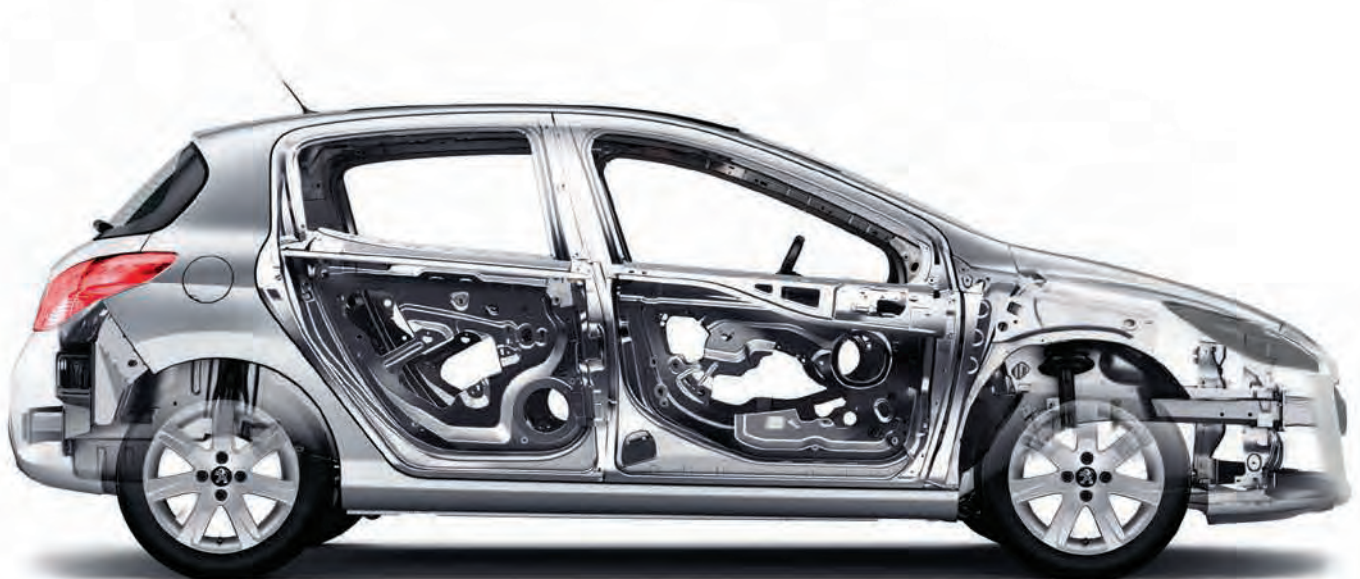

SAFETY AND STRENGTH

People come first with us. That's why we've taken all the features you can't see on the 308 as seriously as those you can. Beneath its dynamic lines lies a passenger safety cell that's been designed with three impact absorption structures to soak up as much of the crash energy as possible if you're involved in an accident. In the event of a head-on collision, you're protected by the main impact structure, as well as a new lower structure fitted onto the front subframe and extra reinforcements above the front wheel arches. So you and your passengers are effectively cocooned in a protective cell.

A further safeguard is provided by the 308's collapsible steering column, which retracts to prevent excessive injuries to the driver. The all-round protection continues with reinforced side panels to take the brunt of the force if you're hit from that angle, plus an aluminium alloy impact bar at the back to safeguard the cabin and the fuel tank.

If you do find yourself in a dangerous situation, it's reassuring to know that the 308 is fully equipped with 3-point seatbelts with force limiters, which complement the restraining effect provided by

the pretensioner in the driver and front seat passenger's belts.

The 308's final line of defence is provided by six airbags:

- Two adaptive driver and front passenger airbags for head and upper body protection, which adapt their level of inflation to match the severity of the impact.
- Two front side airbags safeguard the driver and front passengers' chests and bodies.
- Two curtain airbags, to protect both the front and rear passengers' heads.



Dimensions

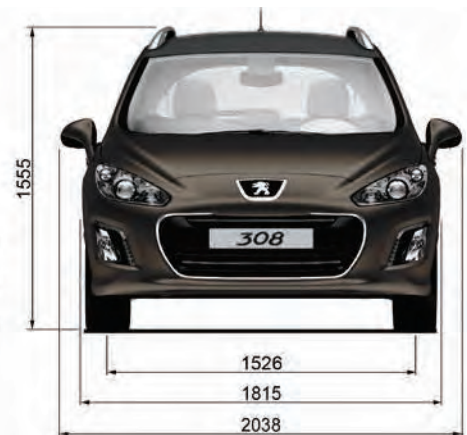
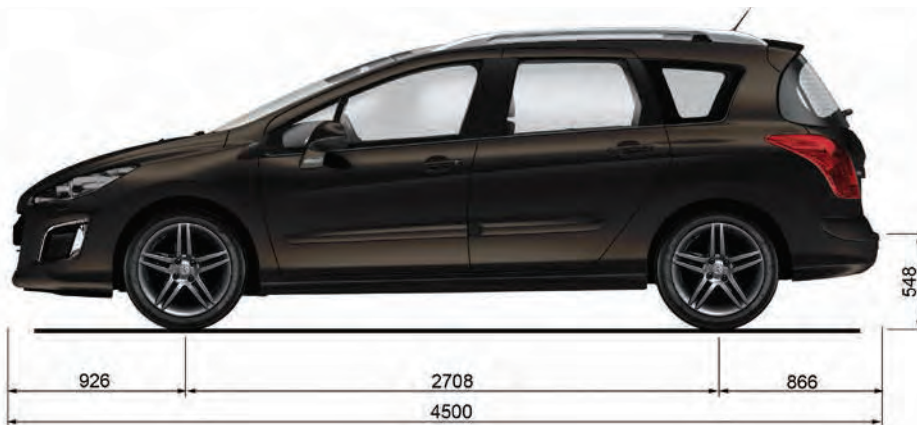
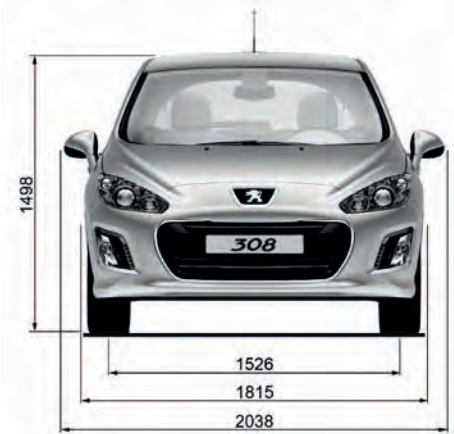
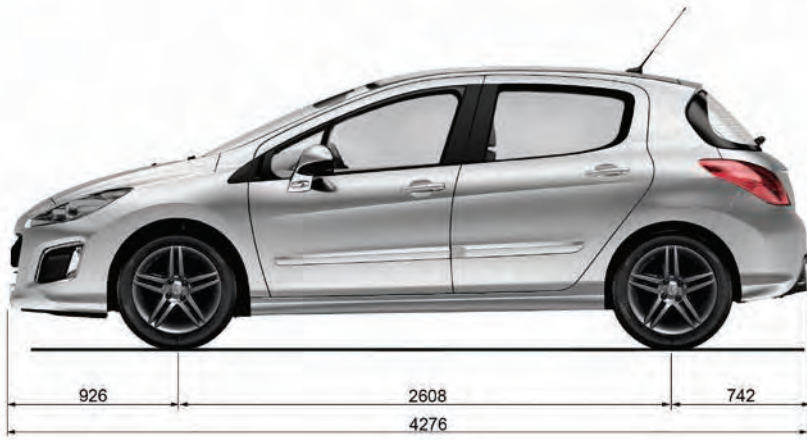

PEUGEOT AND YOU

When it comes to peace-of-mind servicing for your new 308 there is no substitute for certainty. Therefore every new 308 Style and Sportium comes with Peugeot's Assured Capped Price Servicing for 5 years or 75,000km (whichever comes first), which sets a maximum price for each of the first five scheduled service operations. Actual prices may vary from dealer to dealer, but you will not have to pay more than the applicable Capped Price. Ask your Peugeot Dealer for terms and conditions.



DRIVING DOWN THE COSTS OF SERVICING

Peugeot petrol and diesel engine cars need servicing every 15,000kms or every 12 months, whichever comes first. Technical improvements in Peugeot engine design and lubrication have been passed on, resulting in less time spent in the maintenance bay and fewer service visits. While Peugeot can predict the maintenance needs of engine and other major components, the wearing of certain components such as tyres and brake pads is less predictable and is affected by driving style and conditions. Terms and conditions apply.

3-YEAR /100,000KM WARRANTY

Should any part of the vehicle require repair or replacement as a result of a manufacturing or material defect within the warranty period, the part will be repaired or replaced completely free of charge by your authorised Peugeot dealer, regardless of any change of ownership during the period covered. The warranty does not cover items replaced during normal service and maintenance operations, which are subject to wear and tear. During the period you will also automatically receive Peugeot

Assistance cover for complete peace of mind (subject to the conditions outlined in the Warranty Maintenance Book).

12-YEAR ANTI-CORROSION WARRANTY

Peugeots are renowned for their durability and longevity. This is due in part to the sophisticated measures which are taken during the production process to optimise long-term protection from the elements. Peugeot backs this advanced technology with a 12-year warranty against corrosion-perforation of your car's bodywork – one of the longest body warranties in the world today (subject to conditions in the Warranty Maintenance Book).

PEUGEOT ASSISTANCE

Whatever it takes to get you going again, in the unlikely event of a breakdown or emergency, it only takes one free phone call. Peugeot Assistance is free for Peugeot new car owners. The programme includes 24-hour roadside assistance, vehicle recovery, technical advice, message service, home assistance and accident or theft co-ordination. Your Peugeot Dealer has full details of all terms and conditions.

PEUGEOT GENUINE PARTS PROMISE

If your car is in for a service or repair, the parts required to keep your car on the road are Peugeot genuine parts. Using specifically designed and manufactured parts ensures your Peugeot can operate at peak performance at all times.

IMPORTANT NOTICE

This is a manufacturer's advertisement. Peugeot Automobiles Australia offers this brochure as a general guide to product specifications. Photographs and illustrations in this brochure are for illustrative purposes only. The only difference between the models shown and the models available are that images shown are of left hand drive vehicles. All data in this brochure is believed to be correct as at May 2014. However, as development is an ongoing process, changes may occur from time to time, which will not necessarily be reflected herein. Therefore, Peugeot Automobiles Australia reserves the right to change specifications without notice. Accordingly, this brochure should not be regarded as an infallible guide to correct specifications, nor does it constitute an offer for sale of any particular vehicle.

Whilst all care has been taken to provide any purchaser or prospective purchaser information in regards to the general use of Peugeot products, purchasers should not rely solely on the information provided in this brochure. Purchasers or prospective purchasers should discuss individual intended purposes or use of Peugeot products with your Peugeot dealer before making a purchase decision. Dealers are not agents of Peugeot Automobiles Australia and have absolutely no authority to bind Peugeot Automobiles Australia by an express or implied undertaking or representation.

Peugeot Automobiles Australia is the trading name of Sime Darby Automobiles Pty Limited (ACN 000 426 282). Peugeot Automobiles Australia Locked Bag 206, Silverwater NSW 1811

