

VOLVO				TITLE:			GROUP:	NO:	
				Recall 155: Electronic Throttle System Software Upgrade Model Year 1999-2002 Models: C70 1999-2002 S70 1999-2000 S60 2001 all engine variants, 2002 non-turbo only. V70 1999-2001 all engine variants, 2002 non-turbo only. V70XC, 1999-2000 XC70 2001 S80 1999-2001			25	155	
Service Manager Bulletin				ISSUING DEPARTMENT:				Warranty	
				CARMARKET:				United States, Canada	
				DATE:				YEAR	MONTH
Service Person- nel: read and initial.				SERVICE MANAGER	SERVICE WRITER	WARRANTY ADMINISTRATOR	2007	01	02
				REFERENCE BULLETINS:				Page 1 of 3	
				TNN#S 25-149A-F Supersedes SMB 25-155 Dated 2006-03-20					

Service Campaign 155 is now upgraded to Recall 155. A customer mailing will be completed by the end of December to customers who have not had Service Campaign 155 performed. Repair procedures and claim submission have not changed.

BULLETIN REFERENCE

- A. RECALL 155 DESCRIPTION
- B. VEHICLES INVOLVED
- C. PARTS INFORMATION/PARTS RETURN
- D. OWNER NOTIFICATION
- E. VEHICLES IN RETAILER INVENTORY
- F. RETAILER RESPONSIBILITY
- G. RECALL REIMBURSEMENT PROCEDURES
- H. TECHNICIAN COMPETENCY REQUIREMENT
- I. RETAILER ALLOWANCE

A. RECALL 155 DESCRIPTION

An Electronic Throttle System Software Upgrade is now available for the vehicles listed above. The software upgrade contains changes that will allow the system to better differentiate between glitches or minor disturbances, and real system faults. The software upgrade will also reduce idle oscillations caused by dirt build-up in the throttle. The Electronic Throttle System software upgrade should be installed into a customer's vehicle at the first service opportunity, when the customer requests or consents to the upgrade.

"Fixed Right — First Time"



If there are no Electronic Throttle system faults in the vehicle, and the customer requests or consents to their Electronic throttle system being upgraded with the latest software, proceed to download the software as described in Tech Net Note# 25-149F. Refer to the claim submission information in this bulletin for the Software Upgrade. Vehicles with an existing Electronic Throttle System fault will require fault tracing per TNN# 25-149A to best determine if the fault will be resolved by the software upgrade.

Fault tracing and Electronic Throttle Module repairs require a separate claim per the instructions in Service Manager Bulletin 25-149. The Electronic Throttle System Software Upgrade only should be submitted per the claim instructions in this bulletin.

B. VEHICLES INVOLVED

NOTE: RETAILER MUST CONFIRM VEHICLE ELIGIBILITY PRIOR TO BEGINNING REPAIR FOR THIS RECALL.

Vehicle eligibility should be confirmed:

- Inquire via VRC² - Vehicle Warranty where the message "RECALL 155 INCOMPLETE" will appear for eligible vehicles.

All vehicles should be checked for any other incomplete recalls or service campaigns or service upgrades. All open Recall, Service Campaign or Service Upgrade repairs should be completed.

RETAILER VEHICLE RECALL LIST

"A Retailer Recall List" will be posted on VRC² in the Reports Menu under the Service Tab. This list details all affected vehicles that are on record as being retailed or currently in stock at your facility, and is updated monthly. Vehicle eligibility must be confirmed via VRC² prior to performing this recall.

C. PARTS INFORMATION / PARTS RETURN

Vehicle type and model year	Software Part #
S80 1999-2001 S60, V70 & XC70 2001 turbo engines, S60, V70 2001-2002 non-turbo engines	30785453
C70 1999-2002	30785452
S70, V70, V70 XC 1999-2000	30785451

PARTS RETURN

Parts are not required to be returned for repairs done in accordance with this recall.

D. OWNER NOTIFICATION

Announcement letters have been already mailed directly to some of the owners of the affected vehicles. These mailings will continue during the first and second quarter of 2006 to owners of the remaining affected vehicles.

E. VEHICLES IN RETAILER INVENTORY

All vehicles in retailer's inventory and qualifying for this recall should be repaired prior to a customer taking possession of the vehicle.

F. RETAILER RESPONSIBILITY

Retailers are to perform this recall on eligible vehicles regardless of mileage/kilometers or vehicle age. The recall work covered under Recall 155 is free of charge to the owner. If a customer presents a recall or service campaign letter for a vehicle that is not found via the VRC² inquiry function, please verify that the letter applies to the customer's vehicle and call the Warranty Assistance Desk at 1-800-807-7712 for instructions. If the Warranty Assistance Desk verifies that the vehicle qualifies for the Recall or Service Campaign, please perform the repair and place the recall or service campaign letter in the customer's file. Under no circumstances should a customer be denied the required service without a confirmation from VCNA/VCCL.

G. RECALL REIMBURSEMENT PROCEDURES

All claims should be submitted using the SHORT FORM application.

H. TECHNICIAN COMPETENCY REQUIREMENT

The technician competency requirement for this recall repair is: Level 2.

I. RETAILER ALLOWANCE

Parts and labor reimbursement amounts are effective at time of release and may change in the future.

<u>Claim Type</u>	<u>Repair Code</u>	<u>Repair Description</u>	<u>Labor Time</u>
S25045	02	Software Download part # 30785453	0.3
S25045	03	Software Download part # 30785452	0.3
S25045	04	Software Download part # 30785451	0.3

Tech-Net Notes

"Fixed Right – First Time"

Volvo Technicians, Service and Parts Managers

NO:	25-149-A
DATE:	01-02-2007
MODEL/YEAR:	C70 1999-2002 S70 1999-2000 S60 2001 all engine variants, 2002 non-turbo only. V70 1999-2001 all engine variants, 2002 non-turbo only. V70XC, 1999-2000 XC70 2001 S80 1999-2001
SUBJECT:	Recall 155 - Troubleshooting Electronic Throttle System (ETS)
REFERENCE:	VIDA

This Tech Net Note supersedes the previous TNN 25-149A dated 07-07-06. Please update your files.

The two prior versions of this TNN offered background and fault tracing information for the Electronic Throttle System on the above vehicles. With the release of VIDA version 2006B the background and fault tracing information has been integrated into VIDA.

New Fault Tracing

The fault tracing for ETS codes in VIDA has been enhanced to include more background information on Faults sub system and the criteria for detecting a fault. Where applicable if there are differences between the original software's fault detection criteria and the new ETS software (March 2006 and later) the differences are described in the fault code information.

Design and Function

The Design and function section of VIDA described as "Throttle Diagnostic" has been enhanced significantly and offers an excellent description of the system and all of the involved components, including the interaction of and dependence between components for system function. This is worth reading as a refresher on the functionality.

Potentiometer Tool

Some of the ETS DTCs (9150, 9160, 91A7) may indicate that the signal value from the throttle position sensors was incorrect. One possible source for this fault is wear or aging of the potentiometers themselves. From VIDA 2006B, when following the fault tracing for these DTCs, the information suggests testing the potentiometers if counter 4 is higher than 10. The tool can be accessed by clicking the VCT symbol from the fault tracing, or by looking under the advanced tab for the ETM / Vehicle Communication. The tool will sweep the throttle potentiometers, closed-open-closed, four times while displaying the difference in values between the potentiometers.

The tool will only work with the latest ETM software, so it will need to be downloaded before the potentiometers can be evaluated. Please read the text in the test tool dialogue box carefully the first time to understand the ignition key and button combination needed to start the test. For VIDA 2006B, the test box will always have the wrong message along the bottom telling you the software needs to be upgraded, even if it has already been upgraded. Ignore this message. DTCs may need to be erased after the ETM has been allowed to re-set.

Combined Fault Code Matrix

As with the TNN, the fault tracing in VIDA now has links from the individual DTCs to a combined Fault Code Matrix, to enable root cause DTCs to be determined. The following statement:

"Of the above diagnostic trouble codes (DTC's), only the Electronic throttle module (ETM) can be a possible cause for the following diagnostic trouble codes (DTC's): 903F, 910E, 914F, 9150, 9160, 91A7, 91B7, 91F0."

was translated incorrectly and should be ignored, there are many possible root causes for these DTC's and the fault tracing should be followed.

Software Part Number Identification

In VIDA 2006B, guidance is given to identify the latest ETS software as a part of most of the fault tracing steps. However, due to the long lead times involved in publishing the VIDA information, the part numbers used for the turbo and 6-cylinder non-turbo vehicles are incorrect. (See below.)

From July 1st there will be a small change to the engine management software released for the turbo and 6-cylinder non-turbo vehicles as part of the ETS upgrade. In the initial versions released in March, 2006, a change was made to the idle air adaptation to better compensate for aging and normal dirt build-up in the throttle over time. Unfortunately, when the air adaptation was expanded, the initial value (starting point) was left as it was in the original software.

This may in some cases mean that a vehicle with a dirty throttle and/or breather system would require some adaptation by the technician to eliminate a surging idle before giving the vehicle back to the customer. This would also be necessary if the battery was disconnected or if any fault codes were cleared from the ECM; clearing the fault codes also clears adaptation values. To aid the technician in expediting ETS upgrades, from July 1st 2006 the ECM software component for these vehicles has the initial value for the air adaptation set to the median value, reducing the need for adaptation.

Upgrading to this later version may also help a customer who regularly disconnects the vehicle battery for storage.

Due to the software revision above, the software part numbers for the affected engine management systems have changed. The latest (after July 1st 2006) software can best be identified using the diagnostic part numbers in the Matrix below. ECM software downloaded to all turbo and 6-cylinder non-turbo engines between 3/17/2006 and 7/1/2006 can be identified by the software part number in the matrix below.

S70/V70 XC/V70 (-00)/C70 Turbocharged models.

ETM – 1999- 30785388 - Diagnostic software part number

ECM - 1999: 30785205 –software part number

ECM - 1999: 30785206 –software part number

ECM - 1999: 30785207 –software part number

ECM - 1999: 30785208 –software part number

ECM - 1999: 30785209 –software part number

ECM – 1999: 30785372 - Diagnostic software part number

All model year 1999 software's downloaded after July 1st can be identified using only the diagnostic part number above.

ECM – 2000 30785212 –software part number

ECM – 2000 30785213 –software part number

ECM – 2000 30785214 –software part number

ECM – 2000 30785215 –software part number

ECM – 2000 30785216 –software part number

ECM – 2000 30785217 –software part number

ECM – 2000 30785218 –software part number

ECM – 2000 30785221 –software part number

ECM – 2000 30785222 –software part number

ECM – 2000 30785223 –software part number

ECM – 2000 30785224 –software part number

ECM – 2000- 30785373 - Diagnostic software part number

All model year 2000 software's downloaded after July 1st can be identified using only the diagnostic part number above.

ECM – 2001 30785235 –software part number

ECM – 2001 30785236 –software part number

ECM - 2001 30785237 - software part number

ECM - 2002 30785238 - software part number

ECM - 2002 30785239 - software part number

ECM - 2002 30785240 - software part number

ECM - 2001/2- 30785373 - Diagnostic software part number

All model year 2001/2 software's downloaded after July 1st can be identified using only the diagnostic part number above.

S60/V70 (00-)/V70 XC(01-)/XC70/S80 5 cylinder turbo & all 6 cylinder.

ETM - 1999- 30785388 - Diagnostic software part number

5 cyl turbocharged engine

ECM - 2000 30785225 - software part number

ECM - 2000 30785226 - software part number

ECM - 2000 30785227 - software part number

ECM - 2000 30785228 - software part number

ECM - 2000 30785375 - Diagnostic software part number

All model year 2000 software's downloaded after July 1st can be identified using only the diagnostic part number above.

ECM - 2000- 30785229 - software part number

ECM - 2000- 30785230 - software part number

ECM - 2000- 30785231 - software part number

ECM - 2000- 30785232 - software part number

ECM - 2000- 30785376 - Diagnostic software part number

All model year 2000 software's downloaded after July 1st can be identified using only the diagnostic part number above.

6 cyl engines

ECM - 1999 30785203 - software part number

ECM - 1999 30785204 - software part number

ECM - 1999 30785210 - software part number

ECM - 1999 30785211 - software part number

ECM - 1999 30785377 - Diagnostic software part number

All model year 1999 software's downloaded after July 1st can be identified using only the diagnostic part number above.

ECM - 2000 30785219 - software part number

ECM - 2000 30785220 - software part number

ECM - 2000 30785378 - Diagnostic software part number

All model year 2000 software's downloaded after July 1st can be identified using only the diagnostic part number above.

ECM - 2000- 30785233 - software part number

ECM - 2000- 30785234 - software part number

ECM - 2000- 30785376 - Diagnostic software part number

All model year 2000 software's downloaded after July 1st can be identified using only the diagnostic part number above.

S70/V70 (-00) Non turbo
ETM – 1999- 30785387 –Diagnostic part number. ECM - 1999: 30785131 –Diagnostic part number. ECM - 2000 30785132 –Diagnostic part number.
S60/V70 (00-) Non turbo
ETM – 1999- 30785387 –Diagnostic part number. ECM - 2001 30785129 –Diagnostic part number. ECM - 2002- 30785130 –Diagnostic part number.

VOLVO for life,
Volvo Cars of North America, LLC

Please circulate, read and initial: _____ Svc Mgr _____ Parts Mgr _____ Shop Foreman

_____ TECHS

_____ Warranty Administrator _____ S. Advisors

Tech-Net Notes

"Fixed Right – First Time"

Volvo Technicians, Service and Parts Managers

NO: 25-149-B
DATE: 01-02-2007
MODEL/ YEAR: C70 1999-2002
S70 1999-2000
S60 2001-2002
V70 1999-2002
V70XC 1999-2001
S80 1999-2001
SUBJECT: Recall 155 - Checking Crankcase Ventilation System
REFERENCE: VIDA STB-148

This Tech Net Note supersedes the previous TNN 25-149A dated 02-20-06. Please update your files.

DESCRIPTION:

This TNN describes a new method for checking the functionality of crankcase ventilation.

Special tool	Part No
Gauge (manometer) See Special Tool Bulletin 148	999 7226

SERVICE:

Crankcase ventilation check

1.

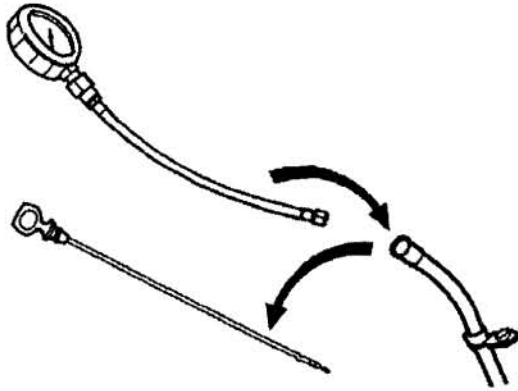

i-229247

Measuring pressure in the crankcase

Measure with the engine:

- At Operating temperature (Fully warmed up).
- With the engine running at idle speed.
- With the A/C Off.
- With all Electrical Accessories off (Heated seats, Lights etc.)

The Battery and Charging system must be in good condition.

Note! Specification given is for Sea Level, (Higher Altitude will reduce the vacuum reading slightly).

Remove the dipstick and connect the pressure gauge (manometer) 999 7226 as illustrated.

2.

Measuring pressure in the crankcase 5-cyl Turbo and 6-cyl Turbo

Read the value on the gauge:

The value for clean crankcase ventilation is -0.2 kPa or lower.

If the gauge shows a value of -0.2 to 0.0 kPa or a positive value, The crankcase ventilation is partially or fully clogged and must be cleaned as described in:

TNN 25-149-C, Cleaning the Crankcase Ventilation.

Note:

The gauge should not be used to verify the cleaning of the crankcase ventilation hose and banjo fitting.

The gauge reading may also be affected by other conditions in the engine like a leaking oil filler cap gasket, and should only be used as an indication that further diagnosis should be performed.

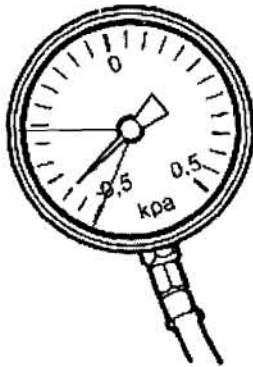

i-229257

3.

Measuring pressure in the crankcase

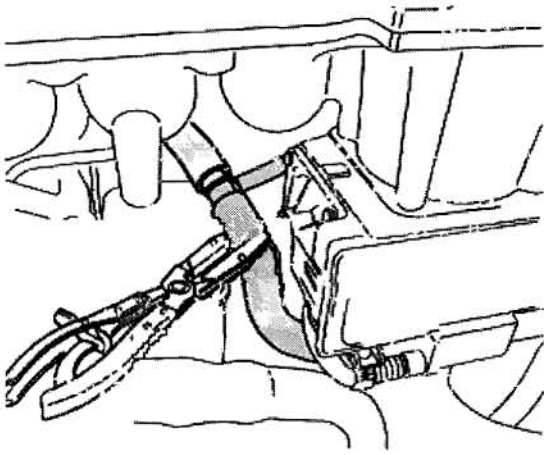

6-cyl Non-turbo

Read the value on the gauge:

The value should read approximately 0.0 kPa.

Gently squeeze the hose between the "T" fitting and the intake hose using a hose clamp pliers similar to the ones shown in the illustration.

Note:

Be careful not to close off the hose completely because this will damage the gauge.

If negative pressure can be seen on the gauge the crankcase ventilation is clean and no further work is needed.

If no or very little negative pressure is seen, the crankcase ventilation is partially or fully clogged and must be cleaned as described in:

TNN 25-149-C, Cleaning the Crankcase Ventilation.

Note:

The gauge should not be used to verify the cleaning of the crankcase ventilation hose. The gauge reading may also be affected by other conditions in the engine like a leaking oil filler cap gasket, and should only be used as an indication that further diagnosis should be performed.

i-229257

VOLVO for life,
Volvo Cars of North America, LLC
Technical Service

Please circulate, read and initial: _____ Svc Mgr _____ Parts Mgr

_____ TECHS

_____ Shop Foreman _____ Warranty Administrator

Tech-Net Notes

"Fixed Right - First Time"

Volvo Technicians, Service and Parts Managers

NO: 25-149-C
DATE: 01-02-2007
MODEL/YEAR: C70 1999-2002
S70 1999-2000
S60 2001
V70 1999-2001
V70XC 1999-2001
S80 1999-2001
SUBJECT: Recall 155 - Cleaning the Crankcase Ventilation
REFERENCE: SMB 25-155, VIDA, TNN 25-149-B

This Tech Net Note supersedes the previous TNN 25-149C dated 02-20-2006. Please update your files.

DESCRIPTION:

This TNN is an update of the existing method for cleaning the crankcase ventilation system shown in SB 25-0035 February 2004.

Material C70 1999-2002 S70/V70 1999-2000 V70XC 1999-2000 5-cyl Turbo

Description	Quantity	Part Number
Gasket	2	947282
Cable tie	1	983750

Material S60 2001 V70 2001 V70XC 2001 5-cyl Turbo

Description	Quantity	Part Number
Gasket	2	947282
O-ring	1	969092
Cable tie	1	983750

Material 6-cyl Turbo

Description	Quantity	Part Number
Gasket	2	947282

Material 6-cyl Non-turbo

Description	Quantity	Part Number
-------------	----------	-------------

Gasket

1

9440982

Special Tool

Description

Wrench (B5T) See Special Tool Bulletin 143

Protection (B6S) See Special Tool Bulletin 114

Part Number

999 7109

999 5723

SERVICE:

Crankcase Ventilation, Cleaning

Cleaning, 5-cyl Turbo

1.

Note! The method applies to both the C70 1999-2002 S70/V70 1999-2000 V70XC 1999-2000 and S60 2001 V70 2001 V70XC 2001. Certain parts of the method differ but this is stated in the heading for that stage.

Remove:

- the battery negative lead from the battery, see:
Electrical system
Battery replacement
- the auxiliaries belt. Use wrench 999 7109
- cold air inlet hose to the control module if applicable.

2.

Only S60 2001 V70 2001 V70XC 2001

Remove:

- the screw for the charge air pipe over the engine
- the clamp for the power steering pump pressure pipe from the intake manifold
- the charge air hose from the charge air cooler (CAC).

Move the charge air pipe with hose to one side.

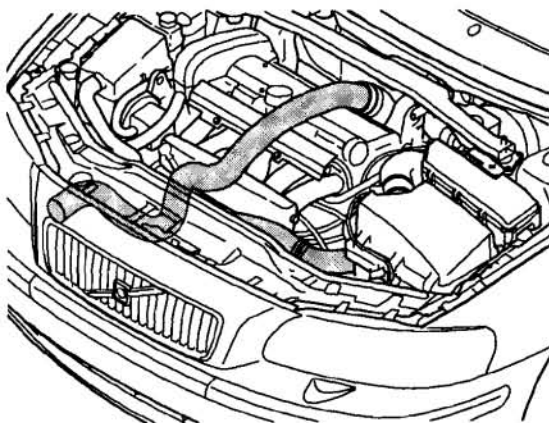

M2600265

3.

If the vehicle has locking brackets

Remove:

- the locking bracket (2) by removing the screw (1)
- the pipe nipple by the pump.

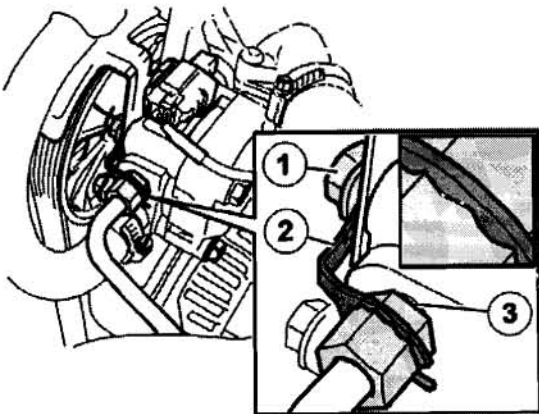

D6400800

4.

Only S60 2001 V70 2001 V70XC 2001

Place paper towels under the power steering pump to absorb any oil from the power steering pump.

Install hose clips on the hose to the power steering pump.

Remove the delivery line from the power steering pump. Plug the power steering pump and the power steering pipe using rubber plugs.

Remove the connector from the belt protector above the power steering pump.

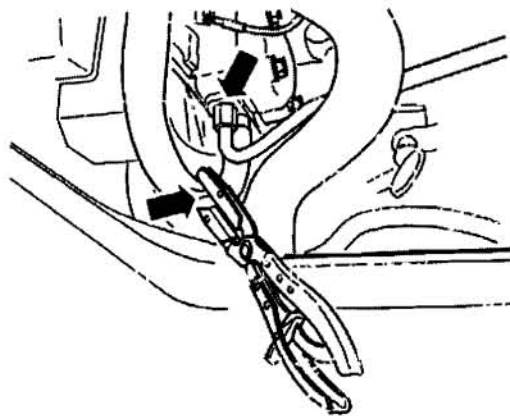

i-229918

5.

Remove the power steering pump's 3 x mounting screws through the pulley hole.

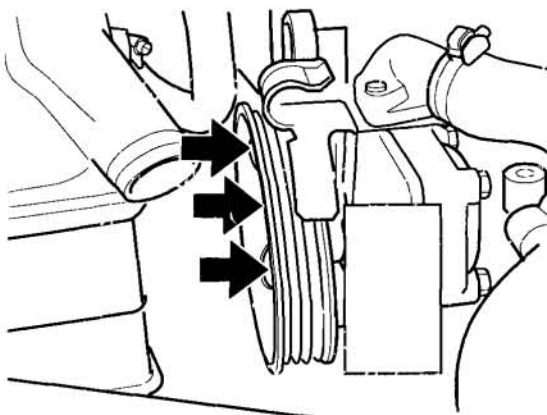

N6400614

Only S60 2001 V70 2001 V70XC 2001

Remove the power steering hoses and coolant hoses from their holders/clips). Remove the tie strap for the power steering hose by the suspension turret.

Remove:

- the coolant expansion tank and the power steering reservoir from the mounting on the spring strut turret
- the connector and place the reservoirs on the engine.

Place the power steering pump up on the engine.

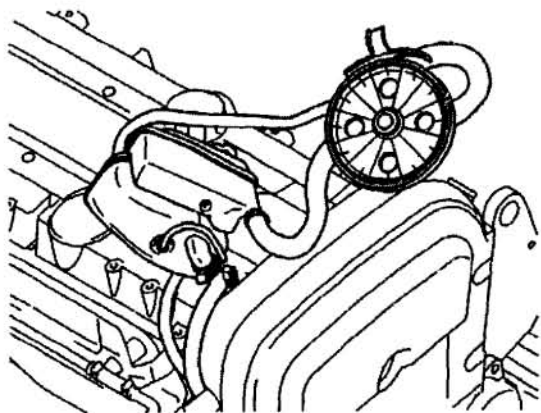

i-229917

Only S60 2001 V70 2001 V70XC 2001**Remove:**

- power steering hoses and coolant hoses from their holders/clips. Remove the tie strap for the power steering hose by the suspension turret
- the power steering reservoir from its mounting on the coolant expansion tank
- the connector and place the power steering reservoir on the engine.

Place the power steering pump up on the engine.

Removing the alternator

Remove:

- the upper screw for the alternator
- screws common to the alternator and compressor.

Loosen the lower screws for the compressor (so that there is some clearance).

Position the alternator so that it rests against the radiator and on the air conditioning (A/C) compressor.

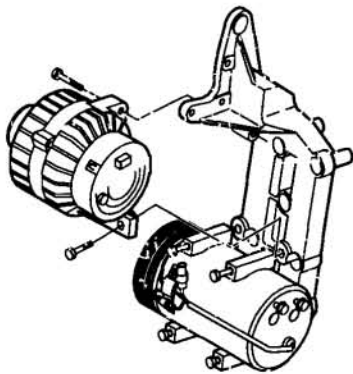

D3200C73

Cleaning the crankcase ventilation

Remove the banjo bolt from the intake manifold.

Remove the hose (1) from the banjo nipple.

Remove the oil filler cap.

Blow the hose clean (1) using compressed air (2) to verify that the system is open.

If the hose is blocked clean the hose using 2.0 mm diameter wire.

If air travels through to the oil filler the breather is good, no further verification or repairs are necessary.

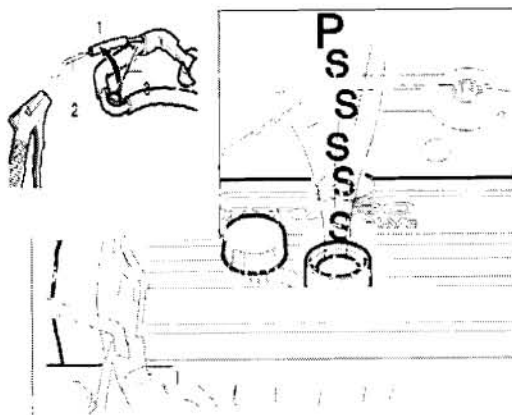

Note! If the hose is blocked, use a welding rod (maximum \varnothing 2.0mm, approximately 250 mm long) to unblock the hose.

Clean the banjo nipple using a \varnothing 2.0 mm drill bit (3).

Install:

- the hose on the banjo nipple
- the banjo bolt with new gaskets
- the oil filler cap.

Raise the car.

Remove the splashguard under the engine

Tighten the banjo bolt. Tighten to 24 Nm.

Install the cover under the engine.

Lower the car.

Installing the alternator

Install:

- the alternator in the correct position
- the upper screw but do not tighten
- the screws common to the alternator and the air conditioning (A/C) compressor. Do not tighten.

Tighten.

- the upper screw. Tighten to 24 Nm
- the lower screws for the air conditioning (A/C) compressor. Tighten to 24Nm
- the screws common to the alternator and the air conditioning (A/C) compressor. Tighten to 24 Nm.

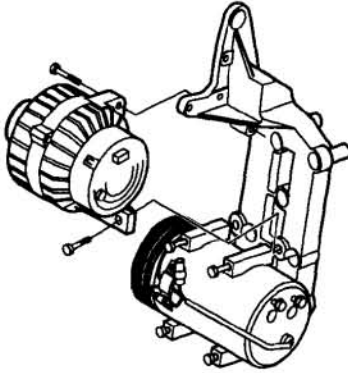

D3200073

Installing the power steering pump

Install:

- the power steering pump in the correct position
- the 3 x screws through the pulley. Tighten to 24 Nm.

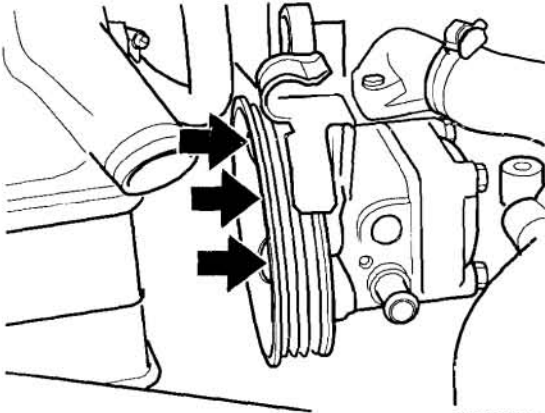

N6400614

Only S60 2001 V70 2001 V70XC 2001

Install the delivery line on the power steering pump. Use new O-rings on the delivery line. Tighten to 25 Nm.
Remove the hose clip.

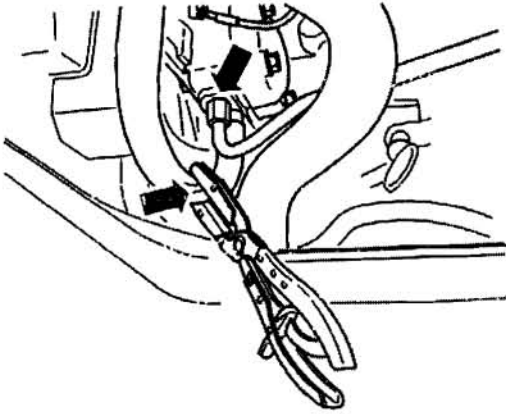

i-229918

12.

Only S60 2001 V70 2001 V70XC 2001

Note! If the vehicle has locking brackets.

Install the locking bracket (2).
Tighten the screw (1). Tighten to 24 Nm.

Note! There may be a gap (3) of a few millimeters between the pipe coupling and the power steering pump. Bend the bracket so that the twelve edged mounting on the bracket is on the nut.

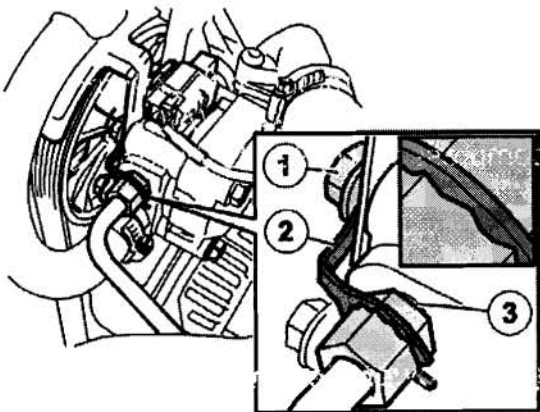

D6400800

13.

Only S60 2001 V70 2001 V70XC 2001

Install:

- the auxiliaries belt. Use Wrench 999 7109
- the connector with holder on the power steering pump
- the power steering reservoir in its mounting on the expansion tank
- the hoses in their holders and clips
- the tie strap for the servo hose by the suspension turret.

14.

Only C70 1999-2002 S70/V70 1999-2000 V70XC 1999-2000

Install:

- the auxiliaries belt. Use Wrench 999 7109
- the connector for the coolant level sensor
- the coolant reservoir and the power steering reservoir in their mountings
- the hoses in their holders and clips
- the cold air inlet hose to the control module

Turn the ignition key to position 2
Connect the battery negative lead.

15.

Only S60 2001 V70 2001 V70XC 2001

Install:

- the charge air hose on the charge air cooler (CAC).
- the screw for the charge air pipe above the engine and clamp for the power steering pump delivery line from the intake manifold.
- the cold air inlet hose to the control module.

Check the level in the power steering reservoir and top up if necessary.
Turn the ignition key to position 2
Connect the battery negative lead.
Start the engine and check for leaks.

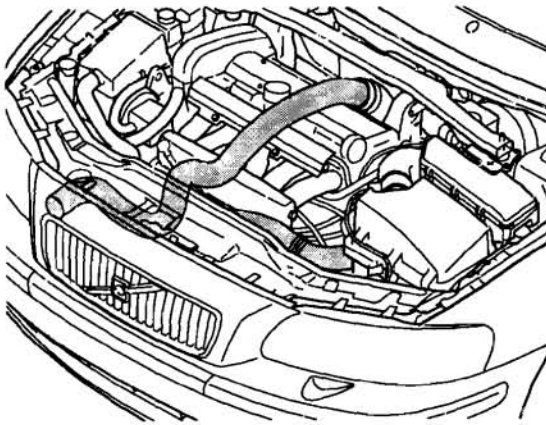

M2600265

Cleaning, 6-cyl Turbo

16.

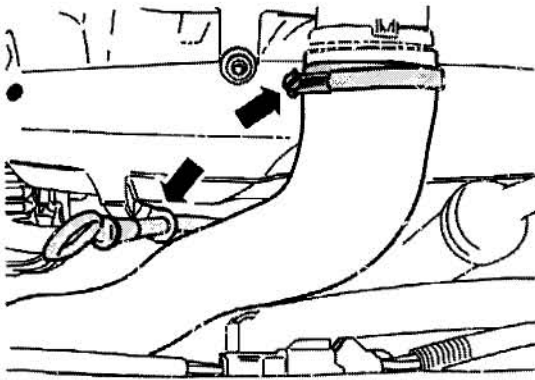

i-227101

Remove the oil dipstick pipe to facilitate access.

Remove the charge air hose from the charge air pipe.

The banjo nipple is located underneath the intake manifold, behind the mounting for the oil dipstick pipe.

Cleaning the crankcase ventilation

Remove the banjo bolt from the intake manifold.

Remove the hose (1) from the banjo nipple.

Remove the oil filler cap.

Blow the hose clean (1) using compressed air (2) to verify that the system is open.

If the hose is blocked clean the hose using 2.0 mm diameter wire.

If air travels through to the oil filler the breather is good, no further verification or repairs are necessary.

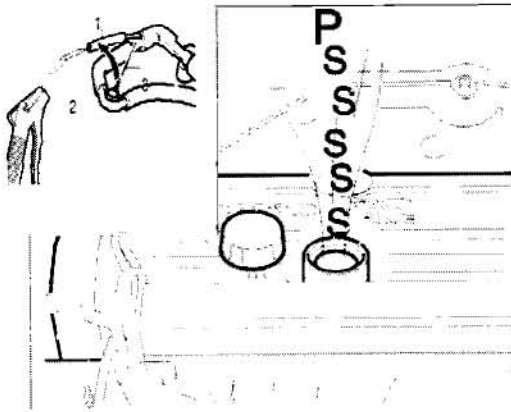

Note! If the hose is blocked, use a welding rod (maximum Ø 2.0mm, approximately 250 mm long) to unblock the hose.

Clean the banjo nipple using a Ø 2.0 mm drill bit (3).

Install:

- the hose on the banjo nipple
- the banjo bolt with new gaskets
- the oil filler cap.

Raise the car.

Remove the splashguard under the engine

Tighten the banjo bolt. Tighten to 24 Nm.

Install the cover under the engine.

Lower the car.

17.

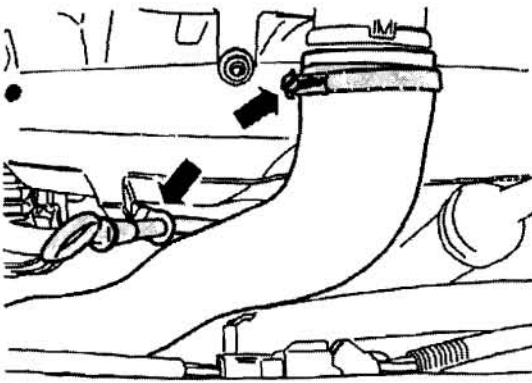

i-227101

Install:

- install the dipstick oil pipe
- the charge air hose to the charge air pipe.

Cleaning, 6-cyl Non-turbo

18.

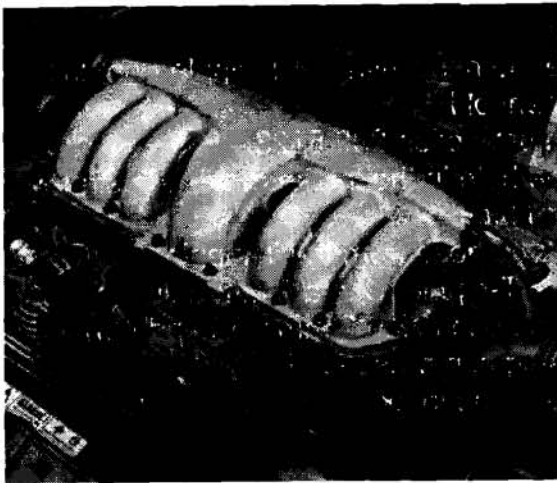

S2101328

Cleaning

Remove the ten screws by the intake manifold's mating flange.
Lift off the upper section of the intake manifold.
Install the protection 999 5723.

19.

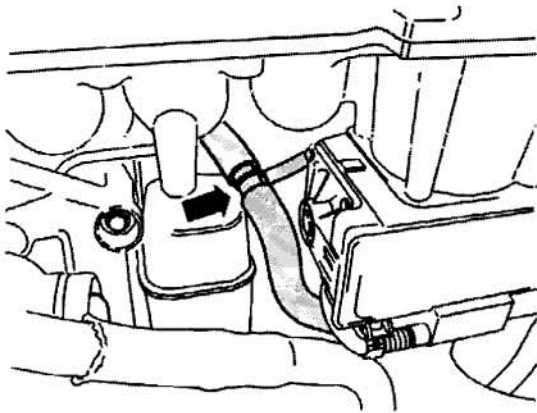

i-227102

Remove:

- the oil dipstick pipe
- the two thick hoses from the T-nipple.

20.

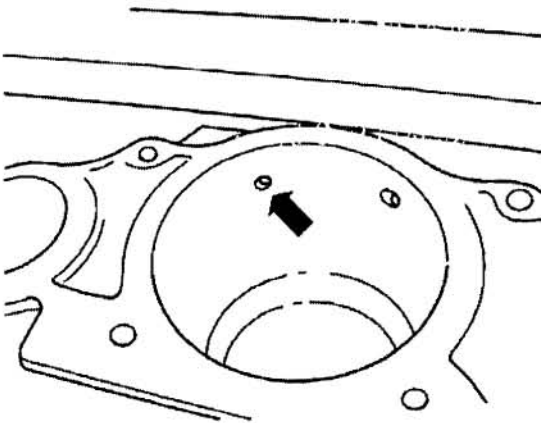

i-230583

Remove the hose with the T-nipple from the intake manifold.

Remove protection 999 5723.

Clean the hole in the intake manifold using a 2 mm drill bit.

Remove the hose from the T-nipple.

Clean the T-nipple. Use a 2 mm drill bit.

Clean the hose using 2 mm wire and blow clean using compressed air.

Wipe clean the intake manifold's air duct.

Install:

- the hose on the T-nipple
- the hose with the T-nipple to the intake manifold
- protection 999 5723.

21.

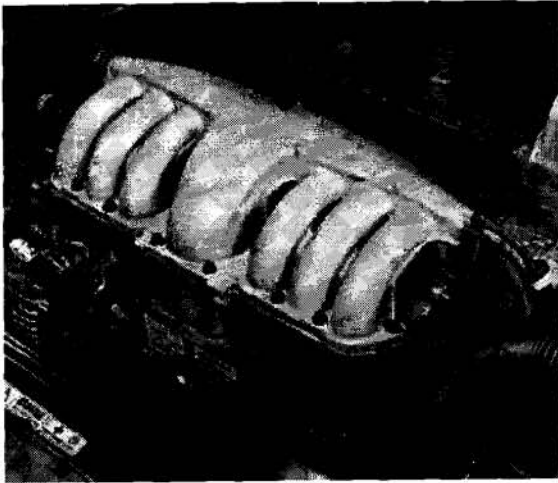

S2101328

Remove protection 999 5723.

Install:

- new gasket
- the upper section of the intake manifold. Tighten the screws from the inside out alternately. Tighten to 17 Nm.

22.

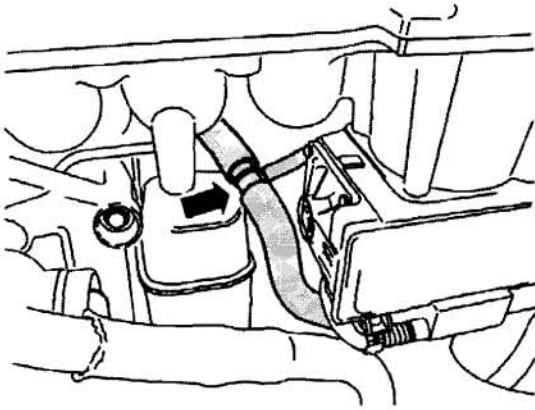

i-227102

Install:

- the two thick hoses to the T-nipple

Note! The T-nipple's thickest coupling to the flame trap.

- the oil dipstick pipe.

VOLVO for life,
Volvo Cars of North America, LLC
Technical Service

Please circulate, read and initial: _____ Svc Mgr _____ Parts Mgr

TECHS

Shop Foreman Warranty Administrator

Tech-Net Notes

"Fixed Right – First Time"

Volvo Technicians, Service and Parts Managers

NO: 25-149D
DATE: 01-02-2007
MODEL/YEAR: C70 1999-2002
S70 1999-2000
S60 2001-2002
V70 1999-2002
V70XC 1999-2001
S80 1999-2001
SUBJECT: Recall 155 - Cleaning the Crankcase Ventilation and Electronic Throttle Module (ETM)
REFERENCE: SMB 25-155, VIDA, TNN 25-149-B

This Tech Net Note supersedes the previous TNN 25-149D dated 12-06-2005. Please update your files.

DESCRIPTION:

This TNN describes the method for cleaning the Crankcase Ventilation and Electronic Throttle Module (ETM). Cleaning must always be preceded by fault-tracing according to Vida and TNN 25-149- A.

S60/V70 (00-)/V70XC (01-)/S80 5-cyl Turbo

Material

Description	Quantity	Part Number
Gasket	2	947282
Gasket	1	8636753
O-ring	1	969092
Cable tie	1	983750
Cable tie	2	983662
Cable tie	3	983614
Cleaner	1	1161828

C70/S70/V70XC 5-cyl Turbo

Material

Description	Quantity	Part Number
Gasket	2	947282
Gasket	1	8636753
Cable tie	1	983750
Cleaner	1	1161828

6-cyl Turbo**Material**

Description	Quantity	Part Number
Gasket	2	947282
Gasket	1	8636753
Cleaner	1	1161828

6-cyl Non-turbo**Material**

Description	Quantity	Part Number
Gasket	1	9440982
Gasket	1	8636753
Cleaner	1	1161828

Special tool

Description	Part Number
Wrench (B5T)	999 7109
Protection (B6S)	999 5723

Crankcase ventilation and electronic throttle module (ETM), 5-cyl, cleaning

1.

Cleaning the crankcase ventilation, 5-cyl Turbo

Note! The method applies to the S60/V70 (00-)/V70XC (01-)/S30.

Remove:

- the battery negative lead from the battery. When removing and installing the battery leads. See: Electrical system
Battery replacement
- the auxiliaries belt. Use wrench 999 7109.
- cold air inlet hose to the control module if applicable.

2.

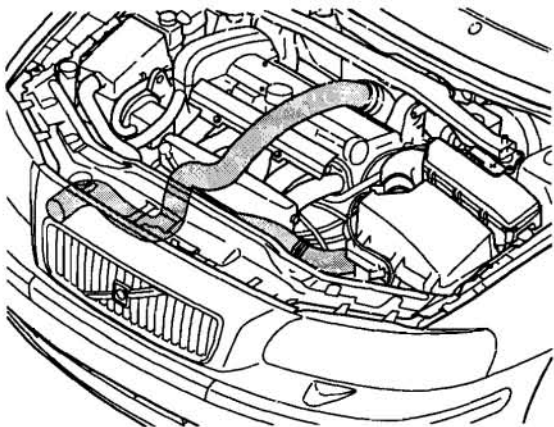

Remove the oil dipstick pipe.

Remove:

- the screw for the charge air pipe over the engine
- the clamp for the power steering pump pressure pipe from the intake manifold
- the charge air hose from the charge air cooler (CAC)
- the charge air pipe from the hose on the turbo.

Remove the charge air pipe.

M2600265

3.

If the vehicle has locking brackets

Remove:

- the locking bracket (2) by removing the screw (1)
- the pipe nipple by the pump.

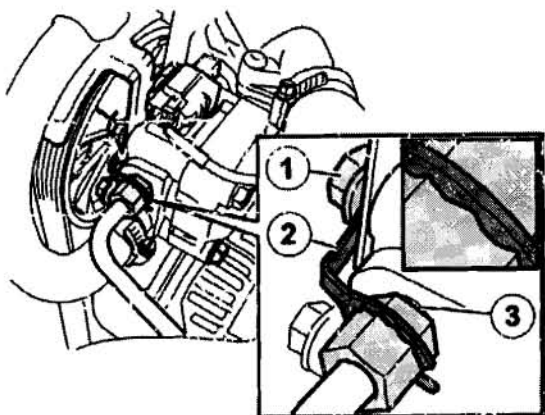

D6400800

4.

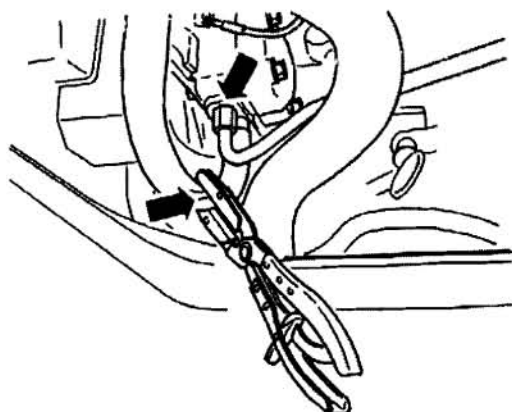

Place paper towels under the power steering pump to absorb any oil from the power steering pump.

Install hose clips on the hose to the power steering pump.

Remove the delivery line from the power steering pump. Plug the power steering pump and the power steering pipe using rubber plugs.

Remove the connector from the belt protector above the power steering pump.

i-229918

5.

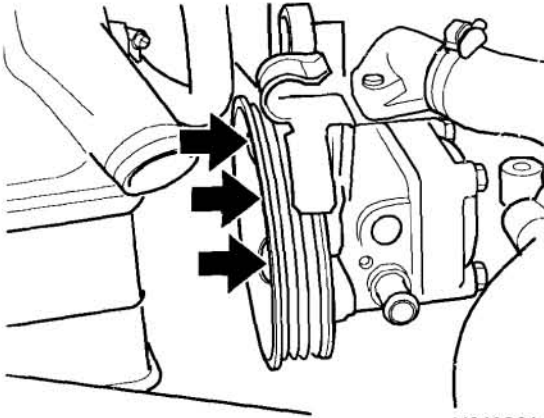

N6400614

Remove the power steering pump's 3 x mounting screws through the pulley hole.

6.

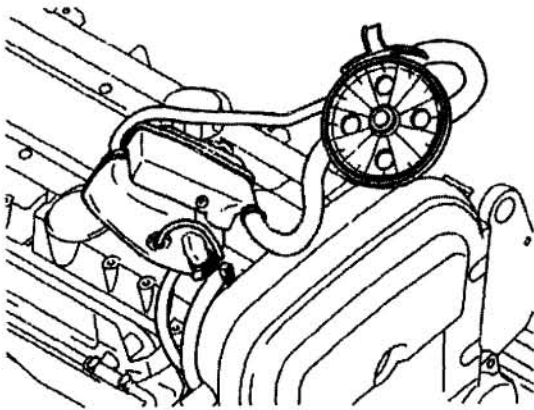

Remove:

- power steering hoses and coolant hoses from their holders/clips. Remove the tie strap for the power steering hose by the suspension turret
- the power steering reservoir from its mounting on the coolant expansion tank
- the connector and place the power steering reservoir on the engine.

Place the power steering pump up on the engine.

7.

Removing the alternator

Remove:

- the upper screw for the alternator
- the screws common to the alternator and compressor.

Loosen the lower screws for the compressor (so that there is some clearance).

Position the alternator so that it rests against the radiator and on the air conditioning (A/C) compressor.

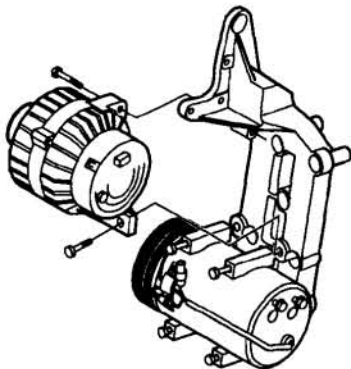

D3200073

8.

Removing the fan shroud

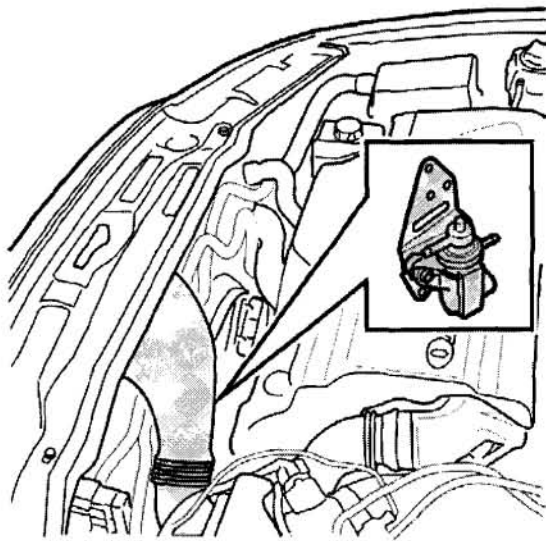

Remove the intake manifold for the air cleaner (ACL) housing.
Disconnect both the connectors for the engine cooling fan.

Remove:

- the canister purge (CP) valve from the fan shroud for the engine cooling fan
- the four tie straps holding the cable harness by the fan shroud.

Note! Certain cars have three tie straps and one clip that hold the cable harness by the fan shroud.

Lift out the hose for the expansion tank from the holders on top of the fan shroud.
Remove both the screws holding the fan shroud.
Carefully lift up the engine cooling fan (FC).

D2600258

9.

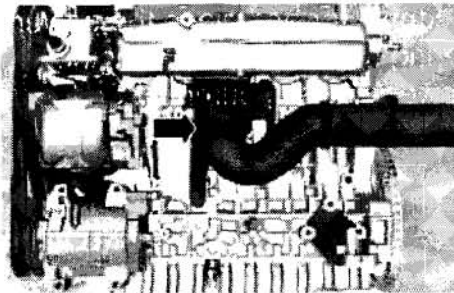

I-230280

Loosen the hose clamp for the charge air pipe on the electronic throttle module (ETM).
Remove the charge air pipe from the electronic throttle module (ETM).

10.

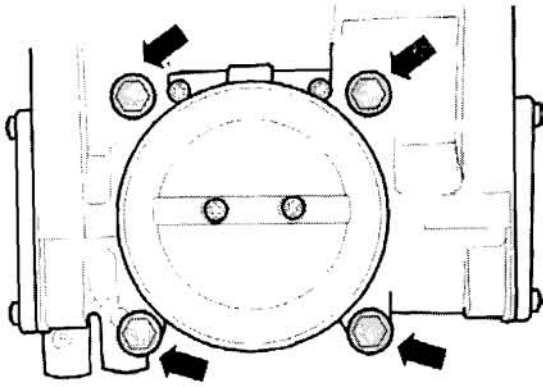

i-230120

Remove the 4 x screws for the electronic throttle module (ETM).

11.

Cleaning the electronic throttle module (ETM)

Raise the electronic throttle module (ETM) and place it between the radiator and the intake manifold.

Place paper under the electronic throttle module (ETM).

Clean the throttle and bore as follows.

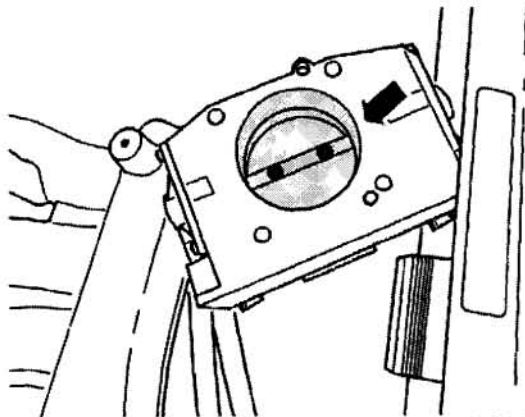

i-230121

Note! Do not use compressed air when cleaning the electronic throttle module (ETM).

2

Cleaning the ETM

Warning! DO NOT submerge throttle unit in cleaning solvent. ONLY use cleaning solvent recommended in this bulletin.

Important! Do not scrape or use a rotary wire brush to clean the unit.

Clean the ETM bore using cleaner (P/N 1161828) and a soft bristle brush.

Ensure that all the residue is removed from the shaded surfaces shown in the illustration.

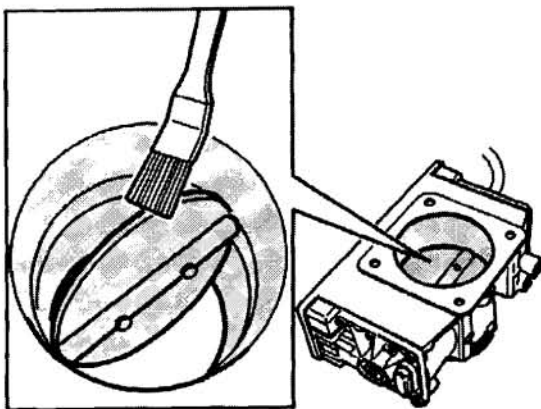

A2400089

12.

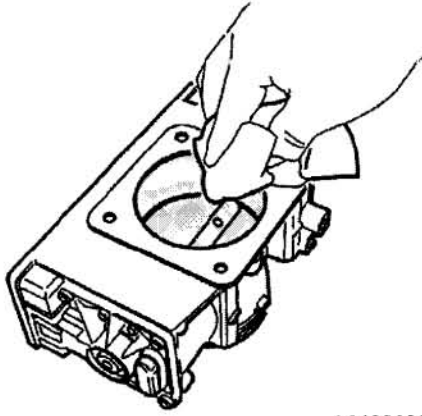

A2400090

Carefully wipe the bore clean on both sides of the throttle plate. Wipe clean the edge of the throttle disc.
Do not use compressed air to dry the throttle module.

13.

Installing the electronic throttle module (ETM)

Install:

- the electronic throttle module (ETM) with a new gasket
- the 4 x screws flush against mating surface.

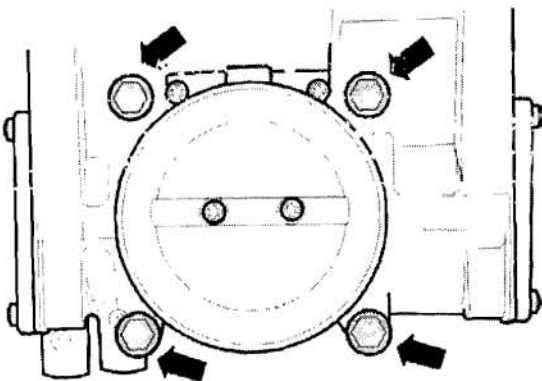

i-230120

14.

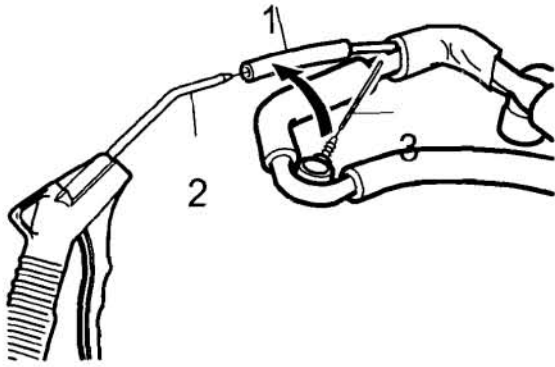

Cleaning crankcase ventilation

Remove the banjo bolt from the intake manifold.

Remove the hose (1) from the nipple.

Remove the oil filler cap.

Blow the hose clean (1) using compressed air (2).

Clean the hose using 2.0 mm diameter wire.

Note! If the hose is blocked, use a welding rod (maximum Ø 2.0mm, approximately 250 mm long) to unblock the hose.

Clean the nipple using a 2.0 mm diameter drill bit (3).

Install:

- the hose on the nipple
- the banjo bolt with new gaskets
- the oil filler cap.

Raise the car.

Remove the cover under the engine.

Tighten:

- the banjo bolt. Tighten to 24 Nm
- the four screws for the electronic throttle module (ETM). Tighten to 10 Nm.

Install the cover under the engine.

Lower the car.

i-229919

15.

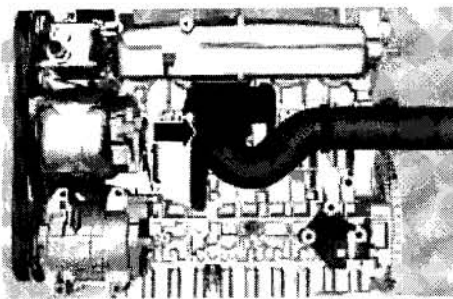

Install the charge air hose to the electronic throttle module (ETM). Tighten the clamp.

i-230280

16.

Installing the alternator

Install:

- the alternator in the correct position
- line upper screw but do not tighten
- both the screws common to the alternator and the air condition (A/C) compressor. Do not tighten.

Tighten:

- the upper screw. Tighten to 24 Nm
- the lower screws for the air conditioning (A/C) compressor. Tighten to 24 Nm
- the screws common to the alternator and the air conditioning (A/C) compressor. Tighten to 24 Nm.

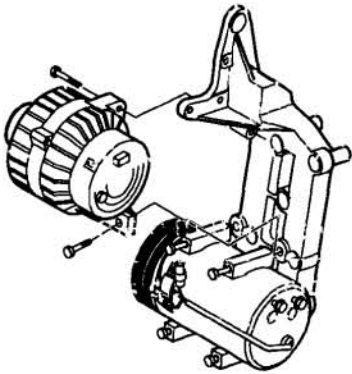

D3200073

17.

Installing the fan shroud

Carefully lower the fan shroud and align it with the holders. Pull the cable harness behind the holder (3).

Tighten both the mounting screws.

Depress the hose from the expansion tank in the holder on the fan shroud.

Secure the cable harness by the fan shroud using the tie straps (1) and (2). See illustration.

Install the canister purge (CP) valve.

Connect the engine cooling fan's connector.

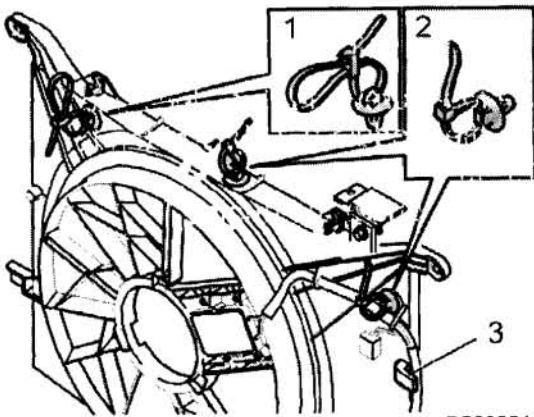

D2600311

18.

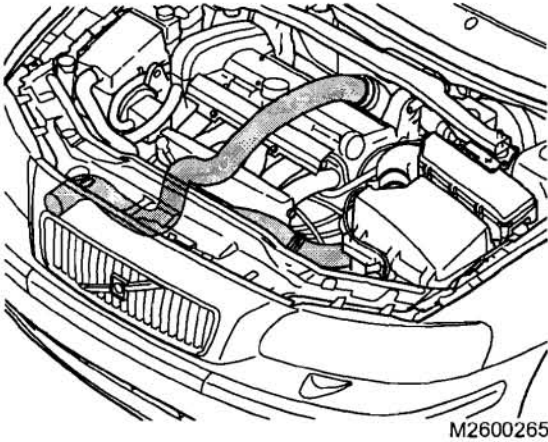

M2600265

Install:

- the charge air pipe to the turbo and the charge air cooler (CAC)
- the intake manifold to the air cleaner (ACL) housing.

19.

Installing the power steering pump

Install:

- the power steering pump in the correct position
- the 3 x screws through the pulley. Tighten to 24 Nm.

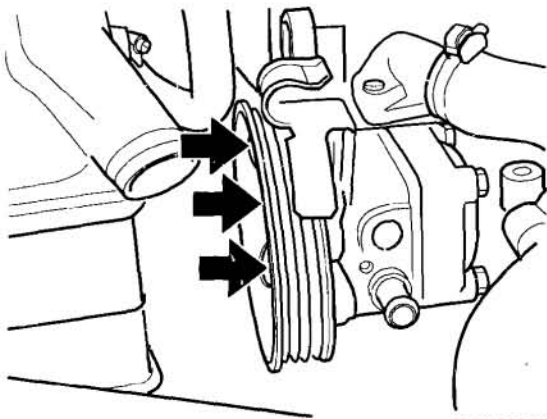

N6400614

20.

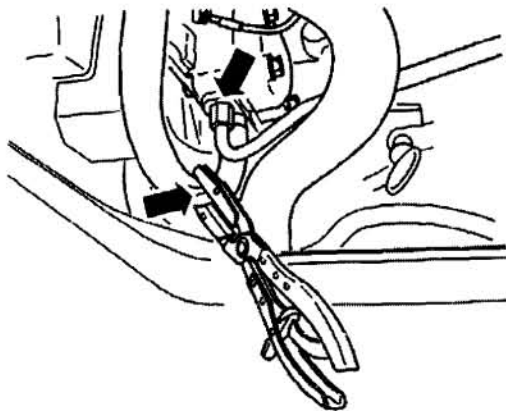

i-229918

Install the delivery line on the power steering pump. Use new O-rings on the delivery line. Tighten to 25 Nm. Remove the hose clip.

21.

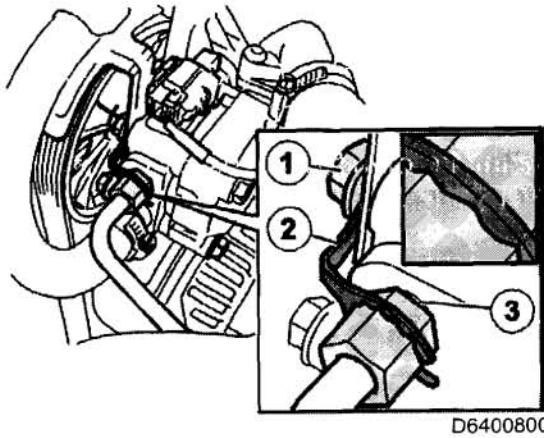

D6400800

If the vehicle has locking brackets

Install the locking bracket (2).

Tighten the screw (1). Tighten to 24 Nm.

Note! There may be a gap (3) of a few millimeters between the pipe coupling and the power steering pump. Bend the bracket so that the twelve edged mounting on the bracket is on the nut.

22.

Install:

- the auxiliaries belt. Use wrench: 999 7109
- the power steering reservoir in its mounting on the expansion tank
- the tie strap for the power steering hose by the suspension turret
- power steering hose in the holder on the belt protection on the power steering pump
- the connector with holder on the power steering pump.

23.

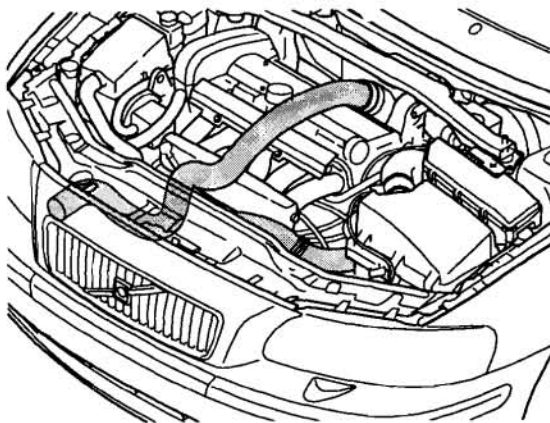

M2600265

Install:

- the charge air hose on the charge air cooler (CAC).
- the screw for the charge air pipe above the engine and clamp for the power steering pump delivery line from the intake manifold.
- the cold air inlet hose to the control module.

Check the level in the power steering reservoir and top up if necessary.

24.

Install:

Turn the ignition key to position 2.

Connect the battery cable to the negative battery terminal.

Start the engine and check for leaks.

25.

Repeated measurements of crankcase pressure

Connect the manometer according to TNN 25-149-B and confirm the repair.

Cleaning crankcase ventilation, 5-cyl Turbo (C70/S70/V70 (-00)/V70XC)

26.

Cleaning crankcase ventilation, 5-cyl Turbo (C70/S70/V70 (-00)/V70XC)**Remove:**

- the battery negative lead from the battery
- the auxiliaries belt. Use wrench 999 7109
- the cold air inlet hose to the control module
- oil dipstick pipe.

27.

Removing the power steering pump

Remove the power steering pump's three mounting screws through the pulley hole. Remove the connector with holder from the power steering pump.

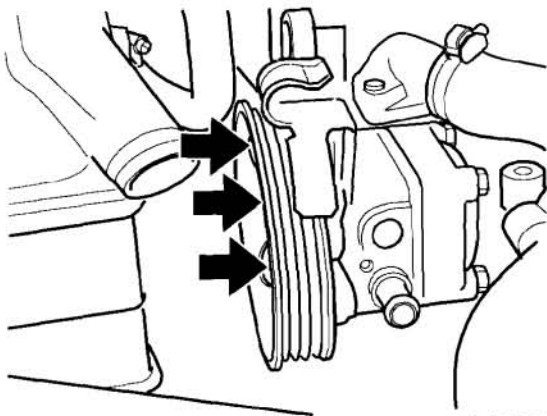

N6400614

28.

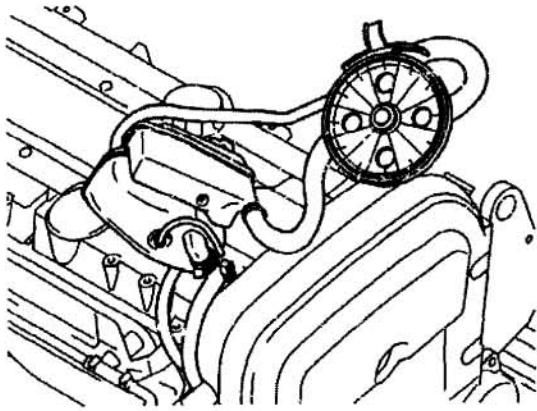

i-229917

Remove:

- power steering hoses and coolant hoses from their holders/clips). Remove the tie strap for the power steering hose by the suspension turret.
- the coolant expansion tank and the power steering reservoir from the mounting on the spring strut turret
- the connector and place the reservoirs on the engine.

Place the power steering pump up on the engine.

29.

Removing the alternator

Remove:

- the upper screw for the alternator
- the screws common to the alternator and compressor.

Loosen the lower screws for the compressor (so that there is some clearance).

Position the alternator so that it rests against the radiator and on the air conditioning (A/C) compressor.

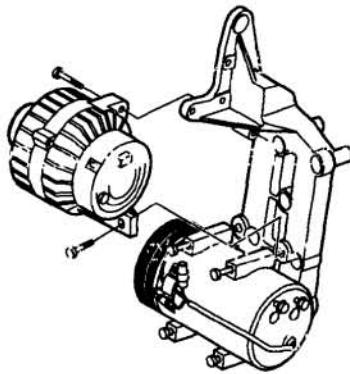

D3200073

30.

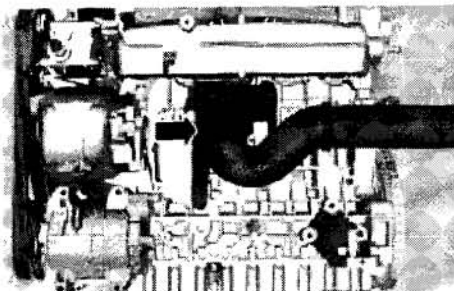

i-230280

Loosen the hose clamp for the charge air pipe on the electronic throttle module (ETM). Remove the charge air pipe from the electronic throttle module (ETM).

31.

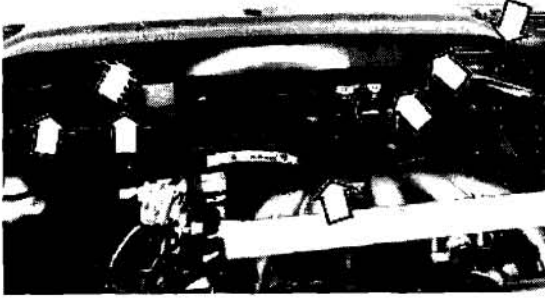

Remove:

- the air duct for the air cleaner (ACL) housing.
- the four screws holding the engine cooling fan's shroud.

Move the shroud to one side, pull up the relay holder and pull the connectors for the fan apart.

Remove:

- the charge air hose from the charge air cooler (CAC)
- hoses and wiring from their holders
- both engine cooling fan relay's from the fan shroud by bending the relays inwards towards the engine compartment and pulling upwards.

Open the tie strap for the wiring.

Remove:

- the connectors with holder on both sides of the fan shroud
- the canister purge (CP) valve from the fan shroud
- fan with shroud.

S152357

32.

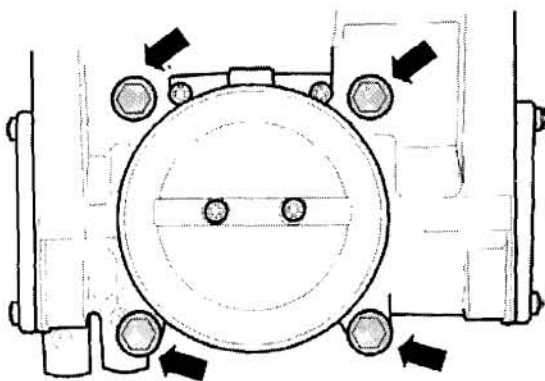

i-230120

Remove the 4 x screws for the electronic throttle module (ETM).

Cleaning the electronic throttle module (ETM)

Raise the electronic throttle module (ETM) and place it between the radiator and the intake manifold.

Place paper under the electronic throttle module (ETM).

Clean the throttle and bore as follows.

Note! Do not use compressed air when cleaning the electronic throttle module (ETM).

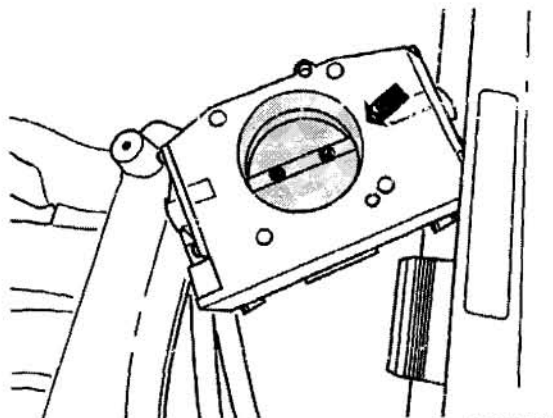

i-230121

2

Cleaning the ETM

Warning! DO NOT submerge throttle unit in cleaning solvent. ONLY use cleaning solvent recommended in this bulletin.

Important! Do not scrape or use a rotary wire brush to clean the unit.

Clean the ETM bore using cleaner (P/N 1161828) and a soft bristle brush.

Ensure that all the residue is removed from the shaded surfaces shown in the illustration.

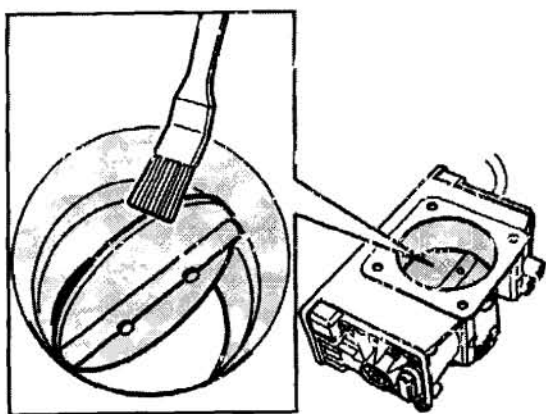

A2400089

34.

Carefully wipe the inside of the bore clean on both sides of the throttle disc. Wipe clean the edge of the throttle disc.

Do not use compressed air to dry the throttle module.

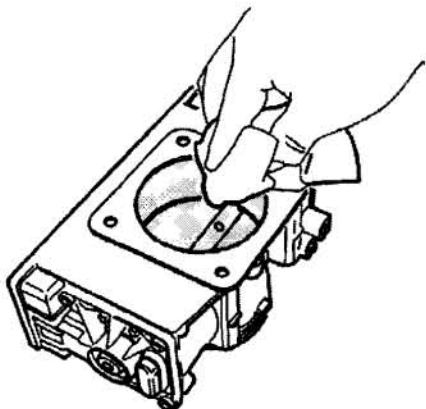

A2400090

Installing the electronic throttle module (ETM)**Install:**

- the electronic throttle module (ETM) with a new gasket
- the 4 x screws flush against mating surface.

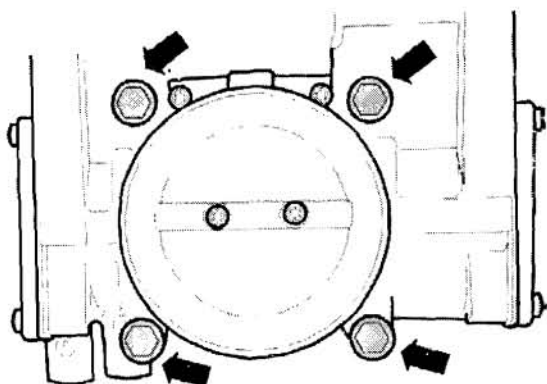

i-230120

Cleaning crankcase ventilation

Remove the banjo bolt from the intake manifold.

Remove the hose (1) from the banjo nipple.

Remove the oil filler cap.

Blow the hose clean (1) using compressed air (2).

Clean the hose using 2.0 mm diameter wire.

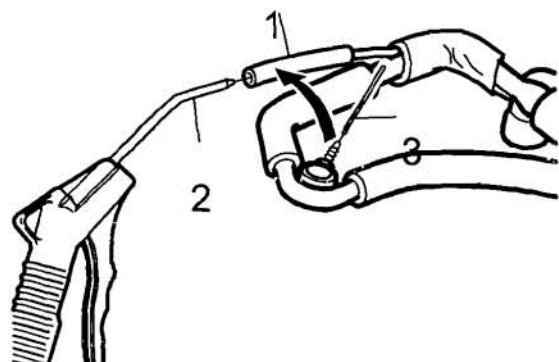

Note! If the hose is blocked, use a welding rod (maximum \varnothing 2.0mm, approximately 250 mm long) to unblock the hose.

Clean the banjo nipple using a 2.0 mm diameter drill bit (3).

Install:

- the hose on the nipple
- the banjo bolt with new gaskets
- the oil filler cap.

Raise the car.

Remove the cover under the engine.

Tighten:

- the banjo bolt. Tighten to 24 Nm
- the four screws for the electronic throttle module (ETM). Tighten to 10 Nm.

Install the cover under the engine.

Lower the car.

Installing the alternator

Install:

- the alternator in the correct position
- the upper screw but do not tighten
- both the screws common to the alternator and the air condition (A/C) compressor. Do not tighten.

Tighten:

- the upper screw. Tighten to 24 Nm
- the lower screws for the air conditioning (A/C) compressor. Tighten to 24 Nm
- the screws common to the alternator and the air conditioning (A/C) compressor. Tighten to 24 Nm.

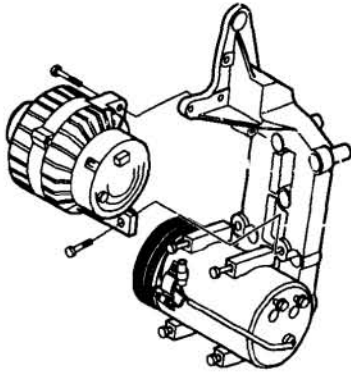

D3200073

37.

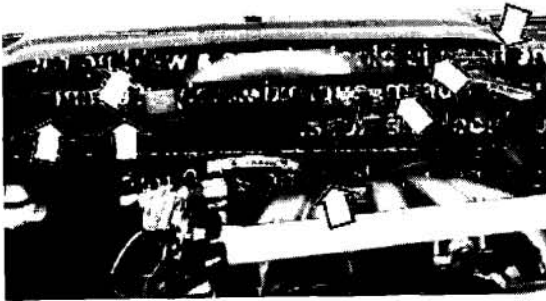

Install:

- fan shroud with its 4 x screws
- the holder for the connector before installing the lower screw on the fan shroud's (car's) left side. Tighten both the lower screws. Thread the 2 x uppermost screws
- the fan connectors
- the engine cooling fan's relay in the holder
- the canister purge (CP) valve to the fan shroud
- the connector with holder, fan shroud's right side
- the tie strap around the wiring
- hoses and wiring in their holders/clips
- the charge air hose to the charge air cooler (CAC)
- the relay holder. Tighten the upper screws.

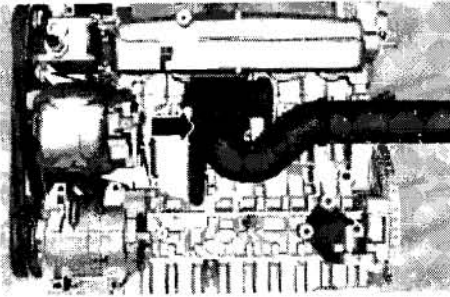

Installing the charge air pipe

Install the charge air pipe to the electronic throttle module (ETM)

Tighten the hose clamp for the charge air pipe on the electronic throttle module (ETM).

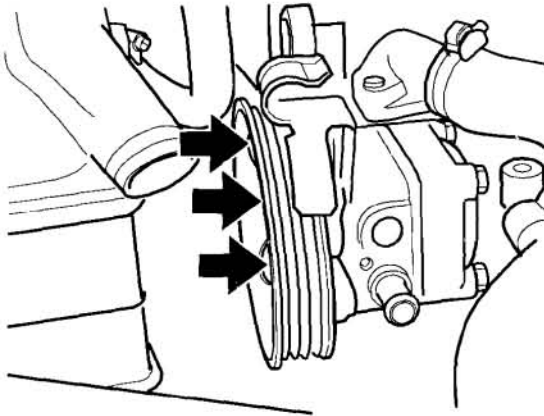

Installing the power steering pump

Install:

- the power steering pump
- the three screws. Tighten to 24 Nm
- the expansion tank and the power steering reservoir in the mounting on the spring strut turret
- the tie strap around the power steering hose by the suspension turret
- power steering hose and in the holder on the belt protection on the power steering pump
- the connector with holder on the power steering pump
- the coolant hose to the holder on the control module box
- the holder with coolant hose to the power steering hose

Install:

- the auxiliaries belt. Use wrench 999 7109
- the oil dipstick pipe
- the cold air inlet hose to the control module
- the air duct for the air cleaner (ACL) housing.

Turn the ignition key to position 2
Install the battery negative lead to the battery.

Repeated measurements of crankcase pressure

Connect the manometer according to TNN 25-149-B and confirm the repair.

Cleaning the crankcase ventilation and electronic throttle module (ETM), 6-cyl Turbo

38.

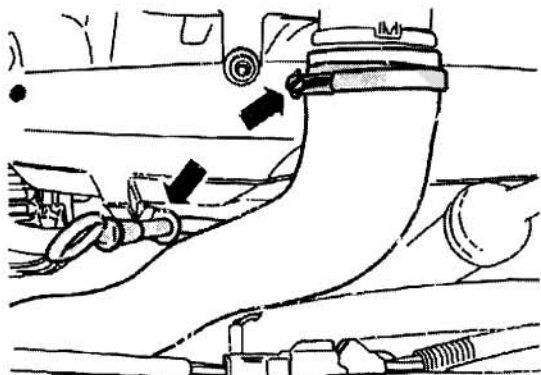

-227104

Remove:

- the battery negative lead, see: Electrical system Battery replacement
- the intake hose between the front and air cleaner (ACI.) housing
- the charge air hose from the charge air pipe
- the oil dipstick pipe.

The banjo nipple is located underneath the intake manifold, behind the mounting for the oil dipstick pipe.

39.

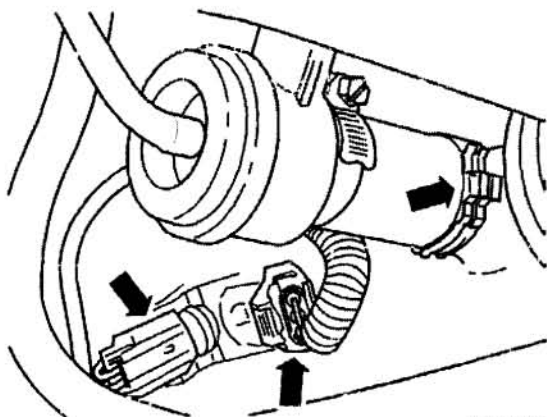

i-230383

Disconnect both the connectors from the charge air hose between the charge air cooler and electronic throttle module (ETM).

Remove:

- the hose clamps
- the by-pass valve from the charge air hose.

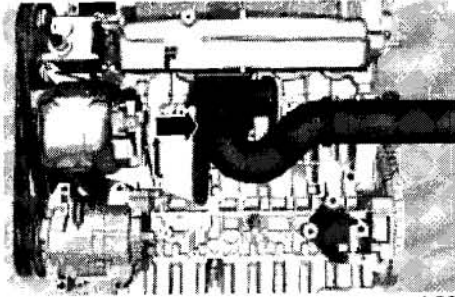

i-230280

Remove the hose clamp for the charge air pipe on the electronic throttle module (ETM) and the charge air cooler (CAC).
Remove the charge air pipe from the electronic throttle module (ETM) and the charge air cooler (CAC).

40.

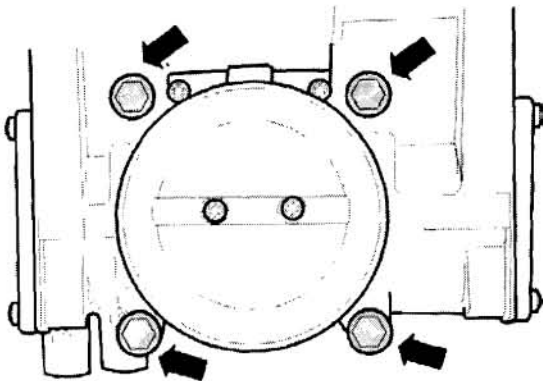

i-230120

Remove the 4 x screws for the electronic throttle module (ETM).

41.

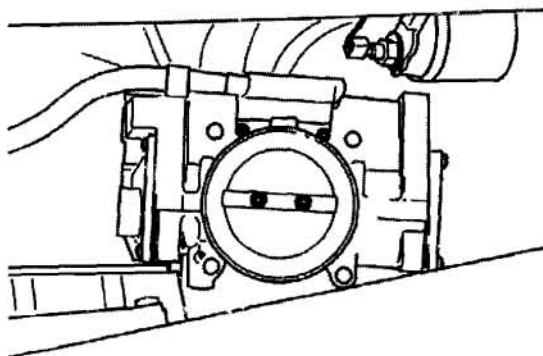

i-230382

Place paper between the fan shroud and the engine block.
Place the electronic throttle module (ETM) on the paper.

2

Cleaning the ETM

Warning! DO NOT submerge throttle unit in cleaning solvent. ONLY use cleaning solvent recommended in this bulletin.

Important! Do **not** scrape or use a rotary wire brush to clean the unit.

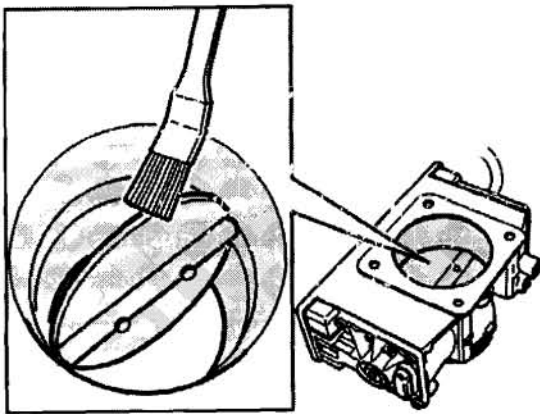

A2400089

Clean the ETM bore using cleaner (P/N 1161828) and a soft bristle brush.

Ensure that all the residue is removed from the shaded surfaces shown in the illustration.

42.

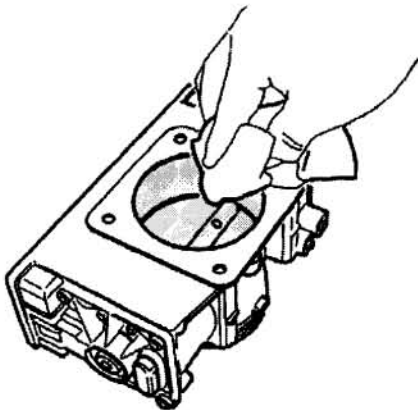

A2400090

Carefully wipe the inside of the bore clean on both sides of the throttle disc. Wipe clean the edge of the throttle disc.

Do not use compressed air to dry the throttle module.

43.

Cleaning crankcase ventilation

Remove the banjo bolt from the intake manifold.

Remove the hose (1) from the banjo nipple.

Remove the oil filler cap.

Blow the hose clean (1) using compressed air (2).

Clean the hose using 2.0 mm diameter wire.

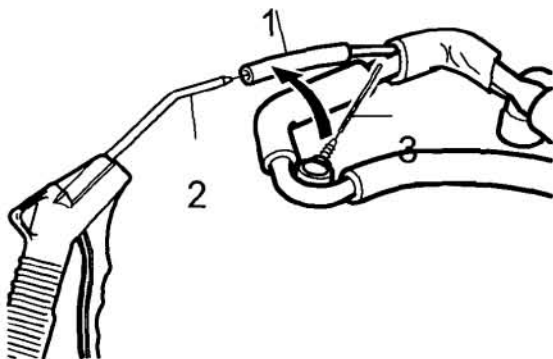

Note! If the hose is blocked, use a welding rod (maximum Ø 2.0mm, approximately 250 mm long) to unblock the hose.

Clean the banjo nipple using a 2.0 mm diameter drill bit (3).

Install:

- the hose on the banjo nipple
- the banjo bolt with new gaskets. Tighten to 24 Nm.
- the oil filler cap.

44.

Installing the electronic throttle module (ETM)

Install:

- the electronic throttle module (ETM) with a new gasket
- the 4 x screws for the electronic throttle module (ETM). Tighten to 10 Nm.

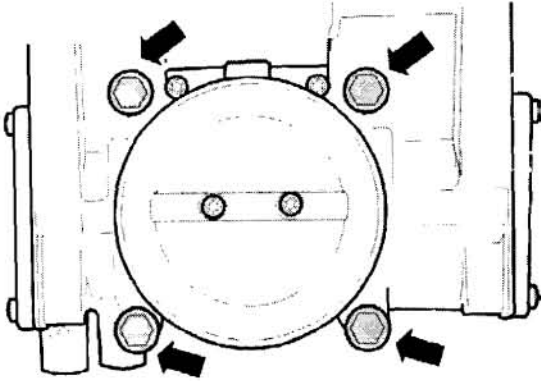

i-230120

45.

Installing the charge air pipe

Install the charge air pipe to the electronic throttle module (ETM) and the charge air cooler (CAC).

Tighten the hose clamps for the charge air pipe on the electronic throttle module (ETM).

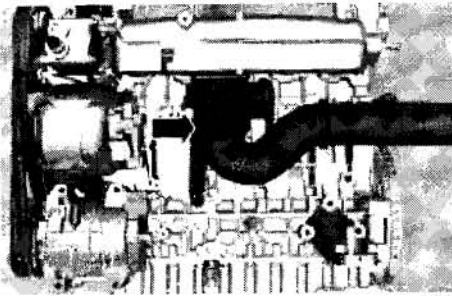

i-230280

46.

Install:

- both the connectors from the charge air hose between the charge air cooler and electronic throttle module (ETM).
- the by-pass valve to the charge air hose with clamp.

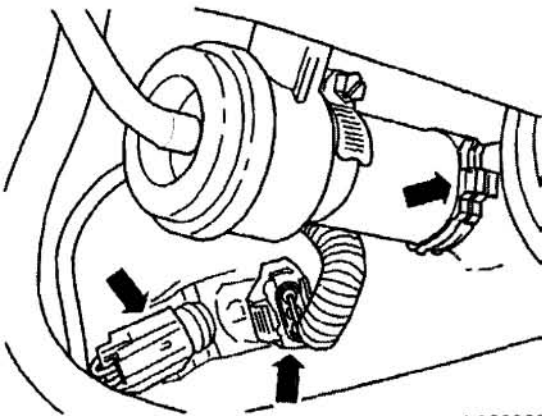

i-230383

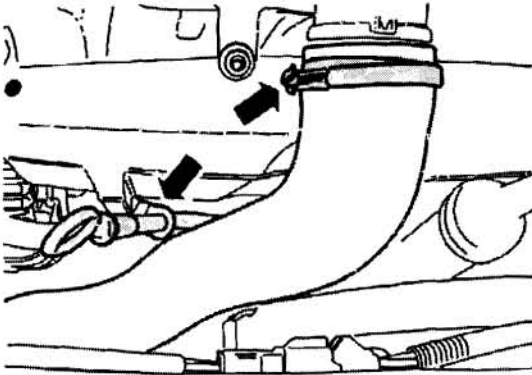

i-227101

Install:

- the oil dipstick pipe
- the charge air hose to the charge air pipe
- the intake hose between the front and air cleaner (ACL) housing.

48.

Finishing work

Turn the ignition key to position 2.
Connect the battery cable to the negative battery terminal.

49.

Repeated measurements of crankcase pressure

Connect the manometer according to TNN 25-149-B and confirm the repair.

**Cleaning the crankcase ventilation and electronic throttle module (ETM),
6-cyl Non turbo**

50.

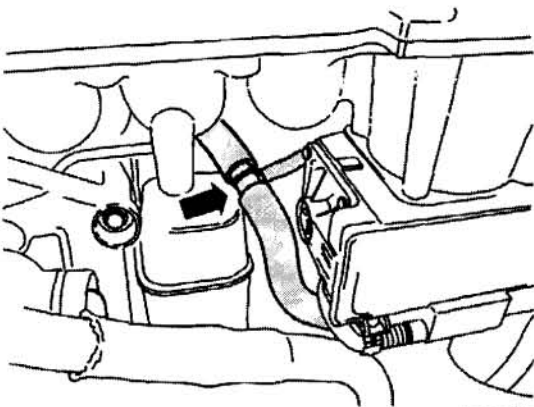

i-227102

Remove:

- the battery negative lead, see:
Electrical system
Battery replacement
- the oil dipstick pipe
- the two thick hoses from the T-nipple.

51.

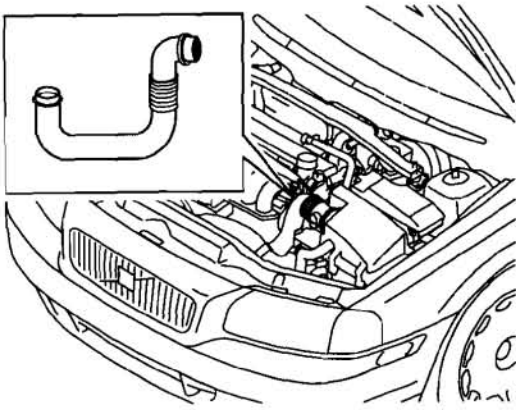

D2700494

Remove the intake manifold between the electronic throttle module (ETM) and the air cleaner.

52.

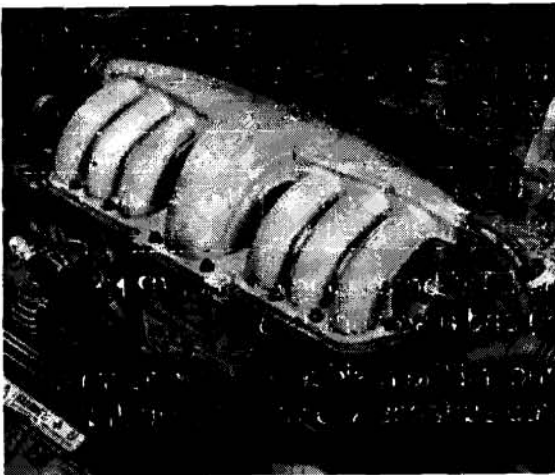

S2101328

Remove the ten screws at the intake manifold mating flange.
Lift off the upper section of the intake manifold.
Install the protection 999 5723.

53.

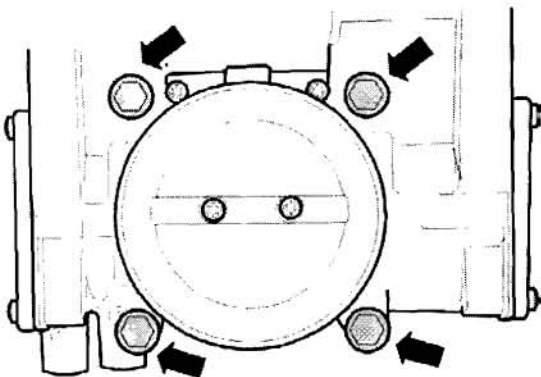

i-230120

Remove the 4 x screws for the electronic throttle module (ETM).

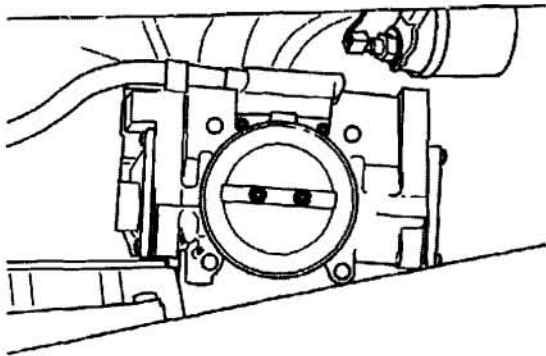

i-230382

Place paper between the fan shroud and the engine block.
Place the electronic throttle module (ETM) on the paper.

Cleaning the ETM

Warning! DO NOT submerge throttle unit in cleaning solvent. ONLY use cleaning solvent recommended in this bulletin.

Important! Do not scrape or use a rotary wire brush to clean the unit.

Clean the ETM bore using cleaner (P/N 1161823) and a soft bristle brush.

Ensure that all the residue is removed from the shaded surfaces shown in the illustration.

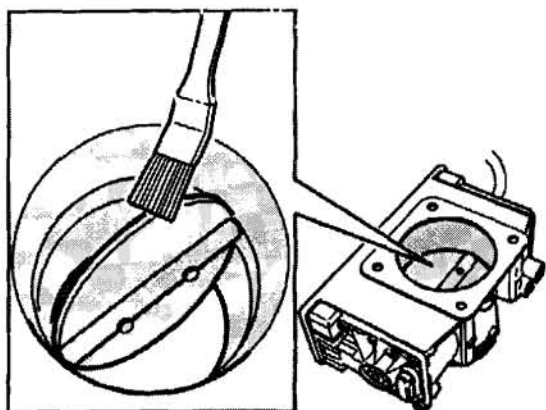

A2400089

Carefully wipe the inside of the bore clean on both sides of the throttle disc. Wipe clean the edge of the throttle disc.
Do not use compressed air to dry the throttle module.

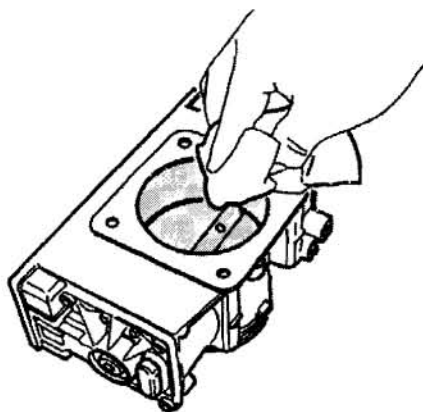

A2400090

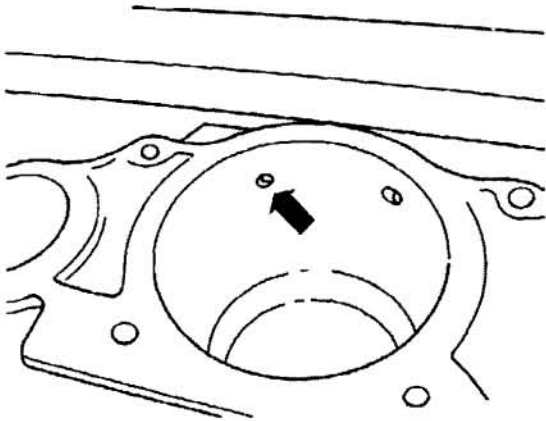

Remove the hose with the T-nipple from the intake manifold.

Remove the protection 999 5723.

Clean the hole in the intake manifold using a 2 mm drill bit.

Remove the hose from the T-nipple.

Clean the T-nipple. Use a 2 mm drill bit.

Clean the hose using 2 mm wire and blow clean using compressed air.

Wipe clean the intake manifold's air duct.

Install the hose on the T-nipple.

Install the hose with the T-nipple to the intake manifold.

Install the protection 999 5723.

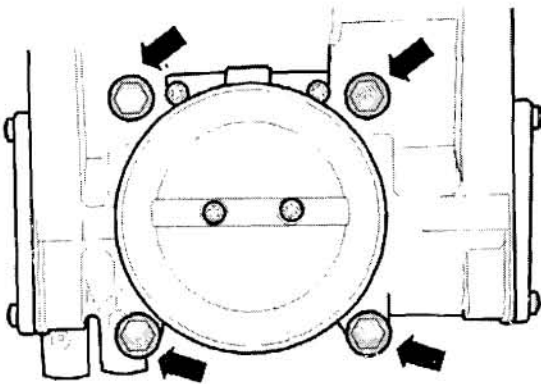

i-230120

Install:

- the electronic throttle module (ETM) with a new gasket
- the 4 x screws for the electronic throttle module (ETM). Tighten to 10 Nm.

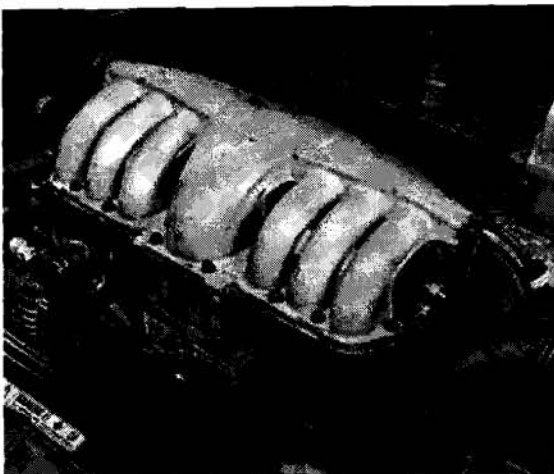

S2101328

Remove the protection 999 5723.

Install new gasket

Install the upper section of the intake manifold. Tighten the screws from the inside out alternately. Tighten to 17 Nm.

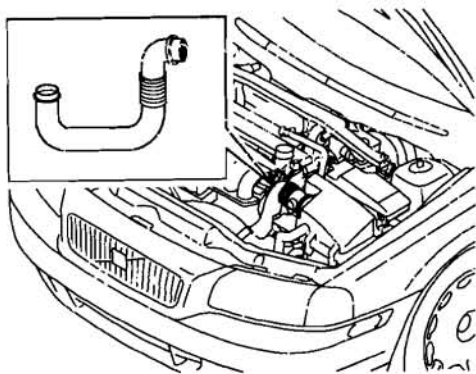

D2700494

Install the intake manifold between the electronic throttle module (ETM) and the air cleaner.

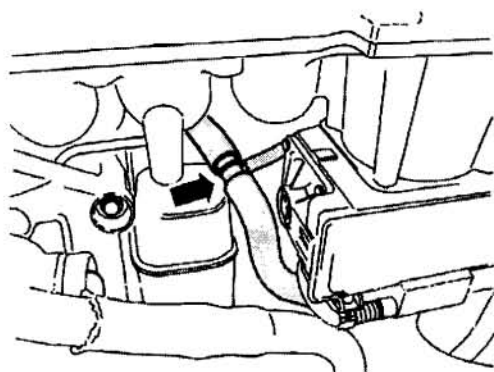

i-227102

Install:

- the two thick hoses to the T-nipple

Note! The T-nipple's thickest coupling to the flame trap.

- the oil dipstick pipe.

Finishing work

Turn the ignition key to position 2.
Connect the battery cable to the negative battery terminal.

Repeated measurements of crankcase pressure

Connect the manometer according to TNN 25-149-B and confirm the repair.

VOLVO for life,
Volvo Cars of North America, LLC
Technical Service

Please circulate, read and initial: _____ Svc Mgr _____ Parts Mgr _____ Shop Foreman

_____ TECHS

_____ Warranty Administrator _____ S Advisors

Tech-Net Notes

"Fixed Right – First Time"

Volvo Technicians, Service and Parts Managers

NO: 25-149-E
DATE: 01-02-2007
MODEL/YEAR: C70 1999-2002
S70 1999-2000
S60 2001-2002
V70 1999-2002
V70XC 1999-2001
S80 1999-2001
SUBJECT: Recall 155 - Electronic Throttle Module (ETM) Replacement
REFERENCE: SMB 25-155, VIDA, TNN 25-149-A, TNN 25-149-B

This Tech Net Note supersedes the previous TNN 25-149E dated 03-03-2006. Please update your files.

DESCRIPTION:

This TNN describes an update of the existing method for Electronic Throttle Module (ETM) replacement. Replacement must always be preceded by fault-tracing according to VIDA and TNN 25-149-A.

S60 2001 V70 2001 V70XC 2001 5-cyl Turbo

Material

Description	Quantity	Part Number
Throttle Module	1	8644347
Gasket	1	8636753
Cable tie	2	983662
Cable tie	3	983614
Cable tie*	2	983750
ETM reload, S60 2001	1	8645425
ETM reload, V70 2001 V70XC 2001	1	9494714
ECM gasoline upgrade	1	30677021

* Used if needed

Throttle Module replacement 5-cyl Turbo S60 2001 V70 2001 V70XC 2001

1.

Detach the battery cable from the negative battery terminal. See:
Electrical system
Battery replacement

2.

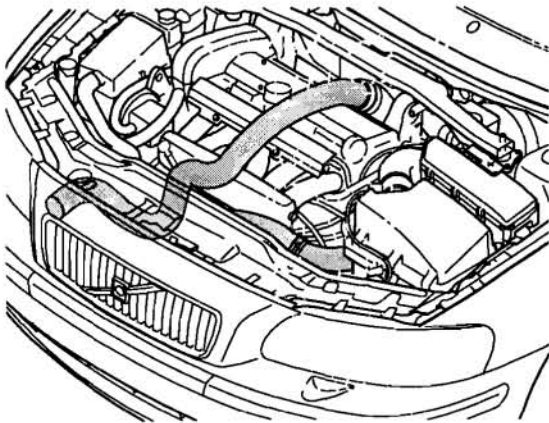

M2600265

Remove the charge air pipe bolts from the intake manifold across the engine.

Remove:

- dipstick guide tube
- charge air hose from intercooler.
- charge air pipe from rubber connection on turbocharger.

Remove the charge air pipe and charge air hose.

3.

Removing the fan cowling

Remove the intake manifold to the air filter housing.

Detach both connectors of the electric cooling fan.

Remove:

- EVAP valve to electric cooling fan from fan cowling
- the four cable ties holding the cable harness in place at the fan cowling.

Note! Some cars have three cable ties and a clip to hold the cable harness in place at the fan cowling.

Lift the expansion tank hoses out of the holes at the top edge of the fan cowling.

Remove both bolts holding the fan cowling in place.

Carefully raise the electric cooling fan.

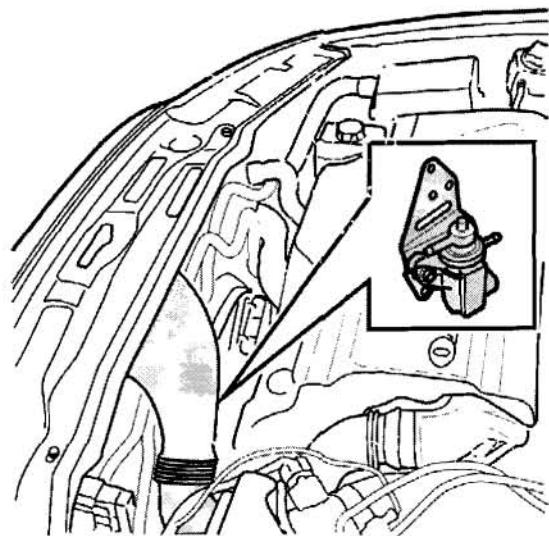

D2600258

4.

Removing the electronic throttle module (ETM)

Loosen the hose clamp of the charge air pipe on the electronic throttle module (ETM).
Remove the charge air pipe from the electronic throttle module (ETM).

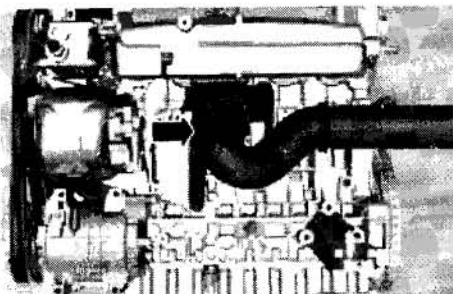

i-230280

5.

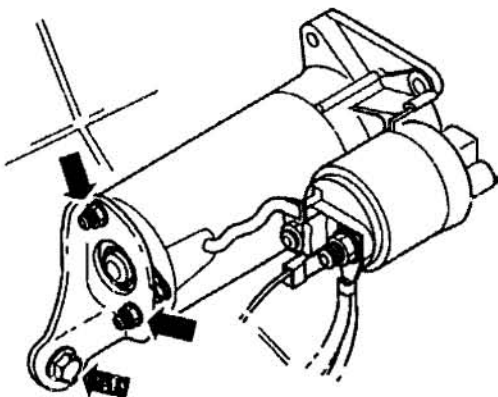

i-231945

Caution! Do not cut the electrical cable to the electronic throttle module (ETM). It may be necessary to return the electronic throttle module (ETM) assembly.

If the electric cable of the electronic throttle module (ETM) is behind the starter motor bracket:
Slacken the two nuts.
Remove the bolt.
Remove any cable ties and unplug the electronic throttle module (ETM) connector.
Pull the electrical cable of the electronic throttle module (ETM) forward from the back of the starter motor bracket.

6.

Remove the 4 x screws for the electronic throttle module (ETM).

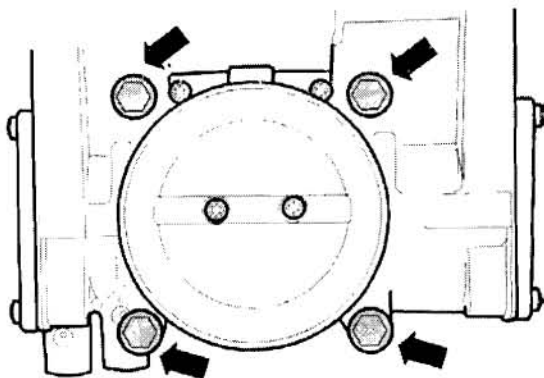

i-230120

7.

Installing the electronic throttle module (ETM)

Install:

- the new electronic throttle module (ETM) with new gasket
- the 4 screws until they make contact.

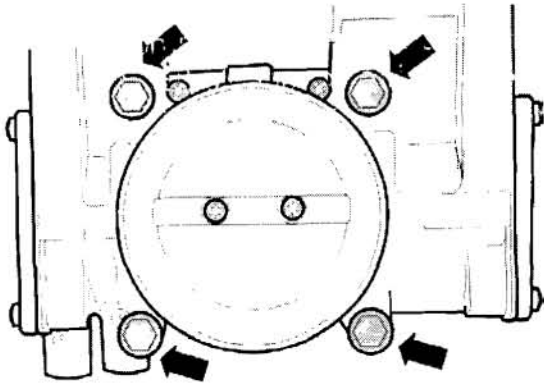

I-230120

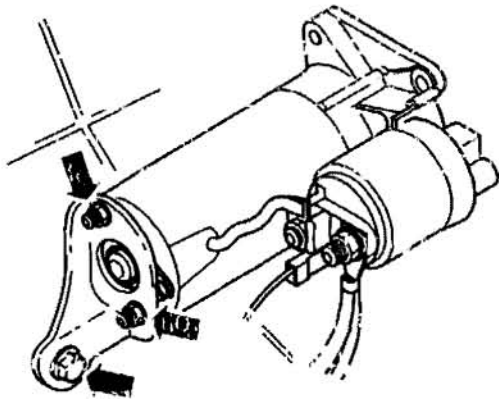

Route the electrical cable for the electronic throttle module (ETM) behind the starter motor bracket.

Fit the bolt in the engine block.

Tighten the two nuts and the bolt.

Plug in the connector and install the cable tie.

Note! If the cable was not routed behind the starter motor bracket, fasten the cable along the cable duct using two strip clamps.

8.

Raise the car.

Remove the cover from below the engine.

Tighten the 4 electronic throttle module (ETM) screws. Tightening torque 10 Nm.

Install the cover below the engine.

Lower the car.

9.

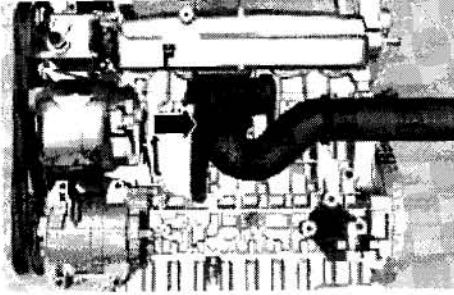

i-230280

Attach the charge air hose to the electronic throttle module (ETM) and tighten the clamp.

10.

Installing the fan cowling

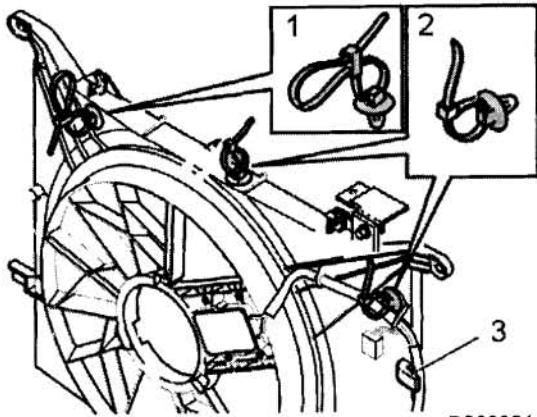

D2600311

Carefully lower the fan cowling and align it with the retainers. Route the cable harness behind the retainer (3).

Tighten the two retaining bolts.

Press down the hose from the expansion tank into the retainer on the fan cowling.

Use cable ties (1) and (2) to secure the cable harness at the fan cowling. See illustration.

Fit the EVAP-valve.

Plug in the electric cooling fan connectors.

11.

Install:

- the charge air hose/charge air pipe between the intercooler and the rubber connection on the turbocharger
- the two charge air pipe bolts on the intake manifold
- the intake manifold to the air filter housing
- the intake manifold between the front and air filter housing.

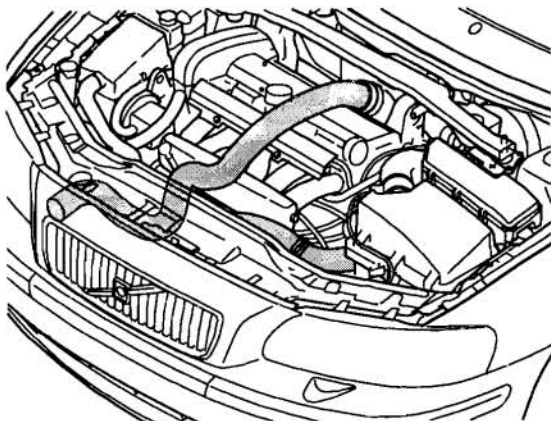

M2600265cgm

12.

Install:

- dipstick guide tube

Turn the ignition key to position 2.
Connect the battery cable to the negative
battery terminal.

13.

Ordering and downloading software

Note! After ETM reload the ECM must be upgraded.

Order and download software for ETM reload
and ECM gasoline upgrade.

14.

Finishing work

Check that no diagnostic trouble codes were
stored in the control module during repair
work.

Test drive the car and check the functionality
of the engine.

Electronic Throttle Module (ETM) replacement 5-cyl Turbo C70 1999-2002 S70/V70 1999-2000 V70XC 1999-2000

15.

Detach the battery cable from the negative
battery terminal.
Remove the dipstick guide tube.

16.

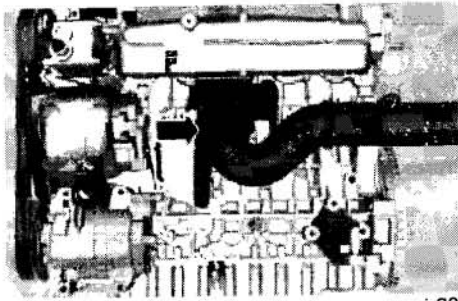

i-230280

Removing the electronic throttle module (ETM)

Loosen the hose clamp of the charge air pipe on the electronic throttle module (ETM). Remove the charge air pipe from the electronic throttle module (ETM).

17.

Remove:

- the intake manifold between the front and air filter housing.
- the four bolts holding the fan cowling cover in place.

Move the cover aside slightly, pull up on the relay holder and unplug the fan connectors.

Remove:

- the charge air hose from the intercooler
- hoses and electrical cables from their retainers
- the two electric cooling fan relays from the fan cowling by bending the relays in toward the engine compartment and pulling up.

Open the cable ties of the electrical cables.

Remove:

- the connectors with retainers on both sides of the fan cowling
- the EVAP valve from the fan cowling
- the fan with cowling

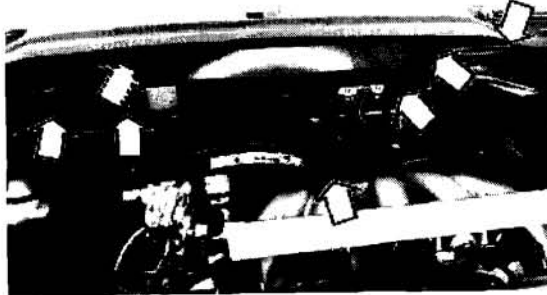

S152357

18.

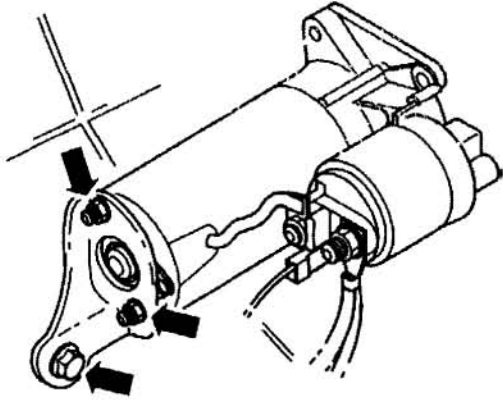

i-231945

Caution! Do not cut the electrical cable to the electronic throttle module (ETM). It may be necessary to return the electronic throttle module (ETM) assembly.

If the electric cable of the electronic throttle module (ETM) is behind the starter motor bracket:

Slacken the two nuts.

Remove the bolt.

Remove any cable ties and unplug the electronic throttle module (ETM) connector.

Pull the electrical cable for the electronic throttle module (ETM) forward from in back of the starter motor bracket.

19.

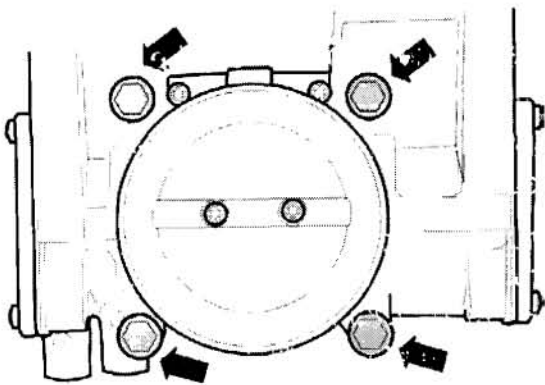

i-230120

Remove the 4 electronic throttle module (ETM) screws.

20.

Installing the electronic throttle module (ETM)

Install:

- the new electronic throttle module (ETM) with new gasket
- the 4 bolts until they make contact.

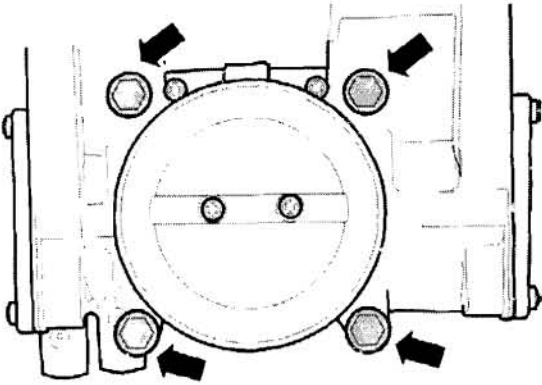

i-230120

21.

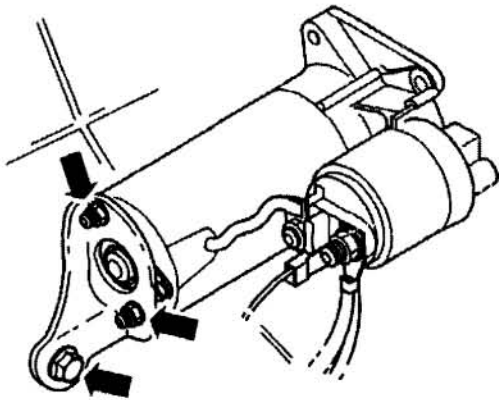

i-231945

Route the electrical cable from the electronic throttle module (ETM) behind the starter motor bracket.

Fit the bolt in the engine block.

Tighten the two nuts and the bolt.

Plug in the connector and install the cable tie.

Note! If the cable was not routed behind the starter motor bracket, fasten the cable along the cable duct using two strip clamps.

22.

Raise the car.

Remove the cover from below the engine.

Tighten the 4 electronic throttle module (ETM) bolts. Tightening torque 10 Nm.

Install the cover below the engine.

Lower the car.

23.

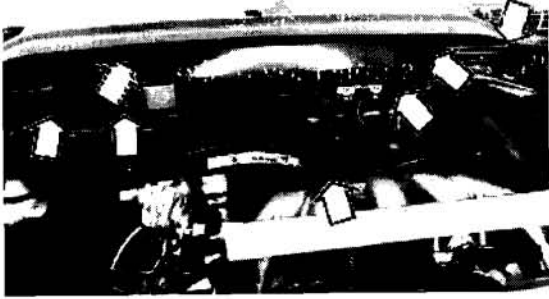

S152357

Install:

- the fan cowling with its 4 bolts
- the connector retainer before the lower bolt on the fan cowling's (car's) left side is inserted. Tighten the lower bolts. Insert the 2 upper bolts.
- the fan connectors
- the electric cooling fan relay in the holder
- the EVAP valve to the fan cowling
- the connector with retainer on the right side of the fan cowling
- cable ties around electrical cables
- hoses and electrical cables in their retainers/clips
- the charge air hose to the intercooler
- the relay holder and tighten the upper bolts.

24.

Installing the charge air pipe

Install the charge air pipe to the electronic throttle module (ETM).
Tighten the hose clamp of the charge air pipe on the electronic throttle module (ETM).

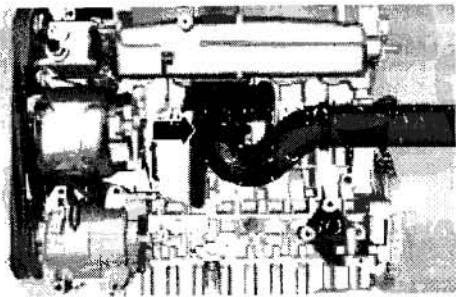

i-230280

Install:

- dipstick guide tube
- the intake manifold between the front and air filter housing.

Turn the ignition key to position 2.

Connect the battery cable to the negative battery terminal.

Ordering and downloading software

Note! After ETM reload the ECM must be upgraded.

Order and download software for ETM reload and ECM gasoline upgrade.

Finishing work

Check that no diagnostic trouble codes were stored in the control module during repair work.

Test drive the car and check the functionality of the engine.

**Electronic Throttle Module (ETM) replacement 5-cyl Non-turbo S70 1999-2000 S60
2001-2002 V70 1999-2002**

Note! The method applies to only replacing the throttle module for the S70 1999-2000 S60 2001-2002 V70 1999-2002 5-cyl Non-turbo

Remove:

- the battery negative lead from the battery. When removing and installing the battery leads. See: Electrical system
Battery replacement

29.

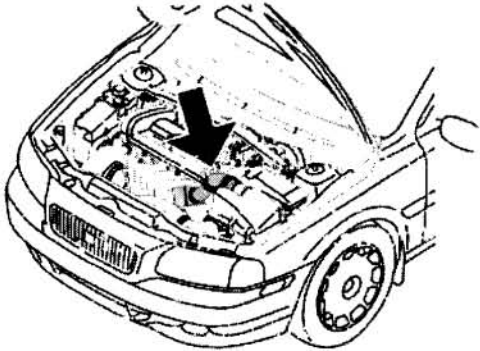

M2600265

Remove:

- the intake pipe between the front cover plate and the air cleaner.
- the intake pipe between the air cleaner.

30.

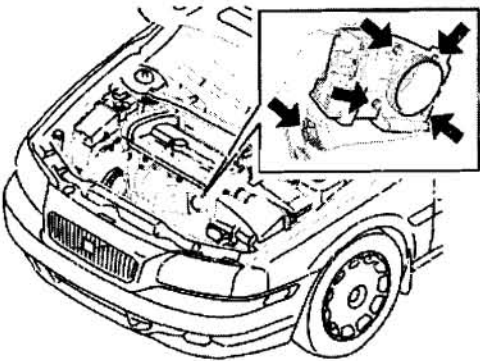

M2600265

Remove:

- the 4 electronic throttle module (ETM) screws.

Disconnect the electronic throttle module (ETM) connector

31.

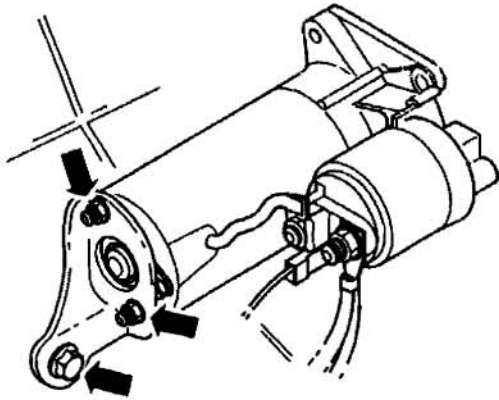

i-231945

Caution! Do not cut the electrical cable to the electronic throttle module (ETM). It may be necessary to return the electronic throttle module (ETM) assembly.

If the electric cable of the electronic throttle module (ETM) is behind the starter motor bracket:

Slacken the two nuts.

Remove the bolt.

Remove any cable ties.

Pull the electrical cable for the electronic throttle module (ETM) forward from in back of the starter motor bracket.

32.

Installing the electronic throttle module (ETM)

Install:

- the new electronic throttle module (ETM) with new gasket
- the 4 bolts and tighten to 10 Nm..

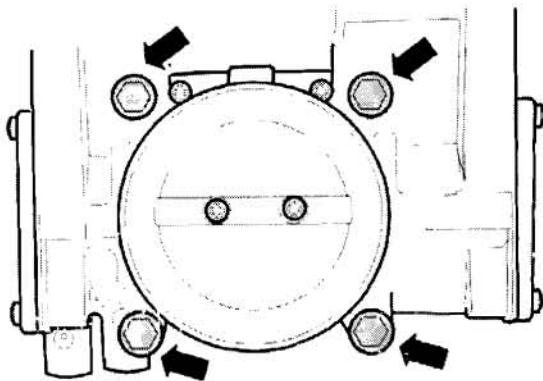

i-230120

33.

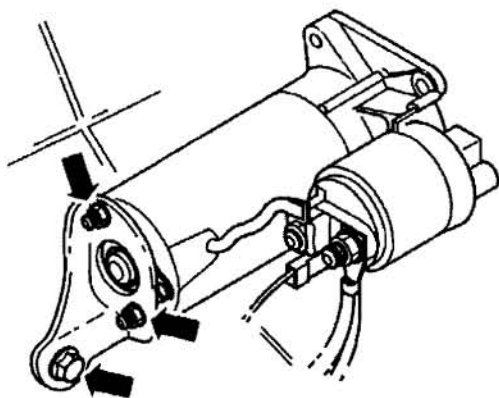

i-231945

Route the electrical cable from the electronic throttle module (ETM) behind the starter motor bracket.

Fit the bolt in the engine block.

Tighten the two nuts and the bolt.

Plug in the connector and install the cable tie.

Note! If the cable was not routed behind the starter motor bracket, fasten the cable along the cable duct using two strip clamps.

34.

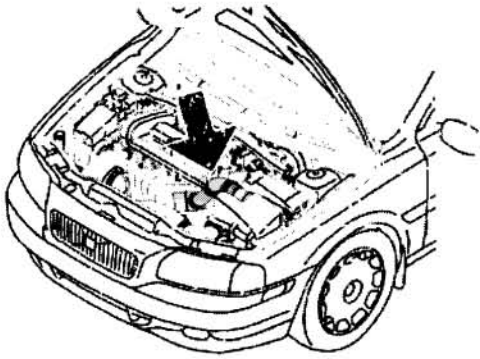

M2600265

Install:

- the intake pipe between the air cleaner and the electronic throttle module (ETM).
- the intake pipe between the air cleaner and the front cover plate.

35.

Turn the ignition key to position 2.
Connect the battery cable to the negative battery terminal.

36.

Ordering and downloading software

Note! After ETM reload the ECM must be upgraded.

Order and download software for ETM reload and ECM gasoline upgrade.

37.

Finishing work

Check that no diagnostic trouble codes were stored in the control module during repair work.

Test drive the car and check the functionality of the engine.

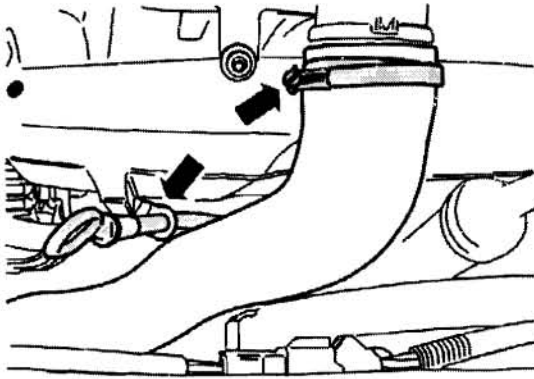

i-227101

Remove:

- the battery cable to the negative battery terminal. See: Electrical system Battery replacement.
- the intake manifold between the front and air filter housing
- the charge air hose from the charge air pipe and move it aside
- dipstick guide tube.

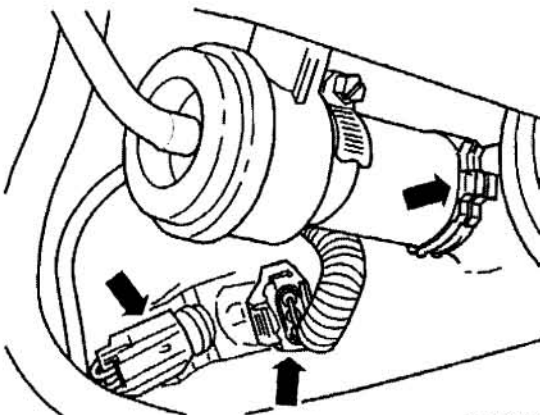

i-230383

Unplug the two connectors from the charge air hose between the intercooler and electronic throttle module (ETM). Open the hose clamp. Remove the overflow valve from the charge air hose.

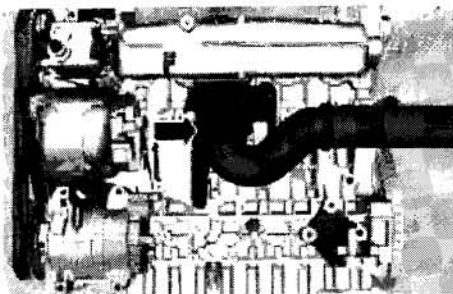

i-230280

Loosen the hose clamp of the charge air pipe on the electronic throttle module (ETM) and intercooler. Remove the charge air pipe from the electronic throttle module (ETM) and intercooler.

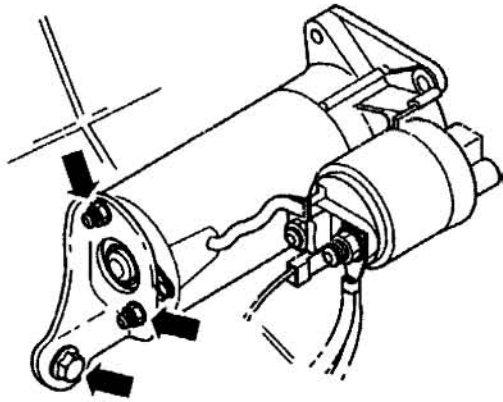

i-231945

Caution! Do not cut the electrical cable to the electronic throttle module (ETM). It may be necessary to return the electronic throttle module (ETM) assembly.

If the electric cable from the electronic throttle module (ETM) is behind the starter motor bracket:

Slacken the two nuts.

Remove the bolt.

Remove any cable ties and unplug the electronic throttle module (ETM) connector. Pull the electrical cable from the electronic throttle module (ETM) forward from in back of the starter motor bracket.

42.

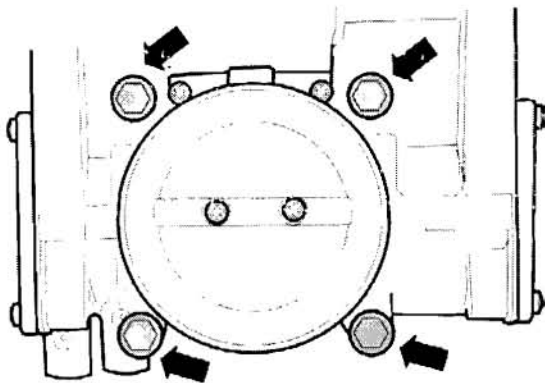

i-230120

Remove the 4 electronic throttle module (ETM) bolts.

43.

Installing the electronic throttle module (ETM)

Install:

- the new electronic throttle module (ETM) with new gasket
- the 4 bolts until they make contact.

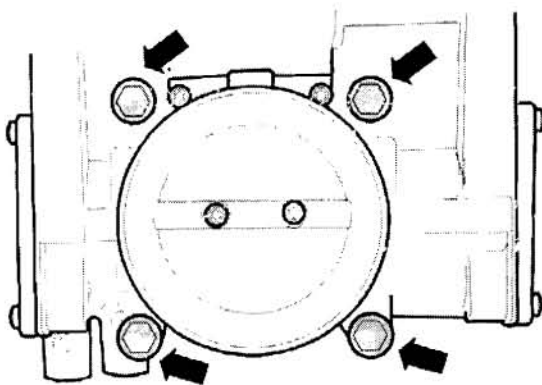

i-230120

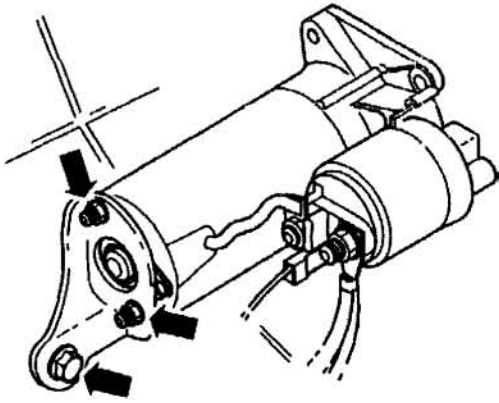

i-231945

Route the electrical cable from the electronic throttle module (ETM) behind the starter motor bracket.

Fit the bolt in the engine block.

Tighten the two nuts and the bolt.

Plug in the connector and install the cable tie.

Note! If the cable was not routed behind the starter motor bracket, fasten the cable along the cable duct using two strip clamps.

Raise the car.

Remove the cover from below the engine.

Tighten the 4 electronic throttle module (ETM) bolts. Tightening torque 10 Nm.

Install the cover below the engine.

Lower the car.

Installing the charge air pipe

Install the charge air pipe to the electronic throttle module (ETM) and intercooler.

Tighten the hose clamp of the charge air pipe on the electronic throttle module (ETM).

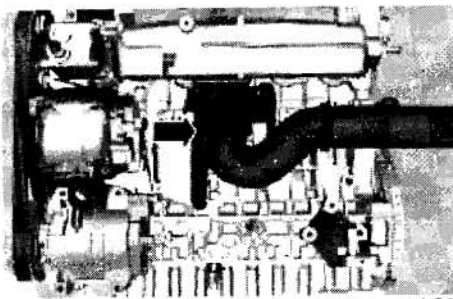

i-230280

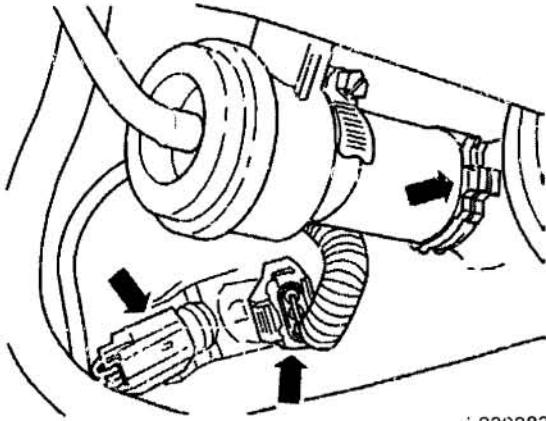

i-230383

Plug in the two connectors of the charge air hose between the intercooler and electronic throttle module (ETM).
Fit the overflow valve to the charge air hose with the clamp.

48.

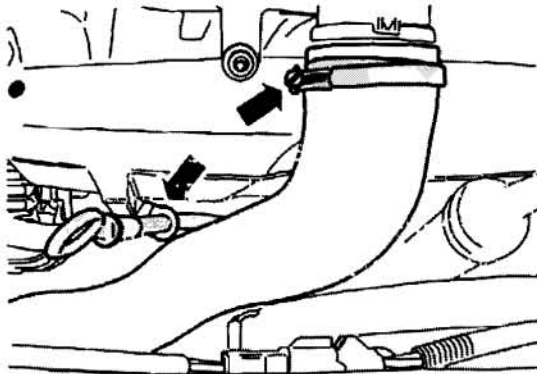

i-227101

Install:

- dipstick guide tube
- the charge air hose to the charge air pipe
- the intake manifold between the front and air filter housing

Turn the ignition key to position 2.
Connect the battery cable to the negative battery terminal.

49.

Ordering and downloading software

Note! After ETM reload the ECM must be upgraded.

Order and download software for ETM reload and ECM gasoline upgrade.

50.

Finishing work

Check that no diagnostic trouble codes were

stored in the control module during repair work.

Test drive the car and check the functionality of the engine.

Electronic Throttle Module (ETM) replacement 6-cyl Non turbo

51.

Remove:

- the battery cable from the negative battery terminal. See: Electrical system Battery replacement.
- dipstick guide tube.

52.

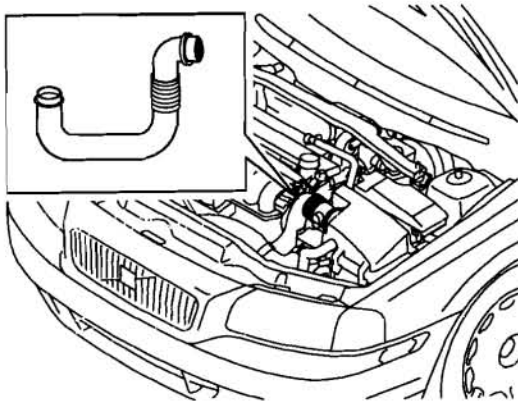

D2700494

Remove the intake manifold between the electric throttle module (ETM) and air filter.

53.

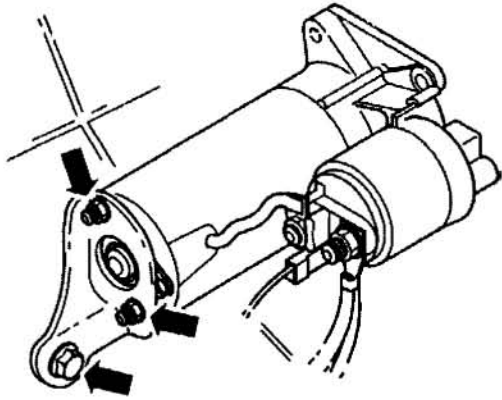

i-231945

Caution! Do not cut the electrical cable to the electronic throttle module (ETM). It may be necessary to return the electronic throttle module (ETM) assembly.

If the electric cable from the electronic throttle module (ETM) is behind the starter motor bracket:

Slacken the two nuts.

Remove the bolt.

Remove any cable ties and unplug the electronic throttle module (ETM) connector.

Pull the electrical cable for the electronic throttle module (ETM) forward from in back of the starter motor bracket.

54.

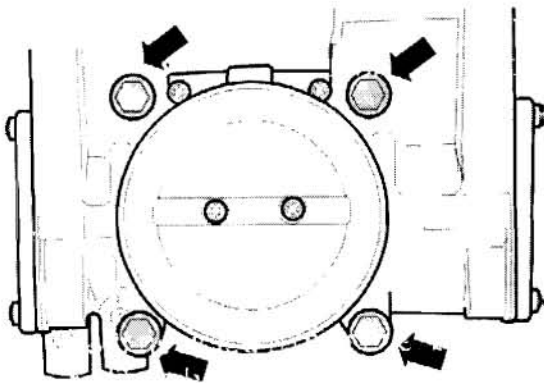

i-230120

Remove the 4 electronic throttle module (ETM) bolts.

55.

Installing the electronic throttle module (ETM)

Install:

- the new electronic throttle module (ETM) with new gasket
- the 4 bolts until they make contact.

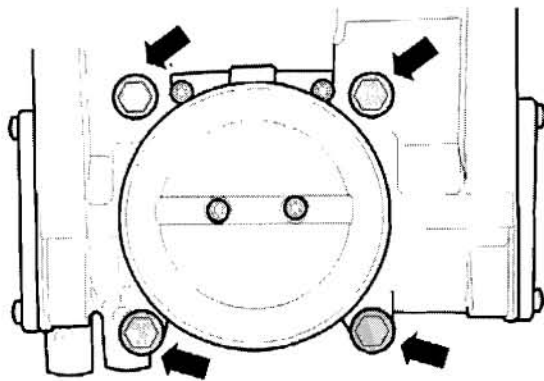

i-230120

56.

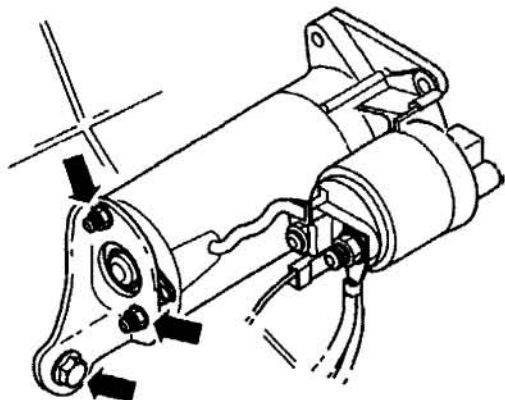

i-231945

Route the electrical cable for the electronic throttle module (ETM) behind the starter motor bracket.
Fit the bolt in the engine block.
Tighten the two nuts and the bolt.
Plug in the connector and install the cable tie.

Note! If the cable was not routed behind the starter motor bracket, fasten the cable along the cable duct using two strip clamps.

57.

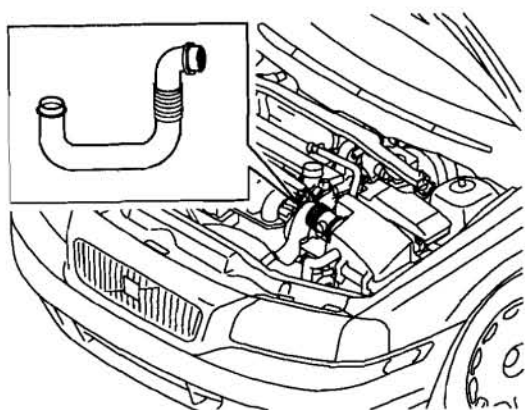

D2700494

Install:

- intake manifold between the electronic throttle module (ETM) and air filter
- dipstick guide tube.

58.

Finishing work

Turn the ignition key to position 2.
Connect the battery cable to the negative battery terminal.

59.

Ordering and downloading software

Note! After ETM reload the ECM must be upgraded.

Order and download software for ETM reload and ECM gasoline upgrade.

60.

Finishing work

Check that no diagnostic trouble codes were stored in the control module during repair work.

Test drive the car and check the functionality of the engine.

VOLVO for life,
Volvo Cars of North America, LLC
Technical Service

Please circulate, read and initial: _____ Svc Mgr _____ Parts Mgr

_____ TECHS

_____ Shop Foreman _____ Warranty Administrator

Tech-Net Notes

"Fixed Right – First Time"

Volvo Technicians, Service and Parts Managers

NO:	25-149F
DATE:	01-02-2007
MODEL/YEAR:	C70 1999-2002 S70 1999-2000 S60 (2001 all engine variants), (2002 non-turbo only). V70 (1999-2001 all engine variants), (2002 non-turbo only). V70XC, 1999-2000 XC70 2001 S80 1999-2001
SUBJECT:	Electronic Throttle System Software - Upgrade
REFERENCE:	TNN 25-149A

This Tech Net Note supersedes the previous TNN 25-149F dated 03-16-2006. Please update your files.

DESCRIPTION:

Beginning March 17th 2006 there will be an Electronic Throttle System (ETS) software upgrade available for the vehicles listed above. The software contains changes that will reduce driver disturbances by allowing the system to better differentiate between glitches or minor disturbances, and system faults. The upgraded software will also reduce driver disturbances due to idle oscillations caused by dirt build-up in the throttle. TNN 25-149A will be updated to guide service technicians on the changes. The fault tracing for each DTC in the TNN will give guidance on where it is appropriate to use the software as a solution for DTC's triggered in the vehicles current software. As the ETS software resides in both the Electronic Throttle Module (ETM) and the Engine Control Module (ECM), both will receive new software with the upgrade.

When to download the Electronic throttle system upgrade:

- The Electronic throttle system software upgrade should be installed into a customer's vehicle at the first service opportunity. Where the customer requests or consents to the upgrade.
1. If there are no ETS faults in the vehicle, and the customer requests or consents to their ETS being upgraded with the latest software, proceed to download the software as described in the "Service" section below.

2. Should the vehicle be brought in with an existent ETS fault:
 Fault trace according to TNN 25-149A, to best determine if the fault will be resolved by upgrading the software. A repair or service may be needed before upgrading the software.

Please check the TNN date to ensure the latest version is always being used

Important Note:

Current VIDA fault tracing for ETS should not be followed unless indicated as part of a diagnosis for a DTC in TNN 25-149A.

If either ETM or ECM should need to be replaced, as part of fault tracing, both the ETM and the ECM will receive the upgraded software, when the new Module is downloaded. And the upgrade would not need to be made subsequently.

SERVICE:

Upgrade the ETS using the appropriate software part number in the table below, for the vehicle being serviced.

Vehicle type and model year	Software Product number
S80 1999-2001 S60, V70 & XC70 2001 turbo engines, S60, V70 2001-2002 non-turbo engines.	30785453
C70 1999-2002	30785452
S70, V70, V70 XC 1999-2000	30785451

If necessary the upgraded ETS software can be confirmed in a vehicle, by reading the following software part numbers from the ECM and ETM using VIDA.

Software part numbers with Electronic throttle system upgrade							
5 & 6 Cylinder Turbocharged engines Plus 6 Cylinder non turbo						5 cylinder non turbo	
ECM	ETM	ECM	ETM	ECM	ETM	ECM	ETM
30785203AC	30785180A	30785216AB	30785180A	30785229AB	30785180A	30785118AA	30785179A
30785204AC	30785180A	30785217AB	30785180A	30785230AB	30785180A	30785119AA	30785179A
30785205AC	30785180A	30785218AB	30785180A	30785231AB	30785180A	30785120AA	30785179A
30785206AC	30785180A	30785219AB	30785180A	30785232AB	30785180A	30785121AA	30785179A
30785207AC	30785180A	30785220AB	30785180A	30785233AB	30785180A	30785122AA	30785179A
30785208AC	30785180A	30785221AB	30785180A	30785234AB	30785180A	30785123AA	30785179A
30785209AC	30785180A	30785222AB	30785180A	30785235AC	30785180A	30785124AA	30785178A
30785210AC	30785180A	30785223AB	30785180A	30785236AC	30785180A	30785125AA	30785178A
30785211AC	30785180A	30785224AB	30785180A	30785237AC	30785180A	30785126AA	30785178A
30785212AB	30785180A	30785225AB	30785180A	30785238AB	30785180A	30785127AA	30785178A
30785213AB	30785180A	30785226AB	30785180A	30785239AB	30785180A	30785128AA	30785178A
30785214AB	30785180A	30785227AB	30785180A	30785240AB	30785180A		
30785215AB	30785180A	30785228AB	30785180A				

To summarize:

If you have a 5 cylinder non turbo where the ECM software is in the series

30785(118xx-128xx) and ETM software part # is 3078517(8A-9A), the latest ETS software is in the vehicle.

For any other engine if the ECM software is in the series 30785(203xx-240xx) and the ETM software is 30785180A, the latest ETS software is in the vehicle.

SW part #'s other than in the table above indicate that the upgrade has not been applied to the vehicle.

WARRANTY CLAIM INFORMATION		
LABOR OP	LABOR DESCRIPTION	LABOR TIME
36004-2	SOFTWARE DOWNLOAD	0.3hr

VOLVO for life,
Volvo Cars of North America, LLC
Technical Service

Please circulate, read and initial: _____ Svc Mgr _____ Parts Mgr

_____ TECHS

_____ Shop Foreman _____ Warranty Administrator

IMPORTANT RECALL NOTICE

[RECALL 155: ELECTRONIC THROTTLE SYSTEM SOFTWARE UPGRADE
SAMPLE OWNER NOTIFICATION LETTER
UNITED STATES]

December 2006

Dear Volvo Owner:

This notice is sent to you in accordance with the requirements of the National Traffic and Motor Vehicle Safety Act.

The reason for this Recall Campaign:

Volvo Cars of North America, LLC. (Volvo) has decided that a defect which relates to motor vehicle safety exists in certain model year 1999-2002 Volvo vehicles. The Volvo vehicles that may be involved in this recall action are identified below:

- MY1999 to MY2001 Volvo models (not including the Volvo S40 and V40 models)
- MY2002 Volvo S60 and V70 with naturally aspirated engines
- MY2002 Volvo C70

In certain of the involved vehicles, a combination of throttle positioning sensor irregularities, a dirty throttle housing, and/or inefficient software calibration may cause the onset of limp home modes without warning. In certain traffic situations, this condition could cause an unsafe situation and possibly a crash.

The corrective action is to have the current software upgrade installed onto the involved vehicles.

What you need to do:

Please call your authorized Volvo retailer as soon as possible to schedule an appointment. This procedure will be completed at no cost and will take approximately 1/2 hour. Due to service scheduling, your Volvo retailer may require your vehicle for a longer period of time.

If you previously paid to have this specific ETM software upgrade corrective action performed, your authorized Volvo retailer will honor your receipt for this software upgrade with a refund. Please contact the Service Department for details.

Refer to the enclosed "Important Warranty Notice", which you may already have received, for detailed information about an electronic throttle module system extended warranty for which your vehicle may be eligible.

Please contact:

If you have any questions, please contact your Volvo retailer. If your retailer is unable to answer your questions, please contact Volvo Customer Care Center at 7 Volvo Drive, Rockleigh, NJ 07647 or phone 1-800-458-1552, Monday through Friday, 8:30 A.M. to 7:00 P.M. Eastern Time. You may also e-mail us at customercare@volvoforlife.com.

We have advised the National Highway Traffic Safety Administration (NHTSA) that we are conducting this recall. If you are unable to have this procedure performed without charge and within a reasonable period of time, you may contact the NHTSA Administrator (National Highway Traffic Safety Administration), 400 Seventh Street, SW., Washington, DC 20590 or call the toll-free Vehicle Safety Hotline at 1-888-327-4236 (TTY: 1-800-424-9153) or go to <http://www.safercar.gov>.

Federal law requires that any vehicle lessor receiving this recall notice must forward a copy of this notice to the lessee within ten days. Lessor means a person or entity that is the owner, as reflected on the vehicle title, of any five or more leased vehicles.

Your safety and continued satisfaction with your Volvo and the Volvo organization are very important to us. We apologize for any inconvenience this may cause and we appreciate your cooperation in arranging to have this important service completed as quickly as possible.

Sincerely,

Eunice Stern
Manager, Customer Care

Please note: According to Insurance Institute for Highway Safety President Adrian Lund, "It is very important that owners of vehicles in which safety-related problems have been identified take those vehicles back to dealerships as soon as they receive notice of a recall or service campaign. Such notices should not be ignored or taken lightly. There is just no reason to drive around in a vehicle with a safety-related defect."