

IMPORTANT: This brochure has been compiled by Mercedes-Benz Australia/Pacific Pty Ltd to provide a general indication of the range of models, optional extras and/or colours available in Australia. Some of the models, optional extras and/or colours shown may not be available in Australia or may only be available in a different specification. Additionally, some models, optional extras and/or colours may only be available in combination with others. For current information on the availability, design features and prices of all models, optional extras and/or colours available in Australia, you should contact your authorised smart dealer. All of the information contained in this brochure was correct at the time of printing, May 2011. However, the manufacturer reserves the right to make changes to design and specification without notice.



and Mercedes-Benz are registered trademarks of Daimler AG, Stuttgart, Germany.

Mercedes-Benz Australia/Pacific Pty Ltd.
ABN 23 004 411 410.
44 Lexia Place, Mulgrave, Victoria 3170.

Phone: (03) 9566 9266.



open your mind.

>> The new generation smart fortwo





01 Introduction.

smart city solutions

02 Comfort.

Simple parking

Innovative space concept

Generous luggage compartment

Clever everyday solutions

Change gear by tapping

03 Environment.

A little goes a long way

04 Safety.

smart safety concept

Passive safety

Active safety

05 Models.

The smart fortwo pulse

smart fortwo coupé or cabrio

Standard features

Special equipment features

Mix and match colours

06 Options.

Exterior equipment

Interior equipment

Functional & electrical
equipment

Audio & sound equipment

Luggage & stowage

Equipment packages

07 Service & accessories.

Your authorised smart centre

Leasing and financing

smart services

smart accessories

Rear rack systems

Luggage compartment
accessories

The smart collection

08 Overview

The engines

Technical data

www.smartaustralia.com.au

01 Introduction.

>> smart city solutions.

The smart fortwo has the essence of urban mobility in its genes. After all, it was designed specially for the needs of modern cities.

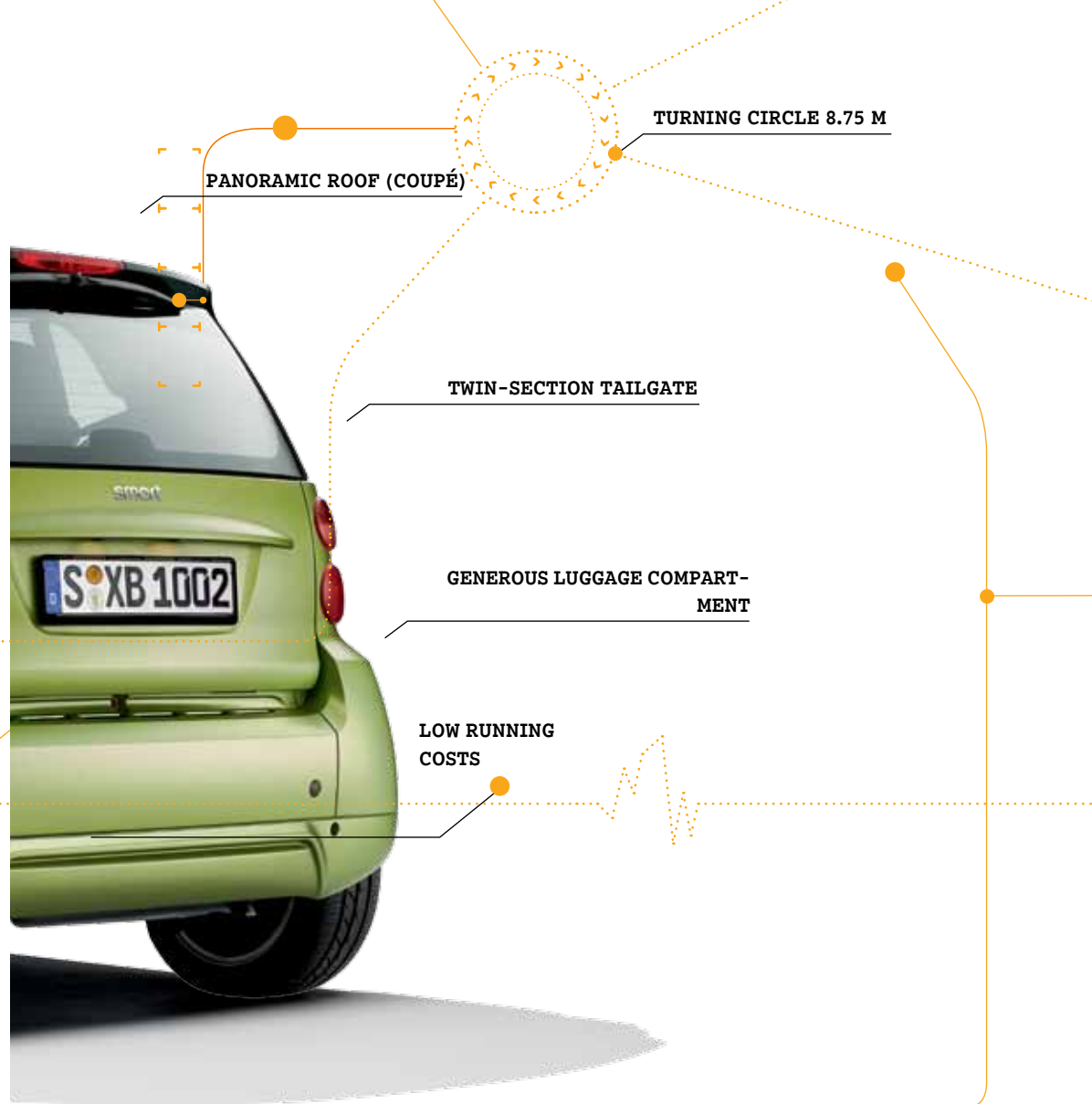

TRIDION SAFETY CELL

TRITOP SOFT TOP (CABRIO)

CHANGE GEAR BY TAPPING

SPACE CONCEPT

SMART INTELLIGENT DRIVE

BODYPANELS

HILL START ASSIST



02 Comfort.

Comfort often means having things in easy reach. In fact, it is a word that could well be used to describe city life, where everything is close at hand and where there is a wealth of possibilities around every corner.

But even if the distances travelled are short, you are often faced with stop-and-go traffic and a scarcity of parking spaces. Although a smart fortwo can't prevent traffic jams, the vehicle concept offers you maximum comfort and convenience.

>> Simple parking.

There's almost always room for 2.69 metres.

Whether you are rushing to an important meeting or need to run a quick errand, there is no need to waste any time looking for a parking space. At just 2.69 metres in length, the smart fortwo fits easily into spaces that drivers of other cars reject on sight.

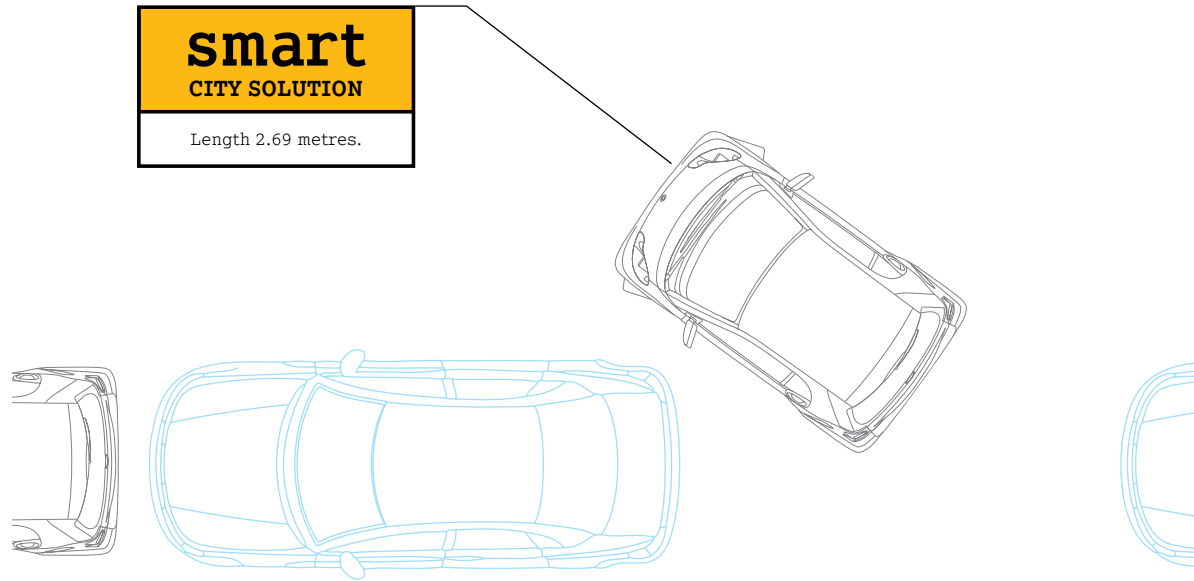



>> Innovative space concept.

If you've ever been in a smart fortwo, you'll know that the feeling of comfort begins as soon as you get in through the large doors. And once you've sat down, you're surprised by the spacious interior and the excellent all-round visibility.

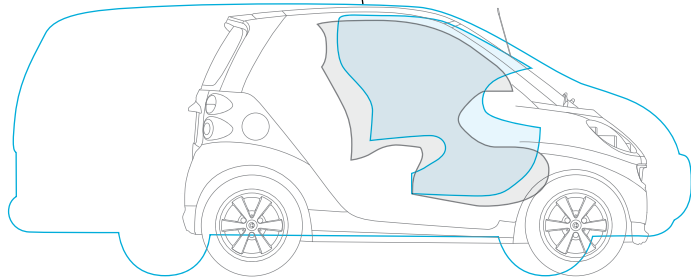

Spaciously smart.

Whether its the large cab-forward windscreen or the upright seating position, the smart fortwo interior offers the same feeling of spaciousness as a van. Meaning that even taller smart enthusiasts will enjoy the same level of comfort.

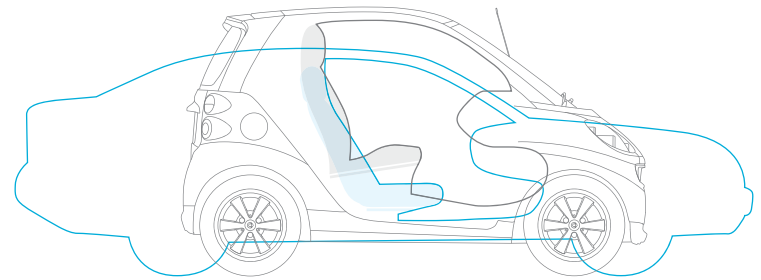

Keeping "on top of things".

One of the many advantages of the smart fortwo design is that the raised seating position giving you excellent all-round vision, even in the heaviest traffic.

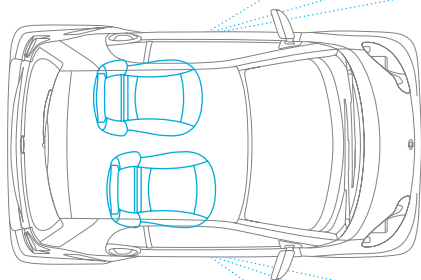

Discover visible advantages.

Particularly in city traffic, it is vital to be able to see everything that is going on around you. The large windows of the smart fortwo ensure exceptional all-round visibility. This is not only safer, but also more practical.



Intelligent seating arrangements.

The passenger seat is positioned further back providing additional arm and legroom and better side visibility for the driver.



smart
CITY SOLUTION

Generous luggage compartment.

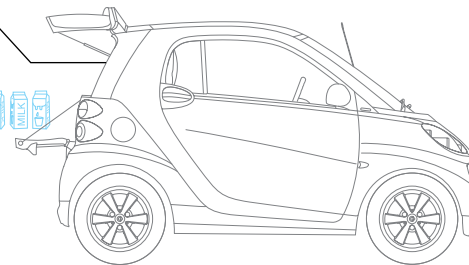
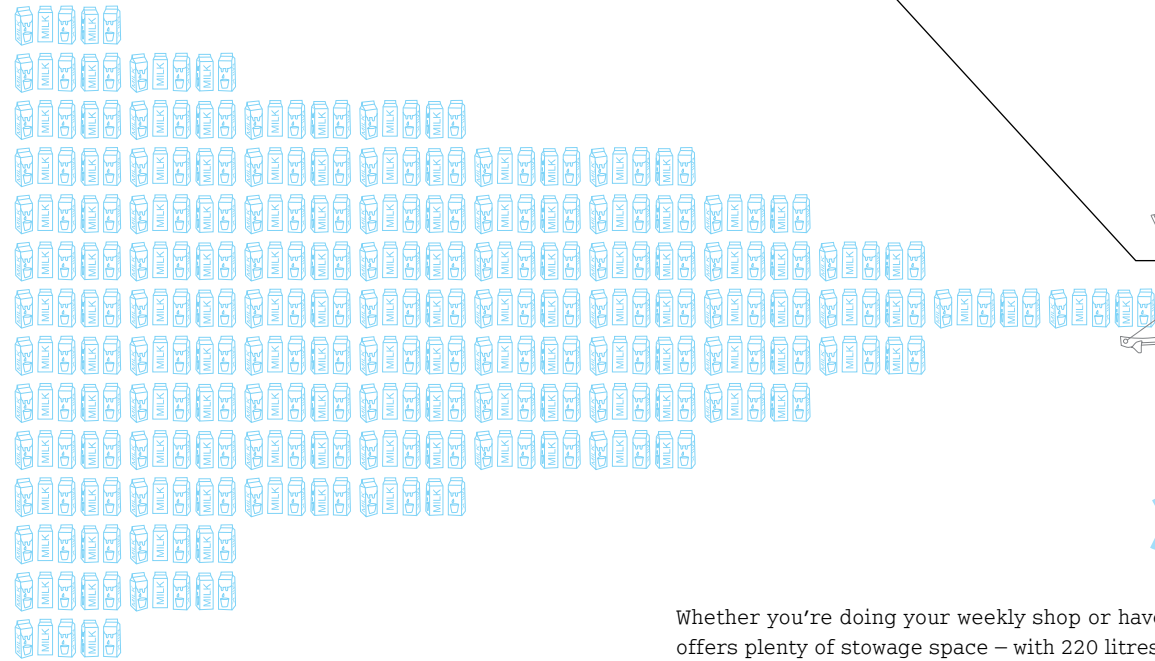

340 litres

Whether you're doing your weekly shop or have an oversized sports bag, the smart fortwo offers plenty of stowage space – with 220 litres of volume up to the top edge of the luggage compartment and 340 litres all the way up to the roof.

>> Generous luggage compartment.

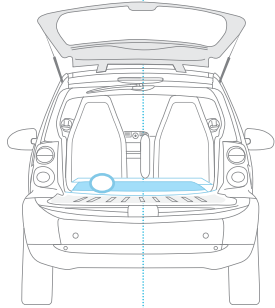

The folding passenger seat makes it easy to transport longer items.



A whole week's shopping can fit effortlessly into the smart fortwo.

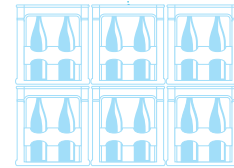

The luggage compartment of the smart fortwo can hold up to six standard drinks crates.



Why not put the luggage compartment capacity to the test and see for yourself? You'll be surprised how much a smart fortwo can hold.

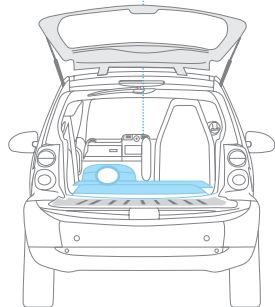

>> Clever everyday solutions.

Life is complicated enough already, so simplicity is always something to be cherished.

For instance, the windscreen wipers with speed-sensitive interval wiping, or the rear windscreen wiper that switches on automatically when reverse gear is engaged and the front windscreen wiper is in operation.

The twin-section tailgate allows you to comfortably load heavy items onto a level surface without needing to bend your back. While the central locking function can be conveniently activated by radio remote control even from the other side of the street.

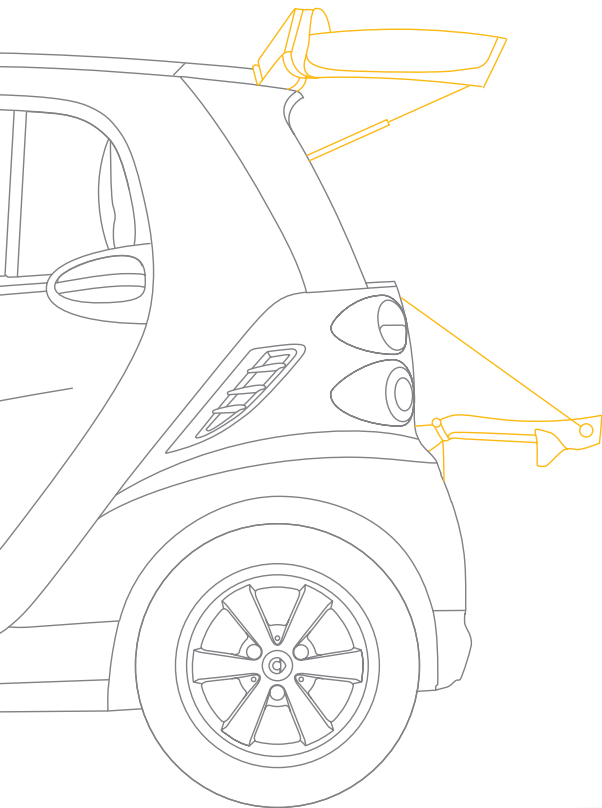

Twin-section tailgate: you can unlock the glass rear window of the coupé from a distance and load heavy items through the top window without having to open the tailgate.

smart
CITY SOLUTION

Twin-section tailgate.

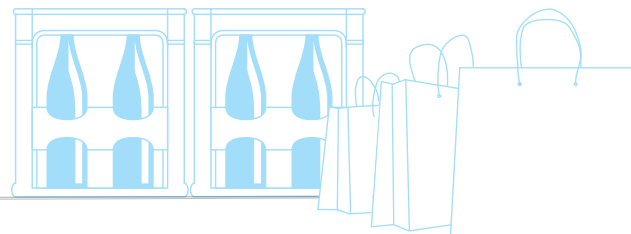

smart CITY SOLUTION

Hill start assist.

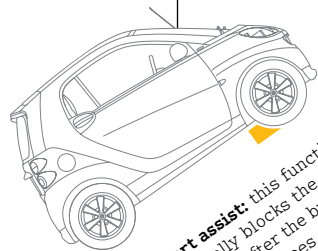

Hill start assist: this function automatically blocks the wheels momentarily after the brake pedal is released on slopes and prevents the car from rolling backwards.

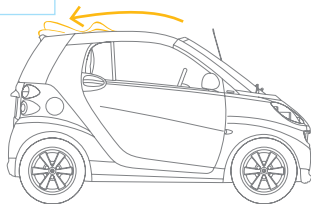

Remote roof release: you can open the cabrio's soft top from a distance and enjoy that open air feeling.

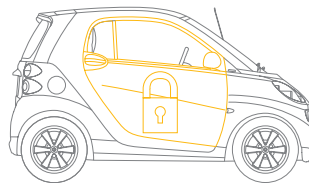

Drive lock function: locks the doors automatically when you drive off.

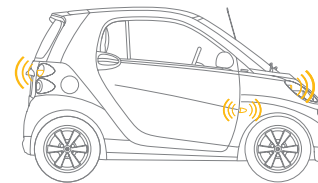

Indicators with lane-changer function: simply tap the indicator lever once and the smart fortwo will indicate three times. Ideal for changing lanes in busy traffic.

>> Change gear by tapping.

The smart fortwo has a clutchless automated manual 5-speed transmission that takes the strain out of gear shifting.

With the softip manual gear-shifting function, simply tap the gear lever forwards (+) to shift up a gear and backwards to shift down again (-). The automatic kick-down function allows you to shift down one or two gears at any time by pressing the pedal to the floor. If you want to take it easy, you can leave the gear-changing to the softouch automatic gear programme.

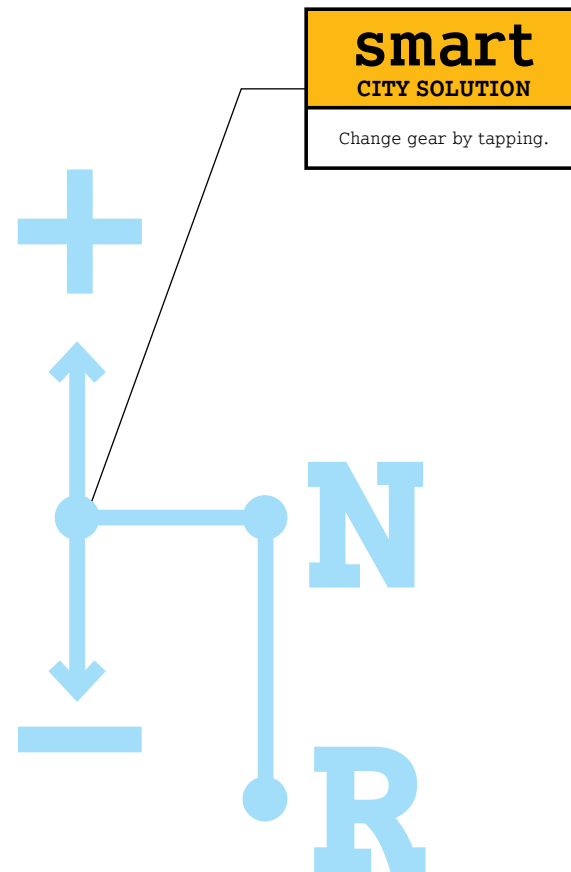

#1: softip:

softip enables you to change gears manually, without using a clutch. A gentle tap on the gearshift lever is all it takes to shift up or down a gear. softip is a standard feature.

#2: softouch:

softouch automatic gear programme can be activated at the touch of a button, and the shift point is then selected automatically.

You still have the option of changing gears manually and switching to softip mode. softouch is an optional feature available at an additional charge.

#3: Steering wheel gearshift:

In softip mode, you change gears using the shift paddles on the 3-spoke leather sports steering wheel, without having to take your hands off the wheel. Steering wheel gearshift is a standard feature.



03 Environment.

The smart fortwo mhd featuring ECO stop/start technology is designed for the frequent stop-and-go of city traffic, reducing both CO₂ emissions and fuel consumption.

>> A little goes a long way.

Lower fuel consumption means a higher driving range than many other cars despite the small tank. With the smart fortwo 52 kW for instance, you can clock up 800 kilometres (52 kW; highway) before you need to refill. Filling up doesn't take long either, with the smart fortwo's 33 litre tank.

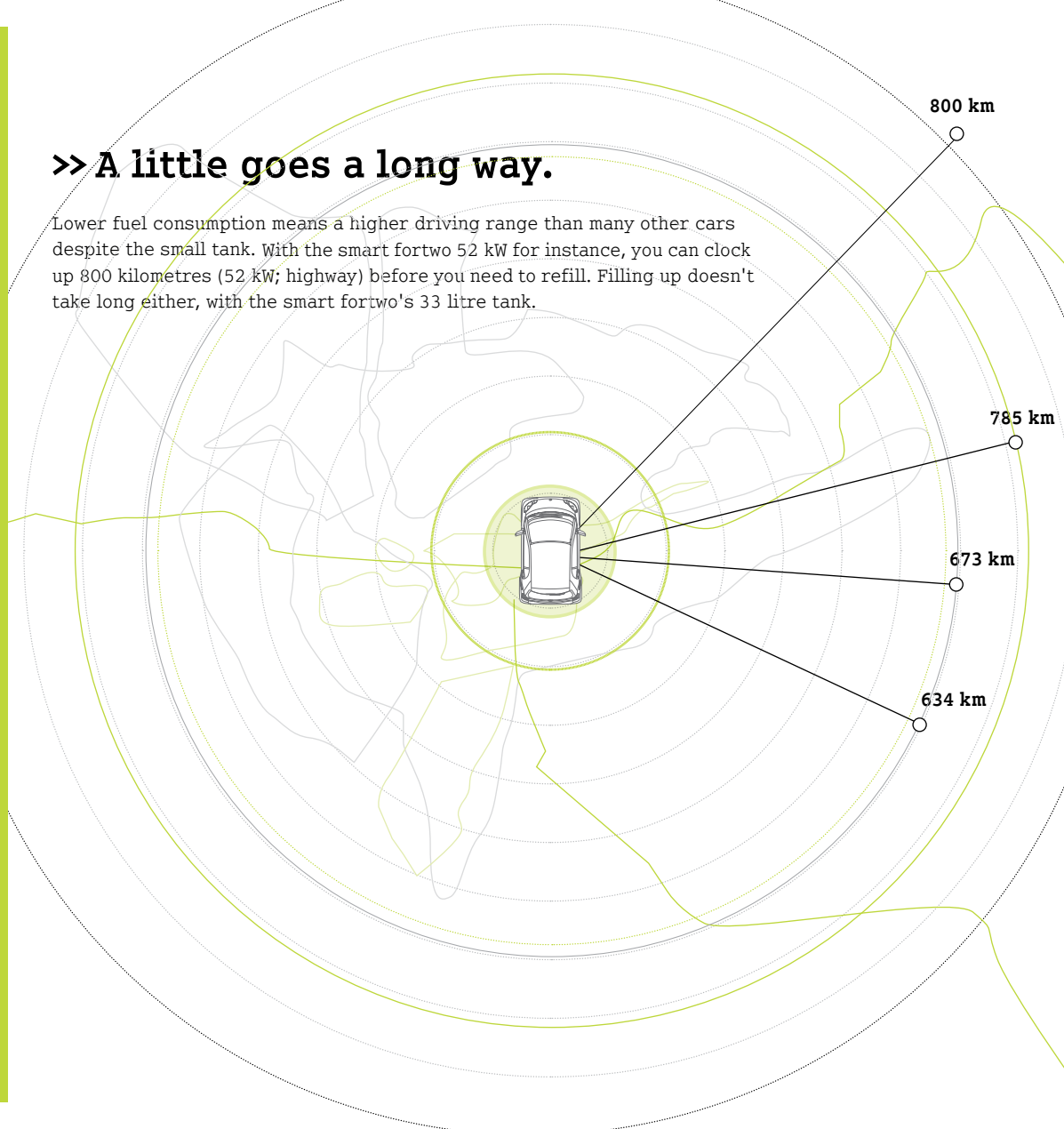

01 Lightweight.

The smart fortwo's high quality plastic bodypanels are lightweight in design and helps to keep the overall weight low, which in turn keeps fuel consumption and costs at a minimum.

02 Practical.

Small bumps can happen, especially when driving in the city. In most cases, the flexible smart bodypanels emerge unscathed; but if worst comes to worst, they can be easily replaced.

01

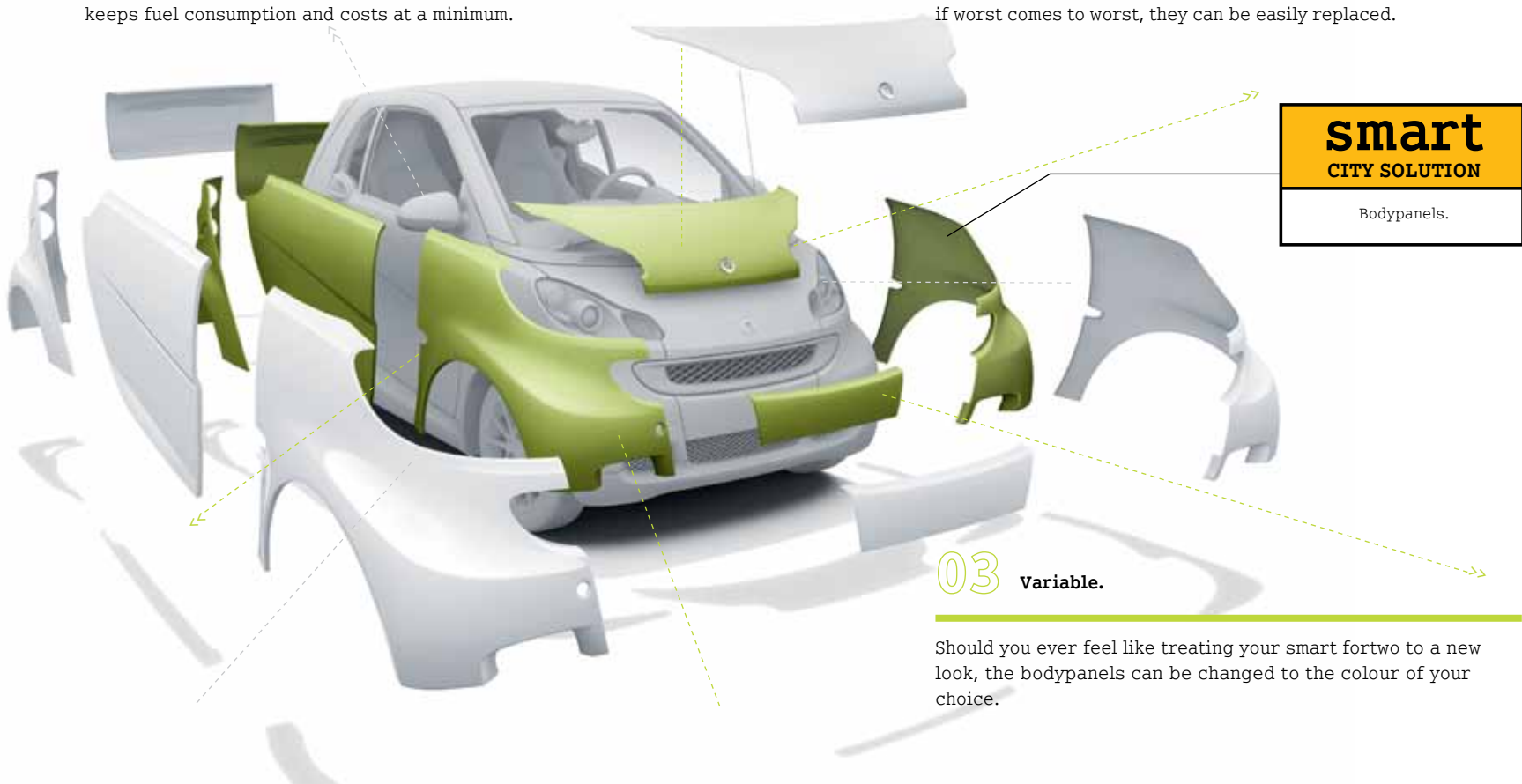

smart CITY SOLUTION
Bodypanels.

03 Variable.

Should you ever feel like treating your smart fortwo to a new look, the bodypanels can be changed to the colour of your choice.

04 Safety.

>> smart safety concept.

Building a car that is small, compact and comfortable is a challenge in itself. A small car offering a level of safety that easily compares with a large car, is due to the innovative safety concept consisting of numerous individual safety elements that act together for maximum effectiveness.

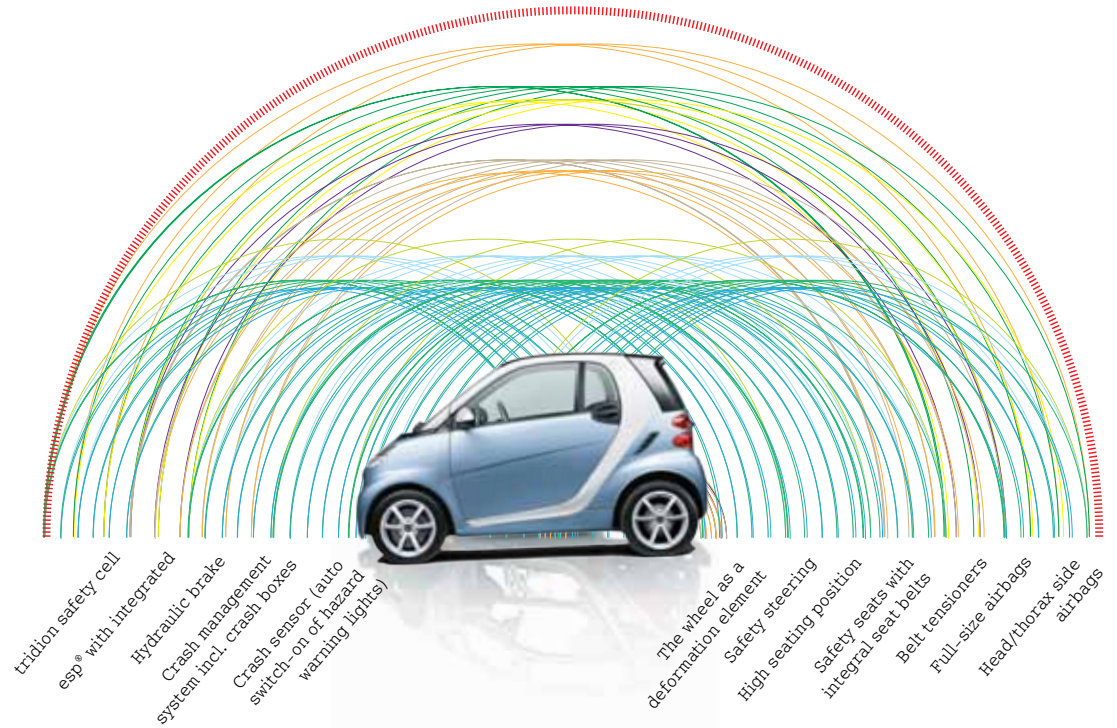

>> Passive safety.

The smart fortwo has a technically sophisticated safety concept with numerous intelligent safety features to protect the occupants in emergency situations. At the heart of the smart's passive safety concept is the tridion safety cell. It offers maximum stability in an ultra-compact design, and provides protection by keeping deformation of the passenger compartment to an absolute minimum.

smart
CITY SOLUTION

Tridion safety cell.

The tridion safety cell is additionally reinforced with high-strength steel sheets at strategically important points. The impact energy is distributed evenly over the longitudinal and transverse members and so effectively reduced.



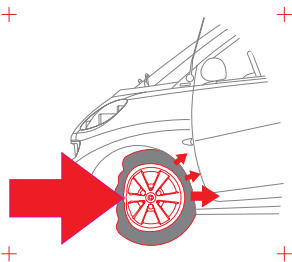

The wheel as a deformation element: in a head-on collision, the front wheel is supported by the side member, thus absorbing a substantial proportion of the impact energy.

The short wheelbase means that the other vehicle involved in a side-on crash will almost always hit the wheel and the suspension components behind.

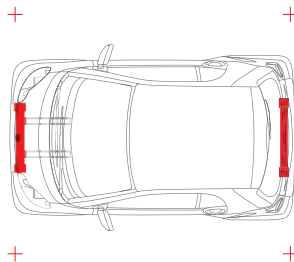

Crash boxes: steel deformation elements at the front and rear absorb the energy from minor collisions at low speeds, and ensure that the tridion safety cell itself remains undamaged.

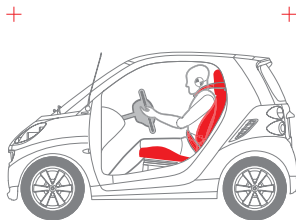

Safety seats with integral seat belts and belt tensioners: the sheet steel structure with integrated headrests lends these seats a high level of mechanical stability. In a frontal impact the belt tensioner will help reduce any slack in just a few milliseconds. The belt-force limiter then help reduce the force again in a controlled manner in order to minimise pressure on the chest area.

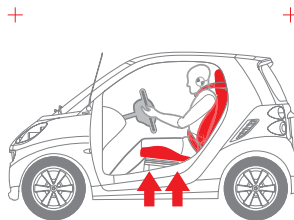

High seat position: not only gives you a better view of what's happening on the road, but also keeps you safe, because in a crash you are generally above the direct danger zone.

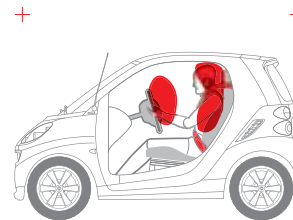

Full-size airbags and head/thorax side airbags: in a frontal impact two full-size front airbags offer maximum protection for driver and passenger.

In the event of a side-on impact, the robust steel door structure and head/thorax side airbags afford additional protection for the head and chest.

>> Active safety.

It's good when an accident doesn't do any damage. It is even better if the accident can be prevented in the first place.

The smart fortwo comes with active safety systems, to help prevent dangerous situations before they arise. The electronic stability programme (esp®) helps to stabilise the vehicle, whilst the anti-lock braking system (abs) optimises braking and swerving manoeuvres.



esp®: when the vehicle is in danger of swerving, the electronic stability programme (esp®) throttles the engine torque and brakes individual wheels in order to prevent the car from breaking away.

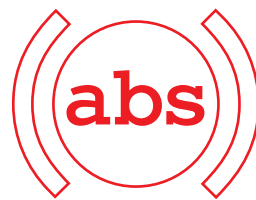

abs: as part of the electronic stability programme (esp®), the anti-lock braking system (abs) keeps you in control even during emergency braking. The electronics prevent the wheels from locking, enabling you to continue steering safely whilst applying the brakes.

Hydraulic brake assist: if you step on the brakes quickly but not firmly enough in a dangerous situation, hydraulic brake assist will help you by initiating controlled emergency braking.

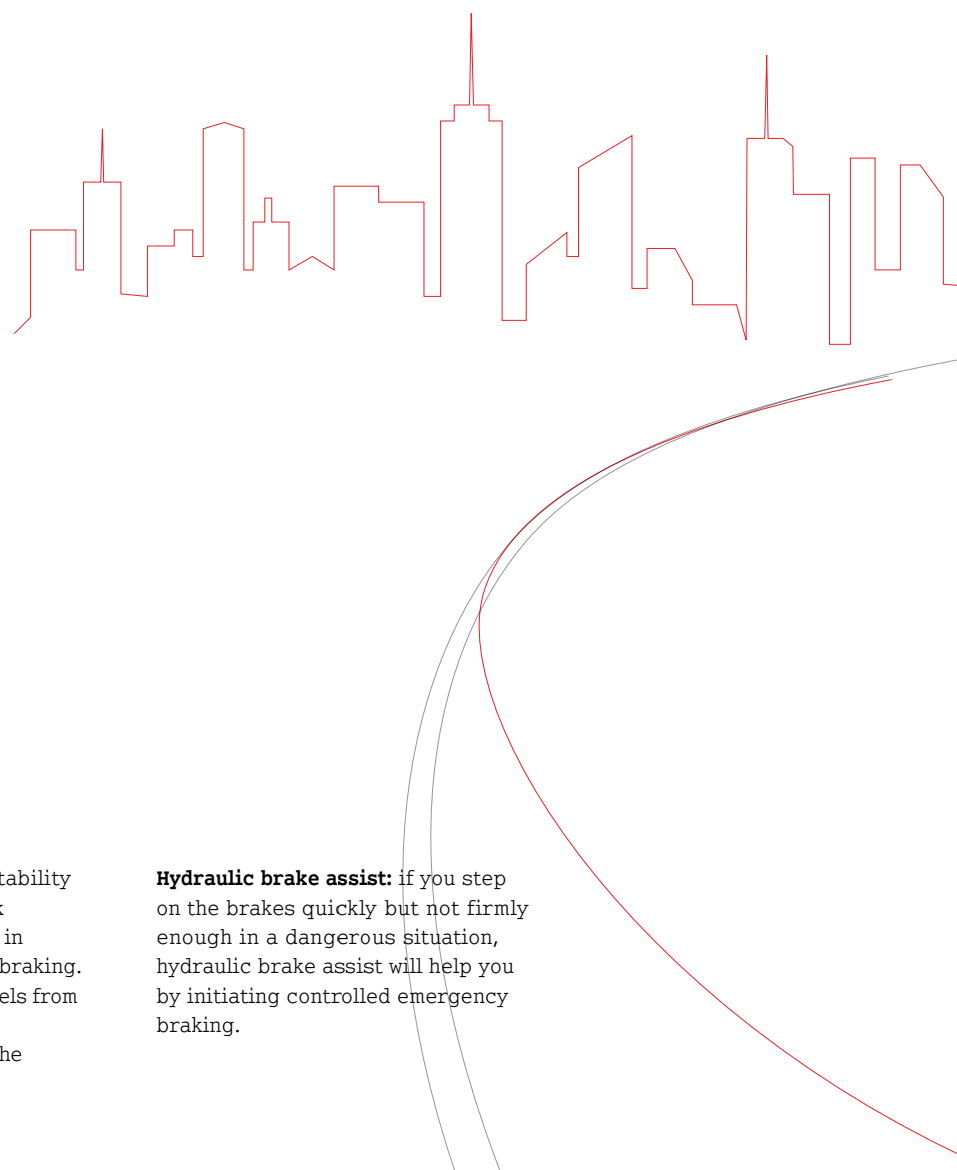

05 Models.

People are as different as the cities they live in. Some focus on practicality and simply getting from A to B, whilst others find that a wide range of equipment, comfort or a more powerful engine is important.

>> The smart fortwo pulse.





Front fog lights: a sporty detail that also ensures perfect visibility in bad weather.

dynamic styling: the aprons and side skirts are finished in the bodypanel colour underlining the sporty look.

3-double-spoke alloy wheels 38.1 cm (15") with wide tyres: (175/55 R 15 at the front and 195/50 R 15 at the rear).

tridion safety cell in black: also optionally available in silver or white. The door mirror caps and radiator grille are finished in the same colour.

Engines:
> 52 kW (71 hp) petrol engine (mhd)
> 62 kW (84 hp) petrol engine (turbo)

Upholstery: the mix of fabric and leather optic provides for a dynamic look and sporty seating comfort. The fabric elements on the instrument panel, door trim and knee pad are colour-coordinated with the upholstery.



Dashboard instruments: the cockpit clock and rev counter are illuminated from the inside. They can be swivelled and lend the cockpit even more sportiness.



Electric windows: with one-touch control on the driver's side.



Panoramic roof (coupé; incl. sunblind): made of break-resistant tinted polycarbonate.



3-spoke leather sports steering wheel with steering wheel gearshift (incl. leather gear knob): your hands stay on the steering wheel whilst changing gear.

softip – manual gear programme (not shown): manual gear changing without the need for a clutch. Lightly tap the gear lever, or using the shift paddles on the steering wheel.

>> Features.

Panoramic roof (coupé, incl. sunblind)

Tridion safety cell in black, optionally available in silver or white

Door mirror caps & radiator grille in the colour of the tridion safety cell

Four 3-double-spoke alloy wheels (R22) 38.1 cm (15") with wide tyres, front: 175/55 R 15; rear: 195/50 R 15

Bodypanel plus sports package (dynamic front and rear apron and side skirts finished in the bodypanel colour)

Front fog lamps

Pulse logo in mirror triangle

3-spoke leather sports steering wheel with steering wheel gearshift (incl. leather gear knob) softtip – manual gear shifting (shift lever and additional shift paddles on steering wheel)

Electric windows

Dashboard instruments (cockpit clock and rev counter)

Upholstery: fabric/leather look; colour: black

Contrast components in the colour: pearl black

Fabric elements on instrument panel, door trim and knee pad; colour-coordinated with upholstery



>> smart fortwo coupé or cabrio.



The smart fortwo coupé.

smart fortwo coupé drivers can enjoy a view of the sky with the large panoramic roof made of break-resistant polycarbonate.

The integrated sunblind protects you from too much sun when necessary, and the storage compartment in the tailgate provides extra space where there wouldn't normally be any. The coupé is also available with a sturdy plastic, solid black roof.



The smart fortwo cabrio.

You decide how much summer you want with the fully automatic tritop fabric soft top. Simply press a button to open and close the folding top in a matter of seconds. With the 3-button key you can open the soft top from a distance, and for maximum freedom, you can even remove the roof bars..

Three attractive colours for the soft top make the cabrio an eye-catcher, even when the sun isn't shining. If needed, the rear window made of scratch-resistant safety glass can be heated for better rear visibility.



smart
CITY SOLUTION
Fully automatic tritop
fabric soft top.



>> Standard features (coupé & cabrio).

Functional/electrical

Automated manual 5-speed transmission with kickdown function

Central locking with radio remote control and immobiliser; incl. locking of filler cap

Instrument cluster with multifunctional display (digital gear display with gear recommendation, fuel gauge with reserve indicator, service interval indicator, trip recorder, clock)

Exterior temperature indicator with frost warning

Indicators with lane changer function

Comfort windscreen wipers with speed-sensitive interval wiping and automatic wipe/wash function

Rear window wiper with interval wiping, automatic wipe/wash function, automatically switched on when reversing (coupé)

Headlamp range adjustment (manual)

Heated rear window

One-hand operation of tailgate, with electric rear window release (coupé)

Rear window release (coupé) or remote roof release (cabrio) via 3-button key

12 volt socket with cover

Audio system with RDS radio and AUX/USB input

Safety

Electronic stability programme (esp®)

Anti-lock braking system (abs) with electronic brake force distribution

Full-size driver and passenger airbag

Tridion safety cell

Safety seats with integral seat belts

Seat belts with belt tensioners and belt force limiters

Hydraulic dual-circuit brake system with servo assistance

Hydraulic brake assist

Crash elements at front and rear

Crash sensor

(auto switch-on of hazard warning lights)

Drive lock – automatic door locking when the vehicle is in motion

Automatic hill start assist (on uphill slopes)

Exterior

Bodypanels in deep black or crystal white

Fuel filler cap finished in the bodypanel colour

H7 projection headlights

White side indicators

Service flap

Third brake light

Interior

Passenger seat backrest can be folded right down for through-loading

Storage compartments on passenger side and next to steering wheel

Net pockets in doors and sides of seat backrests

Interior lighting

Make-up mirror in passenger sun visor

Storage compartment in tailgate



>> Mix and match colours.

The range of colours available for the smart fortwo also shows that it is a very special car. You can combine the three colours available for the tridion safety cell with six bodypanel colours.



□ tridion safety cell in black



○ tridion safety cell in silver



○ tridion safety cell in white



crystal white

deep black

silver metallic



light blue metallic

grey metallic

matt light green

tritop fabric soft top
in black, red or blue

06 Options.

You can tailor your smart fortwo perfectly to your needs. Decide how much sportiness, elegance, comfort and functionality you want from your smart.

>> Optional exterior equipment.



Fully automatic tritop fabric soft top with heated glass rear window (cabrio): available in black, red or blue.

Tridion safety cell in white, black or silver: the expanded range of colours for the tridion safety cell opens up even more possibilities for combinations with the bodypanel colours.

LED daytime driving lights: see and be seen with these elegant daytime driving (high)lights.

6-spoke alloy wheels (R67):
38.1 cm (15") with wide tyres
measuring 175/55 R 15 at the
front and 195/50 R 15 at the
rear.



**3-double-spoke alloy wheels
(R23):** 38.1 cm (15") with wide
tyres measuring 175/55 R 15
at the front and 195/50 R 15
at the rear.

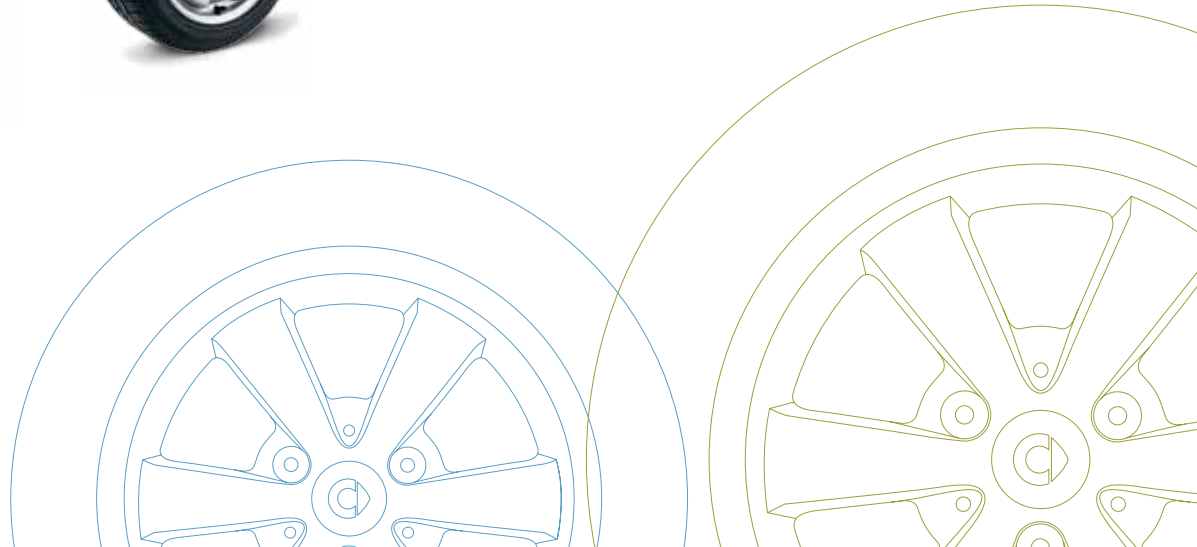

>> Optional interior equipment.

Ambient lighting: six dimmable LEDs and two additional lights in the footwell bring out the best in night-time driving.



Leather look seats¹: the seats with integral seat belts in black leather look elegant and are extremely comfortable.



Folding armrest for the driver's seat: for even greater comfort. Available in imitation leather or covered with fine fabric.

Heated seats: two settings with automatic switch-off function.



¹Imitation leather on the seat bottom and in the top area of the rear of the backrest.

>> Optional functional & electrical equipment.



Cruise control: easy to operate via paddles on the steering wheel and available in the assistance package.

Power steering: enjoy extra comfort at the wheel and manoeuvre your smart fortwo effortlessly into even the smallest parking spaces.



Trip computer: the easy-to-read multifunctional display shows current fuel consumption, trip kilometres, trip information and more and is operated via the steering column control stalk.



Anti-theft alarm system.

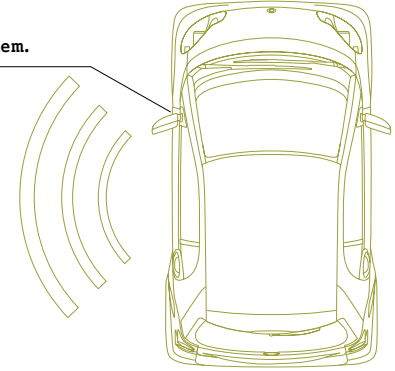

Electrically adjustable and heated door mirrors: for a clear view at all times.



softtouch automatic gearshift programme: for greater comfort in urban traffic. Switch between manual and automatic gear shifting at the touch of a button.

>> Optional audio & sound equipment.

Sound system: compatible with all smart radios. Two tweeters, two mid-range speakers and a subwoofer provide for top sound quality.

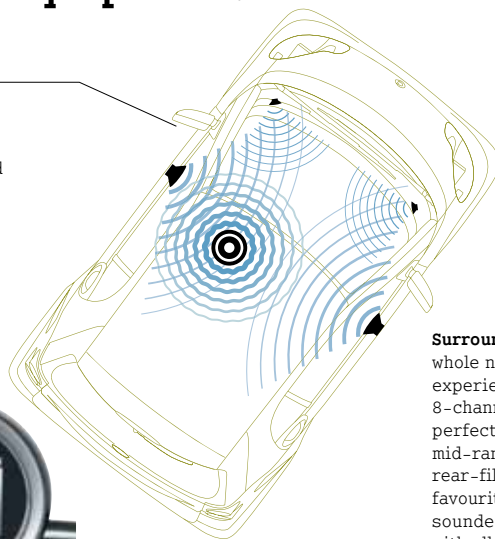

Surround sound system: for a whole new full-sound experience. With subwoofer, 8-channel digital amplifier and perfectly matched tweeters, mid-range speakers and rear-fill loudspeakers, your favourite songs have never sounded so good! Compatible with all smart radios.

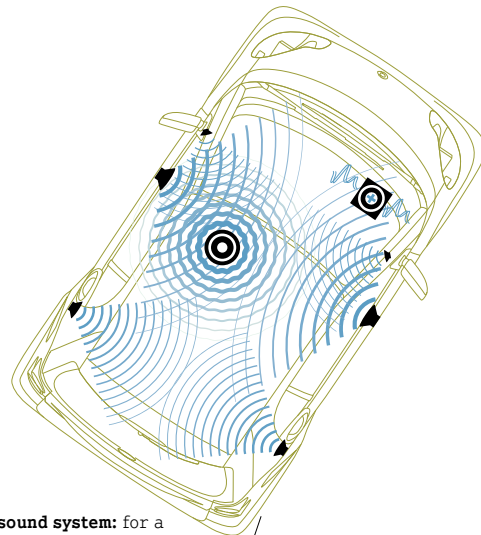

smart Bluetooth® hands-free system: lets you make phone calls while keeping both hands on the wheel, thanks to unobtrusively integrated Bluetooth® technology. With wireless controller on the centre console and voice and sound output via the vehicle's loudspeakers.

>> Optional luggage and stowage.

Luggage compartment cover (retractable, incl. net bag): protects luggage from prying eyes and sunlight. The net bag on the outside is within easy reach of the driver and passenger.



Breakdown kit: thanks to air compressor and sealant you'll be back on the road in no time after a flat tyre – without having to remove the wheel.

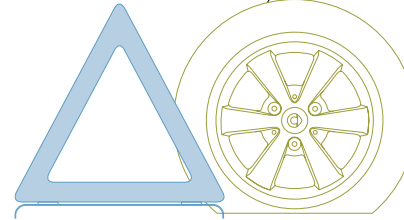

Storage box on centre console: the ideal place for everything that needs to be kept within easy reach.



Cupholder: this practical plastic holder will even hold a 1.5 litre bottle securely.

>> Equipment packages.



Primo package.

- > softpouch - automatic gear programme
- > Leather seats
- > Assistance package (Cruise control and trip computer)
- > Surround sound system (2 tweeters, 2 mid-range, 2 rear-fills, subwoofer, digital amplifier)
- > Electrically adjustable and heated door mirrors



Assistance package.

Included in the Primo Package, the assistance package supplies you with all the information you need on the road and offers quick and simple operation.

For a relaxing journey:

- > Cruise control
- > Trip computer

07 Service & accessories.

>> Your authorised smart centre.

To really get to know the smart fortwo, you need to experience it first hand. Visit your authorised smart centre, take a seat and find out all there is to know about the smart fortwo, its equipment, and all the extensive accessories.

Of course, we will also be pleased to answer all your questions on financing, leasing and the extensive range of smart services. Your authorised smart centre – we're here to help you.

>> Leasing and financing.

Not only are we accommodating and flexible in putting together your own personal smart fortwo, but we can also help you when it comes to financing.

Mercedes-Benz Financial specialises in providing a full range of high quality finance and insurance products.

Choose from a range of attractive finance and insurance packages offered that best suit your needs. Whether you are leasing or financing, our comprehensive product range means you can find the ideal financial solution just for you.

Mercedes-Benz Financial

www.mercedes-benz.com.au/finance

*Mercedes-Benz Financial is a registered business name of Mercedes-Benz Financial Services Australia Pty Ltd ABN 73 074 134 517, AFSL No. 247271. All finance products are subject to credit assessment criteria. Before purchasing any insurance products please refer to the Product Disclosure Statement and Policy Wording booklet for full terms and conditions.

>> smart services.

Should a problem arise with your smart fortwo, we'll make sure it's back on the road before long. Our workshops pursue a process-orientated, efficient approach, employing state-of-the-art facilities. Using smart genuine parts, which are tailored to your smart fortwo, you can be sure they meet the high quality standards of Mercedes-Benz.

For a long service life and a high level of vehicle safety.

smart service - maximum maintenance at minimum costs. The smart fortwo with a naturally aspirated engine only requires servicing every 12 months/20,000km. For turbo charged vehicles the service interval is 12 months/15,000kms.

The **smart warranty** will make you feel even better about your smart, providing a three year warranty from the date of the first registration, with unlimited kilometres.

smartmove Assistance applies for three years from the date of first registration, while under the factory warranty cover and is offered to provide owners with assistance in case of a breakdown anywhere in Australia, 365 days a year.

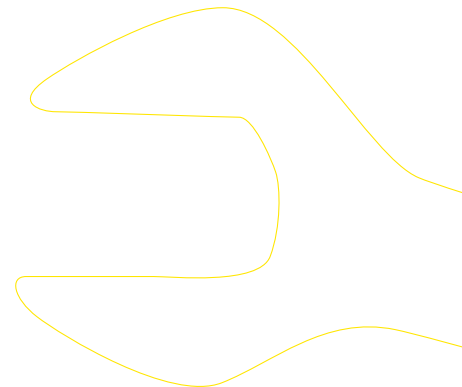

>> smart accessories.

Whenever you feel like giving your smart a treat, pay a visit to your authorised smart centre. There you will find all sorts of things to make your car even more attractive and unique.

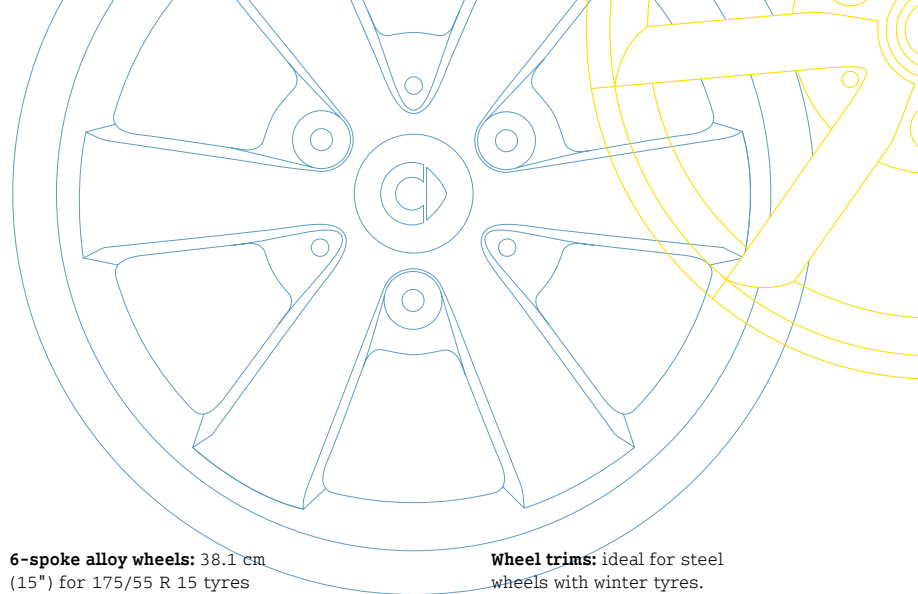

9-spoke alloy wheels: 38.1 cm (15") for 155/60 R 15 tyres at the front and 175/55 R 15 tyres at the rear.



6-spoke alloy wheels: 38.1 cm (15") for 155/60 R 15 tyres at the front and 175/55 R 15 tyres at the rear.



6-spoke alloy wheels: 38.1 cm (15") for 175/55 R 15 tyres at the front and 195/50 R 15 tyres at the rear.



6-spoke alloy wheels: 38.1 cm (15") for 175/55 R 15 tyres at the front and 195/50 R 15 tyres at the rear.



6-double-spoke alloy wheels: 38.1 cm (15") for 175/55 R 15 tyres at the front and 195/50 R 15 tyres at the rear.



Wheel trims: ideal for steel wheels with winter tyres. Protect rims and bolts against the weather.

Set of chrome look indicator lamps: reflective bulbs brilliantly complement the chrome finish.

Chrome-plated recessed door handles: a visual and haptic highlight.

Chrome package: add a special touch to your door mirror caps, radiator grille and tailgate trim.

Fog light rings: highly polished chrome-plated fog light rings.

6-spoke alloy wheels in chrome look: 38.1 cm (15") for 175/55 R 15 tyres at the front and 195/50 R 15 tyres at the rear.

Bodypanels: unique to the smart fortwo, the exchangeable body parts are available in nine attractive colours.



All-weather floor mats: non-slip, dirt and water repellent, easy to clean rubber floor mats.



Ribbed floor mats: for the driver who wants it all. These polypropylene fibre ribbed floor mats are robust, yet create a pleasant touch to your smart fortwo.



Velour floor mats: with the smart logo and new tone-in-tone stitching, these mats fit perfectly in the footwell and harmonise with all interior colours. A high-quality, hard-wearing highlight.



Seat covers: come in a set of two. Designed to ensure your seats stay looking new for a long time to come. In addition, the pockets on the rear of the backrest and in the footwell offer practical storage space.



Mud flaps: keep your smart and the traffic behind you clean even in bad weather, by directing mud and grit back down onto the road.

>> smart rear rack systems.



Basic rack: holds rack systems for a range of sporting equipment. The rear window can also be opened even when the rack is loaded.



Ski and snowboard rack: available separately or can be combined. With space for up to two pairs of skis plus a snowboard. Skis and snowboard not included.



smart bike rack: ideal when you want to switch from four wheels to two. Simply insert your bicycle into the rack system and secure it with the lockable frame holder. Bicycle not included.

>> smart luggage compartment accessories.

smart offers one thing above all else: more room for good ideas. From the luggage fastener, to storage boxes or a coolbag, practical luggage compartment accessories ensure that your smart fortwo is ready for anything.

Boot tray: this waterproof tray protects your luggage compartment from spills and dirt.



Net set for luggage compartment: two nets to keep a firm hold on your luggage. One on the side of the luggage compartment and one on the floor.



Luggage compartment management system: flexible cargo system with slot-in sections, enables the luggage compartment to be partitioned as required. Shopping can also be secured in place using an elastic strap and a shopping (trolley) bag. Groceries not included.



Coolbag: keeps food and drinks cold, helping you to keep your cool.



Luggage fastener: this elastic foam snake fits around items in the luggage compartment and keeps them in place during cornering and braking.

Safety plus package for the tailgate compartment: for your safety should things go wrong. A fluorescent jacket, hazard warning triangle, first-aid kit, torch, ice scraper, umbrella and replacement lamp box means you are always ideally prepared.



Multifunctional box: the insulated multi-functional box keeps cold things cold and hot things hot.



>> The smart merchandise collection.



#1



#2



#4



#3

#1. polo shirt for women:
asphalt, made of 100 % cotton, tailored fit, with pink accents and embroidery on the front and back, gathered sleeves and breast pocket. Sizes: XS-XL
B6 799 3491-3495

#2. cap for women:
asphalt, made of 100 % cotton, with pink accents, embroidered pictogram, fastener with embossed ring logo, "open your mind." on the peak and strap. Adjustable
B6 799 3548

#3. smart BRABUS reporter bag:
black, 100 % polyester, with red accents, ring logo embossed on the front and BRABUS on the back, padded laptop compartment and padded shoulder strap.
Dimensions: 45x30x13 cm
B6 799 3515

#4. smart BRABUS polo shirt for men: black, made of 100 % cotton with red accents and breast pocket and red BRABUS branding on the back, "open your mind." printed on the sleeve, black ring logo on the chest. Sizes: S-XXL
B6 799 3461-3465



#5

#5. track jacket for men:
black, made of 100% polyester, with urban colour print on the front and "open your mind." embroidered on the back. Sizes: S-XXL
B6 799 3446-3450



#6

#6. flip flops:
black, made of skin-friendly EVA and nubuck polyurethane, unisex, with turquoise contrast in sole, white prints and pictogram as a profile. Sizes: XS-XL corresponds to EUR 37-46
B6 799 3534-38



#7

#7. hooded sweatshirt for men:
black, made of 70% cotton and 30% polyester, with turquoise accents, embroidery on the front and sporty button row. Sizes: S-XXL
B6 799 3481-3485



#8

#8. volleyball rucksack:
black, 100% polyester, with turquoise accents, padded back with breathable 3D air-mesh cover, stowable volleyball net for securing a ball, spacious main compartment, zipped inner pocket and net side pockets. (Volleyball available separately). Capacity: 20 l
B6 799 3510



08 Overview.

>> The engines.

smart fortwo coupé	pulse
Petrol mhd, 52 kW (71 hp) 3-cylinder in-line engine, 999 cc	<input type="checkbox"/>
Petrol turbo, 62 kW (84 hp) 3-cylinder in-line engine, 999 cc	<input type="checkbox"/>

smart fortwo cabrio	pulse
Petrol mhd, 52 kW (71 hp) int in-line engine, 999 cc	<input type="checkbox"/>
Petrol turbo, 62 kW (84 hp) 3-cylinder in-line engine, 999 cc	<input type="checkbox"/>

Standard equipment



>> The colours.

smart fortwo coupé/cabrio	pulse
bodypanels	
crystal white	□
deep black	□
silver metallic	○
light blue metallic	○
grey metallic	○
matt light green	○
tritop fabric soft top (cabrio)	
black	□
red	○
blue	○
tridion safety cell	
black	□
silver	○
white	○
upholstery	
fabric/leather look; black	□
leather seats (black)	○

□ Standard equipment

● Available as an option at no extra cost

○ Available as an option at an additional charge

– Not available

>> Technical data.

	> Petrol engine 52 kW (71 hp) coupé & cabrio mhd	> Petrol engine 62 kW (84 hp) coupé & cabrio turbo
Engine type	3-cylinder in-line engine	3-cylinder turbo in-line engine
Engine capacity in cc	999	999
Max power in kW (hp) at rpm	52 (71)/5,800	62 (84)/5,250
Max torque in Nm at rpm	92/4,500	120/3,250
Maximum speed in km/h	145	145
Acceleration 0-100 km/h in s	13.3	10.9
Fuel consumption, urban cycle	4.7	6.3
Fuel consumption, extra-urban cycle	4.1	4.1
Fuel consumption, combined cycle ²	4.4	4.9
Fuel type	Premium unleaded ¹	Premium unleaded ¹
Exhaust gas purification/exhaust gas standard	3-way catalytic converter/EU4	3-way catalytic converter/EU4
CO ₂ emissions (combined) in g/km	100	115
Vehicle length/width/height in mm	2,695/1,559/1,542	2,695/1,559/1,542
Wheelbase in mm	1,867	1,867
Turning circle in m	8.75	8.75
Luggage compartment capacity in l	220-340 ³	220-340 ³
Tank capacity/of which reserve in l	33/5	33/5
Kerb weight/payload in kg	coupé: 750/270; cabrio: 780/240	coupé: 770/280; cabrio: 800/250

¹ Premium unleaded = lead-free 95 RON

² Fuel consumption will vary depending on driving conditions/style, vehicle conditions and options/accessories. Source of fuel consumption data: ADR 81/02.

³ Up to roof.

>> www.smartaustralia.com.au

Discover the world of smart.

At www.smartaustralia.com.au you'll find everything about the smart brand and the smart fortwo, further information, and services. It is always worth a visit, and here for you 24 hours a day.

>> smart fortwo.

All the information you need about the smart fortwo, at your fingertips. Here you can find out everything about the different equipment lines, special models, engines and technical features.

Find your local authorised smart centre, arrange a test drive or request a brochure.





>> Information & service.

View information on smart service details, genuine parts and environmental awareness.

>> smart world.

Here you can find out everything about the smart brand above and beyond the vehicle. Including past and present information from the world of smart, current events and a virtual test drive.