



This Service Information bulletin supersedes SI B11 04 13 **dated November 2013**

PERFORM THE PROCEDURE OUTLINED IN THIS SERVICE INFORMATION ON ALL AFFECTED VEHICLES BEFORE CUSTOMER DELIVERY OR THE NEXT TIME THEY ARE IN THE SHOP FOR MAINTENANCE OR REPAIRS.

NEW designates changes to this revision

SUBJECT

Service Action: N14 Engine Check Timing Chain Tensioner and Timing Chain

MODEL

R55

R56

R57

With the N14 engine

SITUATION

The timing chain tensioner applies pre-tension to the timing chain guide rail mechanism. In some cases, the tensioner spring force may be too low. Depending on the severity of the wear, it may lead to a rattling noise when starting the engine cold or when the engine is idling.

CAUSE

The timing chain tensioner internal tolerances are not consistent.

AFFECTED VEHICLES

This Service Action affects certain MINI models equipped with the N14 engine, produced from 11/2006 to 5/2009.

NEW First check the B-pillar Service Action label for code number **61**.

NEW If code number **61** has been punched out, the campaign has already been performed and no further action is necessary.

NEW Vehicles which require this Service Action to be completed will show it as “Open” when checked either in the "Service Menu" of DCSnet (Dealer Communication System) or with the Key Reader.

PROCEDURE

Inspecting the Chain Tensioner:

1. The timing chain tensioner will need to be inspected before removal. The timing chain tensioner is visible from above, inside the engine compartment, between the intake tube and air filter housing. One of the following timing chain tensioners may be installed. **Do not remove the timing chain tensioner for the inspection.**

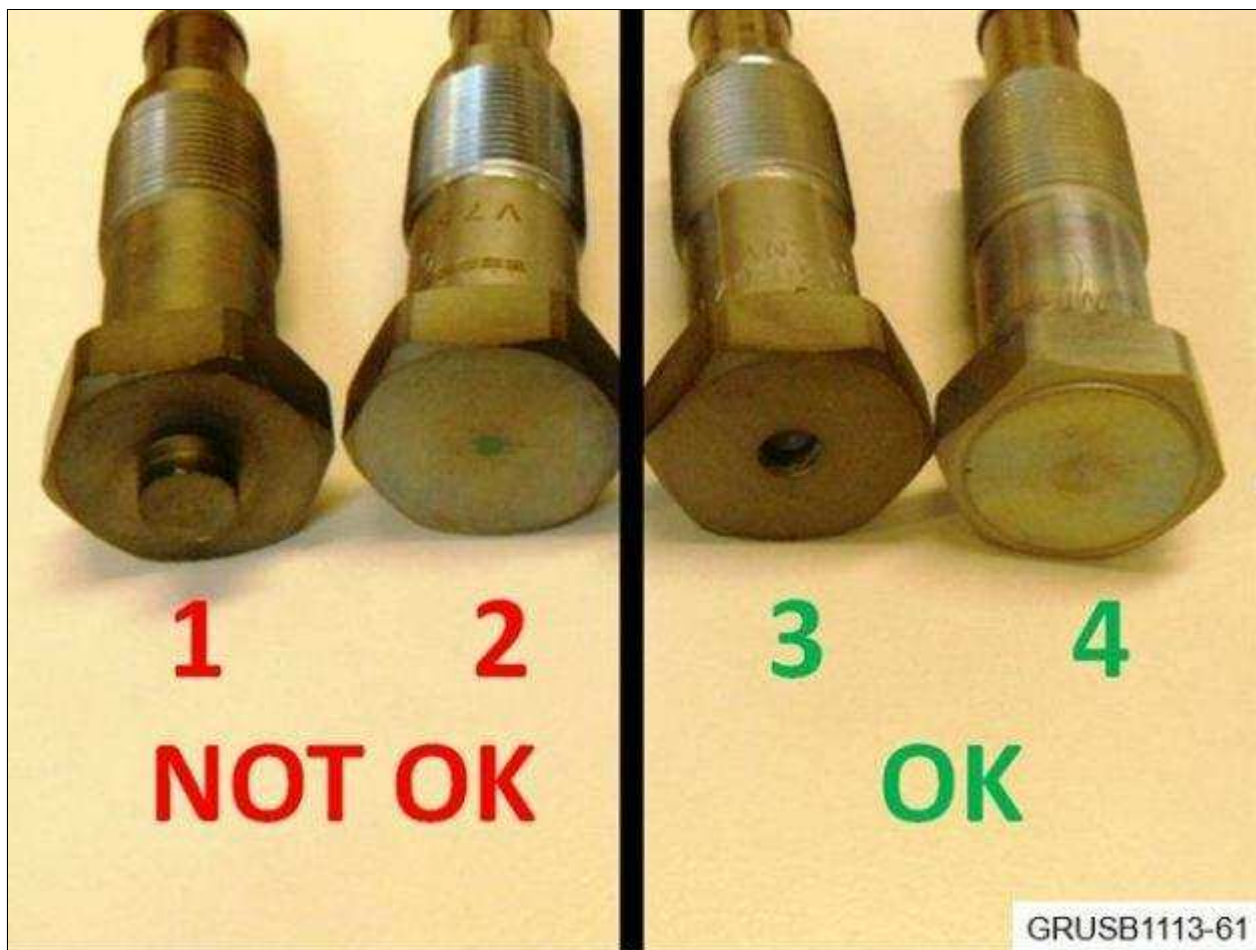

Item 1: Protruding boss – Not OK	Item 3: Drilled head – OK
Item 2: Flat head, no markings, no holes, no machined edge– Not OK	Item 4: Machined edge in head – OK

2. **NEW** If the engine is fitted with a timing chain tensioner that has a drilled head (item 3) or has a machined head (item 4), do not replace the timing chain tensioner. No further repairs are needed. If the chain tensioner has a protruding boss (item 1) or a flat head (item 2), proceed to step 3.
3. Remove the right-hand wheel arch trim to access the crankshaft central bolt.
4. Disconnect the battery and remove the ignition coils and spark plugs. Turn the engine in clockwise direction by hand to move the flywheel approximately 90° before TDC. Rotating the engine counterclockwise may cause an incorrect measurement.

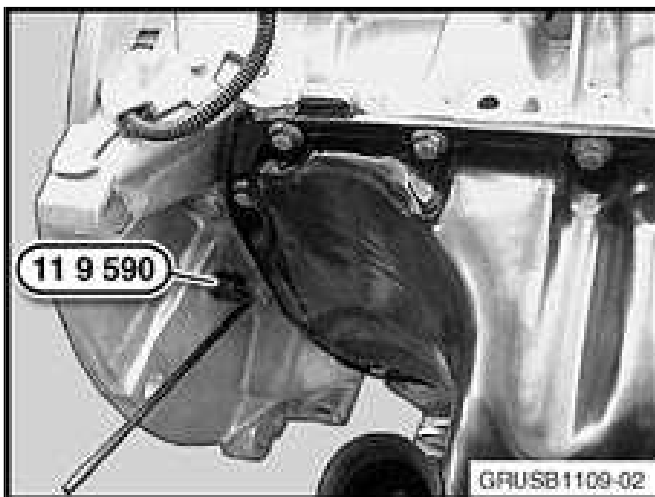

5. Install the locating pin (Special Tool 11 9 590) to lock the position of the engine.

Note:

Do not remove the cylinder head cover!
Do not install the camshaft locking tool during this procedure. To achieve an accurate measurement, the camshafts need to

rotate.

Remove the chain tensioner and collect the residual oil with a shop towel.

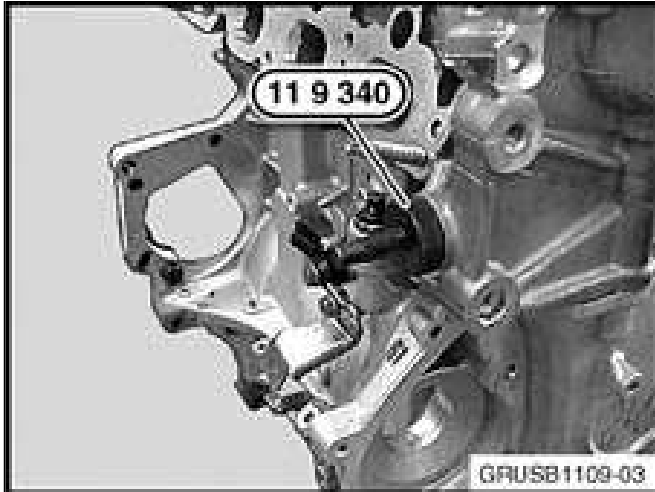

6. Fit the chain tensioner (Special Tool 11 9 340) without the seal ring and with the lock nut loose. Pretension the chain tensioner with Special Tool 00 9 250 to 0.6 Nm. Finger-tighten the M10 lock nut on Special Tool 11 9 340.

Note:

Gently turn Special Tool 00 9 250 while applying the torque. Quickly rotating the tool will provide an inaccurate measurement result.

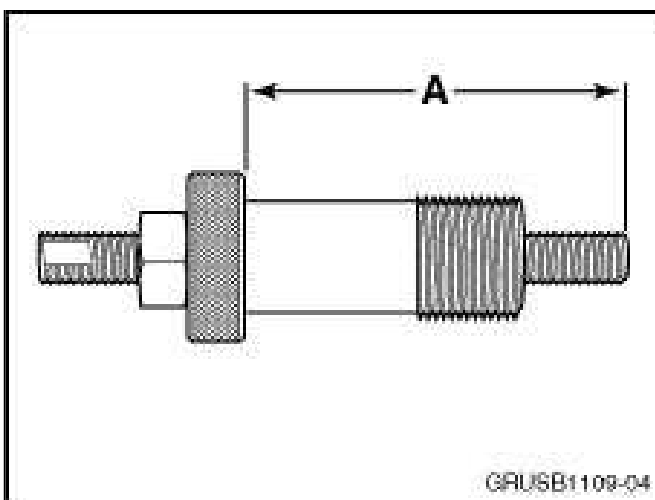

7. Remove chain tensioner Special Tool 11 9 340 from the engine, with the lock nut still tight. Measure the distance (A), as described in the illustration.

8. If distance A is less than 68 mm, replace the chain tensioner with sealing ring P/N 11 31 4 609 482 (refer to parts list A).
9. If distance A is 68 mm or greater, replace the components below, found in the Timing Chain Repair Kit P/N 11 31 8 623 601 (refer to parts list B):
 - Timing chain tensioner
 - Sealing ring
 - Timing chain
 - Guide rail
 - Tensioner rail
 - Sliding rail
 - Sprocket on the crankshaft
 - Bearing bolts for the tensioner and guide rails

Refer to Repair Instruction 11 31 051, “Replacing timing chain N14.”

During the replacement of the timing chain module (guide rails), inspect for missing or broken parts. If portions of or the entire guide rail(s) are missing, it is very likely these component fragments have migrated into the engine oil pan.

In this case, remove the engine oil pan to retrieve the component fragments and replace the engine oil and filter.

Note: If the engine oil service is showing “Recommended” or “Due,” reset the CBS data.

Refer to Repair Instruction 11 13 000, “Removing and installing, sealing or replacing oil pan (N14).” (Refer to parts list B and C.)

Do not replace the front crankshaft hub seal unless it is found to be

leaking or damaged.

Refer to the EPC for additional onetime-use parts as required, e.g., gaskets, seals, bolts, etc.

Do not replace the hydraulic valve lifters (HVA), intake camshaft VANOS adjustment unit, or the exhaust camshaft sprocket for this repair. Refer to the Warranty section of this bulletin for more details.

PARTS INFORMATION

Parts List A		
Part Number	Description	Quantity
11 31 4 609 482	Chain tensioner with seal ring	1
Parts List B		
Part Number	Description	Quantity
11 31 8 623 601	Timing chain repair kit (includes timing chain tensioner and seal ring)	1
Parts List C		
	Removing and Installing Engine Oil Pan	
Part Number	Description	Quantity
11 42 7 622 446	Set oil-filter element	1

and, claim in sublet		
Part Number	Description	Quantity
83 19 0 404 517	Loctite 5970 liquid sealer - 50ml	1
07 51 0 143 829	SAE 5W-30 Longlife motor oil	5

LABEL INSTRUCTIONS

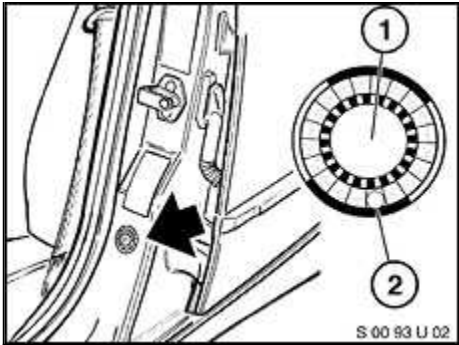
	<p>This Service Action has been assigned code number 61. After the vehicle has been checked and/or corrected, obtain a label (MD20-064) and:</p> <ol style="list-style-type: none"> Emboss your MINI dealer warranty number in the middle of the label (1); Punch out code number 61 (2), printed on the label; and Affix the label to the B-pillar as shown.
--	--

If the vehicle already has a label from a previous Campaign, affix the new label next to the old one. Do not affix one label on top of another one, because a number from an underlying label could appear in the punched-out hole of the new label.

WARRANTY INFORMATION

The repair described in this bulletin is covered under warranty regardless of time or mileage.

Reimbursement for this Service Action will be via normal claim entry utilizing the following information.

--	--	--

Defect Code:	00 11 08 03 00	
Main Work		
Labor Operation:	Labor Allowance:	Description:
00 61 055	Refer to KSD2	Checking chain tensioner
or		
00 61 056	Refer to KSD2	Checking chain tensioner, replacing chain tensioner and checking timing chain
or		
00 61 057	Refer to KSD2	Checking and replacing timing chain tensioner and timing chain
or		
00 61 120	NEW Refer to KSD2	Checking and replacing timing chain tensioner, timing chain and removing and installing/sealing engine oil pan to remove fragments when necessary

The labor operation codes above are Main labor operations. If you are using a Main labor code for another repair, use the appropriate Plus code labor operation below.

Plus Work (Vehicle already in the workshop)

Labor Operation:	Labor Allowance:	Description:
-------------------------	-------------------------	---------------------

00 61 689	Refer to KSD2	Checking chain tensioner
or		
00 61 690	Refer to KSD2	Checking chain tensioner, replacing chain tensioner, and checking timing chain
or		
00 61 691	Refer to KSD2	Checking and replacing timing chain tensioner and timing chain
or		
00 61 855	NEW Refer to KSD2	Checking and replacing timing chain tensioner, timing chain and removing and installing/sealing engine oil pan to remove fragments when necessary

Sublet

Sublet Code 4	See sublet reimbursement calculation below	Reimbursement for repair-related materials (Part numbers not eligible for claim submission)
---------------	--	---

Sublet reimbursement calculation for claiming used quantities of repair-related materials:

- MINI part numbers (including the engine oil and Loctite 5970) at dealer net plus handling; or
- Other materials not available through MINI and obtained locally at cost plus 20 percent.

Enter the material cost in sublet and itemize the amount in the claim comment section.

Other Repair

Please review the vehicle's DCSnet Warranty Vehicle Inquiry and the Key Reader/ISPA Light application's information to determine if the Service Action outlined in SI M11 05 13 (Defect Code 00 11 17 03 00) also applies.

MINI Maintenance Program

For vehicles with an active maintenance program:

When the engine oil and filter are replaced in conjunction with removing and installing the engine oil pan, and the engine oil service is showing "Recommended" or "Due," reset the CBS data and claim as follows:

Defect Code:	85 99 05 01 MP	
Main Work		
Labor Operation:	Labor Allowance:	Description:
00 00 105	Refer to KSD2	Service – standard scope

Claim comment

Engine oil and filter replaced with removal and installation of the oil pan as part of the N14 Engine Check Timing Chain Tensioner and Timing Chain Service Action.

Plus Work

NEW Claim the Plus code labor operation: 00 61 855 for:

Checking and replacing the timing chain tensioner, timing chain and removing and installing/sealing the engine oil pan to remove fragments

when necessary, when this work is performed.

[Copyright ©2014 BMW of North America, Inc.]