

TOYOTA

COROLLA SEDAN

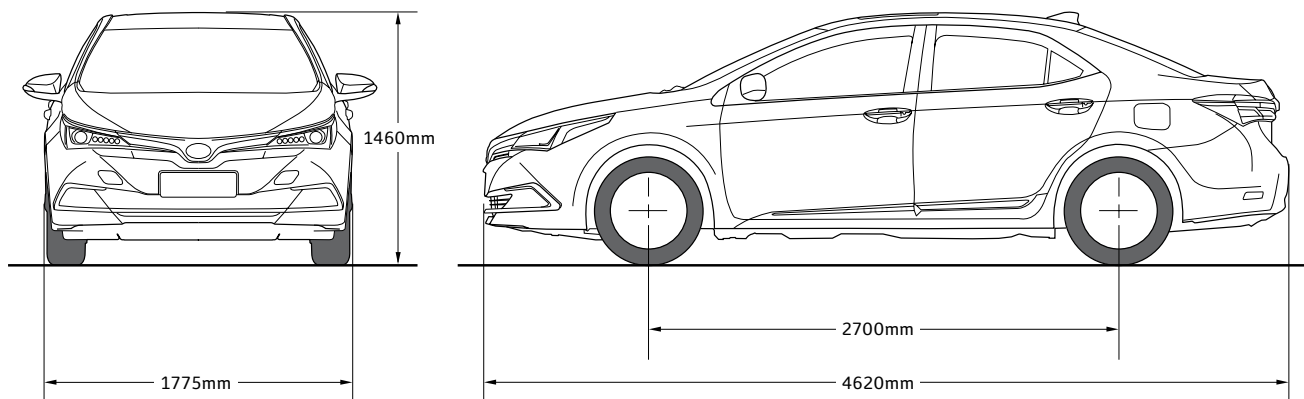

| MECHANICAL SPECIFICATIONS | | Ascent | SX | ZR |
|-------------------------------|---|-------------------------|-------------------------|-------------------------|
| Engine | 1.8L 4-cylinder in-line and 16-valve Double Overhead Camshafts (DOHC) with Dual VVT-i | • | • | • |
| | Petrol – Max. power: 103kW/6400rpm, Max. torque: 173Nm/4000rpm | • | • | • |
| Fuel | Fuel economy: 1.8L manual | 6.8L/100km ¹ | 6.8L/100km ¹ | |
| | Fuel economy: 1.8L CVT | 6.4L/100km ¹ | 6.4L/100km ¹ | 6.4L/100km ¹ |
| | Recommended fuel octane rating | 91 or more | 91 or more | 91 or more |
| Transmission | 6-speed manual | • | • | |
| | 7-speed CVT | • | • | • |
| Capacities | Seating capacity | 5 | 5 | 5 |
| | Fuel tank capacity (litres) | 55 | 55 | 55 |
| Exterior | Steel wheels | 15" | | |
| | Alloy wheels | Optional 15" | 16" | 16" |
| | Full size spare wheel | • | • | • |
| | Front fog lamps | | • | • |
| | Body coloured and electric door mirrors with side turn lamp | • | • | • |
| | Halogen headlamps with manual levelling | • | • | |
| | Bi-LED headlamps with Daytime Running Lamps (DRLs) | | | • |
| | Automatic headlamp levelling | | | • |
| Automatic rain sensing wipers | | | • | |
| Interior | Front bucket seats | • | • | • |
| | 60/40 split fold rear seats | • | • | • |
| | Power windows (front and rear) | • | • | • |
| | Auto-dimming rear view mirror | | | • |
| | Premium 3-spoke steering wheel | | • | • |
| | Premium shift lever | | • | • |
| | Leather accented interior | | | • |
| | Power adjustable driver's seat and lumbar support | | | • |
| | 4.2" colour Multi Information Display (MID) | • | • | • |
| | Cruise control | • | • | • |
| | Smart Entry and Start system | | • | • |
| | Tilt and telescopic steering column adjustment | • | • | • |

| MECHANICAL SPECIFICATIONS | | Ascent | SX | ZR |
|---|---|----------|----------|----|
| Interior <i>continued</i> | Steering wheel controls for MID, telephone and audio | • | • | • |
| | 7-speed CVT with paddle shift controls | | | • |
| | Manual air conditioning | • | • | |
| | Single-zone automatic climate control air conditioning | | | • |
| Storage and | Front and rear cup holders | • | • | • |
| | Bottle holders – front and rear | • | • | • |
| | Accessory socket (front) | • | • | • |
| | Coin box | • | • | • |
| | Front seat back pockets | • | • | • |
| | Driver and passenger sunvisors with vanity mirrors and lamps | • | • | • |
| | Rear coat hooks (x2) | • | • | • |
| | Headlight reminder warning buzzer | • | • | • |
| | Seatbelt warning light and buzzer – front seats | • | • | • |
| | Centre console with storage box lid | • | • | • |
| Sound system | 7" touchscreen colour display | • | • | • |
| | Toyota Link ² | • | • | • |
| | Voice recognition | • | • | • |
| | Bluetooth ^{®3} hands-free connectivity | • | • | • |
| | USB input for compatible iPods ^{®4} /USB memory sticks | • | • | • |
| | AUX 3.5mm audio input for portable audio players | • | • | • |
| | Six speakers | • | • | • |
| Satellite navigation ⁵ with SUNA [™] traffic channel ⁶ | | • | • | |
| Safety | Emergency Brake Signal | • | • | • |
| | Toyota Safety Sense (Pre-Collision Safety system, Lane Departure Alert, Automatic High Beam) | Optional | Optional | • |
| | Vehicle Stability Control (VSC) and Traction Control (TRC) | • | • | • |
| | Anti-lock Braking System (ABS) with Electronic Brake-force Distribution (EBD) and Brake Assist (BA) | • | • | • |
| | Seven SRS airbags | • | • | • |
| | Three child restraint anchorage points | • | • | • |
| | Reversing camera with fixed guidelines | • | • | • |
| | Front and rear clearance sensors | • | • | • |
| | Rear parking sensors | • | • | • |
| Security | Engine immobiliser | • | • | • |
| | Anti-theft alarm | | | • |

1 Achieved in test conditions. Actual fuel consumption may vary depending on driving conditions/style, vehicle condition and options/accessories fitted. Fuel consumption data provided for comparison purposes only. Source: ADR81/02 combined.

2 Toyota Link is available on certain vehicle models and grades only. Toyota Link services rely on data from the driver's compatible mobile phone and information provided by third parties. Availability is dependent on a number of factors, including the availability of third party information, mobile service, sufficient mobile data allowance and

GPS satellite signal reception. Mobile usage is at the user's cost. Toyota Australia reserves the right to add, remove or modify applications. Compatibility with smartphones will vary according to model and operating system. Further information (including smartphone compatibility) is provided at www.toyota.com.au/toyotalink

3 The Bluetooth[®] word mark is owned by Bluetooth SIG, Inc. Not all devices are compatible and functionality varies depending on the device.

4 iPod[®] is a trademark of Apple, Inc. Not all devices will be compatible and functionality will vary depending on the device.

5 Current navigation mapping database encompasses major capital and primary national road networks and offers some coverage in regional areas.

6 SUNA[™] GPS Traffic Updates are only available in metropolitan Adelaide, Brisbane, Canberra, Gold Coast, Melbourne, Perth and Sydney; it operates from information provided by Intelematics Australia and may not cover all road incidents and congestion. See sunatrafic.com.au for details.

IMPORTANT NOTICE – PLEASE READ: Toyota Australia uses its best endeavours to ensure material is correct when published. Check with your authorised Toyota dealer when ordering to ensure the vehicle with your chosen specifications, equipment and colour is available and can be delivered within the timeframe suitable to you. When ordering accessories, check with your authorised Toyota dealer to ensure the accessory's design, features and colours are available and fit your vehicle. Ensure the mass of your load does not exceed the maximum allowable individual axle capacity, Gross Vehicle Mass and/or

Gross Combined Mass of the vehicle. Refer to toyota.com.au for further details. Colours displayed are a guide only and may vary from actual colours due to printing/display processes. Certain accessories when fitted will require the removal of standard equipment, which may be retained by Toyota Australia or your Toyota dealer. Toyota Australia reserves the right to change, without notice, prices, colours, materials, equipment, specifications and discontinue colours/models. To the extent permitted by law, Toyota Australia will not be liable for any damage, loss or expense incurred as a result of reliance on this

material in any way. Distributed nationally (other than in Western Australia) by Toyota Motor Corporation Australia Limited ABN 64 009 686 097, 155 Bertie St, Port Melbourne 3207. Material distributed in Western Australia by or on behalf of Prestige Motors Pty Ltd (for vehicles) and by Eastpoint Pty Ltd (for parts/accessories). Toyota Australia makes no warranties regarding (and will not be liable for) accuracy of materials distributed in Western Australia. PROOF HQ: T2017-006422. FEBRUARY 2017. GTP1708.