

Technical Journal			
TITLE: Clunking/pulling, Bushing in rear stay broken			
REF NO: TJ 25336	ISSUING DEPARTMENT: Technical Service	CAR MARKET: United States	
PARTNER: 3 US 7510 Volvo Cars North America		ISSUE DATE:	
FUNC GROUP: 6522	FUNC DESC: Cross stay	YEAR 2012	MONTH 11
		DAY 28	
Page 1 of 17			

“Fixed Right — First Time”

Attachment

File Name	File Size
TJ Instruction-370831-2_1_1_en-US[1].pdf	0.9830 MB
TJ 25336 -1.jpg	0.0547 MB
TJ 25336 -3.jpg	0.2355 MB
TJ 25336 -4.jpg	0.0809 MB
TJ 25336 -5.jpg	0.0663 MB
TJ 25336 -2.jpg	0.4504 MB

Vehicle Type

Type	Eng	Eng Desc	Sales	Body	Gear	Steer	Model Year	Plant	Chassis range	Struc Week Range
124							2007-9999		0000001-9999999	200606-999999
134							2011-9999		0000001-9999999	201020-999999
135							2008-9999		0000001-9999999	200720-999999
136							2008-9999		0000001-9999999	200720-999999
156							2009-9999		0000001-9999999	200835-999999

CSC Customer Symptom Codes

Code	Description
QF	Steering/Constant pull to left
QG	Steering/Constant pull to right
QH	Steering/Other steering/handling problems
E7	Suspension/Unusual noise
WZ	Suspension/Clicking/clonking noise



DTC Diagnostic Trouble Codes

Text

DESCRIPTION:

The front bushing in the rear longitudinal stay may fail, causing one or more symptoms:

- Knocking / clunking noise from rear suspension on uneven roads.
- Pulling / drifting due to incorrect wheel alignment / rear wheel camber angle.
- Unstable rear suspension on curvy roads.

The analysis indicates that there could be some corrosion on the bushing's outer metal ring, which causes the vulcanized rubber to loosen.

PRODUCT MODIFICATION:

Waxed bushings, which may reduce corrosion, were introduced in production from 2012w10.

Approx. chassis breakpoints:

124-161000

135-242000

136-140000

134-134000

156-324000

SERVICE:

Replace the bushing according to the attached TJ Instruction.

After installing the new bushing, spray rust proofing wax on the bushing outer metal ring to prevent repeat repair (picture #3).

Parts:

Note: Parts will be listed in Parts Catalogue from VIDA 2012DU2.

Bushing, left side with standard attachment (see picture #4): PN 31387280

Bushing, left side with large attachment (see picture #5): PN 31387282

Bushing, right side: PN 31387281

Rust proofing wax: PN 9510226 (500ml/18fl.oz). Use 25ml/0.85fl.oz on each side (50ml/1.8fl.oz total).

Note: Never use other rust preventers! Solvent based chemicals will damage the rubber bushing!

MATERIAL RETURN:

None.

**VEHICLE REPORT:**

Only required for vehicles produced after the chassis breakpoints listed above. Create a Technical Helpdesk Vehicle Report using Function Group 6522.

VSTG OPERATION NUMBER:

65271-2 Rear longitudinal stay 1 side replace	See VSTG
65272-2 Rear longitudinal stay 2 sides replace	See VSTG
99400-2 General check/adjust acc to Technical Journal	0.1 hours

To view TJ attachments continue to next page: This TJ has six attachments.



Volvo Car Customer Service

TJ Instruction VCC-370831-2

Title	Bushing front lateral link	Page	1(9)
Action	Replacement	Operation number:	65214-2 65215-2

Issue	Date	Reason
1	2012-08	First issue

Affected vehicles

Year	Model
2011, 2012, 2013	S60 (11-)
2007, 2008, 2009, 2010, 2011, 2012, 2013	S80 (07-)
2008, 2009, 2010, 2011, 2012, 2013	S80L
2011, 2012, 2013	V60
2008, 2009, 2010, 2011, 2012, 2013	V70 (08-)
2009, 2010, 2011, 2012, 2013	XC60
2008, 2009, 2010, 2011, 2012, 2013	XC70 (08-)

Special tools

Description	Part No.
Ring	999 7469
Drift	999 7467
Hydraulic hole cylinder	951 2923
OK	999 7468

Equipment

Designation	Part No.
Hydraulic press	

Removal

Note! Removal steps in this procedure may contain installation details.

Follow instructions for lifting points body frame, refer to:

Specifications, mechanical

8 - Body and interior

81 - Body frame

810 - general

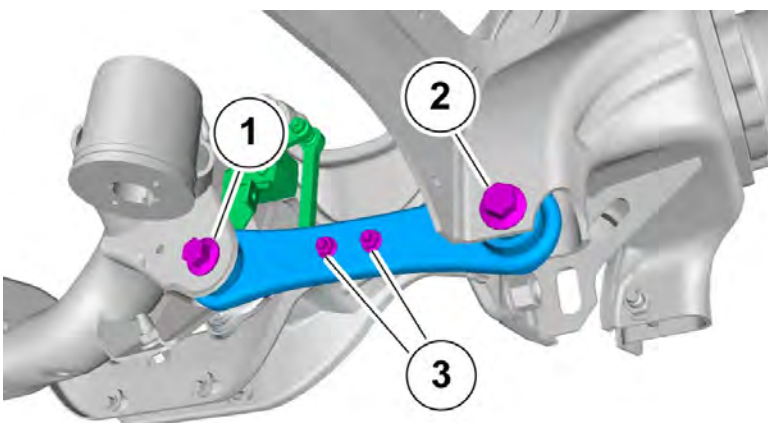
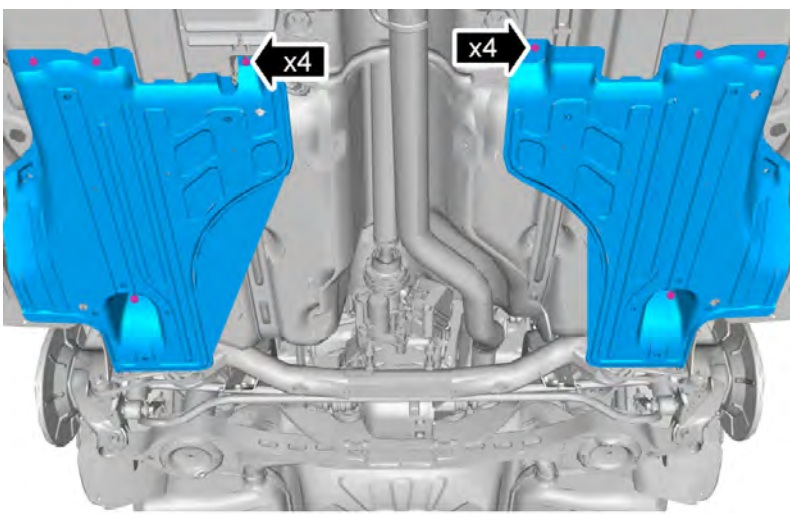

Remove the following components:

1. **Torque:**
Tie rod to subframe, 110 Nm
2. **Torque:**
Tie rod to longitudinal stay, 110 Nm
3. **Torque:**
M6, 10 Nm

Vehicles with load-leveling shock absorbers

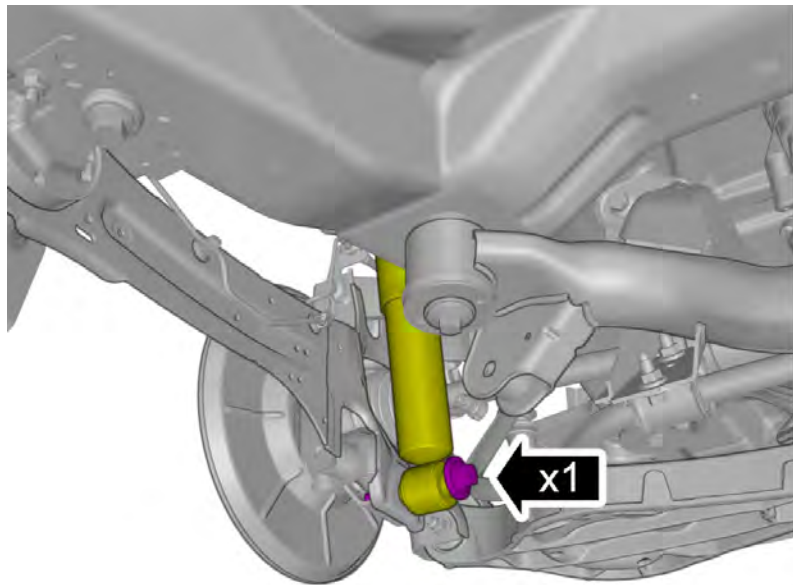
**Torque:**

Rear shock absorber to wheel knuckle
(Nivomat), 280 Nm

Vehicles without load-leveling shock absorbers

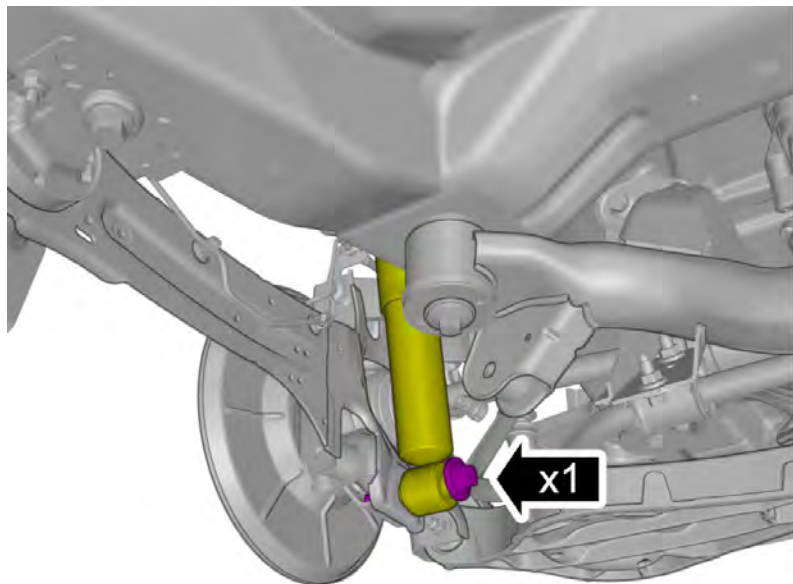
**Torque:**

Rear shock absorber to wheel knuckle,
175 Nm

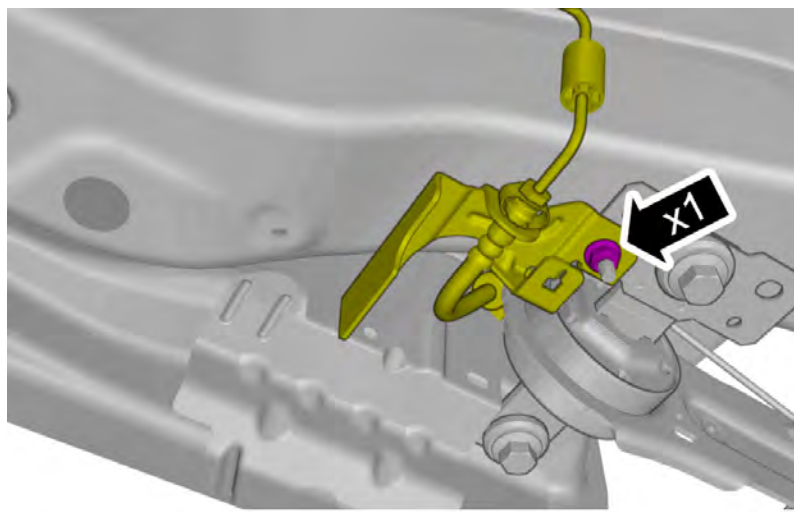

Torque:
M8, 24 Nm

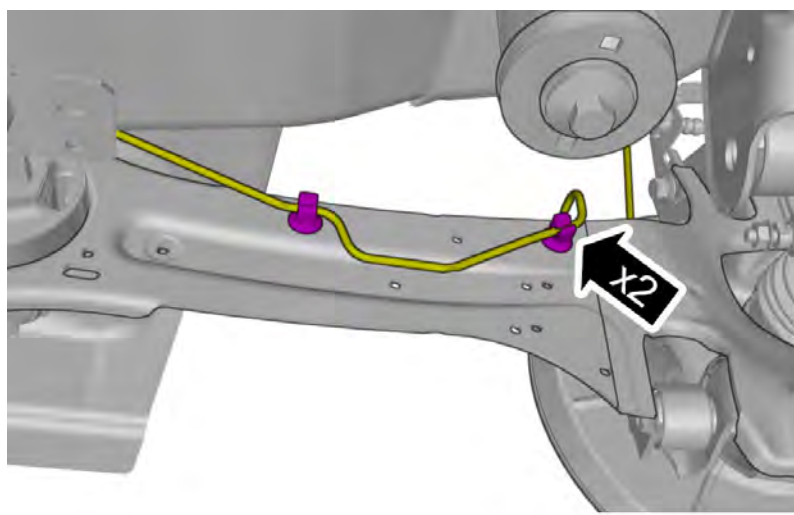

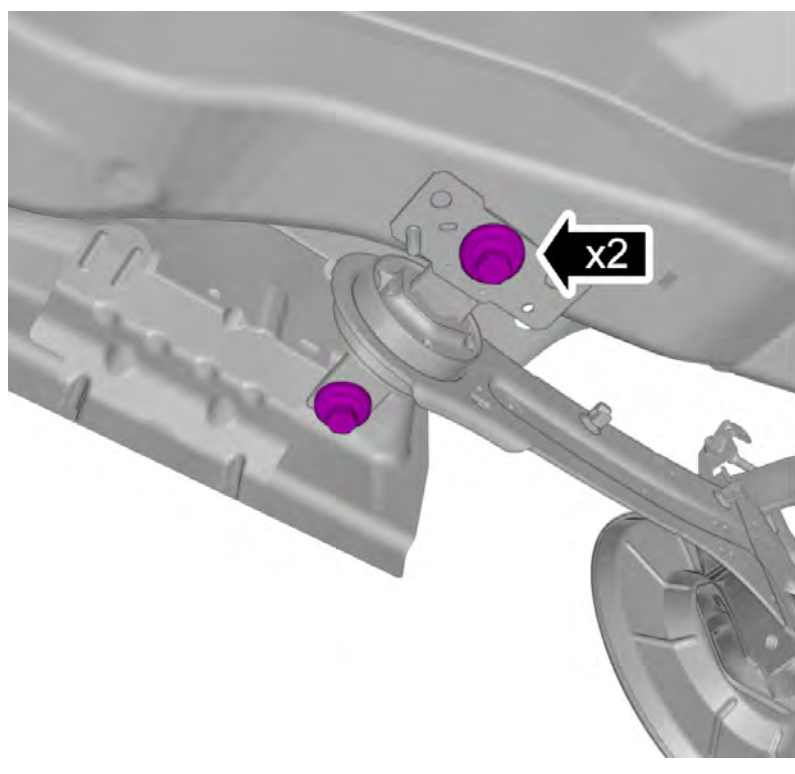

Torque:

Wheel knuckle rear to body, 180 Nm

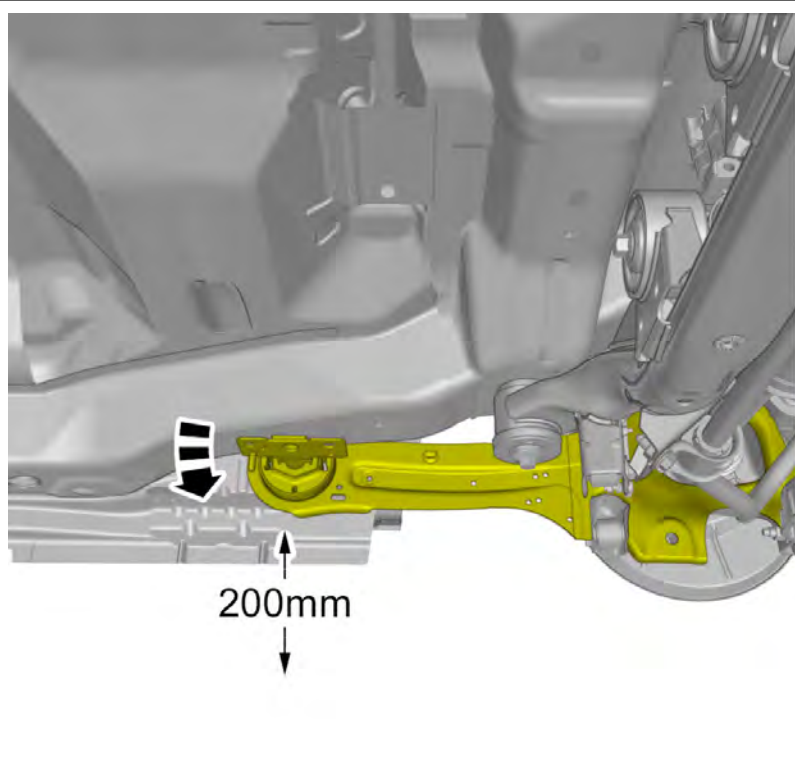

Caution! Make sure that the component is positioned correctly.

Special Tool: T9997469, Ring

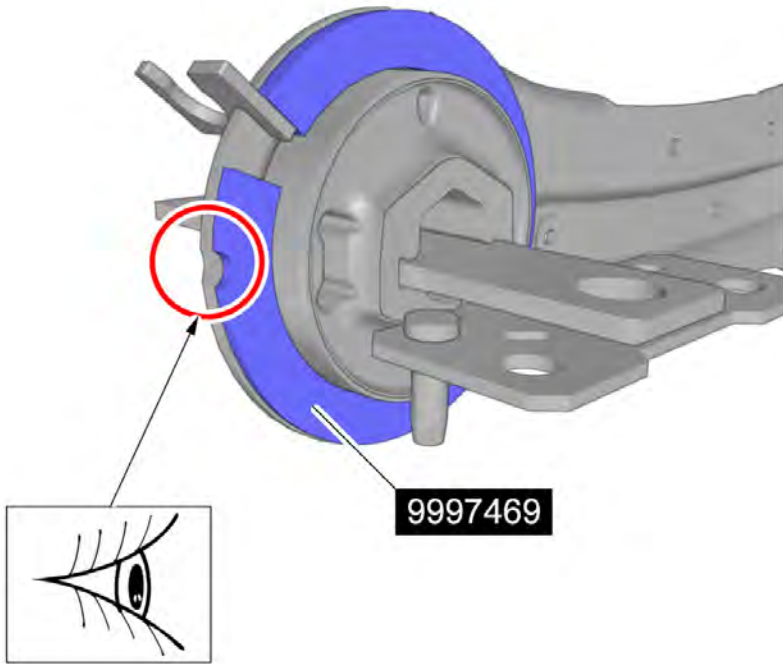

Special Tool: T9997467, Drift

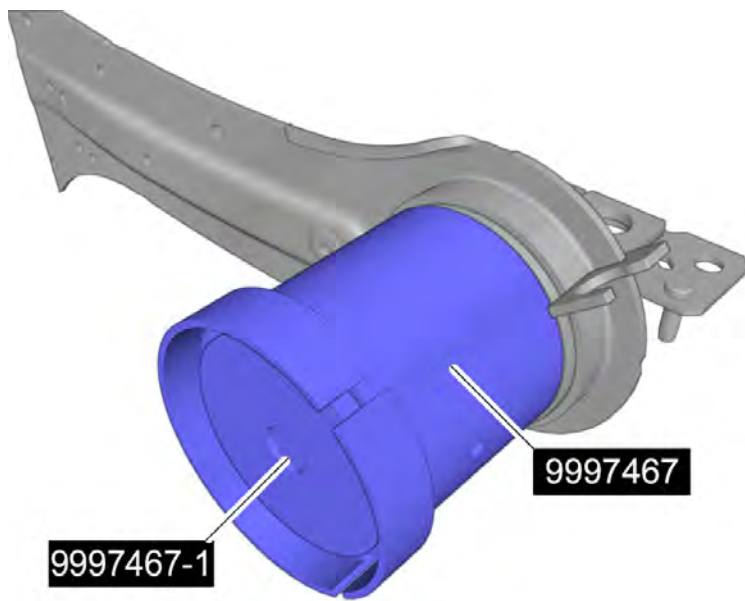

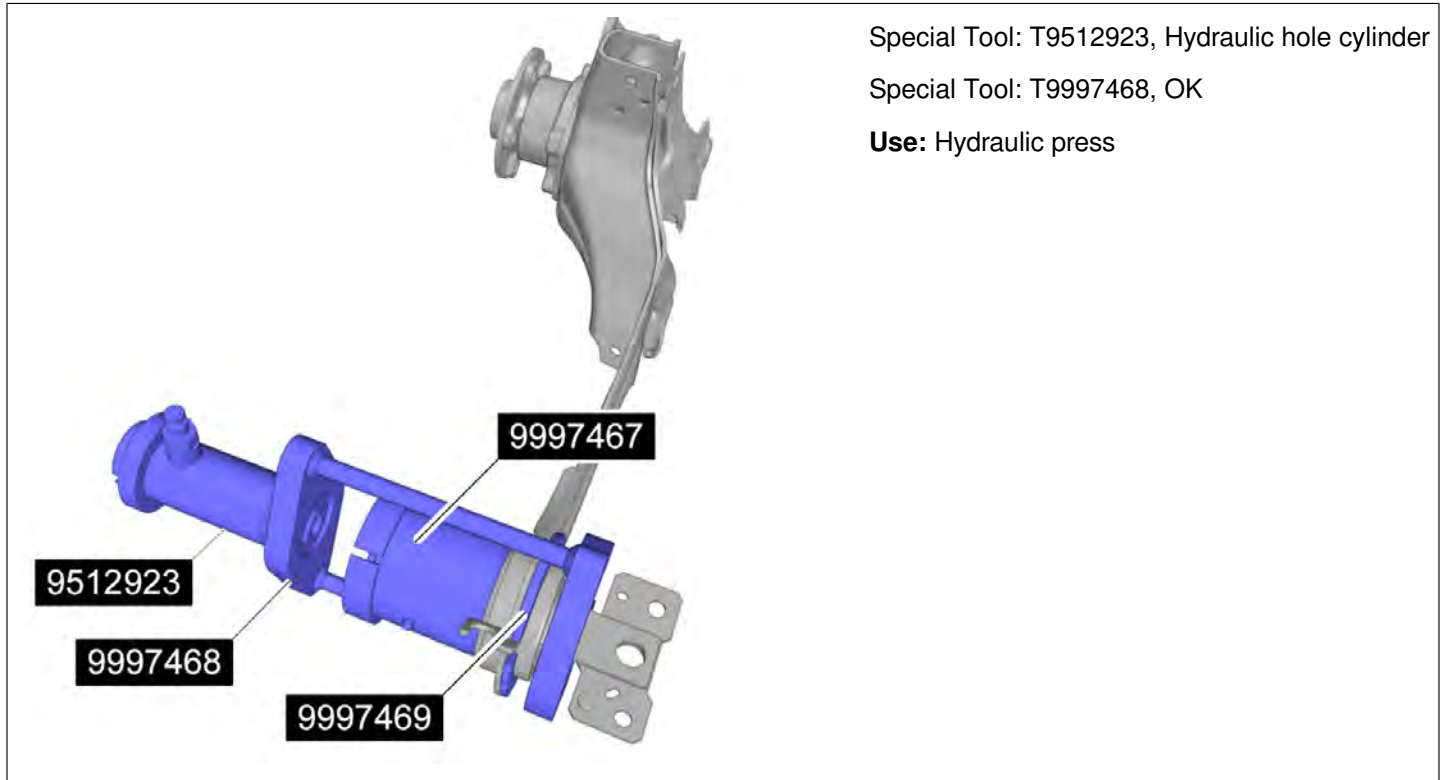

Installation

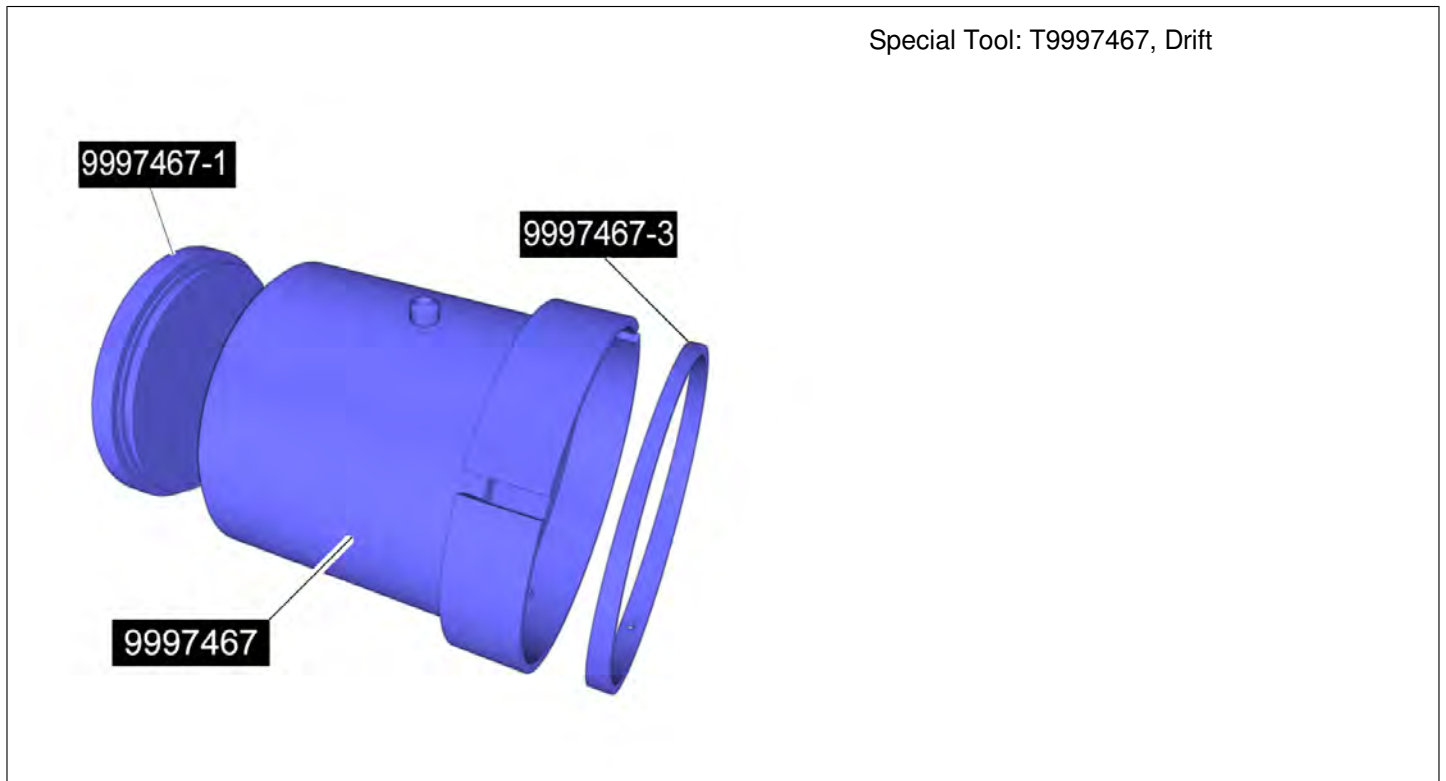

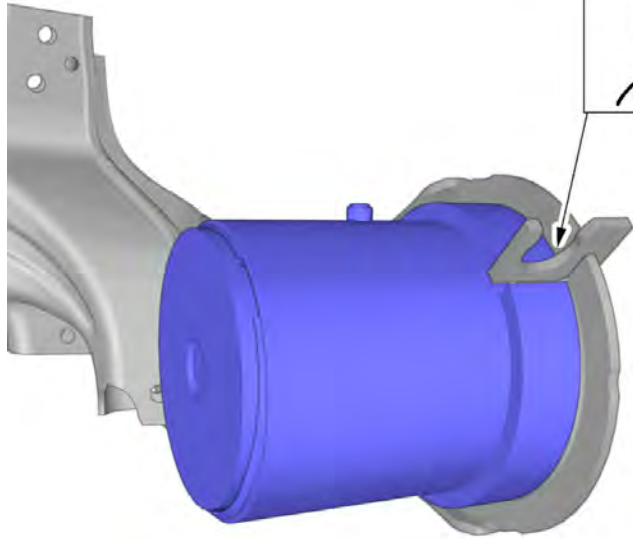

Caution! Make sure that the component is positioned correctly.

9997467

9997470

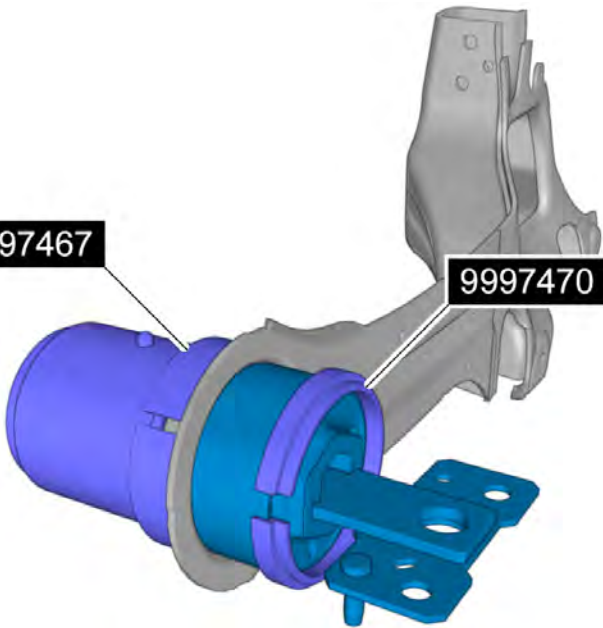

Use: Hydraulic press

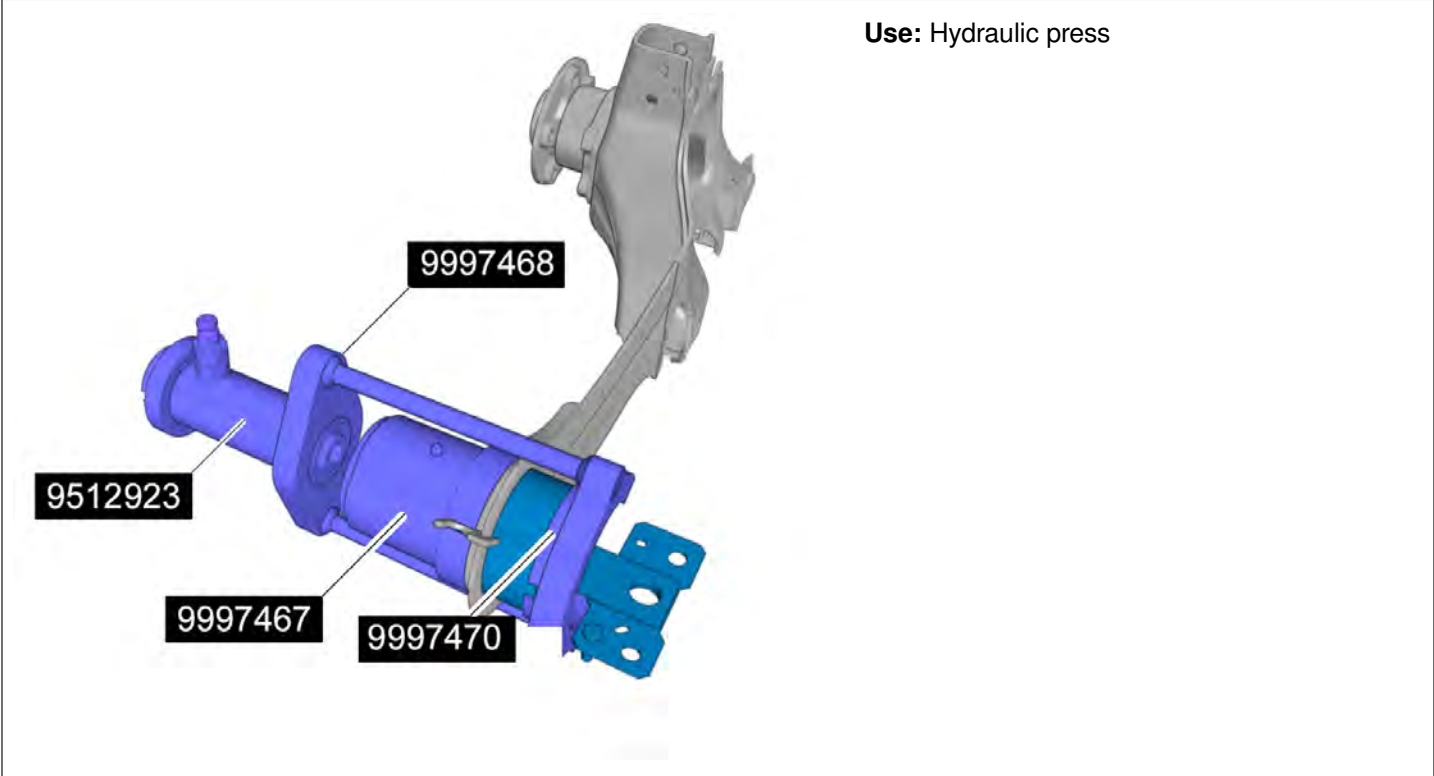

To install, reverse the removal procedure.

TJ 25336

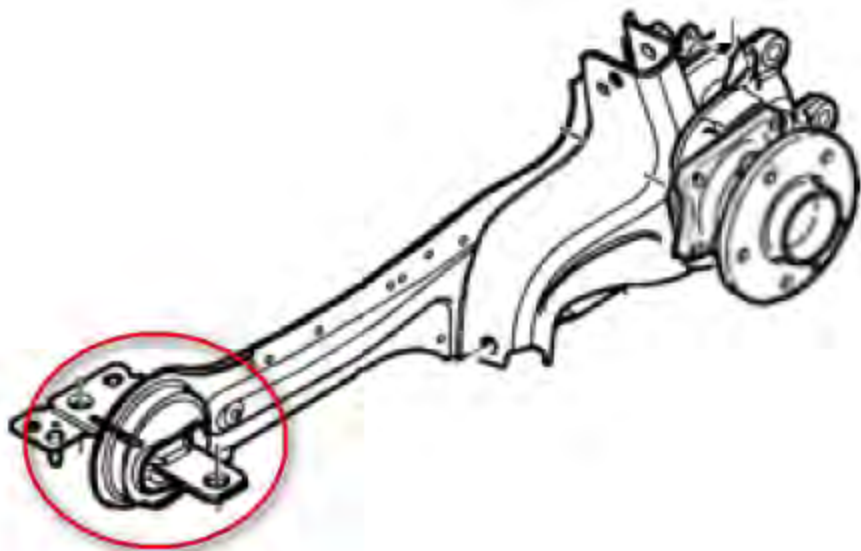

TJ 25336



TJ 25336

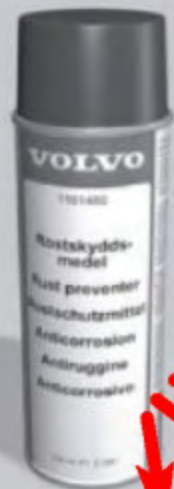

TJ 25336

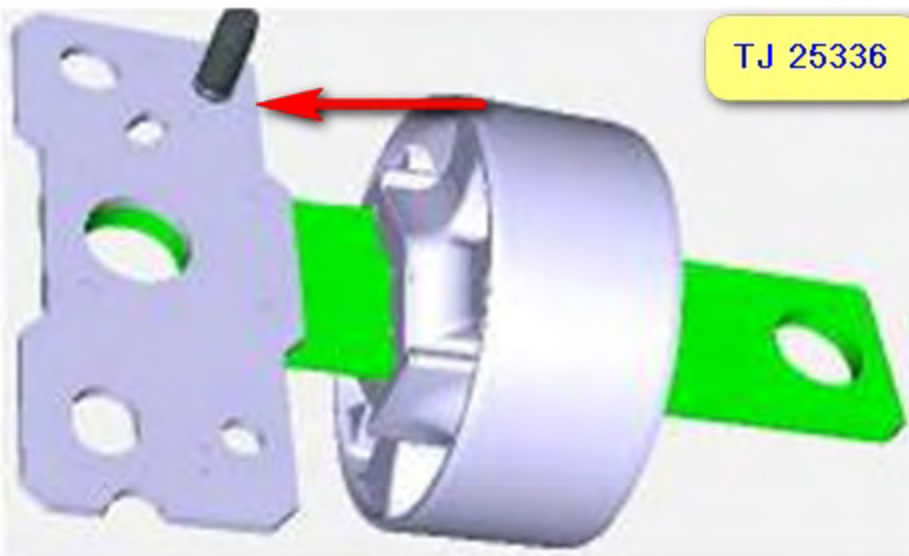

TJ 25336

