



THE ALL-NEW
VOLVO V60
CROSS COUNTRY



WE'RE VOLVO CARS.

We put people first.

We're Swedish. Scandinavian designers always start with the person who's going to use an object and ask, "What can we do to make this person's life better, easier or more comfortable?"

We've always used this philosophy when we design our cars. So, while other car manufacturers might start with technology and try to squeeze people in around it, we begin by designing our cars around you. We ask what you need, and then use our technical skills to make your life easier, better, safer and more beautiful. Form follows function, and when you design a car inside and out with people in mind, it looks naturally beautiful. We think that looking at and interacting with our cars should make you feel great, every day.

Designing cars around people has led to many innovations over our 89-year history. You know the three-point safety belt in your current car? That was our invention from 1959. And now we're working towards our vision to design cars that should not crash. In the shorter perspective, our aim is that by 2020 nobody should be killed or seriously injured in a new Volvo. Of course, you'll already benefit from this research in your current Volvo. We've addressed a few environmental issues, too. In 1976 we developed the Lambda Sond – a sensor that monitors exhaust gas, reducing emissions and boosting performance as well as economy. It's still part of every petrol-engined car in the world. Innovation is at the core of Volvo Cars – it's because of where we come from.

Contents

YOUR NEW CAR | 02

INSIDE YOUR CAR | 08

YOUR ADVENTURE | 10

SENSUS | 12

INTELLISAFE | 16

ENGINE | 20

COLOURS | 26

WHEELS | 28

PERSONALISE
YOUR INTERIOR | 30

UPHOLSTERIES | 32

ACCESSORIES | 34

FACTS AND FIGURES | 38

THE VOLVO
EXPERIENCE | 40





The minute you set eyes on the Volvo V60 Cross Country, you know it means business. The V-shaped bonnet, strong shoulders and falling roofline speak of pace and athleticism. At the same time, rugged design cues add to the car's muscular stance and leave you in no doubt that this car is ready for any adventure.

Yes, this Cross Country sportswagon is a dynamic driver's car, but it also allows you to take everything you need on your weekend away, no matter how remote your destination is. And thanks to the protective design elements of the Volvo V60 Cross Country, it's much less vulnerable to scratches and minor damage.

At the heart of the Volvo V60 Cross Country's dynamic and capable driving experience is a great chassis. We've spent thousands of hours perfecting and tuning it, and heightened its responsive, in-command driving experience. Then, we added All-Wheel Drive and gave our sportswagon 201mm ground clearance for real all-road, all-weather capability.

When you get behind the wheel, you'll discover another great example of outstanding Swedish people-focused design. Seats have been a strength of Volvo Cars since the 1970s, when we enlisted ergonomic experts to help us develop a supportive shape that ensures you arrive fresh and relaxed after even the longest journey. With the Volvo V60 Cross Country, we've been able to give you the same comfort in the shape of a sport seat, as befits a true driver's car.

Then, there's the sheer build quality. You can always tell true craftsmanship by looking at the details. The Volvo V60 Cross Country has beautifully styled integrated tailpipes, which are the physical and visual link to our technically advanced, highly efficient new generation of drivetrains.

So if you're looking for a car that not only stands out from the crowd, but is also a perfect companion for you and your family on all roads, the Volvo V60 Cross Country is for you.





*"It's ideal if you have an adventurous lifestyle,
taking you where you want to be, whatever the weather."*

VOLVO V60 CROSS COUNTRY

*Adventure that lives up
to its promise.*

If you're the sort of person who goes out and explores the world, the Volvo V60 Cross Country is the car for you: a sportswagon that not only offers dynamism and versatility, but rugged looks and all-road capability, too. It's ideal if you have an adventurous lifestyle, taking you where you want to be, whatever the weather. And thanks to its loadspace and versatility, you can follow the call of the wild with your children in tow.

Even when it's parked in the driveway, the Volvo V60 Cross Country exudes a sense of

adventure. Its sweeping roof and tapered rear windows give a sense of urgency, while its tall, in-command posture and muscular design cues signal a readiness to take on the world. It's the sort of car you spot from a distance – an individualist's choice that stands out from the crowd. After all, your life is out of the ordinary, so why hide in an ordinary car?

The sense of being in control continues on the inside. The minute you sit down in our seats, you feel in complete control, no matter

what the road or the weather throws at you. Once you set off on your journey, the high ground clearance gives you a great overview in town – as well as the capability to leave the city far behind. And when the road gets rough or the weather turns ugly, the All-Wheel Drive Volvo V60 Cross Country comes into its own, and will see you safely to your final destination. No matter where you go, no matter what the season, our Cross Country sportswagon lives up to its promise.





The Volvo V60 Cross Country is a car you spot from a distance. Its high ground clearance helps you to feel in control around town, as well as providing the ability to take on rougher roads. It also communicates pride and confidence – and the car's silver roof rails accentuate this stature further.

Take a closer look and you'll find that glossy black detailing on the mirrors and window frames adds another touch of

exclusivity. But the Volvo V60 Cross Country is, above all, a capable, athletic car.

With rugged design elements all around, this car challenges you to take it on an adventure, braving the elements and exploring new terrain. In the front, a black honeycomb grille and lower grille moustache in black give it our unique Cross Country "face", which is further enhanced by a front skid plate.

Black wheel-arch extensions make for a wide, muscular stance and continue seamlessly into the distinctive side scuff plates. There's also a rear skid plate, which protects your car from gravel when you leave the tarmac. And the famous Cross Country logotype lets the world know that you're ready for action.





No need to take your hands off your steering wheel as you shift up and down the automatic gearbox in manual mode – just flick through the gears with our gearshift paddles. You'll be in total command of your car, with both hands on the wheel. And quicker gear changes give your drive an additional edge when you're in the mood for upping the tempo.



*“We’re famous for our seats
– they’re a proud tradition for us at Volvo Cars.”*



We’ve designed the cockpit around you, the driver. Get inside and feel in complete command as the dashboard gently angles towards you. We were inspired by high-performance motorbikes when we came up with the idea of a single round instrument flanked by two smaller dials. Then, we carefully sculpted the three-spoke steering wheel with the aim of giving you a very physical sense of connection between your car and the road. But where you sit is even more important. “We’re famous for our

seats,” says V60 Cross Country Product Manager Stefan Sällqvist. “They’re another proud tradition for us at Volvo Cars. Our sport seats look fantastic and, true to our unrelenting commitment to ergonomic design, you’ll be able to drive for hours sitting in it without getting tired. It also has great side support all the way from your thighs to your shoulders, so the seats keep you firmly in position even when you’re cornering fast.”



"This is a Volvo for people who don't just talk about adventure, but live it, too."

CHASSIS & CAPABILITY

Are those rugged looks for real? Oh, yes.

This is a Volvo for those individuals who live life as a genuine adventure. And the V60 Cross Country doesn't just look the part, it's got the capability to back up that seriously rugged profile. For example, the Cross Country features 201mm of ground clearance, which is a significant 65mm higher than that of our standard V60 – a crucial factor in any vehicle's ability to take on rough terrain or deep snow and mud.

And with All-Wheel Drive, you'll have even more capability to carry on when conditions turn difficult. After all, adventure

often takes you to unexplored roads. And when you find yourself facing a particularly challenging hill, the Hill Descent Control helps ensure a safe, smooth and "in-control" ride down – all you need to do is steer.

But this is still a true Volvo, with as much ability on road as off with a suspension that delivers a fine combination of ride and handling. Enthusiastic drivers will also appreciate the Corner Traction Control with Torque Vectoring – a technology that enables the Volvo V60 Cross Country to turn into corners with sporting precision, and

effectively resist understeer (the tendency of the front wheels to push wide in corners).

So this really is a Volvo for people who don't just talk about adventure, but live it, too. For them, all-weather capability and the ability to occasionally leave smooth, well-travelled roads behind is essential. For that, you need a tough, durable partner. And that's really what the Volvo V60 Cross Country is all about – not just its rugged good looks, although that's a nice bonus.



“Sensus is about making your interaction with your car intuitive, and ensuring you’re on the road, but not offline.”

SENSUS

The intuitive way to interact with your car.

Volvo Sensus is our all-encompassing approach that connects you with your car and the world around you. It means you're on the road, but not offline. With Sensus Connect, you can turn the 7-inch screen in your dashboard into an internet-connected infotainment hub. Not only can you surf the web, you can also download various apps.

Sensus Connect also gives you access to basic internet maps and routing, and to take advantage of navigation guidance, 3-D views and navigation apps, there's our Sensus Navigation option.

Connected Service Booking allows you to book your car in for a service from the comfort of the driver's seat.

A high-end audio experience is also part of Sensus. That's why we've designed our state-of-the-art Premium Sound with Harman Kardon®. Using 12 high-fidelity loudspeakers, the amplifier is equipped with Dirac Live®, the next-generation sound enhancement software. With an incredibly realistic stage sound as well as enhanced bass performance, this sound system provides an unparalleled aural experience for every passenger and connects easily with external media players.

Our digital driver display is another delight. Not only does it give you all the information you need without overwhelming you, its three background

modes – Elegance, Eco, and Performance – also sync with the centre screen. The physical controls, such as our floating centre stack with its iconic 'manikin' climate control buttons, are another example of Swedish design that's both functional and beautiful.

And then there's our eye-catching illuminated gearshifter. Glowing gently in the dark, it adds a touch of atmosphere to your night drives.



SENSUS



*“Our vision is to design cars
that should not crash.”*

INTELLISAFE

Intuitive safety by Volvo Cars. For you, and for those around you.

At Volvo Cars, safety is an intrinsic part of our DNA. We've invented some of the world's most pioneering life-saving technologies – such as the three-point safety belt that's been acknowledged as one of the most important innovations of mankind.

But we aim higher. Our vision is to design cars that should not crash. In the shorter perspective the aim is that by 2020 nobody should be killed or seriously injured in a new Volvo.

IntelliSafe is our approach for a more harmonious relationship between cars and people. To achieve this, we have infused your Volvo with smart, intuitive innovations for a safer drive. And the IntelliSafe technologies help protect not only the people inside your car – we also consider people on the outside, for example with technology that helps you to detect pedestrians and cyclists.

When you drive at speeds up to 50km/h, our City Safety collision avoidance technology looks ahead of you and brakes automatically

if you're about to run into a vehicle in front.

To give you more support at higher speeds, our Collision Warning with Auto Brake and Pedestrian and Cyclist Detection alerts you if you're too close to a vehicle and a collision is imminent – day or night. During daylight, the system also reacts if there's a pedestrian in your path or a cyclist ahead travelling in the same direction as your car. And should you not react to the warning, your car brakes automatically to help you avoid or mitigate a collision.

If your car should begin to drift between the lanes, our Lane Departure Warning will alert you to stay in the lane. There's even Driver Alert technology that reminds you to take a break in case your driving behaviour shows signs of drowsiness.

Our IntelliSafe technologies also support your daily driving. The Road Sign Information technology keeps you updated on actual speed limits and other important road signs. At night, our Active High Beam stays on high

beam all the time to optimise your vision without dazzling other road users. And to make you a bit more relaxed on the road, our Adaptive Cruise Control can maintain your set speed and distance to the vehicle in front. In slow-moving city traffic, our Queue Assist function can automatically maintain the selected distance to the car in front – from standstill and up to 30km/h. Our BLIS system helps you to early detect other vehicles in your blind spot, while the Cross Traffic Alert function facilitates reversing out of tight parking spaces where your vision can be restricted.

And because we know you love to drive, our active IntelliSafe technologies like Electronic Stability Control add to reassuring driving stability in all conditions without sacrificing the joy of driving. It's simply about giving you the most human driving experience, on your terms. And helping to keep people out of harm's way, whether they happen to be inside or outside your car.



Light up the dark. Driving in the dark just became a lot more enjoyable and safer. Our Active High Beam stays on high beam all the time. You don't have to flick between low and high beam, and when you meet or catch up another vehicle the system shades out only as much of your beam as necessary to avoid dazzling – while you still get the benefit of a brightly lit road. This intelligent technology can even recognise pedestrians and cyclists and avoid dazzling them, too. And when you enter a city, the high beam shuts off.

FIND OUT MORE AT VOLVOCARS.COM.AU



In town, City Safety is designed to prevent you from colliding with the car in front if it stops, or slows suddenly. This advanced IntelliSafe system will brake automatically to avoid a crash and works at speeds of up to 50km/h. An accident can be avoided at a speed difference of up to 15km/h to the vehicle in front.

Because we also care about other road users, our Pedestrian and Cyclist Detection with Full Auto Brake watches out for people walking in your path or cycling in the same direction as your car – and applies the brakes if you're unable to react in time.

Our BLIS system uses radar sensor technology to alert you to vehicles that are close to or in your blind spots in your adjacent lane. This way, you're far less likely to change lanes when it isn't safe.

When you're reversing out of tight parking spaces, our Cross Traffic Alert function watches out for vehicles you can't see.

READ MORE AT VOLVOCARS.COM.AU



INTELLISAFE





“We’ve mated the twin-turbocharged diesel powerplant to our Geartronic® six-speed automatic, which ensures you get optimum performance at any engine speed.”

Enjoying more. Using less.

We're committed to creating smarter, more innovative technologies to reduce our cars' impact on the environment, we'll never lose sight of the pleasure to be had in driving. In short, we believe you don't need to sacrifice power and superb driveability for efficiency and low CO₂ emissions.

With a highly efficient 2.4-litre five-cylinder D4 diesel engine, we've mated this

twin-turbocharged powerplant to our Geartronic® six-speed automatic gearbox, which ensures you get optimum performance at any engine speed.

Of course, we're committed to a clean environment inside your car as well. As part of CleanZone, all materials in your Volvo's interior are hypo-allergenic and do not emit harmful gases. CleanZone also includes a

highly effective dust and pollen filter. You can boost this further with our Interior Air Quality System. This uses an active carbon filter to reduce harmful gases and particles, enabling you and your passengers to breathe easy – even in polluted cities.





The Volvo V60 Cross Country is available with a 2.4-litre five-cylinder turbo diesel engine designed to offer maximum driving pleasure while using fuel efficiently and keeping CO₂ emissions at a minimum.

In the D4 Luxury, it produces 140kW and 420Nm with All-Wheel Drive as standard. It helps the V60 Cross Country to accelerate from standstill to 100km/h in 8.9 seconds, with fuel economy and CO₂ emissions rated at 5.8l/100km and 153g/km, respectively. The engine is mated to a six-speed Geartronic transmission.

READ MORE AT VOLVOCARS.COM.AU





The exterior colour you choose has a dramatic impact on the personality of your Volvo. But no matter which you choose, each one imbues the car with a sense of luxury and presence.

“Our colour palette is very Scandinavian,” says Ebba Maria Thunberg, who is responsible for colours and material. “When you look at

our palette, you’ll find that it contains softer tones that are more connected with nature, with a few bold splashes.” Being Swedish, our designers are inspired by the ocean and the sky, as well as by the shore and the way the light changes throughout the seasons. Every tone speaks of uniqueness, quality and charisma.



614 Ice White



707 Crystal White Pearl



019 Black Stone



717 Onyx Black metallic



712 Rich Java metallic



700 Twilight Bronze metallic



711 Bright Silver metallic



477 Electric Silver metallic



492 Savile Grey metallic



714 Osmium Grey metallic

From expressive to discreet, elegant to sporty, you can give your Volvo V60 Cross Country a unique twist by the wheels you choose.

Would you like to make an entrance or do you prefer the charm of the understated? Are you going for a sporty persona or an intricate, refined look? Try different wheels on our online configurator and find the one that's right for you.

Neso, 7.5x18"
Diamond Cut/Tech Matte Black





Pan, 7,5x18"
Silver



Bor, 8x19"
Diamond Cut/Matte Black



Pangaea, 7x16"
Silver Stone



Valder, 7,5x17"
Silver

Your Volvo V60 Cross Country
is your home away from home.
Give it your signature.



Choose a Volvo V60 Cross Country and you'll enjoy an elegantly designed cabin as standard, with a superior finish in evidence everywhere you look – from the silk metal finish on our air vents to the fine cloth surfaces on the door pillars.

Our Comfort seats are upholstered in leather as standard, while our Sport seats in leather give you legendary Volvo comfort

while also keeping you firmly in place in those fast corners.

And for added control, our gearshift paddles allow you to change gears with the flick of a finger whenever you have the automatic gearbox in manual mode – so you never have to take your hands off the steering wheel while driving. It's a great feature for added control.

You can go one better by choosing our heated steering wheel, which lets you gently warm your hands in cold conditions.

And with our heated windscreen, you'll never have to stand outside scraping ice off the glass in the freezing cold. Once you're in the driver's seat, you'll appreciate the easy-to-read adaptive digital driver display.





Sport seat



Comfort seat

INLAYS

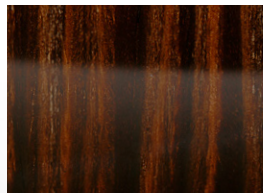

Urbane Wood



Shimmer Graphite aluminium



Piano Black



Leather

Sport Leather



“With the dog gate, you can open the tailgate without your dog leaping out – which makes life so much easier.”

NO TWO LIVES ARE THE SAME.

Make sure your Volvo matches yours.

The most pleasurable part of buying a new Volvo is putting your personal stamp on it. You can do that by choosing accessories that reflect your own taste and that cater to your particular lifestyle.

For the load compartment in the rear, there's our steel safety grille, which is an alternative to the standard safety net. This gas-sprung steel grille is colour coordinated with your interior and helps to protect you and your passengers from unsecured loads when braking sharply. And when you don't need it, it folds conveniently up against the roof.

Our load compartment divider is another great accessory. Used together with the steel safety grille, this divides the load compartment into two sections – convenient if you want to carry your dog and luggage, or to separate dirty or fragile cargo from other cargo.

Our specially designed roof load carriers fit neatly and securely into your car's prepared mounts. They're easy to install and to combine with additional holders if required. And the roof-mounted bicycle holder is a practical and stable holder for carrying your bike on the roof. It fits most

bikes with round or oval frames up to 70mm in diameter. And you can lock it with the Volvo One Key System.

Finally, to give your pet a place of its own, you can complement the safety grille and load compartment divider with our dog gate. It allows you to open the tailgate without your dog leaping out – which makes life so much easier.



FIND MORE ACCESSORIES AT [VOLVOCARS.COM.AU](https://www.volvocars.com.au)

*“A sophisticated welcome every time
you open the front door.”*



Enter your Volvo V60 Cross Country in style, everyday. Our illuminated instep plates give you a sophisticated welcome every time you open the front door – the Volvo logo embedded in the brushed stainless-steel footstep lights up together with the interior lighting.

And adding our Rear Seat Entertainment system with 8-inch touchscreens and integrated DVD players, your rear seat passengers can watch a film or play games. Wireless headphones ensure a relaxed journey for everyone inside the car.

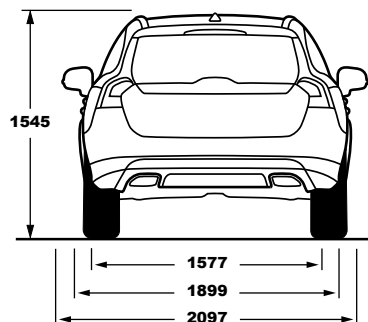
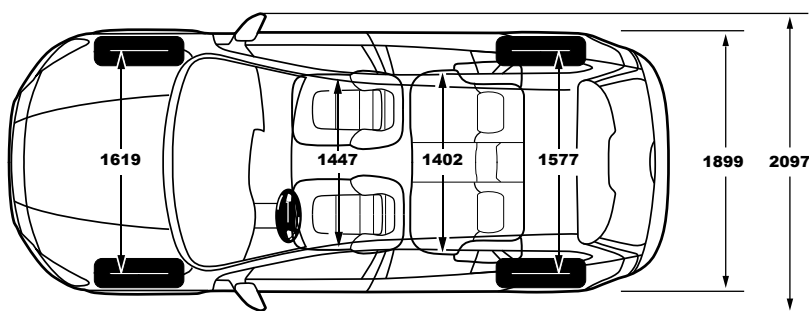
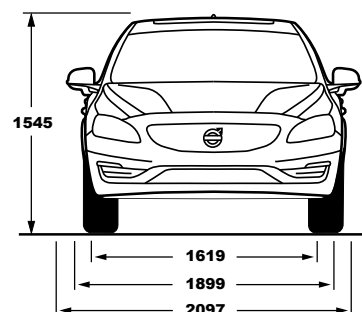
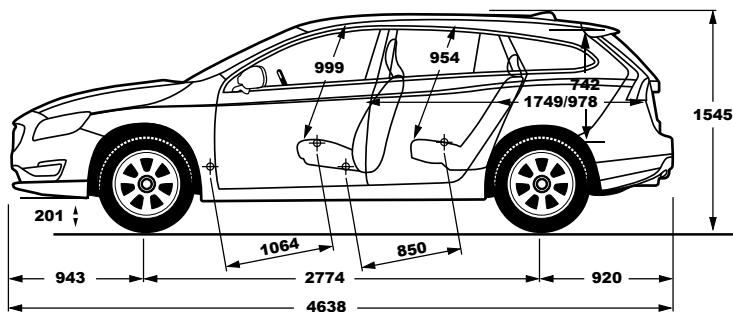

D4 AWD

Engine type:	2.4 l5 common-rail turbodiesel
Transmission:	Six-speed Geartronic®
Fuel consumption, litres/100 km, mixed cycle:	5.8
CO ₂ g/km:	153
Max. power output:	140kW at 4000rpm
Max. torque:	420Nm at 1500-3000rpm
Acceleration, 0-100 km/h in sec:	8.9
Top speed, km/h:	210
Fuel tank, litres:	67.5
Environmental classification:	Euro 6

NB. The engine programme may vary from country to country. All technical data may be subject to change. Please talk to your Volvo Car dealer for the latest information.

Please note: Some of the information in this brochure may be incorrect due to changes in product specifications that may have occurred since printing. Some of the equipment described or shown may now only be available at extra cost. Before ordering, please ask your Volvo Car dealer for the latest information. The manufacturer reserves the right to make changes at any time and without notice to prices, colours, materials, specifications and models.





The simplest way to own a car.

We love it when you're happy – when things are easier than you expect, or go faster and become better. Because when you buy a Volvo, you buy the simplest way to own a car. Financing, insurance, servicing, changing tyres, cleaning – those aspects of car ownership that you might not find very

interesting are the ones that we love to make easier and better for you. That's why your Volvo Car dealer will always offer you a whole range of simplifying services and offers all designed around you, giving you the most carefree ownership experience possible.

Still, this is just the beginning. Through our uniquely Swedish approach to innovation, we continuously find new ways to make your life simpler. For instance, the Connected Service Booking* function, which lets you book an appointment just by pushing a button in your car.

BUYING & OWNING

- Warranties
- Financing
- Insurance
- My Volvo website

MAINTENANCE & SERVICES

- Volvo Service 2.0
- Volvo Professional Car Care
- Software Updates

IF SOMETHING HAPPENS

- Volvo Roadside Assistance
- Repairs
- Volvo Glass Services
- Volvo Dent Repair
- Car Climate Services

MY VOLVO

My Volvo is a personalised website that contains everything you need to really get to know – and get the most out of – your car. It gives you:

- A complete overview of your Volvo Car ownership
- Easy access to all facts relating to your car
- Helpful tips regarding your specific Volvo model
- Instructional films and owner's manuals
- Online Service Booking
- Reminders regarding important stages of your car ownership
- Exclusive articles, films and photographs

CONNECTED SERVICE BOOKING*

If your Volvo has Sensus Connect, it will remind you when it needs servicing and offer to contact your Volvo Car dealer for you. Booking proposals sent from your preferred dealer can easily be managed directly in the car or on your personal My Volvo website. When the time comes to drive to your workshop, your Volvo will remind you and even guide you there. And since your Volvo tells us what it needs, we can make sure it always receives the service it requires when it gets there.

*Available depending on introduction date. Please contact your Volvo Car dealer.

V O L V O