



VOLVO V60



WE'RE VOLVO CARS.

We put people first.

We're Swedish. Scandinavian designers always start with the person who's going to use an object and ask, "What can we do to make this person's life better, easier or more comfortable?"

We've always used this philosophy when we design our cars. So, while other car manufacturers might start with technology and try to squeeze people in around it, we begin by designing our cars around you. We ask what you need, and then use our technical skills to make your life easier, better, safer and more beautiful. Form follows function, and when you design a car inside and out with people in mind, it looks naturally beautiful. We think that looking at and interacting with our cars should make you feel great, every day.

Designing cars around people has led to many innovations over our 89-year history. You know the three-point safety belt in your current car? That was our invention from 1959. And now we're working towards our vision to design cars that should not crash. In the shorter perspective, our aim is that by 2020 nobody should be killed or seriously injured in a new Volvo. Of course, you'll already benefit from this research in your current Volvo. We've addressed a few environmental issues, too. In 1976 we developed the Lambda Sond – a sensor that monitors exhaust gas, reducing emissions and boosting performance as well as economy. It's still part of every petrol-engined car in the world. Innovation is at the core of Volvo Cars – it's because of where we come from.

Contents

YOUR NEW CAR | 02

INSIDE YOUR CAR | 08

OUR DESIGN VISION | 10

SENSUS | 12

INTELLISAFE | 16

DRIVE-E | 20

EXPRESS YOURSELF | 24

R-DESIGN | 26

COLOURS | 28

WHEELS | 30

PERSONALISE
YOUR INTERIOR | 32

UPHOLSTERIES | 34

ACCESSORIES | 36

FACTS AND FIGURES | 42

THE VOLVO
EXPERIENCE | 44

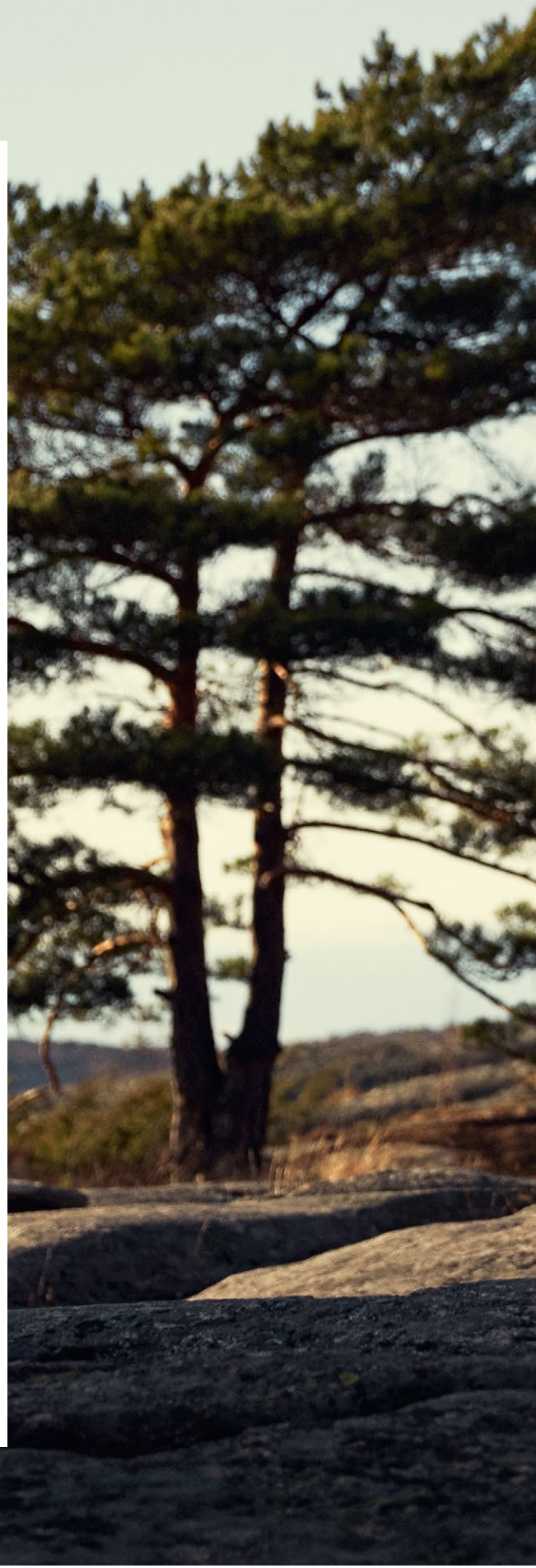





The new Volvo V60 is designed to fit in with your life, whatever you're doing. It's for people who need the versatility of an wagon but want the advanced handling of a modern sportswagon. So, as well as having all the comfort and space you'd expect from a Volvo wagon, this is a true driver's car – and you'll know what we mean if you're the kind of person who prefers to take the long way home.

At the heart of the Volvo V60's dynamic, natural driving experience is a great chassis. We're proud of the standard Dynamic Chassis (D4 model only) – we've spent thousands of hours perfecting and tuning it, and heightened its responsive, in-command driving experience.

And as soon as you get behind the wheel, you'll discover another great example of outstanding Scandinavian design around people. Seats have been a Volvo strength since the 1970s, when we enlisted ergonomic experts to help us develop a supportive shape that ensures you arrive fresh and relaxed after even the longest journey. With the Volvo V60, we've been able to retain the comfort but

make the seats even sportier, as befits a true driver's car.

Then, there's the sheer build quality. You can always tell true craftsmanship by looking at the details. The Volvo V60 has beautifully styled integrated tailpipes, which are the physical and visual link to our technically advanced, highly efficient new generation of powertrains.

A dynamic driver's car also needs to have impact: we've all been in a situation where you look in your rear-view mirror and see a really striking machine. The Volvo V60 has that kind of look. With its strong shoulders and V-shaped bonnet, it's unmistakably a Volvo and carries itself with pride. The wide grille seems ready to inhale the road ahead of it while the expressive headlights appear as if they've been shaped by the wind at high speed. To add to the road-hugging expression, we've positioned the daytime running lights close to the ground. Together with the distinctive falling roofline, the design elements create that feel of urgency and pace that suits the Volvo V60's character so well.





“The Volvo V60 is for people who need the versatility of a wagon but want the advanced handling of a modern sportswagon.”

VOLVO V60

Why give up the thrill of driving just because you need to carry stuff?

The Volvo V60 is a beautifully balanced combination of dynamism, style and versatility. For 2015, we've given our sportswagon a host of upgrades. In our on-going quest to give you more power at lower fuel consumption, you can now choose from our highly efficient Drive-E powertrains, both in petrol and diesel. Then there are our gearshift paddles,

which let you shift up and down the automatic gearbox in manual mode without taking your hands off the steering wheel. Inside, you'll love the sheer comfort and versatility of the interior cabin – the backrest splits in 40/20/40 segments. Sensus Connect ensures you're never offline on the road: thanks to internet connection, you'll

have the web and apps at your fingertips. Then, there's Premium Sound by Harman Kardon®, which makes you experience your favourite music in an entirely new way. Finally, there are a range of colours and wheel designs to choose from.







It's not your usual wagon.

We've worked hard to combine the versatility and load-carrying capability of the Volvo V60 with natural driving dynamics so that – like its sister, the S60 sedan – it responds faithfully to your desires.

When you accelerate out of a tight corner, for example, your V60 will follow the path you choose with almost telepathic accuracy. A good chassis is the essential foundation for this, and you can choose from three types according to your preferred driving style: Dynamic, Four-C and Sport chassis.

At the heart of versatility is the intelligent seating. The backrest can be easily folded down in 40/20/40 segments to supplement the rear 430 litres of load space, while the front seat backrest can be folded down, too. And parents will love the two-stage integrated booster cushions for children: they fold out of the rear seats, ensuring that kids who've outgrown their child seats are at the correct height for their seatbelts to work effectively.



*“We’re famous for our seats
– they’re a proud tradition for us at Volvo Cars.”*

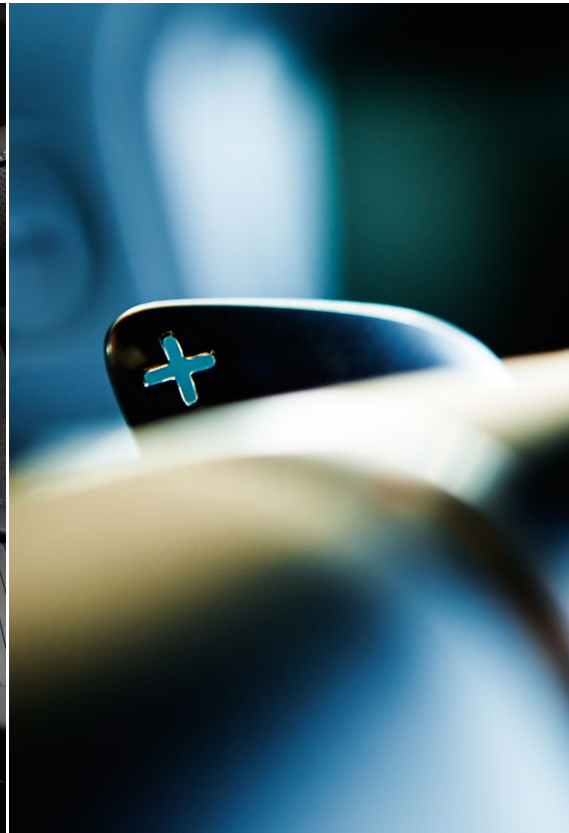

We've designed the cockpit around you, the driver. Get inside and feel in complete command as the dashboard gently angles towards you. We were inspired by high-performance motorbikes when we came up with the idea of a single round instrument flanked by two smaller dials. Then, we carefully sculpted the three-spoke steering wheel with the aim of giving you a very physical sense of connection between your car and the road. But where you sit is even more important. “We’re famous for our seats,” says V60 Program Manager Stefan Sällqvist. “They’re another proud tradition

for us at Volvo Cars. Our sport seats look fantastic and, true to our unrelenting commitment to ergonomic design, you'll be able to drive for hours sitting in them without getting tired. They also have great side support all the way from your thighs to your shoulders, so the seats keep you firmly in position even when you're cornering fast.”

And because it's a Volvo, we designed the seats so your passengers will enjoy the ride, too. Everybody travels first class, and with our two-stage integrated booster cushions children over 3–4 years will ride safely in comfort while seated at the right position.

No need to take your hands off your steering wheel as you shift up and down the automatic gearbox in manual mode – just flick through the gears with our gearshift paddles. You'll be in total command of your car, with both hands on the wheel. And quicker gear changes give your drive an additional edge when you're in the mood for upping the tempo.



“The car has a beauty that – as with much of contemporary Scandinavian design – is rooted in the natural world.”

HOW DO YOU MAKE A BEAUTIFUL WAGON?

By design.

The looks tell you this car is a beautiful combination of versatility and performance. “The road presence comes from its focused and determined-looking headlights,” explains our Senior Exterior Designer Peter Reuterberg. “We were thinking of a wolf’s eyes when we designed the car’s ‘face’. It has a confident, focused expression, like a powerful animal.” Our designers have also made the roof sweep down and the rear

windows taper; the overall effect is to make it appear more like a coupe. The scalloped surfaces on the bonnet accentuate the classic Volvo V-shape with a purposeful frown running right down to the headlights. The car has a beauty that – as with much of contemporary Scandinavian design – is rooted in the natural world. “Those clean surfaces and contours give it a very Scandinavian feel,” says Peter. “The way

surfaces build up and then change shape is inspired by snowdrifts in the Swedish countryside – it’s a combination of soft forms and sharp breaks.” The strong shoulders are another unmistakable Volvo design cue – as is the expressive grille with the iconic Volvo diagonal. They enhance the car’s self-confident look and tell the world it’s proud to be a Volvo.



“Sensus is about making your interaction with your car intuitive, and ensuring you’re on the road, but not offline.”

SENSUS

The intuitive way to interact with your car.

Volvo Sensus is our all-encompassing approach that connects you with your car and the world around you. It means you're on the road, but not offline. With Sensus Connect, you can turn the 7-inch screen in your dashboard into an internet-connected infotainment hub. Not only can you surf the web, you can also download various apps.

Sensus Connect also gives you access to basic internet maps and routing, and to take advantage of navigation guidance, 3-D views and navigation apps, there's our Sensus Navigation. Connected Service Booking allows you to book your car in for a service from the comfort of the driver's seat.

A high-end audio experience is also part of Sensus. That's why we've designed our state-of-the-art Premium Sound with Harman Kardon®. Using 12 high-fidelity loudspeakers, the amplifier is equipped with Dirac Live®, the next-generation sound enhancement software. With an incredibly realistic stage sound as well as enhanced bass performance, this sound system provides an unparalleled aural experience for every passenger and connects easily with external media players.

Our digital driver display is another delight. Not only does it give you all the information you need without overwhelming

you, its three background modes – Elegance, Eco, and Performance – also sync with the centre screen. The physical controls, such as our floating centre stack with its iconic 'manikin' climate control buttons, are another example of Swedish design that's both functional and beautiful. And then there's our eye-catching illuminated gearshifter. Glowing gently in the dark, it adds a touch of atmosphere to your night drives.



SENSUS



*“Our vision is to design cars
that should not crash.”*

INTELLISAFE

Intuitive safety by Volvo Cars. For you, and for those around you.

At Volvo Cars, safety is an intrinsic part of our DNA. We've invented some of the world's most pioneering life-saving technologies – such as the three-point safety belt that's been acknowledged as one of the most important innovations of mankind.

But we aim higher. Our vision is to design cars that should not crash. In the shorter perspective the aim is that by 2020 nobody should be killed or seriously injured in a new Volvo.

IntelliSafe is our approach for a more harmonious relationship between cars and people. To achieve this, we have infused your Volvo with smart, intuitive innovations for a safer drive. And the IntelliSafe technologies help protect not only the people inside your car – we also consider people on the outside, for example with technology that helps you to detect pedestrians and cyclists.

When you drive at speeds up to 50km/h, our City Safety collision avoidance technology looks ahead of you and brakes automatically

if you're about to run into a vehicle in front. To give you more support at higher speeds, our Collision Warning with Auto Brake and Pedestrian and Cyclist Detection alerts you if you're too close to a vehicle and a collision is imminent – day or night. During daylight, the system also reacts if there's a pedestrian in your path or a cyclist ahead travelling in the same direction as your car. And should you not react to the warning, your car brakes automatically to help you avoid or mitigate a collision.

If your car should begin to drift between the lanes, our Lane Departure Warning will alert you to stay in the lane. There's even Driver Alert technology that reminds you to take a break in case your driving behaviour shows signs of drowsiness.

Our IntelliSafe technologies also support your daily driving. The Road Sign Information technology keeps you updated on actual speed limits and other important road signs. At night, our Active High Beam stays on high

beam all the time to optimise your vision without dazzling other road users. And to make you a bit more relaxed on the road, our Adaptive Cruise Control can maintain your set speed and distance to the vehicle in front. In slow-moving city traffic, our Queue Assist function can automatically maintain the selected distance to the car in front – from standstill and up to 30km/h. Our BLIS system helps you to early detect other vehicles in your blind spot, while the Cross Traffic Alert function facilitates reversing out of tight parking spaces where your vision can be restricted.

And because we know you love to drive, our active IntelliSafe technologies like Electronic Stability Control add to reassuring driving stability in all conditions without sacrificing the joy of driving. It's simply about giving you the most human driving experience, on your terms. And helping to keep people out of harm's way, whether they happen to be inside or outside your car.



Light up the dark. Driving in the dark just became a lot more enjoyable and safer. Our Active High Beam stays on high beam all the time. You don't have to flick between low and high beam, and when you meet or catch up another vehicle the system shades out only as much of your beam as necessary to avoid dazzling – while you still get the benefit of a brightly lit road. This intelligent technology can even recognise pedestrians and cyclists and avoid dazzling them, too. And when you enter a city, the high beam shuts off.

FIND OUT MORE AT VOLVOCARS.COM.AU



In town, City Safety is designed to prevent you from colliding with the car in front if it stops, or slows suddenly. This advanced IntelliSafe system will brake automatically to avoid a crash and works at speeds of up to 50km/h. An accident can be avoided at a speed difference of up to 15km/h to the vehicle in front.

Because we also care about other road users, our Pedestrian and Cyclist Detection with Full Auto Brake watches out for people walking in your path or cycling in the same direction as your car, and applies the brakes automatically if you're unable to react in time.

Our BLIS system uses radar sensor technology to alert you to vehicles that are close to or in your blind spots in your adjacent lane. This way, you're far less likely to change lanes when it isn't safe.

When you're reversing out of tight parking spaces, our Cross Traffic Alert function watches out for vehicles you can't see.

READ MORE AT VOLVOCARS.COM.AU

INTELLISAFE





“Our commitment to performance at ever-lower fuel consumption means that our entire powertrain range will soon consist of a new generation of highly efficient 2.0 litre four-cylinder engines.”

DRIVE-E

Enjoying more. Using less.

Drive-E isn't just about our new generation of efficient powertrains, it's about our all-embracing approach to sustainable driving. And while we're committed to creating smarter, more innovative technologies to reduce our cars' impact on the environment, we'll never lose sight of the pleasure to be had in driving. We believe you don't need to sacrifice power and superb driveability for efficiency and low CO₂ emissions.

Our Drive-E powertrain range consists of highly efficient 2.0-litre four-cylinder petrol and diesel engines. We've mated these turbocharged, low-friction, light-weight powerplants to Geartronic[®], our all-new eight-speed automatic gearbox, which ensures you get optimum performance at any engine speed.

Your Volvo also has an ECO+ function, which can reduce fuel consumption by up to five per cent, depending on driving style. ECO+ not only optimises shift points, engine control and throttle response, it also includes Stop/Start engine technology and an ECO coast function. This latter function disengages the clutch when you release the accelerator at speeds above 65km/h: instead of the engine braking the car and using up fuel in the process, your Volvo will coast along using its kinetic energy.

Our Drive-E diesel powertrain has additional technologies designed to reduce fuel consumption and emissions. Twin turbochargers and the revolutionary i-ART – where each cylinder has its own microchip and pressure sensor for perfect metering of

fuel – ensure that these intelligent engines provide responsive, clean and efficient performance. Better still, these advanced engines remain in precise tune even after years of use.

Of course, we're committed to a clean environment inside your car as well. As part of CleanZone, all materials in your Volvo's interior are hypo-allergenic and do not emit harmful gases. CleanZone also includes a highly effective dust and pollen filter. You can boost this further with our Interior Air Quality System. This uses an active carbon filter to reduce harmful gases and particles, enabling you and your passengers to breathe easy – even in polluted cities.

The Volvo V60 is available with cutting-edge petrol and diesel engines designed to meet your preferences. Both are designed to offer maximum driving pleasure while using fuel efficiently and keeping CO₂ emissions at a minimum.

Is fuel economy your priority? Then choose our 140kW D4 engine, which consumes just 4.5l/100km and emits 117g CO₂/km. Our petrol offering is the turbocharged T5 that produces 180kW and helps propel the V60 from 0-100km/h in 6.4 seconds.

READ MORE AT VOLVOCARS.COM.AU



DRIVE-E





Which Volvo V60 are you?

Congratulations, you've chosen a Volvo V60. Now you've decided on your preferred engine, all you need to do is select the trim level that's right for you. We've made it easy for you by

providing four that we think you'll love. Whether you'd like all the trimmings or a sporty look both inside and out, we have the right one for you.

LUXURY

Includes:

18" Wheel Titania diamond cut gloss black | Active Bi-Xenon Lights | Air Quality System | Airbag, driver & passenger side | City Safety | Cruise Control | Dynamic Stability Traction Control (DSTC) | Gearshift paddle | Home Safe Lighting | Keyless Entry and Drive with personal car communicator | Leather Upholstery | Power Passenger Seat | Power Seat Driver | Rain Sensor & Tunnel detection | Rear Park Assist Camera | Sensus Connect with High Performance Sound | Sensus Navigation | Shimmer Graphite Décor Inlays | Volvo Guard Alarm

R-DESIGN

Includes:

18" Ixion wheels | 3-spoke perforated leather-clad steering wheel with metal R-Design badge | Adaptive Digital Display with R-Design theme | Dual exhaust with visible tailpipes | LED dayrunning lights R-Design | Leather-clad sport gear knob | Nubuck textile/leather upholstery | R-Design interior decor trim | Rear-view mirror caps in silver metallic finish | Sensus Connect with Premium Sound by Harman Kardon | Sport chassis | Sport floor mats | Sport pedals | Sport seats | Stainless steel treadplates R-Design | Unique R-Design front design | Unique R-Design rear diffuser

RDESIGN



The R-Design story continues in the interior, starting with supportive sport seats in Nubuck textile and leather. Also included is an exclusive R-Design steering wheel as well as sport pedals. A gear-shifter gaiter with contrasting stitching, our unique blue R-Design digital driver display, interior LED lighting and a striking charcoal headliner all add to the R-Design experience.



“Our R-Design Sport chassis has been lowered and stiffened for even better cornering – meaning you’ll enjoy the thrill of driving your Volvo V60 even more.”



Would you like to enhance the dynamic personality of your Volvo V60 even further? Well, then R-Design is for you, with a range of features to give your Volvo a sporty, unique profile. But R-Design is so much more than a cosmetic exercise – as with the all best Scandinavian design, form follows function. R-Design benefits from a stiffer Sport chassis and more direct steering – meaning you’ll enjoy the thrill of driving your Volvo V60 even more.

For an exterior with a more individual, sporty look, R-Design offers gorgeously sculpted alloy wheels and unique door mirror covers in silver metallic. At the back, a motorsport-style diffuser enhances your car’s dynamic presence, while the R-Design chrome dual exhaust pipes add the perfect finishing touch to the exterior.

The exterior colour you choose has a dramatic impact on the personality of your Volvo. But no matter which you choose, each one imbues the car with a sense of luxury and presence.

“Our colour palette is very Scandinavian,” says Ebba Maria Thunberg, who is responsible for colours and material. “When you look at

our palette, you’ll find that it contains softer tones that are more connected with nature, with a few bold splashes.” Being Swedish, our designers are inspired by the ocean and the sky, but also by the shore and the way the light changes throughout the seasons. Every tone speaks of uniqueness, quality and charisma.



614 Ice White
(Also available for R-Design)



707 Crystal White Pearl
(Also available for R-Design)



477 Electric Silver metallic
(Also available for R-Design)



713 Power Blue metallic
(Also available for R-Design)



487 Ember Black metallic



717 Onyx Black metallic
(Also available for R-Design)



484 Seashell metallic



702 Flamenco Red metallic



467 Magic Blue metallic



711 Bright Silver metallic



019 Black Stone



492 Savile Grey metallic
(Also available for R-Design)



714 Osmium Grey metallic
(Also available for R-Design)



612 Passion Red
(Also available for R-Design)



Pallene, 7x17"
Silver



Rex, 7x17"
Silver Bright



Portia, 8x19"
Top Cut/Silver Bright



Sadia, 8x17"
Silver



Portia, 8x19"
Diamond Cut/Glossy Black



Ymir, 8x18"
Diamond Cut/Glossy Black



Hera, 7x16"
Silver



Ixion, 8x18"
Diamond Cut/Dark Grey
(R-Design)



Bor, 8x19"
Diamond Cut/Matte Tech Black



Titania, 8x18"
Diamond Cut/Glossy Black



Skadi, 8x18"
Silver Bright



From expressive to discreet, elegant to sporty, you can give your Volvo V60 a unique twist by the wheels you choose.

Would you like to make an entrance or do you prefer the charm of the understated? Are you going for a sporty persona or an intricate, refined look? Try different wheels on our online configurator and find the one that's right for you.

Ixion II, 8x19"
Diamond Cut/Matte Black
(R-Design)

Your Volvo V60 is your
home away from home.
Give it your signature.



Choose a Volvo V60 and you'll enjoy an elegantly designed cabin as standard, with a superior finish in evidence everywhere you look – from the silk metal finish on our air vents to the fine cloth surfaces on the door pillars.

Our Comfort seats are upholstered in leather as standard, while our Sport seats in leather give you legendary Volvo comfort

while also keeping you firmly in place in those fast corners. And for added control, our gearshift paddles allow you to change gears with the flick of a finger whenever you have the automatic gearbox in manual mode – so you never have to take your hands off the steering wheel while driving. It's a great feature for added control. You can go one better by choosing our heated steering

wheel, which lets you gently warm your hands in cold conditions.

And with our heated windscreen, you'll never have to stand outside scraping ice off the glass in the freezing cold. Once you're in the driver's seat, you'll appreciate the easy-to-read digital driver display.





Sport seat



Comfort seat

INLAYS



Urbane Wood

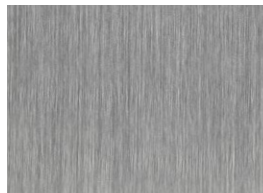

Aluminium



Shimmer Graphite aluminium



Piano Black

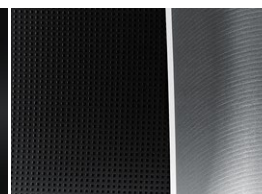

R-Design



Leather

Sport Leather

**R-Design Textile /
Perforated Leather**

**R-Design Leather /
Perforated Leather**



NE

START
STOP
ENGINE



RADIO MEDIA TEL MY CAR

1 2 ABC 3 DEF

OK MENU

“Our Park Assist Camera, Front Blind View allows you to ‘see around corners’ as you negotiate tight exits.”

NO TWO LIVES ARE THE SAME.

Make sure your Volvo matches yours.

The most pleasurable part of buying a new Volvo is putting your personal stamp on it. You can do that by choosing accessories that reflect your own taste and that cater to your particular lifestyle.

There's nothing more challenging than trying to negotiate tight exits and junctions with restricted visibility. Our Park Assist

Camera, Front Blind View, takes the stress out of these situations. It allows you to 'see around corners' with a 180-degree field of vision in front of you. The image is projected onto your 7-inch centre display so you know exactly who, or what, is approaching.

Since there can only be one driver at a time, the Volvo V60 also offers some

premium amusements for your rear seat passengers. Our Rear Seat Entertainment system with 8-inch touchscreens and integrated DVD players can operate independently. Wireless headphones are standard (you can also plug in your own wired headphones), so one's game doesn't fight with another's movie.

To reinforce the dynamic stance of your Volvo V60, you can customise it with our Exterior Styling Accessories, which are available in Matte Terra Bronze, Matte Silver or Matte Iron Stone.

Our eye-catching front skid plate gives your Volvo V60 an even more purposeful look, with a metallic finish that's beautifully accentuated as it catches the light.

The side scuff plates emphasise the Volvo V60's sleek, coupé-like lines, visually connecting it close to the road. The rear skid plates with beautifully sculpted double integrated tailpipes boldly underline the V60's sporty character.

READ MORE AT VOLVOCARS.COM.AU

The wheels are the jewels of your car. Our gorgeous 18" Modin wheels feature a Diamond Cut five double-spoke design. They, too, are available in Matte Terra Bronze, Matte Silver or Matte Iron Stone.







No matter what you like to do in your spare time, there's a pack & load accessory for you. Our exclusive, aerodynamic Space Design roof box looks great, is voluminous, and offers minimal wind resistance. It can be opened from both sides and is available in Titan Silver or Black, as well as two sizes: 320 or 430 litres, with a maximum load of 75kg.



“With the dog gate, you can open the tailgate without your dog leaping out – which makes life so much easier.”



For the load compartment in the rear, there's our steel safety grille, which is an alternative to the standard safety net. This gas-sprung steel grille is colour-coordinated with your interior and helps to protect you and your passengers from unsecured loads when braking sharply. And when you don't need it, it folds conveniently up against the roof.

Our load compartment divider is another great accessory. Used together with the steel

safety grille, this divides the load compartment into two sections – convenient if you want to carry your dog and luggage, or to separate grimy or fragile cargo from other cargo.

Finally, to give your pet a place of its own, you can complement the safety grille and load compartment divider with our dog gate. It allows you to open the tailgate without your dog leaping out – which makes life so much easier.

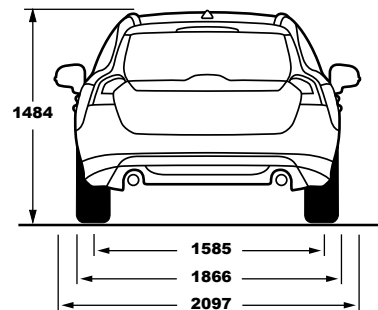
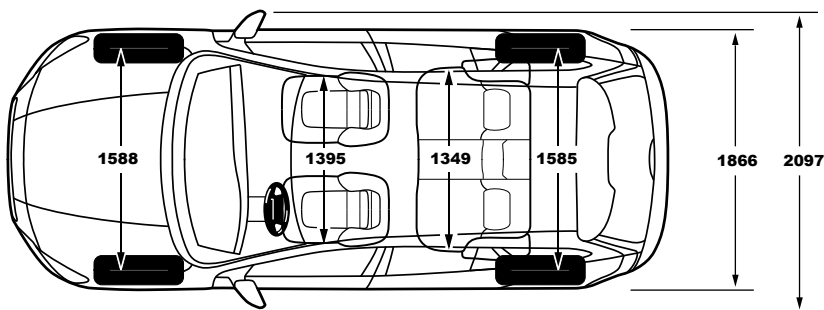
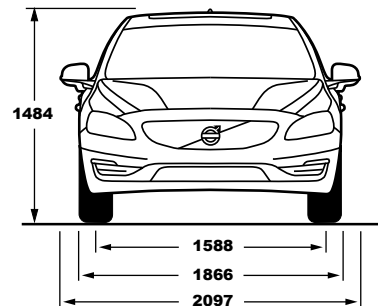
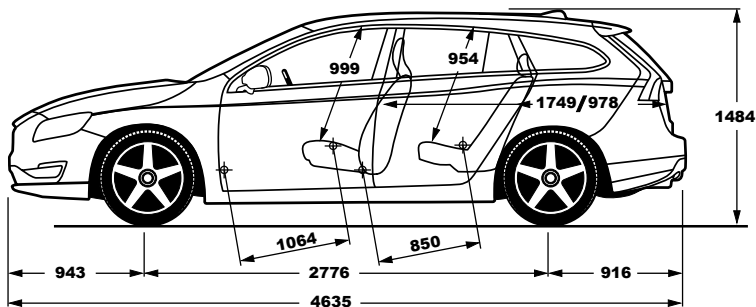

	T5	D4
Engine type:	2.0 I4 petrol turbo	2.0 I4 turbo diesel
Transmission:	Eight-speed Geartronic®	Eight-speed Geartronic®
Fuel consumption, litres /100 km, mixed cycle:	6.8	4.5
CO ₂ g/km:	156	117
Max. power output:	180kW at 5500rpm	140kW at 4250rpm
Max. torque:	350Nm at 1500-4800rpm	400Nm at 1750-2500rpm
Acceleration, 0-100 km/h in sec:	6.4	7.7
Top speed, km/h:	230	225
Fuel tank, litres:	67.5	67.5
Environmental classification:	Euro 6	Euro 6

NB. The engine programme may vary from country to country. All technical data may be subject to change. Please talk to your Volvo Car dealer for the latest information.

Polestar Performance software. Upgrade your car's performance with Polestar Performance software. Polestar are our racing partners. We've been using their expertise on the track to help us continually improve our engines' efficiency and performance.

FIND OUT MORE AT POLESTAR.COM



Please note: Some of the information in this brochure may be incorrect due to changes in product specifications that may have occurred since printing. Some of the equipment described or shown may now only be available at extra cost. Before ordering, please ask your Volvo Car dealer for the latest information. The manufacturer reserves the right to make changes at any time and without notice to prices, colours, materials, specifications and models.



V O L V O

V60

S MLB 060



The simplest way to own a car.

We love it when you're happy – when things are easier than you expect, or go faster and become better. Because when you buy a Volvo, you buy the simplest way to have a car. Financing, insurance, servicing, changing tyres, cleaning – those aspects of car ownership that you might not find very

interesting are the ones that we love to make easier and better for you. That's why your Volvo Car dealer will always offer you a whole range of simplifying services and offers all designed around you, giving you the most carefree ownership experience possible.

Still, this is just the beginning. Through our uniquely Swedish approach to innovation, we continuously find new ways to make your life simpler. For instance, the Connected Service Booking* function, which lets you book an appointment just by pushing a button in your car.

BUYING & OWNING

- Warranties
- Financing
- Insurance
- My Volvo website

MAINTENANCE & SERVICES

- Volvo Service 2.0
- Volvo Professional Car Care
- Software Updates

IF SOMETHING HAPPENS

- Volvo Roadside Assistance
- Repairs
- Volvo Glass Services
- Volvo Dent Repair
- Car Climate Services

MY VOLVO

My Volvo is a personalised website that contains everything you need to really get to know – and get the most out of – your car. It gives you:

- A complete overview of your Volvo Car ownership
- Easy access to all facts relating to your car
- Helpful tips regarding your specific Volvo model
- Instructional films and owner's manuals
- Online Service Booking
- Reminders regarding important stages of your car ownership
- Exclusive articles, films and photographs

CONNECTED SERVICE BOOKING*

If your Volvo has Sensus Connect, it will remind you when it needs servicing and offer to contact your Volvo Car dealer for you. Booking proposals sent from your preferred dealer can easily be managed directly in the car or on your personal My Volvo website. When the time comes to drive to your workshop, your Volvo will remind you and even guide you there. And since your Volvo tells us what it needs, we can make sure it always receives the service it requires when it gets there.

*Available depending on introduction date. Please Contact your Volvo Car Dealer.

V O L V O