



THE ALL-NEW VOLVO V60



THERE'S MORE HERE THAN A NEW CAR. THERE'S LIBERATION FROM CONFORMITY. THERE'S THE RHYTHM OF THE CITY AND THE LULLABY OF THE COUNTRYSIDE. THERE'S THE EXHILARATION OF THE CURVE AND THE ADRENALINE SURGE OF THE STRAIGHT. THERE'S THE COURAGE TO EXPLORE.

THERE'S THE THRILL OF DISCOVERING SOMETHING NEW. THERE'S THE SATISFACTION OF BEING ABLE TO SHARE IT WITH THE PEOPLE YOU LOVE. AND THERE'S THE PLEASURE OF FINDING OUT IT'S JUST WHAT YOU'VE BEEN SEARCHING FOR: THE ALL-NEW VOLVO V60. THAT'S WHY YOU DRIVE ONE.





The workhorse gets wicked.

Like every example of change, it started with an idea. A spark that ignited imaginations, setting in motion an irreversible, irresistible chain of events. In this case, the idea was simple – create the world's sportiest, sexiest, most dynamic Sportswagon.

A million pulse-quickenning moments later, it's here. We call it the V60, but you'd be excused for using more emotional language. An enabling, revolutionary, unexpected, exuberant, intense, enchanting, poised, sophisticated and raw modern Scandinavian classic, perhaps? Call it what you like, but one thing is certain – you'll never call it ordinary.



From this day on...

You will refuse to compromise. You will avoid the default solution. You will demand more excellence. You will see more beauty. You will measure what is best with raised parameters. You will view normality on revised terms. You will allow your emotions to steer you onto new, exciting roads.

Now imagine an open road. Perfect driving conditions. A corner approaches. A smile plays on your lips. Our new improved Dynamic Stability Traction Control has that effect. Adrenaline surges, instinct kicks in – and Corner Traction Control has your back. A slight punch of the accelerator to take you out of the curve is echoed by a small, almost imperceptible skip of your heartbeat. Was that the Four-C semi-active chassis and Advanced Stability Control you just felt? Perhaps. But there's no time to dwell on that because you just felt an infinitely more powerful emotion – the promise of a world of possibilities ahead.



Playlists

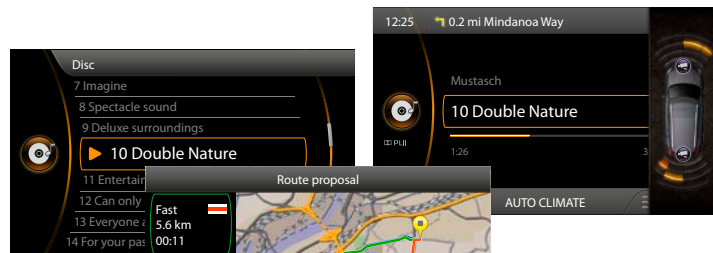

Maps



Park assist views

Personal settings



Man and machine. The conflict is over.

Getting the most out of every kilometre you drive involves many different factors. It could be argued that the most defining of these is your relationship with your car. Through the application of smart design we've created what we believe is one of the world's most agreeable, functional and comfortable driving environments: seats that support, caress and can be finely adjusted to suit the most demanding of drivers; a three-spoke steering wheel that exudes sporty confidence; a centre console angled slightly towards the driver for easy access to key functionality; materials chosen for their high quality, allergy-reducing characteristics and ultimate recyclability; ambient cabin lighting that sets a mood of sophistication and more. The details are as endless as are the possibilities. Thankfully, the new Volvo Sensus driver-control interface helps you manage your options.

This intuitive computer command system uses the built-in screen and a scroll wheel selector on the steering wheel to make it easy to personalise settings and get the most from all of your on-board technology. Information, entertainment, functionality are easily accessible, easily enjoyed and easily controlled. For man and machine, the conflict is over.

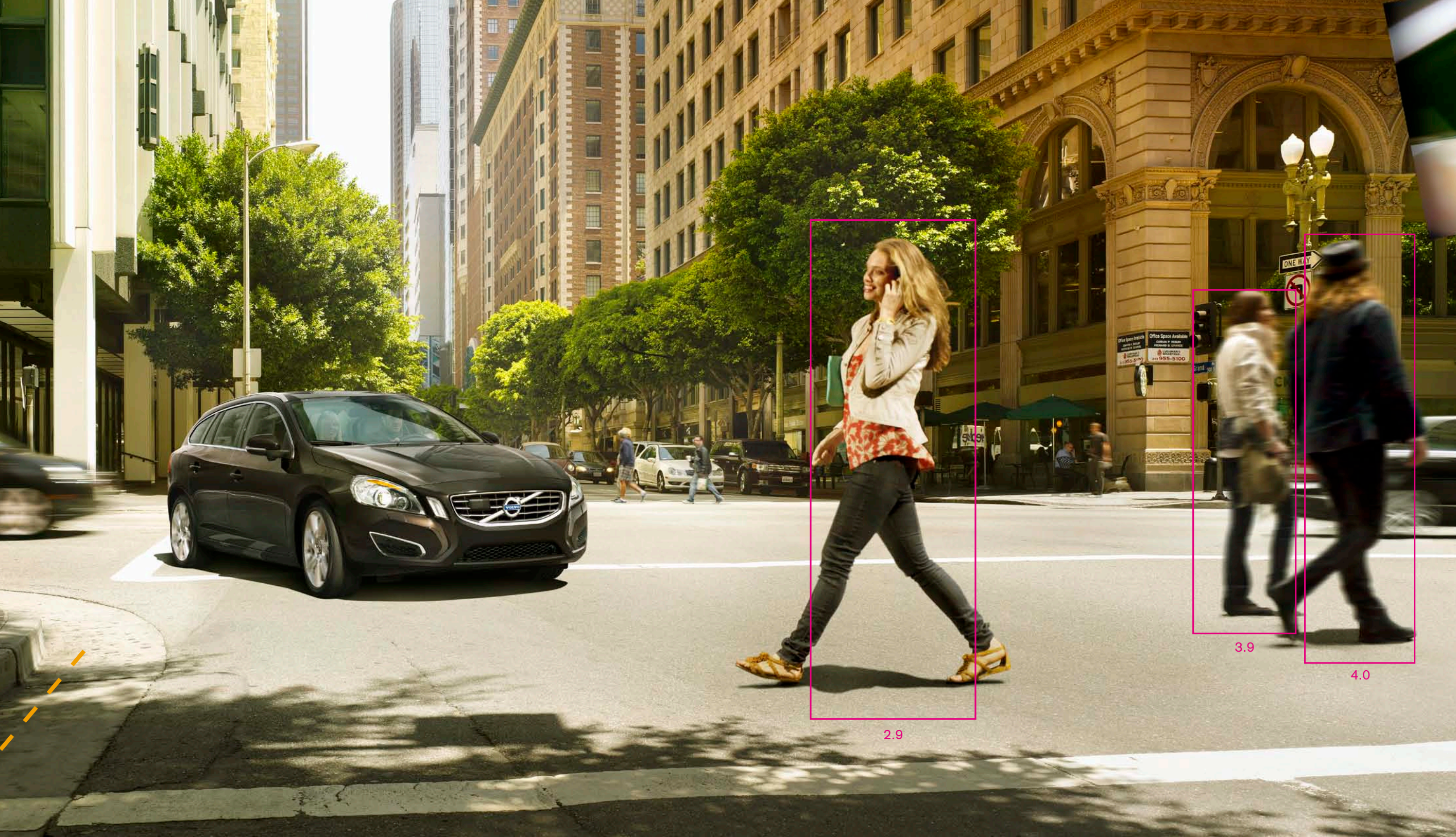

2.9

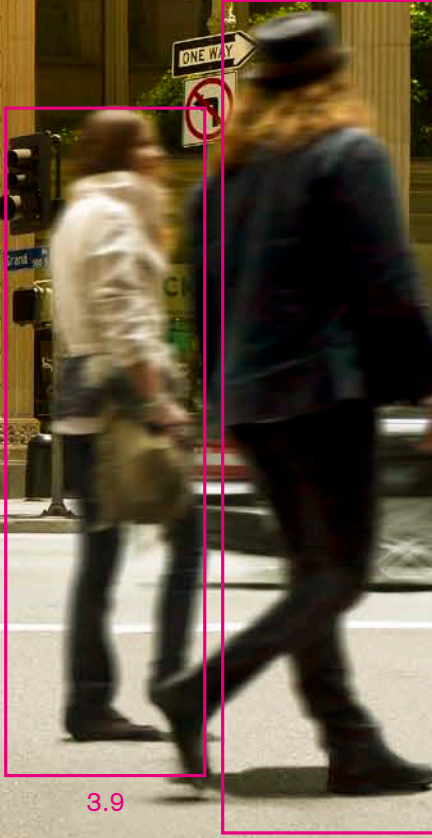

3.9

4.0



Avoid what you love most.

The V60 loves people. It welcomes them, embraces them, protects them, entertains them and exhilarates them. It also enables you to avoid them. How come? Well, we've created a smart new feature we call Pedestrian Detection with Full Auto Brake. As the name suggests, it detects pedestrians as you drive at speeds up to 35 km/h and if a potential hazard is detected, the brakes are automatically applied. To put it in more human terms, you can think of it as several extra pairs of permanently alert eyes.

Of course, we would never suggest that any function can replace safe driving, but by utilising our unique experience of innovative safety, you can now drive a car that literally takes safety onto the streets.



Relax. It thinks as fast as it moves.

An open road. You're behind the wheel of what is arguably the world's most dynamic Sportswagon. It doesn't get better than that, does it? Well, yes it does, because in the V60 you're also behind the wheel of a car that can see and think in remarkable ways. Take the Adaptive Cruise Control (at all speeds) feature, for example. It supports automatic cruising at speeds up to 200 km/h, ensuring your speed automatically adjusts to maintain a safe distance to cars in front. Should you find yourself in a situation where a collision is imminent, you'll receive a visual warning and if by chance you miss this, braking occurs automatically. We call it Collision Warning with Full Autobrake. We also call it simple – because the best ideas usually are.

City Safety. Mastering the unexpected with laser precision.

Always expect the unexpected – nowhere is this more evident than in urban traffic. That's why the advanced low-speed collision avoidance system City Safety comes as standard in your Volvo V60. Utilising laser technology and active up to 30 km/h, this high-precision system keeps a lookout on the road 6–8 metres ahead. If a vehicle suddenly brakes in front of you and a collision is imminent, City Safety will intervene and brake automatically to help avoid or mitigate a collision. Very courteous in slow-moving city traffic – for you, your passengers, your insurance company and anyone in the car in front of you. Almost like a sixth sense tuned into the city. Sounds like simple common sense to us – which perhaps explains why you'll find it in a Volvo.





Look left. Look right.
Now try both at the same time.

They say that you never know what's around the corner. At Volvo, we don't agree – and we present the front blind view camera which you can add to your V60 as our evidence. Mounted in the front grille, this camera sends a split-screen image of the 180-degree view in front of the car to the dashboard-mounted screen. It is designed to assist when pulling out into blind crossings, leaving tight parking spaces or managing any other driving dilemma that could benefit from an extra pair of eyes – or two. Complement with a rear-mounted camera and this innovative feature takes safety into new territory. Or if you prefer, just around the corner.

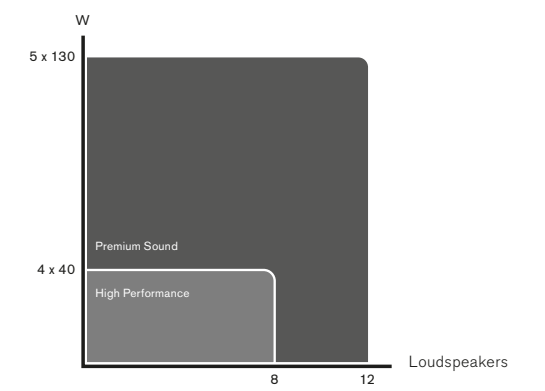

Front row seats or back stage passes. The choice is yours.

We made it our ambition to ensure you and your passengers enjoy superior entertainment. At the top of the range, you'll find our Premium Sound Multi Media system. Close your eyes and hear the difference Dolby® Pro Logic® II surround sound, twelve strategically placed speakers and MultEQ room reading technology make. Open them and see how a DVD player, a 7" in-dash colour screen and optional Rear Seat Entertainment screens can transform a drive into an event. Interact with it through standard USB/iPod® interface or wirelessly with Bluetooth®. Fully controllable from the steering wheel, this system delivers an experience that's as close to being there as it gets.

The more you put in, the more you get out.

Why limit adventures to the weekend? And why limit your adventures through your choice of car? After all, enjoying life to the max is all about making the most of our capacity. Speaking of which, check out the spacious luggage area on the V60 Sportswagon. Its split 40/20/40 rear seat makes transporting longer items simple without intruding on the wellbeing of your passengers. Good news for golfers and skiers among countless others. Other smart features include a lockable load floor, cargo divider and integrated two-step booster seats. Perfect should you have curious, junior VIP passengers on-board.

Style and driving pleasure, uncompromised by functionality. When it comes to what you do in yours, the V60 is a blank page – your story starts here.





Welcome to the drive-in theatre for the 21st century.

Driving the Volvo V60 provides all the entertainment one could require, but since there can only be one driver at a time, new world-class diversions are available for your passengers, too. Imagine this spectacle: DVD-video brilliantly displayed on a 7" colour screen and music expressed so cinematically that everyone aboard feels centre stage. The protagonists in this narrative are the new Multi Media systems and the deluxe

surroundings. Of course, the car must be parked to watch a video on the front screen, but while driving, song playlists, park assist camera views, navigational maps, personal settings and more can be displayed here using the Volvo Sensus driver-control interface and its scroll wheel selector on the steering wheel.





Audience participation encouraged.

Welcome. This is where comfort and refinement conspire to spoil you and your guests. Where sophisticated technology and premium materials reward each passenger at every turn. Where form follows function – all the way to fabulous. In absolute terms, this is what smart Scandinavian design by Volvo is all about.

Guests sitting in the rear seats (waiting to drive) can be pleasantly distracted by the Rear Seat Entertainment system (RSE). Its front headrest-equipped 7" screens with integrated DVD players can operate independently to suit each passenger.

Sweeping interior lines express the Volvo V60's flowing racetrack design concept. Realised using the finest safe-scent materials – with a fit, finish and environmental respect that set the standard for car interiors – every classy detail here serves a purpose.

Acclaimed year after year for having the most comfortable car seats in the industry, Volvo has expanded the definition of premium comfort to include cleaner cabin air. With the Electronic Climate Control (ECC), the Clean Zone Interior Package (CZIP) and the Interior Air Quality System (IAQS), sitting in a Volvo can be most refreshing.



A show of strength.

The V60 enjoys nothing more than the attention and company of loving people. But be reassured. When it comes to protecting you, your belongings and your passengers, it isn't afraid to show its teeth.

Personal security enhancements such as Approach and Home Safe Lighting and the Personal Car Communicator (PCC) all make sure that you know Volvo safety is at work even when your car is at rest. With the PCC fob, you can check the status of your car from a distance, open locked doors automatically when you grab the handle, and start the car with keyless convenience – just have the fob in your pocket or handbag.



INNOVATED FOR YOUR ENJOYMENT, VOLVO SAFETY TECHNOLOGIES WILL PROTECT MORE THAN THE FUN OF DRIVING.

Across the world Volvo is synonymous with advanced safety technology. And with good reason, because few car makers can match our record of safety innovations and the commitment to safety that has guided us for more than 80 years. Of course, this makes us extremely proud. But we're not satisfied. Because we know what we want to achieve: zero accidents. This huge task calls for innovative thinking and a brand-new approach to the way we design cars. The good news is that we've already come a long way. For starters, our cars are more fun and engaging to drive than ever. And the technology needed is no figment of the imagination – some is already available in your Volvo. This means driving a Volvo today is like having a first peek at a very exciting automotive future – a future where passionate engineering and design do more to empower you as driver.



EYES IN THE BACK.

Park assist and park assist camera let you know what's going on behind your car when reversing. This feature is also available for the front.

TOW IN HARMONY.

When towing, Trailer Stability Assist (TSA) helps counteract snaking tendencies from a trailer.

ALL-ROAD STABILITY.

Volvo's All-Wheel Drive (AWD) with Instant Traction™ enhances driving stability and traction in all weathers, in all seasons and on all roads.

PERSONAL GATEKEEPING.

Inspired by fighter aircraft technology, the Intelligent Driver Information System (IDIS) can help reduce your workload in stressful situations.

STAY ON TRACK.

Dynamic Stability and Traction Control (DSTC) improves handling, safety and fun in a wide range of challenging situations.

LOW-SPEED COLLISION AVOIDANCE.

City Safety – the world's first standard-fitted collision avoidance and mitigation technology – brakes your car automatically if you're about to run into a slower moving or stationary vehicle at speeds up to 30 km/h.

SEE AROUND CORNERS.

When parking or exiting a narrow lane, front blind view camera helps you discover what's approaching from the right and the left.

ON-ROAD ENLIGHTENMENT.

Active Bending Lights (ABL) with Dual Xenon technology expands your vision range when driving in the dark and provides considerably improved illumination around bends.

SMOOTH CRUISING AT ANY SPEED.

Adaptive Cruise Control (at all speeds) automatically maintains your set speed and distance to the vehicle ahead of you – whether you're driving on the motorway or in slow-moving stop-and-go traffic.

COLLISION AVOIDANCE AT ALL SPEEDS.

Collision Warning with Full Auto Brake (CWFAB) warns you if you're too close to the vehicle in front – at all speeds – and brakes the car automatically if a collision is imminent.

PEDESTRIAN DETECTION.

Using radar and camera technology, Pedestrian Detection with Full Auto Brake can detect pedestrians in front of your car and brake automatically if needed – a Volvo world first.

POSITION CONTROL.

Lane Departure Warning (LDW) warns you if you drift out of lane.

STAYING ALERT.

Driver Alert Control (DAC) alerts you if your driving behaviour shows signs of drowsiness or distraction and suggests a break.

AN EYE ON THE BLIND SPOT.

The Blind Spot Information System (BLIS) helps you detect vehicles entering your blind spot.

DESIGNED TO CATCH THE LIGHT BRILLIANTLY, A VOLVO ALSO REFLECTS A PROMISE.

Our journey towards a better environment started back in the early 70s. Then we were among the first car makers to acknowledge the environmental downside of cars and to do something about it. Since then we have been constantly innovating to reduce the environmental impact of our cars – all the way from product development and manufacturing to driving and recycling.

One of our biggest challenges is to reduce CO₂ emissions, which contribute to climate change. Our response is the technology and innovations developed within our DRIVE environmental program. For example, today we offer one of the premium segment's strongest ranges of low CO₂ alternatives. And consistently utilising innovative powertrain technology together with advanced aerodynamics, low friction technology and lightweight materials, DRIVE is an important step towards zero emissions.

In the near future we will be introducing new technology such as plug-in hybrid vehicles that will further reduce CO₂ emissions and can be charged from a standard wall socket. And we're heavily engaged in the development of electric vehicles – a technology that will dramatically reduce the environmental footprint of our cars and make them even more fun to drive. Fact is, we have already launched our first electric car – the Volvo C30 Electric – and more exciting news is on the way.

FRESH CABIN AIR.

Continuously monitoring the incoming air and shutting out carbon monoxide, ground-level ozone and nitrogen dioxide, Volvo's Interior Air Quality System (IAQS) helps ensure that the air you breathe in the car is cleaner than the air outside when driving in heavy city traffic.

85% RECYCLABLE.

To help minimise its total environmental impact, every Volvo is designed to facilitate recovery and recycling at the end of its useful life.

CLEANER EXHAUST.

Fast responding after a cold start, Volvo's advanced emission control eliminates between 95 and 99% of carbon monoxide, hydrocarbons and nitrogen oxides from petrol engine exhaust gases. The Volvo turbodiesels feature a particulate filter that removes about 95% of the particles from the diesel exhaust gases.

FROM 104 G CO₂ PER KM.

Our most eco-progressive engine alternatives, the CO₂ optimised Volvo DRIVE Start/Stop, are designed for best-in-class fuel efficiency – for minimum emissions and maximum style.



ALLERGY-APPROVED INTERIOR.

Clean Zone Interior Package (CZIP) provides cabin air that is so clean it is recommended by the Swedish Asthma and Allergy Association.

HEALTHIER INTERIOR MATERIALS.

All our upholstery and interior textiles are tested for specific allergy-inducing or harmful substances. And several interior metal details are tested with regard to contact allergies.

BIOETHANOL FOR LOWER FOSSIL CO₂ EMISSIONS.

Running on E85 bioethanol in a Volvo Flexifuel, you can significantly cut your greenhouse gas emissions. Because bioethanol is a renewable fuel, the carbon dioxide emissions from combustion are already part of the ecosystem and won't contribute to greenhouse gas levels in the atmosphere.

FUEL-SAVING DESIGN.

To reduce energy loss from air and roll resistance, we utilise advanced aerodynamic design, lightweight materials and low-friction technology. Together with state-of-the-art engine technology, this lowers your CO₂ emissions and helps you travel further on less fuel.

BRAKE FOR ENERGY.

For most of the engines, the battery is fed with extra power every time you brake. Smart and fuel-saving.

GREEN AT THE RED LIGHTS.

To further reduce fuel consumption and CO₂ emissions by up to 8% when driving in town, several engines feature Volvo's new Start/Stop technology.



Your Volvo V60 starts here.

The engine you choose will define a major part of the experience ahead. Some engines favour high performance, while others favour high mileage, but all of these petrol and diesel engines deliver instant power and smooth running while state-of-the-art technology makes the most of every micro-drop of fuel. Which engine is going to start you up? Find out more about the engines at www.volvocars.com.au

T5

205 CO₂ g/km | **8.7** l/100 km | **177** kW | **320** Nm | **Euro 5**

For the petrol head inside you, we loaded this new generation petrol turbo engine with the very latest technology. High precision direct-fuel injection together with Volvo's patented turbocharger and variable camshafts give this four-cylinder 2.0-litre power plant the powerful characteristics of a larger engine – without its high fuel consumption. You can enjoy instant acceleration, more responsive handling and a relaxed driving experience in all driving situations. Other fuel-saving features, such as brake energy regeneration, help keep carbon dioxide emissions low. Paired with a lightning quick dual-clutch six-speed Powershift automatic.

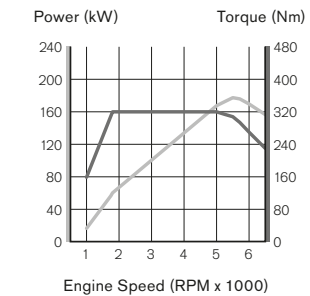

T4

181 CO₂ g/km | **7.8** l/100 km | **132** kW | **240** Nm | **Euro 5**

Get more from less. This newly developed four-cylinder 1.6-litre direct-injection petrol turbo engine combines an agile engine character with superior fuel efficiency. The direct fuel-injection technology reduces CO₂ emissions and fuel consumption, while the turbocharger provides this relatively small engine with the power and torque to deal with any driving situation. Low engine weight contributes to crisp handling on winding roads. This is downsizing everything except the fun of driving. The T4 is paired with a dual-clutch six-speed Powershift automatic.

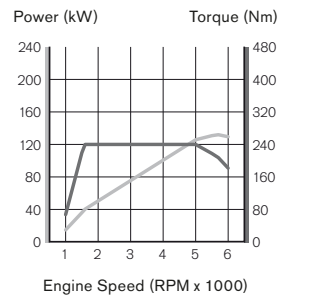

T6 AWD

247 CO₂ g/km | **10.3** l/100 km | **224** kW | **440** Nm | **Euro 5**

Enjoy the smoothness and dynamics of a supreme in-line six-cylinder petrol engine. The refined 3.0-litre T6 features a twin-scroll turbo for instant exhilaration at all revs – an impressive max torque of 440 Nm is at your disposal even at 2100 revs. This engine is the ultimate in both performance and comfort, while smart technology such as brake energy regeneration adds to high fuel efficiency. For even more sportiness, this engine is mated to Volvo's all-wheel drive with Instant Traction™ and a six-speed Geartronic automatic with sports mode.

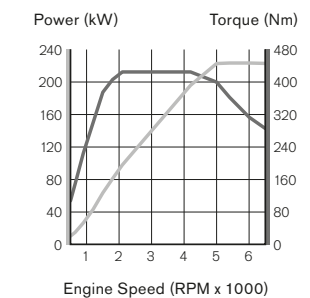

D3

160 CO₂ g/km | **6.0** l/100 km | **120** kW | **400** Nm | **Euro 5**

We designed the all-new 2.0-litre five-cylinder turbodiesel for a very special reason: to give you a top-notch driving experience in terms of refinement and fuel efficiency. The single turbocharger ensures immense power just above idling. The relaxed character and flexibility of this engine will infuse your drive with the composed feeling of being in control in all situations without compromising on the fun of driving. Superior mileage and low CO₂ emissions are there for you to enjoy. Further enhancing fuel efficiency, the D3 also features brake energy regeneration. This engine comes with a six-speed Geartronic automatic.

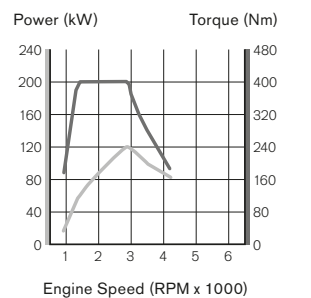

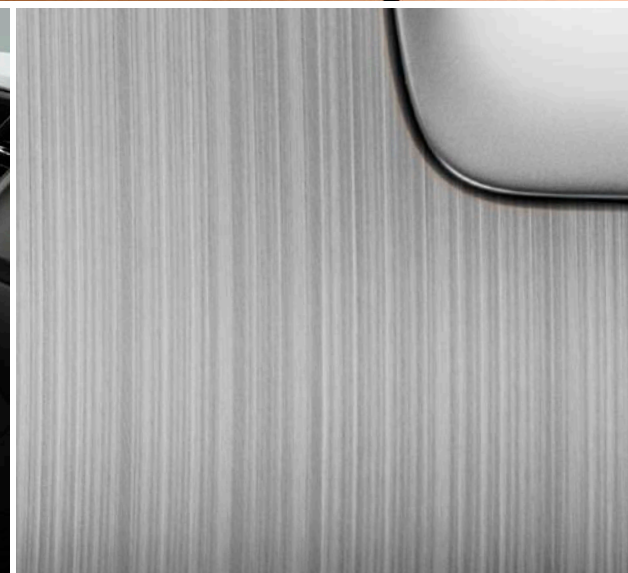

Thousands of combinations. Zero weirdness.

Add luxury and comfort beyond the impressive standard equipment level and imagine how you can further personalise your Volvo V60 with the options and accessories featured on the pages that follow. For more information, please contact your local Volvo dealer. If you don't see everything you want here, you can see more online. Find your personal Volvo at www.volvocars.com.au

V60

Includes:

40/20/40 split rear seat | 7" colour screen | Airbag, driver & passenger side | Aluminium decor inlays | Aluminium wheels | AUX input | B-pillar outlets | Belt reminder all positions | Car setting memory in key remotes | City Safety | Dual cup holders, front | Dual stage rear booster cushions outer seats | Dynamic chassis | Dynamic Stability and Traction Control (DSTC) with Advanced Stability Control, Corner Traction Control and Sports Mode | Electrically operated parking brake | Front and rear seat 12V outlet | Headlamp level adjuster | High Performance Multimedia Sound System | Illuminated vanity mirror, passenger side | Inflatable Curtains (IC) | Leather upholstery | Power driver seat with memory | Rear Park Assistance | Remote control central locking | Side airbags | Temperature gauge, outer | Trip computer | Whiplash protection, front (WHIPS)

R-DESIGN

Includes:

Lowered Sports chassis | R-DESIGN front with larger air intakes | High gloss black grille with R-DESIGN emblem and frame in Silk metal finish | Rear-view mirror caps in Silk metal finish | Rear diffusor | Dual sports endpipes | Ixion 8x18" aluminium wheels | Sports seats | R-DESIGN upholstery with front seats embossed with R-DESIGN logo | 3-spoke perforated Leather-clad steering wheel with metal R-DESIGN badge | Leather-clad sports gear knob | Sports floor mats | Sports pedals | Sports watch-dials with blue inserts | R-DESIGN interior decor trim inlays

Exterior styling accessories

Includes:

Freja 8x18" aluminium wheels (available in two colours, Diamond cut/Dark Grey Matt and Diamond cut/Light Grey) | Front skidplate | Front deco frames | Rear skidplate | Side scuff plates | Visible endpipes (available for all engine variants, both single and double endpipes)

The exterior styling accessories can be fitted to all engine and equipment level variants.

Want a dynamic touch?

Be one with your V60. Your body is held firmly yet comfortably in place by the Offblack leather sports seats. The leather-clad steering wheel with Silk Metal inlay and leather-clad gear knob are moulded to fit in your hands. The watch-dial gauges give you instant and vital information. Shimmer Graphite Aluminium centre stack adds to a distinctive air of sportiness. So if stylish and sporty looks set your pulse racing, this may be Volvo V60 for you. Here shown in Black Stone with Sleipner 18" aluminium wheels and accessory endpipes.



Or modern luxury?

Soothe your senses surrounded by sophisticated timeless elegance. Meticulously crafted sports seats upholstered in Soft Beige leather add to an uplifting yet relaxed experience. The leather-clad steering wheel and gear knob are soft to the touch. State-of-the-art supportive technology is within easy reach in the centre stack, featuring authentic Urbane Wood for an unmistakable Scandinavian flair. Elegant from inside and out, this Volvo V60 is painted in Flamenco Red metallic and features Njord 17" aluminium wheels.





R-DESIGN.

Proud sponsor of the unfair advantage.

Choose Volvo V60 R-DESIGN variant and the V60 receives a first-class attitude adjustment – inside and out. Boldly provocative yet tastefully reserved, the exclusive R-DESIGN styling elements and special chassis express a definitive passion for sport. From its aggressive prow with larger intakes to the rear diffuser with dual tailpipes, Volvo V60 R-DESIGN exudes confidence at every turn.

And it's in the turns where the advanced R-DESIGN chassis really makes a difference in handling. Lowered by 15 mm, this sports chassis is perceptibly and materially different. New anti-roll bars, new rear dampers (monotube concept), 15% stiffer springs, quicker steering, a rally bar and more have all been sports-tuned for more road-hugging control. Dynamically expressive, flawlessly synchronised and beautifully balanced, this R-DESIGN chassis amplifies the swift agility and sweeping artistry of this European Sportswagon.



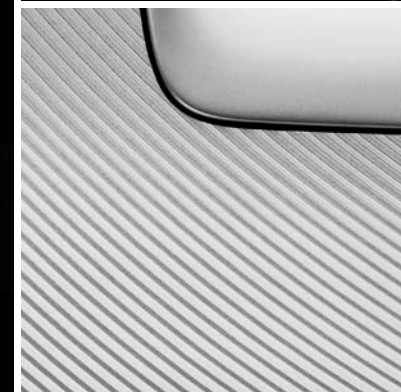

There are times in life when you have to turn up the volume.

The V60 R-DESIGN dials up the physical and emotional dynamics beautifully. Outstanding R-DESIGN elements include the five-spoke Diamond cut Ixion aluminium wheels (18"), specially stitched and embossed R-DESIGN sports seats, and an exclusive leather-clad, 3-spoke steering wheel with a stamped-metal R-DESIGN badge. Blue watch-dial accents also give you a pleasant reminder that you're driving something special every time you check the speedometer and rev counter.

Sports gearshift knob

Perforated leather gives the R-DESIGN gearshift knob a performance-ready look and feel.

Sports pedals

Racetrack-inspired to enhance the driving experience – enjoy the feel of these ridged sports pedals.

R-DESIGN upholstery

Enjoy unique Flextech/textile/leather upholstered seats with contrast stitching. Choose Offblack/Offblack or Offblack/Ceramic Light. Or choose leather upholstery in Offblack with contrast stitching.

R-DESIGN deco inlay

The centre stack's aluminium inlay conveys a contemporary feel, enhances the overall modern Scandinavian design and sets the tone for sports.

Sports floor mats

Exclusive, hand-tufted sports mats with accent ribbing provide a stylish welcome.



Colour your Volvo.

When it comes to the appearance of your Volvo, the choices of exterior colour, wheels and other styling items are probably your most important design decisions. For more exterior styling options and to build your new Volvo online, please visit www.volvocars.com.au



614 Ice White
(also available for R-DESIGN)



481 Cosmic White metallic



426 Silver metallic



477 Electric Silver metallic
(also available for R-DESIGN)

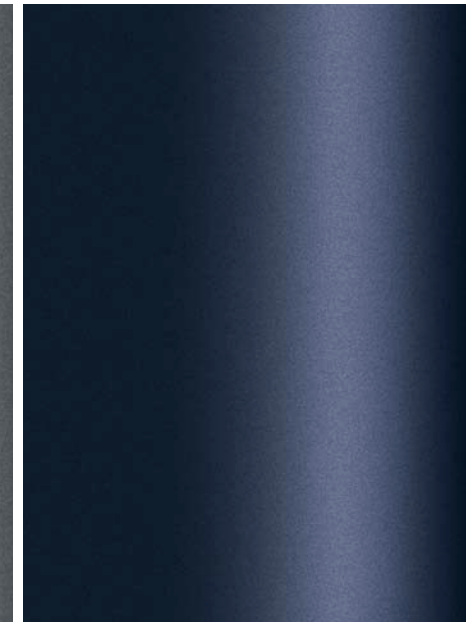

498 Caspian Blue metallic
(also available for R-DESIGN)

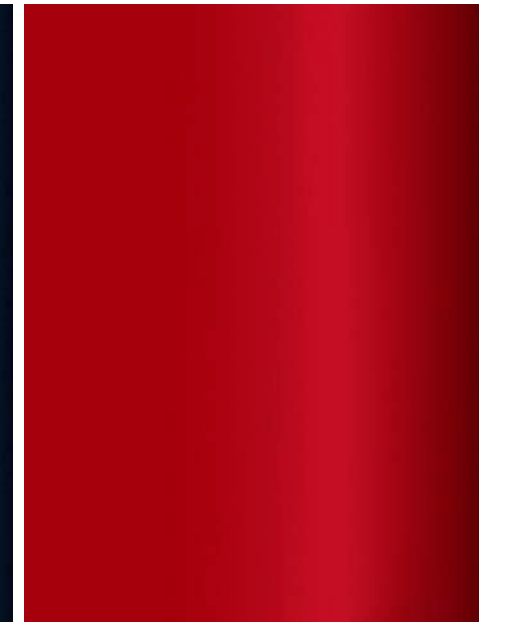

612 Passion Red
(also available for R-DESIGN)

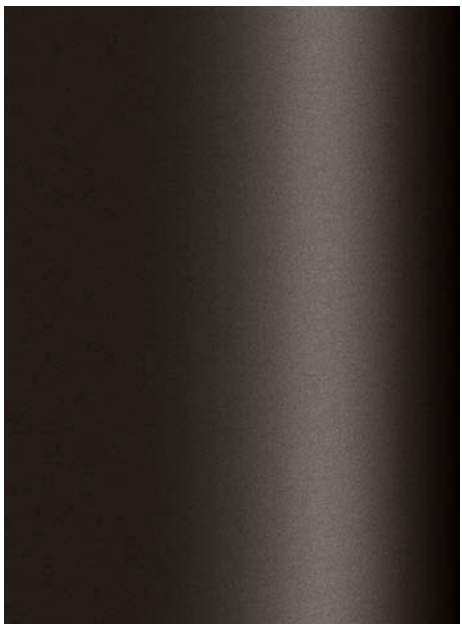

702 Flamenco Red metallic

484 Seashell metallic

703 Electrum Gold metallic

704 Vibrant Copper metallic
(also available for R-DESIGN)

492 Savile Grey metallic
(also available for R-DESIGN)

487 Ember Black metallic

452 Black Sapphire metallic
(also available for R-DESIGN)

019 Black Stone

Please note: It's not possible to reproduce exact original shades in printed matter. Please ask your dealer to show you samples.



Aluminium wheels – accessories



Freja, 8x18",
Diamond cut/Dark Grey Matt

Freja, 8x18",
Diamond cut/Light Grey

It doesn't have to match the drapes.

It's up to you. Add the exterior styling accessories and any preconceptions about what defines pure passion are upgraded here. More assertive than conventional street wear, these exterior styling accents reflect a spirit of independence and a belief in personal freedom. Oh my! What will the neighbours say?

The exterior styling accessories include a front skid plate, a rear skid plate with visible exhaust pipes (single or double pipes depending on your engine specification), side scuff plates, dual front deco frames (all in matt aluminium finish), Diamond cut 18" Freja wheels (in Dark Grey matt or the Light Grey shown here). These assertive details accentuate the road-hungry stance of Volvo V60. Find your favourite wheels and styling accessories at www.volvocars.com.au

Aluminium wheels – optional



Sleipner, 8x18", Silver Bright

Njord, 8x17", Silver Bright

Balder, 7x17", Silver Stone



Leather

These leather-faced seats give the Volvo S60 an atmosphere of luxury. It's a hide quality that's smooth and durable – with a coarse grain pattern on the centre panels and a finer grain on the outer panels. Like all Volvo leather, it's organically tanned and ages beautifully.

Seat colour	Interior colour	Leather-clad steering wheel	Instrument panel Upper part/lower part	Door panel inserts	Mats	Rooflining
Soft Beige	Sandstone beige	Charcoal	Espressobrown/Soft Beige	Soft Beige	Mocca brown	Soft Beige
Beechwood/Soft Beige	Sandstone beige	Charcoal	Espressobrown/Soft Beige	Beechwood	Mocca brown	Soft Beige
Soft Beige	Sandstone beige	Charcoal	Anthracite/Soft Beige	Soft Beige	Mocca brown	Soft Beige
Beechwood/Soft Beige	Sandstone beige	Charcoal	Anthracite/Soft Beige	Beechwood	Mocca brown	Soft Beige
Offblack	Anthracite	Charcoal	Anthracite/Anthracite	Offblack	Offblack	Quartz
Soft Beige/Offblack	Anthracite	Charcoal	Anthracite/Anthracite	Soft Beige	Offblack	Soft Beige
Beechwood/Offblack	Anthracite	Charcoal	Anthracite/Anthracite	Beechwood	Offblack	Quartz
Offblack/Ceramic Light	Anthracite	Charcoal	Anthracite/Anthracite	Offblack	Offblack	Quartz



Leather-clad steering wheel, Charcoal with Silk Metal inlay



Leather-clad steering wheel, Charcoal/Soft Beige with Silk Metal inlay



Leather-clad gear knob, Charcoal, Geartronic and Powershift



Charcoal



Shimmer Graphite

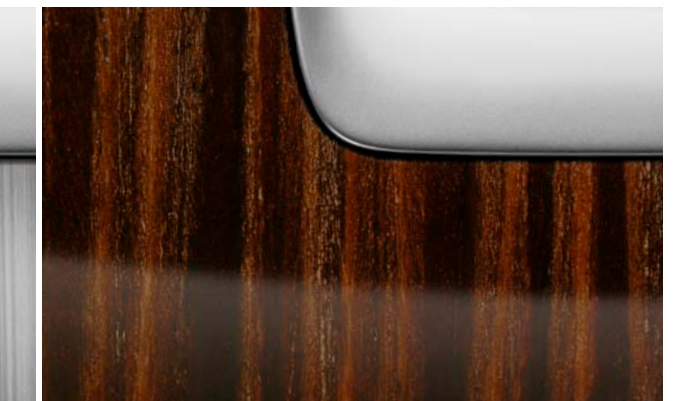

Urbane Wood

Find your next interior at
www.volvocars.com.au



Merchandise Watch



Leather, Offblack in Anthracite Black interior, K101, Shimmer Graphite Aluminium decor inlays



Leather, Beechwood/Offblack in Anthracite Black interior, K103, Charcoal decor inlays



Leather, Soft Beige in Sandstone Beige interior with Espresso IP-top, K11B, Urbane Wood decor inlays



Leather, Beechwood/Soft Beige in Sandstone Beige interior with Offblack IP-top, K113, Shimmer Graphite Aluminium decor inlays



Leather, Soft Beige/Offblack in Anthracite Black interior, K102, Urbane Wood decor inlays



Leather, Soft Beige in Sandstone Beige interior with Offblack IP-top, K112, Urbane Wood decor inlays



Leather, Beechwood/Soft Beige in Sandstone Beige interior with Espresso IP-top, K11C, Shimmer Graphite Aluminium decor inlays

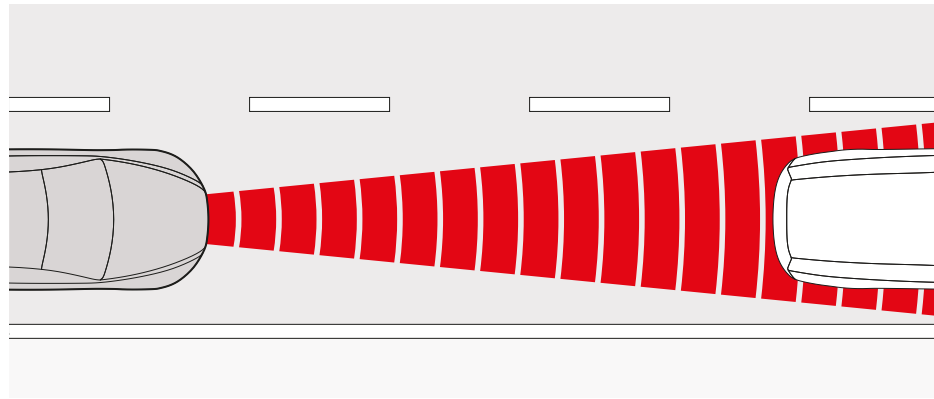

Adaptive Cruise Control (at all speeds)

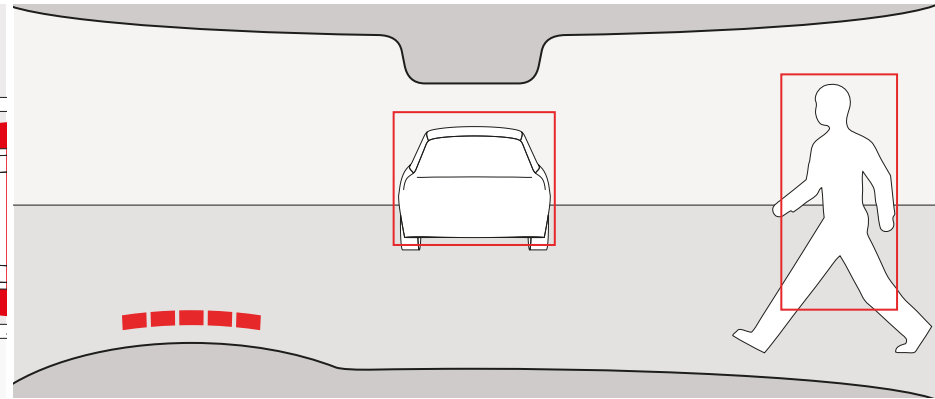

Collision Warning with Full Auto Brake and Pedestrian Detection

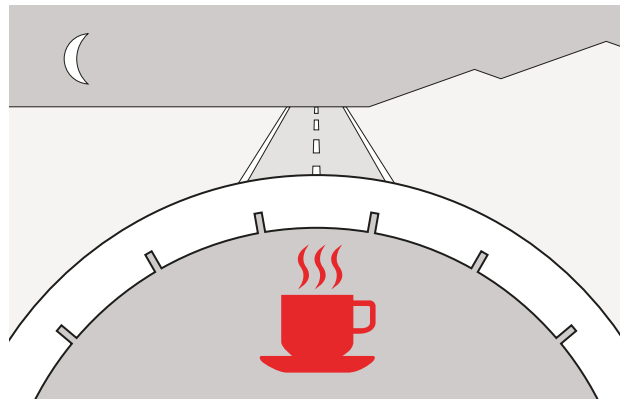

Driver Alert Control (DAC)

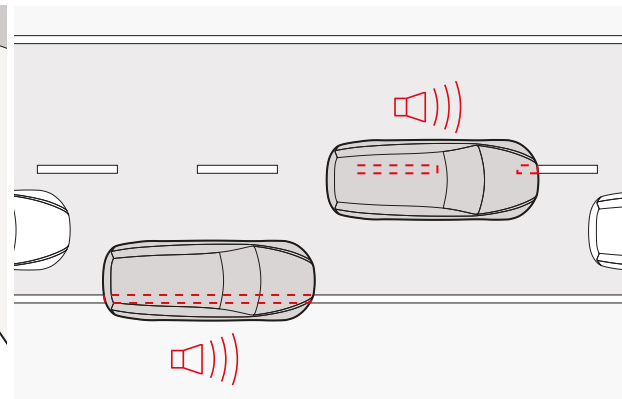

Lane Departure Warning (LDW)

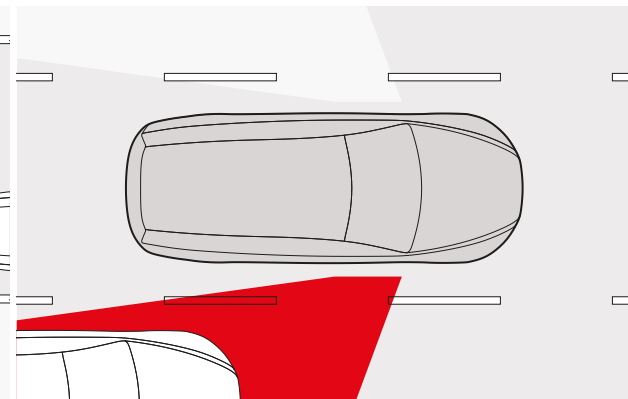

Blind Spot Information System (BLIS)

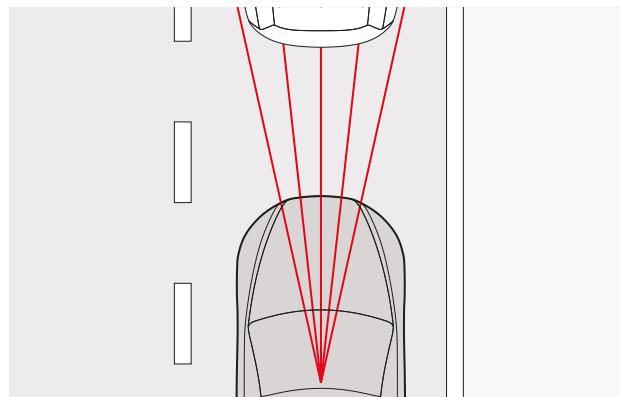

City Safety

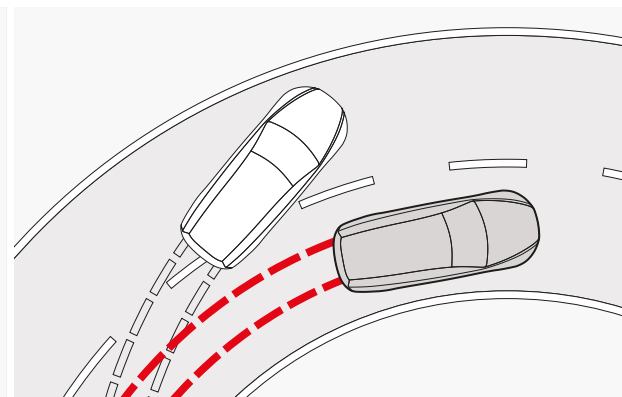

Dynamic Stability and Traction Control (DSTC) with Advanced Stability Control, Corner Traction Control and Sports Mode

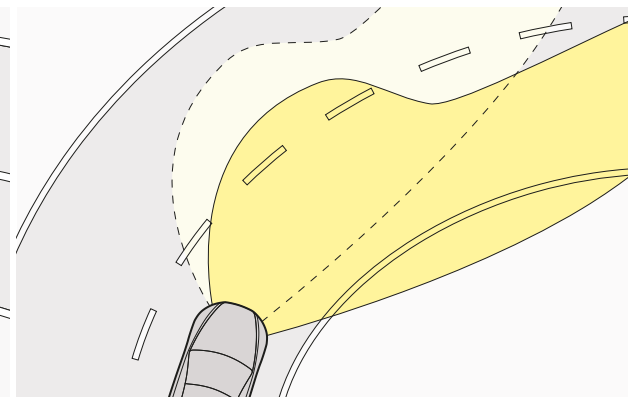

Active Bending Lights (ABL)

Safety

SAFETY Preventive

Adaptive Cruise Control (at all speeds)

Helping the driver to keep a safe distance from vehicles in front at all speeds up to 200 km/h, this third-generation ACC is a supportive partner for a more relaxed driving experience on any journey. In slow-moving city traffic, the ACC stop and go function automatically adapts your speed to the vehicle in front. From standstill, a press of a button or the accelerator is all it takes to make your car smoothly tail the vehicle in front. At speeds over 30 km/h, just select the desired speed and the minimum time gap to the vehicle in front. When the radar sensor detects a slower vehicle in front, the speed automatically adapts to that vehicle. And when the road is clear, the car resumes the selected speed. If ACC is disengaged and a vehicle in front comes too close, the distance alert function activates a warning light in the lower section of the windscreen to help you keep the proper distance.

Collision Warning with Full Auto Brake and Pedestrian Detection

Statistics show that in 50% of the rear end collisions the driver at fault doesn't brake at all. Active at all speeds above 4 km/h, this third-generation collision avoidance technology can warn you if you're too close to a vehicle in front or if there are pedestrians in your path. If you don't react and a collision is imminent, full auto-braking is engaged to help you avoid or mitigate an impact. Within a range of 150 metres, a radar sensor behind the grille and a digital camera behind the windscreen continuously monitor the distance to the vehicle in front of you. During daylight at speeds up to 35 km/h it can also detect standing or moving pedestrians. If a pedestrian unexpectedly steps out in front of your car or if a vehicle suddenly brakes (or is stationary) and Collision Warning senses that a collision is likely to happen, it will alert you to act with a flashing red warning light on the windscreen along with an audible alarm. Moreover, this technology supports driver-initiated braking by pre-charging the brakes to quickly prepare for panic braking and help reduce the reaction time. If you don't react to the warning and a collision is imminent, the car immediately brakes with full braking force.

Driver Alert Control (DAC)

Up to 90% of all traffic accidents are caused by driver distraction. Driver Alert Control is a unique technology that can help alert a tired or distracted driver at speeds over 65 km/h. Using signals from a digital camera to monitor the road ahead along with data from steering wheel movements, DAC can compare erratic behaviour to your normal driving style. A level indicator helps you keep an eye on your alertness status. If DAC detects that your driving behaviour shows signs of drowsiness or distraction, you receive an audible warning. At the same time, a message is displayed on the instrument panel suggesting it might be time for a break.

Lane Departure Warning (LDW)

At speeds over 65 km/h, Lane Departure Warning can help prevent single-vehicle road departures as well as collisions caused by temporary distraction. This function uses a digital camera to register the lane markings and help monitor the car's position on the road. If you weave out of your lane, LDW will alert you with an audible signal. If you intentionally cross a lane marker using the direction indicators, LDW is not activated.

Blind Spot Information System (BLIS)

BLIS uses rear-facing cameras installed in the door mirrors to keep a lookout on either side of the car. As a vehicle enters your blind spot, this function can alert you with a lamp built into the front door post – left and right. Together with the door mirrors, this helps you assess the feasibility of a lane change. BLIS is activated once the car exceeds 10 km/h and reacts to almost any type of vehicle from a motorcycle upwards, day or night.

City Safety

City Safety collision avoidance technology is a Volvo world first standard feature for safer urban driving. At speeds up to 30 km/h, this laser-based technology can sense if a vehicle within 6–8 metres ahead of you is stationary or is moving more slowly. If City

Safety senses an impending collision, the brakes are pre-charged to act faster on your response. And if you don't brake, City Safety automatically applies the brakes and switches off the throttle to help mitigate the effects of a collision. If the difference in speed between your car and the vehicle in front is 15 km/h or less, City Safety can even help you avoid a collision. City Safety is activated when you start the car.

Dynamic Stability and Traction Control (DSTC) with Advanced Stability Control, Corner Traction Control and Sports Mode

By helping to prevent fishtails and spinouts, stability control technology like DSTC has been described as one of the most vital safety advances of the past decade. And with the advanced features in this Volvo, it will probably also be perceived as one of the most important fun-to-drive innovations. At the core of DSTC, sensors register the car's direction and roll rate. The system compares these with steering wheel movements as well as the actual rotation of the car's wheels. DSTC is able to detect a potential skid and help counteract one by reducing the engine's power output or braking on one or more wheels. It also prevents locking wheels caused by engine brake.

The new Advanced Stability Control function features a roll rate gyroscope and acceleration sensor to detect slowly built up skids at an early stage and compensate for them with greater precision. As driver, you'll experience this as added stability in dynamic driving where the car is exposed to high lateral forces. Corner Traction Control by torque vectoring balances the torque between the front wheels during acceleration while cornering – the torque is being distributed from a spinning inner wheel to reduce understeer and increase traction. This enhances stability when cornering at higher speeds and makes the car even more dynamic – as when you turn onto a main road to catch up with the traffic flow. And when you're in the mood for a more sporty drive, why not select the Sports Mode? It shuts off the spin regulation and allows more rear skidding and more fun.

Active Bending Lights (ABL)

Compared to conventional halogen headlamps, Active Bending Lights use Dual Xenon technology to expand your vision range by about 230%. This means you'll be helped to gain a further 45 metres more for braking. And using motorised lamps that turn up to 15 degrees in either direction, this technology gives a 90% boost to your vision round bends at night. You can enjoy highly effective low-beam illumination on narrow, winding roads and extremely powerful full beams on the motorway. A sensor disengages the adaptive function during daylight. Independent of the load, these headlights self-adjust to maintain the correct angle to the road – even during hard acceleration or braking.

Intelligent Driver Information System (IDIS)

To help avoid distractions during critical driving situations, IDIS constantly analyses your driving and will delay secondary information from the car or one of its on-board systems when it detects intense steering, braking or acceleration. As soon as things calm down, the phone call or the delayed information is presented. IDIS can be set up to let phone calls through in all driving situations.

Anti-locking brakes with Hydraulic Brake Assist (HBA) and Ready Alert Brakes (RAB)

Generously dimensioned anti-locking disc brakes and optimised hydraulics help to ensure a short stopping distance in all situations. Furthermore, they withstand tough use without fading. Hydraulic Brake Assist helps you use your brakes to the full in an emergency, while Ready Alert Brakes anticipate severe braking and prepare for it by moving the brake pads closer to the discs. Fading Brake Support automatically compensates for the higher pedal forces required after long periods of heavy braking. Electronic Brake Distribution distributes the braking effect between the front and rear wheels to achieve optimal results according to load and driving conditions.



Volvo's interactive safety technologies



Whiplash Protection System (WHIPS)



Restraint technologies

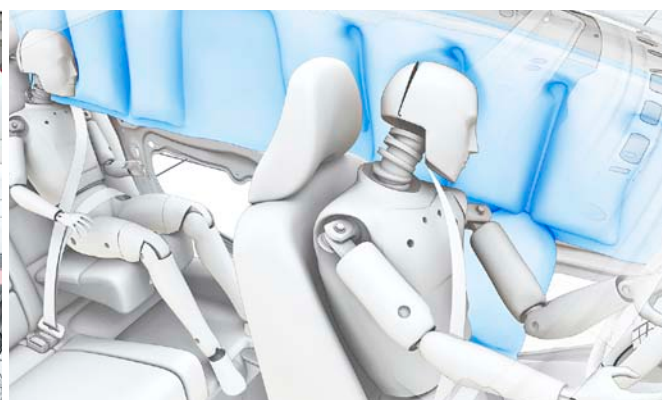

Inflatable Curtain (IC)

SAFETY Protective

Volvo's interactive safety technologies

In a Volvo, safety is about interaction. Because it's not the number of safety features that determines how safe a car is, it's how well they seamlessly interact to help protect the occupants in the event of a collision.

IN A **FRONTAL COLLISION** the patented frontal structure will yield to help absorb and disperse crash energy. The compact powertrain is designed to help optimise deformation. Inside the car, safety belts interact with the collapsible steering column and dual-stage airbags to help keep the occupants out of harm's way. Pre-prepared restraints – a unique Volvo technology – helps optimise the various restraint systems for the expected crash force.

IN A **ROLLOVER** a gyroscope activates Volvo's Roll-Over Protection System (ROPS). The safety belt pre-tensioners deploy to help keep occupants more securely restrained, and the Inflatable Curtain (IC) provides extra head protection. In addition the safety cage is reinforced to help keep the passenger compartment intact.

IN A **SIDE IMPACT** Volvo's unique Side Impact Protection System (SIPS) helps distribute the crash forces across the car's body, away from the occupants. The side airbags in the front seats help protect the chest and hip, while the Inflatable Curtain (IC) adds head protection.

IN A **REAR IMPACT** the rear deformation zones will help absorb crash energy. The fuel tank is designed to remain well protected in front of the rear axle. The head restraints help protect the neck and spine, and Volvo's unique Whiplash Protection System (WHIPS) cradles the front seat occupants in a controlled manner to help prevent whiplash injuries.

Restraint technologies

In a collision, Volvo's restraint technologies interact to help reduce the impact. The **safety belts with pre-tensioners** activate within a few thousandths of a second in the event of a collision or rollover and tighten the belt to help keep the occupants securely restrained. The front seat safety belts then release a little so that the driver and passenger are cushioned by the airbags in a controlled manner. Helping to optimise protection, the **dual-stage airbags** adapt the level of inflation depending on the force of the collision. The driver's airbag also interacts with the deformation of the collapsible steering column.

Side airbags in the front seats help reduce the risk of serious injuries in a side collision. In a collision or rollover, the **Inflatable Curtain (IC)** helps protect the heads of both front and rear outboard occupants. It also stays inflated for several seconds to provide prolonged protection for subsequent impacts.

Whiplash Protection System (WHIPS)

Integrated in the front seats, Volvo's WHIPS cradles the occupant to help reduce the risk of whiplash injury (one of the most common types of traffic injury and often the result of a low-speed rear impact collision). The function is activated by a collision of sufficient force from behind. Independent research has shown that WHIPS is one of the most effective systems in the world and can reduce the risk of long-term injuries by 50%.

Pre-prepared restraints

The restraint technologies of your Volvo are designed to help provide maximum protection while minimising strain on the occupants. Using new technology including a windscreen laser-sensor, this standard safety feature continuously monitors objects in front of the car at all speeds. This makes it possible to prepare and adapt the safety belts and airbags for an expected crash force and thus help optimise protection in a low or mid-severe frontal collision.

Side Impact Protection System (SIPS)

SIPS is a safety system unique to Volvo that has been developed to help protect the occupants in the event of a side collision. The steel framework of the car – including the front seats – is designed and reinforced to help displace the impact of a side collision away from the occupants to other parts of the car body and

help prevent intrusion into the cabin. The extremely strong side structure contains ultra-high strength steel to help withstand a severe side impact – even with a larger vehicle. The Inflatable Curtain (IC) for all the outboard occupants and the front seat side airbags interact with the SIPS to provide further protection. In the rear seat, the combination of extended IC and Volvo's integrated two-stage booster cushion with progressive safety belt load limiters helps protect children.

Energy-absorbing frontal structure

Volvo's patented frontal structure with its sizeable deformation zones in different kinds of steel will yield to help absorb crash energy. The compact powertrain is designed to help optimise deformation. The unique geometry of the frontal structure and longitudinal steel struts in the doors helps disperse crash energy away from the front to the rear of the car, further reducing the strain on the occupants. A steel cross-member under the dashboard further helps keep the cabin intact.

Protection of unprotected road users

To help reduce the risk of serious injuries to unprotected road users, the front of the vehicle is gently rounded, the headlamps are integrated flush with the body, and the bonnet is energy-absorbing to act as a crumple zone.



Personal Car Communicator (PCC)



Power retractable door mirrors with ground lighting

SAFETY Child safety

Power child safety lock

The power child lock enables you to conveniently lock the rear doors and rear power windows from the driver's seat and prevent them from being opened from the inside.

SAFETY Security

Personal Car Communicator (PCC)

PCC is an advanced remote control that combines keyless drive with two-way communication with your Volvo. Keep the PCC with you and the car unlocks automatically as you pull the door handle. Start the engine by pressing a button on the dash, lock the car by pressing a button in the door handle. Later in the day, if you're wondering whether you've locked the car, PCC can tell you, no matter where you are. On your return to the car – within a radius of 60 to 100 metres – pressing the PCC information button will give you a current report on its lock and alarm status.

360° laminated windows

Laminated glass in all windows turns an attempted smash-and-grab into a time-consuming ordeal. It also enhances sound comfort in the cabin and contributes to UV protection. This option also includes water-repellent glass in the front side windows for improved visibility in wet weather.

Private locking

Private Locking is a function that allows you to keep the luggage and glove compartment locked even when you lend someone your key or Personal Car Communicator. To activate Private Locking, a miniature key incorporated within the remote control is used to lock the glove compartment and tailgate. This stops both compartments – including the hidden storage area under the load compartment floor – from being unlocked with the central locking remote control, but allows the central locking system and ignition to be used as normal.

Lockable floor

To further foil smash-and-grab burglaries, the closed tailgate – simply by means of its design – overlaps and seals the compartment hidden under the cargo floor. To keep this private storage area inaccessible

to other users of the car, e.g. during parking, you can include the tailgate when setting your private locking preferences.

Approach and Home Safe Lighting

Activated with the remote control or Personal Car Communicator, Approach Lighting provides a warm reception on a dark night. It consists of interior and side lights – ground lighting too, if you choose it. Home Safe Lighting is activated with the headlight stalk as you leave the car and it provides a similar courtesy when exiting your car. This feature includes a dipped beam from the headlight to accompany you to your door.

Power retractable door mirrors with ground lighting

At the touch of a button, these door mirrors can be folded flat against the car where they are less likely to get damaged after you've parked. They also fold or unfold automatically every time you lock or unlock the car. The integrated ground lighting is activated with the remote control or with the PCC. Besides enhancing security to and from your car at night, this is also convenient when getting in and out.

Remote-controlled central locking

A touch of a button on the remote locks or unlocks the doors and boot lid. Use the personal settings menu to decide whether the remote unlocks the driver's door first or all the doors together. You can also close or open all the windows (including the sunroof if you have one) and unlock the boot separately.

Automatic door locking

To further enhance your personal security, the doors can be set in the information menu to automatically lock the moment you drive away. Alternatively, you can lock them swiftly from the front seats using the lock button. Lock buttons are also available for the rear seat passengers.

Remote-controlled alarm

The alarm is connected to the doors, bonnet, boot and ignition. It also reacts to movement inside the car or the breaking of a window. A level sensor can be added to deter thieves from jacking up the car and stealing your wheels. And in an emergency situation, the panic button on the remote control or on the PCC allows you to raise the alarm for help.



Ergonomic design

Integrated coat hanger

Allergy-tested upholstery

Adjustable lumbar support

Multiple adjustment possibilities

Front pocket



Power front seats



Electronic Climate Control (ECC)



Power glass sunroof



Front centre armrest, multifunctional



Rear centre armrest



► Sunglass holder

Comfort

COMFORT Seats

Power front seats

Find your perfect driving position with push-button ease. The driver's seat also incorporates a memory function that stores three separate seat and door mirror settings connected to a specific remote control – a feature that's appreciated when the car has several drivers. To facilitate parking, the door mirror on the passenger side tilts automatically when reversing.

Heated seats, front and rear

Adjustable in three settings, heated seats for the driver and front seat passenger add to comfort on those cold mornings. And to enhance comfort for friends in the rear seat, this convenience is also available for the outer rear seat positions.

COMFORT Climate

Electronic Climate Control (ECC)

Electronic Climate Control (ECC) maintains the cabin temperature you choose and can be set independently for the driver and front passenger. Further contributing to your health and comfort, the optional humidity sensor helps ensure that the cabin air has an appropriate level of humidity for the outside climate.

Interior Air Quality System (IAQS)

Volvo's IAQS continuously monitors incoming air and will, if necessary, temporarily close external air vents to shut out carbon monoxide, ground-level ozone and nitrogen dioxide. Meanwhile, an active carbon filter protects the occupants from other harmful gases and unpleasant odours. This helps ensure that the air you breathe in the car is cleaner than the air outside when driving in heavy city traffic and tunnels.

Clean Zone Interior Package (CZIP)

CZIP comprises a series of modifications to further improve the interior atmosphere. Materials are chosen carefully to avoid harmful fumes and surfaces are smooth, so they're easy to clean. On days when it's at least 10°C outside, opening the car by remote triggers a 60-second ventilation cycle. This results in cabin air approved by the Swedish Asthma and Allergy Association.

Power glass sunroof

This makes the interior feel extra light and airy. It opens and closes at the touch of a button. If the sun is too strong, just close the built-in sunshade. The sunroof can also be closed together with the side windows using the central locking remote control.

COMFORT Storage

Front centre armrest, multifunctional

The central aisle of the cabin incorporates several facilities. Two cup holders are concealed by a roll-top cover. There's a handy storage space beneath the armrest, and special recesses for small items. Folding back the upper part of the armrest provides a convenient table for the rear seat passengers. The armrest also features an AUX input and a USB port to connect your MP3 player to the car's audio system.

Rear centre armrest

Folded down, the rear centre armrest gives increased comfort and provides the rear seat passengers with cup holders and smart storage.

► Sunglass holder

Fitted in place of any of the entry handles in the front, this holder keeps your glasses or sunglasses within reach.



Volvo Sensus driver-control interface



Park assist camera, rear



► Front blind view camera



Volvo Navigation System (VNS)



Bluetooth® handsfree system

Tech & Sound

TECH & SOUND Driver's Support

Volvo Sensus driver-control interface

Volvo's new driver-control interface allows you to conveniently explore the hi-tech features of your car and personalise them to suit your needs. All information is displayed on a high resolution 7" screen. A push of the MY CAR button in the centre console gives you access to all system settings such as IDIS, City Safety, ACC, Collision Warning with Full Auto Brake and Pedestrian Detection, Driver Alert System, BLIS, light, door mirrors, climate, central locking and audio.

The 7" screen can also display the VNS navigation system, phone, park assist camera, DVD etc. Everything is conveniently controlled using the ergonomic steering wheel controls – so you can keep your attention on the traffic and your hands on the steering wheel.

Park assist, rear Park assist, front

Activated when you engage reverse gear, rear park assist helps you when reversing into tight spaces. The audio system is turned down and a pulsating sound from the rear loudspeakers becomes a continuous tone as you approach an obstacle. Front park assist performs a similar function at the front of the vehicle – alerting you via the front loudspeakers. The remaining distance is also shown in the centre console colour display.

Park assist camera, rear

To further add to your convenience when reversing, the rear park assist camera helps display what's going on behind your car. The system uses the integrated driver's information screen and a digital camera discretely located over the numberplate. On-screen guiding lines provide extra assistance for smooth parking.

► Front blind view camera

Allowing you to see around corners, this new camera is located in the grille to give you a 180° field of vision for the area in front of your car. Activate the camera with a push of a button and you'll get a split-image view on the 7" integrated driver's information screen. Very convenient in tight exits with limited visibility and while parking.

Rain sensor

Once activated, the rain sensor can start the windscreen wipers as soon as it begins to rain or if water splashes onto the windscreen. For your convenience, it can also automatically adapt the intermittent windscreen wiper function. Its sensitivity can be adjusted via a ring on the wiper stalk.

Automatically dimmed inner rear-view mirror

This is a mirror that automatically adjusts to deflect the headlamp beams of the car behind you. When there's no light to dazzle you, it automatically readjusts to its normal setting. It can be supplemented with an integrated compass.

Power parking brake

The Power Parking Brake (PPB) makes moving off from steep gradients easier. Once depressed, the PPB control lever automatically releases as the car pulls away.

TECH & SOUND Communication

Volvo Navigation System (VNS)

Volvo's GPS-based RTI navigation system is totally integrated with your car. It offers both voice guidance and graphic navigation all the way to your destination. The VNS system utilises the integrated 7" driver's information display and is easily controlled from the steering wheel or a remote – you can keep both hands on the steering wheel and your attention on traffic. In some areas you can also set your destination using voice control.

Extremely swift and precise, the VNS features a hard disk drive containing maps for the VNS features a hard disk drive containing maps for Australia and New Zealand.

Bluetooth® handsfree system

Bluetooth® technology enables a mobile phone to be connected wirelessly to the infotainment system in your Volvo. Once configured for a mobile phone, the system automatically recognises your phone as you enter the car. And as you climb in and out of the car, the system automatically allows you to switch freely from the phone to the handsfree system and back again.

The High Performance Multi Media and Premium Sound Multi Media audio systems include an integrated Bluetooth® handsfree system, allowing you to conveniently operate your phone using the buttons on the steering wheel or the centre console keypad. Phone information is shown in the centre console Multi Media display. And if you choose RTI navigation system, you can make your calls using voice control. What's more, you can stream music from your mobile phone or a media player and listen to it through the car's audio system.

Available as an accessory for the Performance audio system.

The Bluetooth word mark and logos are owned by the Bluetooth SIG, Inc. and any use of such marks by Volvo Car Corporation is under licence. Other trademarks and trade names are those of their respective owners.

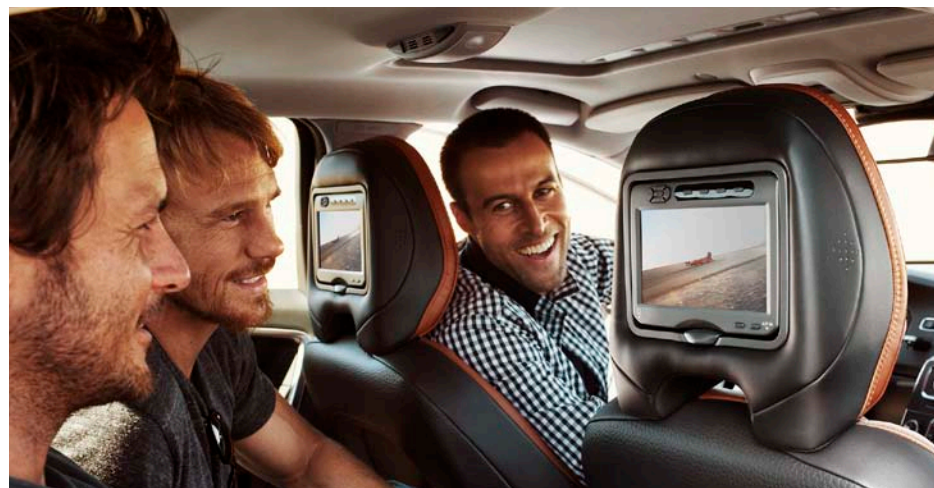

► Rear Seat Entertainment (RSE) with dual DVD players



7" Multi Media screen

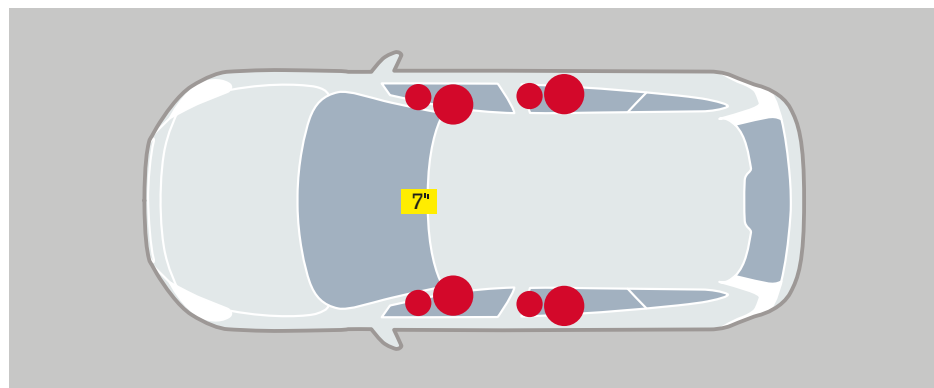

High Performance Multi Media system

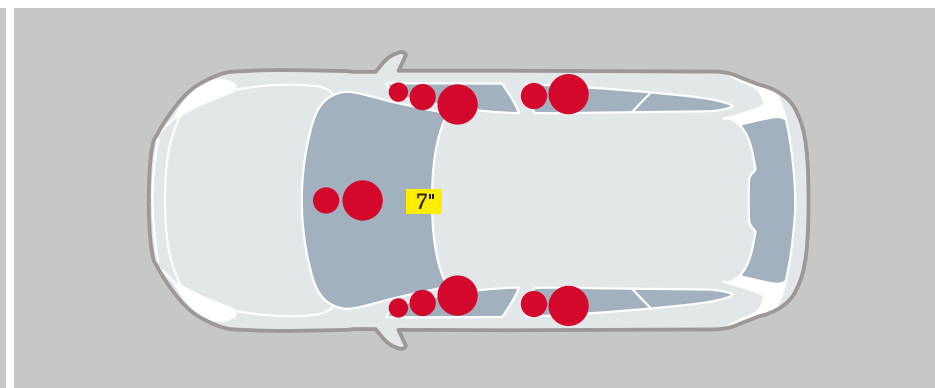

Premium Sound Multi Media system

AUDIO/MULTI MEDIA SYSTEM

	Dual tuners	CD player	CD/DVD player	AUX input	USB/iPod® input	Audio streaming	Amplifier W	Loudspeakers	Dolby® Pro Logic® II Surround Sound	Rear seat audio console	Bluetooth hands-free	Steering wheel controls	7" Multi Media screen	Rear Seat Entertainment (RSE)	VNS navigation	Park assist camera
HIGH PERFORMANCE MULTI MEDIA	●		●	●	●	●	4x40 W	8		○	●	●	●	►	○	○
PREMIUM SOUND MULTI MEDIA	●		●	●	●	●	5x130 W	12	●	○	●	●	●	►	○	○

●=INCLUDED ○=OPTIONAL ►=ACCESSORY

TECH & SOUND Audio

High Performance Multi Media system

Above the crisp sound reproduction of the High Performance audio components, this audio level provides a full 7" integrated Multi Media colour screen. This transforms your Volvo to a complete platform for the latest in in-car entertainment, communication and navigation technology. For example, you can watch DVD films broadcasts when the car is stationary. Bluetooth® and USB/iPod® connectivity further adds to the versatility of this system.

Premium Sound Multi Media system

We designed this top-of-the line audio and infotainment system to give you a superior listening and communication experience. This 5x130 W system features twelve high-fidelity loudspeakers and MultEQ sound processor technology by Audyssey Laboratories that optimises the sound reproduction for the interior acoustics. Dolby® Pro Logic® II surround sound helps tailor a well-balanced audio experience for each occupant. And to give you access to advanced in-car entertainment, communication and navigation technology, this system also connects with most media formats and players and features an integrated 7" Multi Media screen. For example, you can watch DVD films or terrestrial TV broadcasts when the car is stationary while enjoying a full-size aural experience.

Dolby, Pro Logic and the double-D symbol are registered trademarks of Dolby Laboratories.

Premium Sound loudspeakers

The twelve high-end loudspeakers in the Premium Sound system are powered by a 5x130 W digital amplifier. There are three separate drivers – woofer, midrange and tweeter – in each front door. In the rear doors there is a similar set-up. Each speaker has its own crossover filter to harmonise with the others. The latest generation Dolby® Pro Logic® II surround sound uses the centre loudspeakers (woofer and tweeter) and a sound processor to recreate authentic sound with a strong sense of presence for everyone in the car. The digital class D amplifier features new technology to provide extremely high efficiency, enabling it to generate the most audio power from the least amount of current.

MP3 compatibility

There are a number of ways in which to enjoy MP3 music files in your Volvo. The CD player is compatible with a variety of audio media formats. If you'd like to connect your personal MP3 player to the audio system, there's a standard auxiliary audio input in the front centre armrest. Volume is conveniently controlled from the steering wheel, centre console or rear seat audio console. There's also a USB port that allows you to fully integrate your iPod®, MP3 player or USB device with the audio system. Playlists, songs and artists are clearly displayed in the centre console, while your player is charged at the same time.

iPod is a trademark of Apple Computer Inc.

Audio streaming

The integrated Bluetooth® technology allows wireless communication and streaming of music files. Simply connect your Bluetooth® compatible mobile phone to your audio system and enjoy the music files stored in your phone. Songs and artists can be shown in the integrated colour screen.

TECH & SOUND Entertainment

► Rear Seat Entertainment (RSE) with dual DVD players

For more fun on long journeys, this easy-to-use system will entertain for hours. Dual DVD players and dual 7" screens are smartly integrated in the front head restraints. Each DVD player is conveniently operated by a rear seat passenger. The passengers can see the same movie or play the same game on both screens, or choose to view a film on one screen and play games on the other. Sound is provided via the car's audio system or wireless headphones.

► = Accessory (can be fitted as factory option, or after you've purchased your car).

Volvo V60

ACCESSORIES



EXTERIOR STYLING:

- Front and rear skid plate.
- Side scuff plates.
- Front deco frames.
- Single/double end pipes.
- 18" Freja Wheels.

SPONTANEITY HAPPENS.

Some people see a sportswagon, others see a work of modern art. In either case, there's room for improvisation here. The versatility of your Volvo V60 makes our outstanding cargo management accessories a must have for many people. The accessories you choose for your V60 need not follow any preconceptions about what a sportswagon should be. When we designed the sleek V60, we left all preconceptions behind. That way, you can define it for yourself.



DIRT COVER LUGGAGE:

A practical load compartment cover made of durable and dirt-resistant vinyl that covers the floor and side walls of the load compartment plus the rear of the rear seats.



LOAD CARRIERS WITH RAILS:

A specially designed transport system for loads on the roof. The load carriers are two swept aluminum profiles and feet with fully covering black plastic covers.

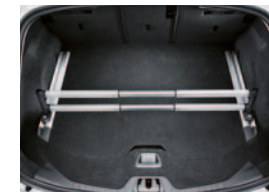

LOAD ORGANISER INCLUDING RAILS:

A unique load organiser system which is easy to install in the load compartment and which helps keep the load in order whilst travelling.



LUGGAGE MAT TEXTILE:

Reversible and waterproof load compartment mat with textile on one side and plastic on the other. The mat has an appealing design with a stitched edge all around.



NET POCKET KIT:

A kit with two mesh pockets for the side panel in the cargo compartment. The kit offers simple and practical storage in the cargo compartment.



SUNSHADES:

Easily attached to the rear door windows and rear window, these reduce the heat and glare of direct sunlight. Simple to remove when they're not needed.



PARK ASSIST CAMERA, FRONT BLIND VIEW:

Allowing you to see around corners, this new camera is located in the grille to give you a 180° field of vision for the area in front of your car. Activate the camera with a push of a button and you'll get a split-image view on the 7" integrated driver's information screen. Very convenient in tight exits with limited visibility and while parking. Only available in combination with High Performance Multi Media or Premium Sound Multi Media.



DETACHABLE TOWBAR:

Designed specifically for your Volvo, the locally sourced towbar meets Australian standards and requirements. Easy to remove and fit when required.



REAR SEAT ENTERTAINMENT (RSE):

For more fun on long journeys, this easy-to-use system will entertain for hours. There are dual DVD players and dual 7-inch screens smartly integrated in the front head restraints. Each DVD player is conveniently operated by a rear seat passenger. The passengers can see the same movie or play the same game on both screens, or choose to view a film on one screen and play games on the other. Sound is provided via the car's audio system or wireless headphones.



PORTABLE NAVIGATION GARMIN:

The Garmin nüvi® is sleek and stylish, yet loaded with really smart navigation features and convenient functions. Enjoy the bright multi-touch display, the voice-activated navigation, 3D views, lane assist and many other great features. With the Garmin nüvi, you get an easy-to-use, intelligent portable navigation of award-winning design. The Garmin nüvi comes preloaded with full-coverage Australian and New Zealand mapping and it's the perfect choice for you who want to make the most of your Volvo driving experience. nüvi is a trademark of Garmin Ltd.

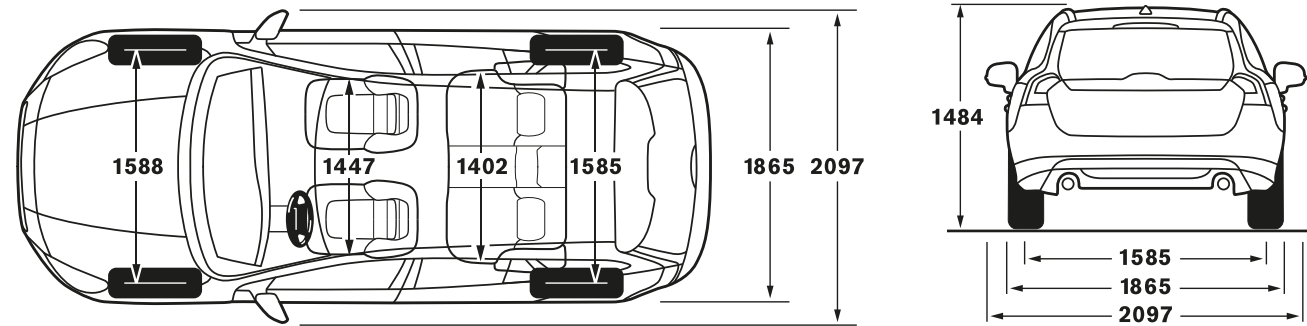
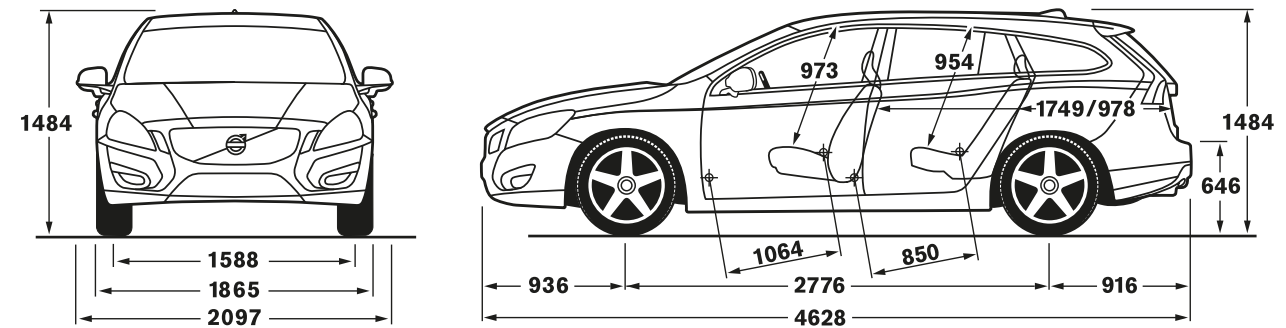

	T6 AWD	T5	T4	D3
Engine type:	3.0L I6 petrol twin-scroll turbo	2.0L I4 petrol turbo	1.6L I4 petrol turbo	2.0L I5 common-rail turbodiesel
Transmission:	Six-speed Geartronic	Six-speed Powershift	Six-speed Powershift	Six-speed Geartronic
Fuel consumption, litres/100 km, mixed cycle, auto:	10.3	8.7	7.8	6.0
CO ₂ , g/km, auto:	247	205	181	160
Max. power output, kW at rpm:	224 at 5600	177 at 5500	132 at 5700	120 at 3500
Max. torque, Nm at rpm:	440/2100–4200	320/1800–5000	240/1600–5000	400/1500–2850
Acceleration, 0–100 km/h in sec, auto:	6.2	7.7	9.2	9.4
Top speed, km/h, auto:	250	230	220	215
Fuel tank, litres:	67.5	67.5	67.5	67.5
Environmental classification:	Euro 5 (2011)	Euro 5 (2011)	Euro 5 (2011)	Euro 5 (2011)

All technical data may be subject to change. Please talk to your Volvo dealer for the latest information.

Performance

PERFORMANCE Chassis/Steering

Chassis

Volvo's chassis engineers have spent thousands of hours on all kinds of roads to create a chassis that satisfies even the most demanding driver. Every single detail of the chassis is optimally tuned for sporty and well-balanced handling with a high level of comfort. For you as driver, advanced multi-link rear and McPherson spring strut front suspensions mounted on a rigid body with a low centre of gravity translate into a feeling of being in command and in safe control. The front and rear suspensions also interact to provide stable braking and crisp steering. In a curve, the rear wheels have a slight steering facility for added stability and steering response.

Continuously Controlled Chassis Concept (Four-C)

The Four-C active chassis provides a choice of three distinctive driving modes – Comfort, Sport or Advanced. Whichever you choose, this technology monitors the car, road and driver 500 times per second, simultaneously adjusting each shock absorber to maintain optimal handling. At the heart of Four-C is Volvo's semi-active suspension with continuously controlled Monroe-Öhlins shock absorbers. Furthermore, Four-C interacts with the DSTC system, engine, brakes and steering to promote your chosen handling style.

Comfort This chassis mode isolates the car's occupants from irregularities in the road surface. This setting prioritises flexible damping for smooth and gentle body movement and exceptional comfort. It's ideal for slippery or uneven roads.

Sport For a sportier experience, this setting prioritises slightly stiffer damping and acts faster. This results in more decisive body movement, precise handling and good ride comfort. Perfect for active driving.

Advanced This is the high performance mode. This setting stiffens the dampers for maximum road contact – directly communicating the road surface to the driver. Prioritising immediate feedback rather than comfort, the advanced setting increases the range of driving dynamics.

Speed-dependent steering

Speed-dependent and progressive power steering uses sophisticated, speed-sensitive technology to regulate the amount of power assistance a driver needs. At motorway speeds, steering is firmer and more immediate. When parking or in slow-moving traffic, steering is light and effortless. There's a choice of three settings allowing you to choose a suitable level of road feel or steering sensitivity.

PERFORMANCE Transmission

Six-speed Geartronic automatic transmission

For the best of two worlds, there's the six-speed Geartronic – a responsive automatic that's ideal for relaxed driving, tough conditions or towing. This also allows manual gear shifting so you can maintain a lower gear to bring up the revs or for the added assistance of engine braking. In the T6, this automatic also feature a sports mode for more active driving – it shifts more responsively to your throttle movements.

Six-speed Powershift transmission

Featuring Powershift dual-clutch technology, this six-speed automatic can reduce fuel consumption by 8% compared to a conventional automatic. Gears are shifted instantaneously and torque is delivered without interruption. And if you want, you can also shift gears manually.

All-wheel drive with Instant Traction™

The advanced Haldex AWD technology with Instant Traction™ helps increase driving stability and traction on all road surfaces. It has an electronic management system that constantly monitors the speed of the wheels, the throttle, engine torque, engine speed and the brakes. As driving conditions change, wheels with the best grip get the most power. When a tyre loses traction, power is reduced to that wheel and instantly transferred to the more sure-footed wheels.

Brake energy regeneration

To further optimise fuel efficiency and performance in all driving conditions, all engines feature Volvo's intelligent brake kinetic energy regeneration. As soon as you brake or release the accelerator while a gear is engaged, the alternator harnesses the car's kinetic energy and feeds it into the battery to reduce fuel consumption by an extra 2–3%. And when you accelerate, the alternator decouples to free the engine for maximum performance when you need it.

Care by Volvo.

Make the most of your Volvo experience.

It's built into your Volvo – the care for you and your loved ones. And it's also there for you during all the time you own it. Care by Volvo is a family of services to help you make the most of your Volvo experience. These services reflect a set of values shared by the entire Volvo organisation, values that make your satisfaction and safety a top priority. Whatever your needs during your Volvo ownership, there is a smooth and considerate solution.

Volvo Car Insurance.

As with our cars, we want to ensure our Volvo Car Insurance lives up to the expectations of Volvo owners in every way. It is what you would expect from Volvo.

Benefits include:

- New car replacement*
- Genuine Volvo Parts*
- Choice of Repairer
- Maximum No Claim Bonus protected
- Rental car following theft
- Attached Trailer and Caravan Cover
- Cover for authorised Volvo loaned service vehicles

Options available:

- Removal of excess for windscreen claims;
- Rental or loan car following an accident;
- Agreed Value;

*Subject to availability

This is a summary of the benefits available under Volvo Car Insurance. We do not advise you whether the insurance is appropriate for your personal objectives, financial situation or needs. To decide if it is appropriate for you, ask for a copy of the Policy Document and Product Disclosure Statement listing the full benefits and limits to cover. Please see your Volvo Dealer for a quotation.

This insurance is issued by Allianz Australia Insurance Limited AFS Licence No. 234708, ABN 15 000 122 850 (Allianz). In arranging this insurance Marsh Pty Ltd, AFS Licence No. 238983, ABN 86 004 651 512 and authorised dealers act as agents of Allianz and not as your agent.

Volvo Car Financial services.

Choosing the right vehicle and finding the right financial package has been made easier with Volvo Car Financial services. As you would expect, we have a flexible range of financial products, tailored to make your life easier.

Whether you're a private purchaser or you're choosing a Volvo for business, we have a wide range of flexible finance and lease products. After all, the right car needs the right financial package to complement your lifestyle.

Please contact your local Volvo dealer for more information on the individual finance products available, you can find your local dealer at: www.volvocars.com.au

Important Notice:

1. Volvo Car Financial Services is a registered business name of Macquarie Leasing Pty Limited ABN 38 002 674 982 (ML) who is the financier of these products. ML is not an authorised deposit-taking institution for the purposes of the Banking Act 1959 (Cth), and ML's obligations do not represent deposits or other liabilities of Macquarie Bank Limited ABN 46 008 583 542. Macquarie Bank Limited does not guarantee or otherwise provide assurance in respect of the obligations of ML.

Volvo New Car Warranty.

Every new Volvo is covered by our comprehensive three-year warranty giving you peace of mind for a full three years and unlimited kilometers. Please contact your local Volvo dealer for full new car warranty terms and conditions.

Volvo Extended Warranty.

Volvo Car Extended Warranty is designed for additional peace of mind. Volvo Car Australia offers an additional 12 or 24 month's extended warranty after the expiry of the original 3 year new car warranty (must be purchased within new car warranty period).

Please contact your local Volvo dealer for full Extended Warranty terms and conditions.

Volvo Roadside Assistance.

Volvo Roadside Assistance is not just there to get you going again if your car breaks down. It's also there for more human mistakes like running out of fuel or locking your keys inside the car. In the unlikely event that your Volvo encounters a mechanical breakdown, you can benefit as a Volvo owner from our complementary Volvo Roadside Assistance Program, which gives you total peace of mind 24 hours a day, every day, Australia-wide.

The Volvo Roadside Assistance program is valid for the length of the manufacturer warranty or Extended Volvo Roadside Assistance Program.

VOLVO SERVICE 2.0*

FREE SOFTWARE UPDATES ARE JUST THE BEGINNING

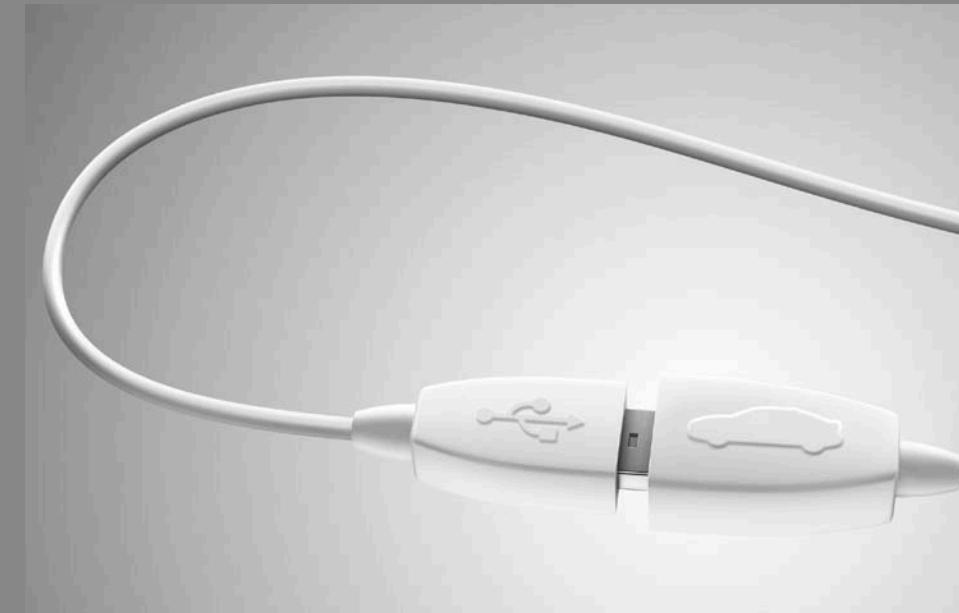

In today's cars there are many computers and just like with desktop computers, their software should be updated from time to time.

So, in the interest of providing the best service possible, we've developed Volvo Service 2.0, where your Volvo software is updated free of charge as part of a routine Volvo scheduled service. This means that your Volvo systems (which are unique to your vehicle) will always be optimised for top performance.

Free software updates are just the tip of the iceberg. Volvo Service 2.0 ensures you'll always have your vehicle serviced by a Volvo-certified technician, using Volvo methods and Volvo Genuine parts.

You'll be offered 12 months free roadside assistance and a complimentary exterior wash. In fact, we'll even provide you access to an alternative transport solution while your vehicle is being serviced.

For more information on the many benefits of Volvo Service 2.0, just call us on **1800 786 586**, go to <http://www.volvocars.com.au> or visit your nearest Volvo dealer.

VOLVO SERVICE 2.0* ALSO INCLUDES:



VOLVO ASSISTANCE:

For peace of mind, every Volvo service comes with a complimentary roadside assistance package, covering you for 12 whole months.



ALTERNATIVE TRANSPORT:

It's not easy being without a car, that's why Volvo Service 2.0 offers you alternative transport solutions while your vehicle is being serviced.



CONDITION CHECK:

We will perform a health check of your Volvo and provide you with a check list, with a focus on safety features, while we are servicing your Volvo.



VOLVO-CERTIFIED TECHNICIAN:

Using only technicians trained by Volvo, to work on Volvo cars, a Volvo Service 2.0 service ensures your Volvo is placed in the most qualified hands.



CAR WASH:

After we've finished fine tuning your car on the inside, Volvo Service 2.0 will fine tune it on the outside thanks to a complimentary exterior car wash.



DEALER FOLLOW-UP:

With Volvo Service 2.0, your service doesn't end when you drive out of the centre. We'll also call you a couple of days afterwards to check things are still running smoothly.

* Volvo Service 2.0 and all its benefits as set out herein, including the offer of free software updates, may only be accessed from authorised Volvo dealers at the time of your vehicle's scheduled servicing and is available for a period of six years from the date of a vehicle's first registration.

86901901

TECHNICAL SPECIFICATIONS

V60	T4	T5	T5 R-Design	D3	T6	T6 R-Design
DRIVE-AWAY PRICING*						
Please contact your local Volvo dealer for drive-away pricing, or call 1800 7 VOLVO for referral to your nearest Volvo dealer.						
ENGINE / PERFORMANCE						
Engine	Four cylinder, 16 valve DOHC Gasoline Turbocharged Direct Injection (GTD) petrol engine	Four cylinder, 16 valve DOHC Gasoline Turbocharged Direct Injection (GTD) petrol engine	Five-cylinder, 20 valve DOHC turbocharged diesel engine		Six-cylinder, 24 valve DOHC turbocharged petrol engine	
Location	Front transverse	Front transverse	Front transverse		Front transverse	
Drive	Front Wheel Drive	Front Wheel Drive	Front Wheel Drive		All-Wheel Drive	
Displacement	1595cc	1999cc	1984cc		2953cc	
Power output	132kW at 5700rpm	177kW at 5500rpm	120kW at 3500rpm		224kW at 5600rpm	
Torque	240Nm at 1600 - 5000rpm	320Nm at 1800 - 5000rpm	400Nm at 1500 - 2750rpm		440Nm at 2100 - 4200rpm	
Acceleration 0 -100km/h	9.2 seconds	7.7 seconds	9.4 seconds		6.2 seconds	
Top speed	230 km/h	230 km/h	215 km/h		250 km/h	
Fuel economy (combined) l/100km	7.8	8.7	6.0		10.3	
CO ₂ g/km	181	205	160		247	
TRANSMISSION						
Automatic	6 speed Powershift with Neutral Control function		6 speed Adaptive Geartronic with Neutral Control and Sports mode			
STEERING						
System	Electro-Hydraulic Power Assisted Steering (EHPAS)					
Turns to lock	2.58					
Turning circle	11.9 metres					
Speed sensitive power steering	\$800					
CHASSIS						
	McPherson strut front suspension with multi-link independent rear suspension					
	Anti-dive anti-lift function					
	Anti-roll bars front and rear					
Touring Chassis	▲	▲	—	▲	▲	—
Dynamic Chassis	•	•	—	•	•	—
Sports Chassis	—	—	•	—	—	•
Four-C Chassis (not with Nivomat)	\$4,175	\$4,175	—	\$4,175	\$4,175	—
Nivomat self levelling suspension	\$1,350	\$1,350	—	\$1,350	\$1,350	—
WEIGHT						
	1553kg	1599kg	1626kg		1747kg	
FUEL TANK						
Capacity	67.5 litres					
LOAD CAPACITY						
Maximum trailer weight (braked)	1600kg	1800kg	1600kg		2000kg	

V60	T4	T5	T5 R-Design	D3	T6	T6 R-Design
AUDIO AND COMMUNICATION						
Audio controls in steering wheel	•	•		•		•
High Performance Multimedia: AM/FM radio, 1-DVD, MP3, 8 speakers, 7" colour screen	•	•		•		▲
Premium Sound: AM/FM radio, 1-DVD, MP3, 12 speakers, Dolby® Pro Logic® II Surround Sound System, 7" colour screen	\$1,425	\$1,425		\$1,425		•
Auxiliary audio input	•	•		•		•
USB and iPod connectivity	•	•		•		•
Bluetooth including audio streaming	•	•		•		•
Volvo Navigation System (VNS)	\$4,175	\$4,175	•	\$4,175		•
Remote control for audio system	\$125	\$125	\$125	\$125		\$125
SEATING						
Front seat and mirrors electrically adjustable with memory, driver	•	•	•	•		•
Front seat electrically adjustable, passenger	\$2,075	\$2,075	•	\$2,075		•
Front seats, heated	\$325	\$325	\$325	\$325		\$325
Electrically folding rear headrests	\$200	\$200	\$200	\$200		\$200
Two stage dual integrated booster cushions, rear outer seat positions	•	•		•		•
INTERIOR EQUIPMENT						
Rain sensor	•	•		•		•
Park assist, rear	•	•		•		•
Park assist, front	\$325	\$325	\$325	\$325		•
Park assist camera, rear	\$795	\$795	\$795	\$795	\$795	•
Sunroof, glass, electrically operated	\$2,650	\$2,650	\$2,650	\$2,650		\$2,650
Electric park brake with drive-away release	•	•		•		•
Automatically dimmed inner rear view mirror	•	•		•		•
Compass for inner rear view mirror	\$100	\$100	\$100	\$100		\$100
Cruise control and trip computer	•	•		•		•
Windows, electrically operated auto up and down, front and rear	•	•		•		•
Front armrest and cup holders, parking ticket holder	•	•		•		•
Rear armrest with cup holder and storage	•	•		•		•
12V outlet, cargo area	•	•		•		•
Luggage net, backrest	•	•		•		•
Load cover, soft	•	•		•		•
Sunglass holder	\$100	\$100	\$100	\$100		\$100
Grocery bag holder	•	•		•		•

V60	T4	T5	T5 R-Design	D3	T6	T6 R-Design
LIGHTING						
Home Safe, Approach and puddle lighting in door mirrors	•	•		•		•
Illuminated vanity mirror, driver and passenger	•	•		•		•
Foglight, rear	•	•		•		•
Halogen headlights with level adjuster and Volvo DNA lighting	•	•	—	•	•	—
Active Bending Lights (ABL) including headlight wash system	\$2,650	\$2,650	•	\$2,650	\$2,650	•
Headlight wash system	\$275	\$275	•	\$275	\$275	•
INTERIOR TRIM						
Textile floor mats	•	•	•	•	•	•
Leather seat upholstery	•	•	▲	•	•	▲
Inlays (door handles, centre console):						
- Shimmer Graphite	•	•	—	•	•	—
- Charcoal	▲	▲	—	▲	▲	—
- Urbane Wood décor inlays, high gloss	\$700	\$700	—	\$700	\$700	—
Steering wheel, height and telescopically adjustable	•	•	•	•	•	•
Steering wheel, leather, 3 spoke with décor inlays	•	•	—	•	•	—
Steering wheel, leather, 3 spoke with uni décor dual tone	\$900	\$900	—	\$900	\$900	—
Leather gear shift knob	•	•	—	•	•	—
Watch dial instrumentation	\$325	\$325	—	\$325	•	—
R-Design:						
- R-Design sports leather seat upholstery	—	—	•	—	—	•
- R-Design floor mats	—	—	•	—	—	•
- R-Design décor inlays	—	—	•	—	—	•
- Steering wheel, leather, 3 spoke R-Design	—	—	•	—	—	•
- R-Design leather gear shift knob	—	—	•	—	—	•
- R-Design watch dial instrumentation	—	—	•	—	—	•
EXTERIOR						
Rear spoiler with high mount brake light	•	•	•	•	•	•
Silver roof rails	•	•	•	•	•	•
Bright décor around side windows, upper and lower	•	•	•	•	•	•
Electrically retractable door mirrors, with puddle lights, heated	•	•	•	•	•	•
Dual exhaust tailpipes	•	•	•	•	•	•
Bright décor front spoiler foglight area, left and right	\$275	\$275	—	\$275	\$275	—
R-Design grille	—	—	•	—	—	•
R-Design rear view mirrors	—	—	•	—	—	•
Metallic paint	\$1,550	\$1,550	\$1,550	\$1,550	\$1,550	\$1,550
SECURITY						
Central locking with key integrated remote control	•	•		•		•
Global open / close all doors and sunroof	•	•		•		•
Interior door lock buttons and diode indicators, all doors	•	•		•		•
Power child lock, rear doors	•	•		•		•
Electronic immobiliser	•	•		•		•
Laminated front windscreen	•	•		•		•
Tempered side windows	•	•		•		•
Volvo Guard Alarm including Interior Movement Sensor (IMS)	\$850	\$850	\$850	\$850		•
Personal Car Communicator (includes Volvo Guard Alarm)	\$1,575	\$1,575	\$1,575	\$1,575		•
Inclination sensor (includes Volvo Guard Alarm)	\$975	\$975	\$975	\$975	\$125	
Private locking trunk	\$275	\$275	\$275	\$275	\$275	
Water repellent glass, front side windows	\$200	\$200	\$200	\$200	\$200	
Laminated windows including water repellent glass, front side windows	\$525	\$525	\$525	\$525	\$525	

V60	T4	T5	T5 R-Design	D3	T6	T6 R-Design
CLIMATE						
Electronic Climate Control with cabin pollen filter				•		
Electrically heated rear window				•		
IR protected windscreen				\$625		
Tinted windows, rear side doors and cargo area				\$625		
Tinted window, rear cargo area				\$525		
Interior Air Quality System with sensor (IAQS)				\$275		
Clean Zone Interior Package (CZIP) includes IAQS				\$550		
Humidity sensor				\$150		
SAFETY						
Adaptive Cruise Control (ACC) and Collision Warning with Full Auto Brake (CWAB) including Queue Assist and Pedestrian Detection	\$4,175	\$4,175	\$4,175	\$4,175	\$4,175	•
Blind Spot Information System (BLIS)	\$1,275	\$1,275	•	\$1,275	\$1,275	•
Lane Departure Warning (LDW) with Driver Alert Control (DAC)	\$2,075	\$2,075	\$2,075	\$2,075	\$2,075	
City Safety	•	•	•	•	•	•
Anti-lock Brake System (ABS) with Ready Alert Brakes (RAB)	•	•	•	•	•	•
Electronic Brake Distribution (EBD)	•	•	•	•	•	•
Emergency Brake Assist (EBA)	•	•	•	•	•	•
Emergency Brake Light (EBL), flashing	•	•	•	•	•	•
Dynamic Stability and Traction Control (DSTC)	•	•	•	•	•	•
Advanced Stability Control (ASC)	•	•	•	•	•	•
Airbag, driver and passenger, dual stage	•	•	•	•	•	•
Inflatable Curtain (IC)	•	•	•	•	•	•
Pyrotechnical pretensioners, front / rear positions	•	•	•	•	•	•
Seatbelt reminder, all seats	•	•	•	•	•	•
Rear belt detection, left, right and middle belts	•	•	•	•	•	•
Side Impact Protection System (SIPS) with airbags in front seats	•	•	•	•	•	•
Whiplash Protection System (WHIPS)	•	•	•	•	•	•
Intelligent Driver Information System (IDIS)	•	•	•	•	•	•
Warning triangle	•	•	•	•	•	•
First aid kit	\$100	\$100	\$100	\$100	\$100	
ALLOY WHEELS						
8.0 x 17" NJORD	•	•	—	•	▲	—
7.0 x 17" BALDER	▲	▲	—	▲	▲	—
8.0 x 18" SLEIPNER	\$1,600	\$1,600	—	\$1,600	•	—
8.0 x 18" IXION	—	—	•	—	—	•
Tyre repair kit with jack	•	•	•	•	•	•
Lockable wheel bolts	\$150	\$150	\$150	\$150	\$150	\$150
PACKAGES						
Teknik Pack: VNS, ABL with headlight wash system, BLIS, power passenger seat, bright décor front left and right spoiler area, watch dial instrumentation	\$5000	\$5000	•	\$4500*	—	•
Teknik Pack: ACC, CWAB, Queue Assist, Pedestrian Detection, rear park camera, ABL with headlight wash, BLIS, bright décor front left and right spoiler area, watch dial instrumentation	—	—	—	—	\$5000	•

* Vehicles must be purchased from an authorised Volvo dealer. Information is correct at time of printing, however the manufacturer reserves the right to make changes without notice. Please confirm current specification and pricing details with your Volvo dealer. Option pricing displayed is GST inclusive. Accessories and / or options fitted to vehicles may affect vehicle performance, fuel consumption and vehicle emissions.

** D3 Teknik Pack RRP difference due to reduced LCT based on low emissions.

• Standard ▲ No cost option — Not available

Printed October 2011 / MY12 (1)

Welcome to the club. The Volvo V60 Merchandise Collection.

Inspired by the world's sexiest Volvo, this smart collection of lifestyle accessories captures the driving spirit of your new Volvo and reflects the best of modern Scandinavian design. The signature items below are a select few. Find more keepsakes, gifts and apparel at your local Volvo showroom and at www.volvocars.com/collection



Model cars



Key ring



Watch



iPhone case



Driving gloves



Weekend bag



Nailpolish



Pen



Sunglasses



Card holder

MEET THE FAMILY.



Volvo C30 The compact and charismatic SportsCoupe.



Volvo C70 A retractable hardtop convertible that seats four adults with comfort.

Discover Volvo accessories and more detailed information for each car. Visit www.volvocars.com.au



Volvo S40 The compact and energetic saloon.



The all-new Volvo S60 The sleek and sporty saloon, created to thrill.



Volvo S80 The premier saloon, meticulously engineered for superior driving comfort.



Volvo V50 The Sportswagon – flexible, compact and full of zest.



The all-new Volvo V60 The dynamic Sportswagon, created to inspire, designed for an active life.



Volvo V70 The genuine family estate – highly competitive yet comfortably versatile.



Volvo XC60 A sporty coupe and a capable all-roader fused into a Swedish crossover experience.



Volvo XC70 The rugged yet stylish all-roader.



Volvo XC90 The versatile SUV that takes you anywhere with grace.

For further information, please contact your Volvo Dealer or Volvo Car Australia on 1800 7 VOLVO or visit www.volvocars.com.au*
*NZ customers please contact your Volvo Dealer or visit www.volvocars.co.nz



DESIGN THE VOLVO THAT'S REALLY YOU. EXPERIENCE IT INSIDE AND OUT IN 360 DEGREES IN AMAZING 3D. LEARN ABOUT THE DETAILS, TECHNICAL FEATURES AND ACCESSORIES. SEE FILMS ABOUT YOUR FAVOURITE VOLVO AND ITS INNOVATIONS. COMPARE DIFFERENT VOLVO MODELS AND ENGINE ALTERNATIVES. DOWNLOAD IMAGES AND BROCHURES. JOIN THE VOLVO COMMUNITY AND SHARE GREAT CAR STORIES FROM ALL OVER THE WORLD. FIND YOURSELF AT WWW.VOLVOCARS.COM.AU

VOLVO

Volvo Car Australia

August 2011.

Please note: Some of the information in this brochure may be incorrect due to changes in product specifications that may have occurred since printing. Some of the equipment described or shown may now only be available at extra cost. Before ordering, please ask your Volvo dealer for the latest information. The manufacturer reserves the right to make changes at any time and without notice to prices, colours, materials, specifications and models.