



THE ALL-NEW
VOLVO XC90



WE'RE VOLVO CARS.

We put people first.

We're Swedish. Scandinavian designers always start with the person who's going to use an object and ask, "What can we do to make this person's life better, easier or more comfortable?"

We've always used this philosophy when we design our cars. So, while other car manufacturers might start with technology and try to squeeze people in around it, we begin by designing our cars around you. We ask what you need, and then use our technical skills to make your life easier, better, safer and more beautiful. Form follows function, and when you design a car inside and out with people in mind, it looks naturally beautiful. We think that looking at and interacting with our cars should make you feel great, every day.

Designing cars around people has

led to many innovations over our 89-year history. You know the three-point safety belt in your current car? That was our invention from 1959. And now we're working towards our vision to design cars that should not crash. In the shorter perspective, our aim is that by 2020 nobody should be killed or seriously injured in a new Volvo. Of course, you'll already benefit from this research in your current Volvo. We've addressed a few environmental issues, too. In 1976 we developed the Lambda Sond – a sensor that monitors exhaust gas, reducing emissions and boosting performance as well as economy. It's still part of every petrol-engined car in the world. Innovation is at the core of Volvo Cars – it's because of where we come from.

Contents

EXTERIOR DESIGN 04	DRIVE-E 28	BODY COLOURS 40	SPECIFICATIONS 56
INTERIOR DESIGN 08	CHASSIS 34	WHEELS 42	THE VOLVO EXPERIENCE 61
SENSUS 12	ENGINES 36	UPHOLSTERIES 44	
INTELLISAFE 20	TRIM LEVELS 38	ACCESSORIES 50	









We designed the All-New Volvo XC90 for a demanding audience: you. Aficionados of ingenious design and intelligent engineering. Individuals who demand an SUV that expresses who they are; a car that turns every drive into a memorable experience, whether it's in the driver's seat or as a passenger.

This contemporary SUV represents our distinctive take on what it means to drive a luxury car in the 21st century. It's the embodiment of contemporary Swedish design and craftsmanship, both inside and out. Close the doors of your first-class cabin, breathe its refined, clean air, and the stresses of the city fade into the background. Speak commands, touch the screen – you're in complete control. And once you set off, you'll find the All-New Volvo XC90 handles just like a road car. Whether you power down highways or negotiate urban traffic, our clever driver aids take the hassle out of driving, leaving you to enjoy the ride.

This unique and intuitive Volvo driving experience – plus our legendary safety – means you'll always reach your destination calm and unruffled. And because we know you demand power as well as efficiency, our Drive-E powertrains give you both.

“As with any luxury item – a finely crafted watch, a bespoke suit – its beauty might be obvious, but its true value is only revealed when you discover the expertise, the craftsmanship and the passion that went into making it.”

ROAD PRESENCE

Be impressed, quite simply.

You know you're looking at truly great design when what appears simple at first glance turns out to be ingenious and stimulating once you discover the thoughts and details that make up the whole. And as with any luxury item – a finely crafted watch, a bespoke suit – its beauty might be obvious, but its true value is only revealed when you discover the expertise, the craftsmanship and the passion that went into making it.

The All-New Volvo XC90 has this quality. Appropriately for a full-sized SUV, it exudes power, particularly with the upright grille and the strong shoulders, both of which

are classic Volvo style cues. As exterior designer Anders Gunnarsson says, “The car has an attitude that expresses confidence and self-belief. If you're proud and relaxed about your position in the world, you'll stand upright – just like the Volvo XC90.”

But despite this sense of presence, the design is also exquisitely subtle: “It grows on you,” says Thomas Ingenlath, Volvo Cars' Senior Vice President of Design. “It's not all spectacle – it's about leaving the proportions and the technology underneath to create the drama. You suddenly realise how much sheet metal movement there is in the side section – how it grows over the rear wheel.

It's about perfect execution, and that took such a long time to achieve.

The task to design the rear was more difficult, says Ingenlath. “We didn't want to use the elements that everyone else is using to make a car look more powerful. Most other car manufacturers are using horizontal lines. We used vertical lines. That is something that can be difficult. If you are good at it, you give a car an incredible status. We achieved that kind of status by reduction – not going into the horizontal but staying proud and upright. That is a nice aspect.”



V O L V O

XC90



XC90

T6

Light is precious to us in Sweden.

That's why we've designed a large optional panoramic glass roof, which is the perfect complement to the airy, uncluttered cabin.

Don't you love it when a doorman gets the door for you?

With the power-operated tailgate, you can enjoy this courtesy every day – just press a button on your remote, the tailgate or inside the cabin. When you have your hands full, the comfort opening function makes all the difference: wave your foot under a sensor in the rear bumper, and the tailgate opens and closes automatically.

T6 AWD | Momentum | 719 Luminous Sand metallic |
19" 10-Spoke Turbine, Silver, 172





INSIDE YOUR CAR

Your own space, wherever you go.



Travelling in the All-New XC90 always feels special – from the moment you pick up your sculptured remote key. In the lavishly appointed cabin, luxurious materials and superb craftsmanship meet with uncluttered elegance. The airy interior gives you the luxury of space and calm – no matter which of the three seat rows you sit in. The mood of tranquil seclusion is accentuated by

eye-catching details like the ‘flying wings’ controls, inspired by high-end amplifiers. Other touches include the diamond-knurled control surfaces and the beautifully framed tablet-sized centre display with touchscreen, which takes pride of place in the centre stack. Our CleanZone technologies filter out harmful gases and particles, ensuring that you and your passengers breathe easy – even in

polluted cities. And you’ll love our 19-speaker Premium Sound by Bowers & Wilkins™, which offers sublime concert-quality sound for the most exacting audiophiles.

Fine Nappa Leather Blond in Blond/Charcoal interior UC00 | Linear Walnut



The interior of the Volvo XC90 is truly special. It embodies our designers' vision to create a space that combines a contemporary take on luxury with timeless seclusion.

FIND OUT MORE AT VOLVOCARS.COM.AU

Fine Nappa Leather Blond in Blond/Charcoal interior UC00 | Linear Walnut



“The sculptured seats offer 21st-century luxury in look, feel and style while allowing more rear legroom. And you can rest assured that they’ve been designed in line with the latest ergonomic research.”

Everyone travels first class in the Volvo XC90.

When we designed the All-New Volvo XC90, we made sure you travel in first class, no matter where you sit. The sculptured seats offer 21st-century luxury in look, feel and style while allowing more rear legroom.

And you can sit easy in the knowledge that they’ve been designed in line with the latest ergonomic research. If you’d like to enhance their lavish comfort even further, you can order heating, massage and ventilation, power-operated lumbar support,

extendable seat cushions and side bolsters. You’ll never want to get out of your car. In the second row, the three individual seats are designed for maximum comfort – each of the three seats slide and recline individually. Thanks to the four-zone climate system, passengers in the outer two rear seats can set temperature and fan speed to their individual taste – and the same goes for the driver and the front passenger. And to make sure your phone or tablet never runs

out of charge, there’s access to a power outlet and a USB port. For better visibility, there’s ‘theatre seating’ – the rear rows are positioned higher up than the seats in front.

In true Volvo style, we’ve also remembered younger passengers – children who’ve outgrown their child seats can use the integrated booster cushion in the second row. And the third-row seats can be popped up or lowered flat.



This is the first of a completely new generation of nimble Volvo steering wheels, combining a graceful rounded square in the centre with a contemporary interpretation of our classic three-spoke design.



Jewel-like touches such as controls with diamond-knurled finishes and translucent edges underline our designers’ meticulous attention to detail.



The four-zone climate system can be controlled from the centre display touchscreen, or a graceful touch control panel at the end of the tunnel console.



“When we designed this stunning interface, it was our overriding ambition to eliminate as many physical switches and buttons as humanly possible.”

SENSUS

The intuitive way to interact with your car.

We aimed for the All-New Volvo XC90 to be as natural, intuitive and human to interact with as possible. Volvo Sensus is our unique way of enabling you to communicate instinctively with your car and to connect to the digital world.

As an impressively advanced car, the All-New XC90 has a wealth of features and functions that would have been unthinkable just a short time ago. That's why it's all the more important that you should be able to access whichever support, information or entertainment function you need almost instinctively. We think you'll find that Sensus lives up to this task. And because we love good design, it's also beautiful to look at and enjoyable to use.

When we thought about how drivers would interact with the All-New XC90, we aimed to eliminate as many physical switches and buttons as humanly possible. We achieved this by moving these controls – for climate, entertainment and anything else that makes life easy – into our 9-inch centre display with touchscreen: a Volvo first. Not only that, we've also given the All-New Volvo XC90 voice control for the functions you'll use most frequently: simply select the menu you want and talk to your XC90 in a natural, human way. Thanks to all this, our designers were able to create a clean, uncluttered Swedish interior with just a few jewel-like physical controls – which made them very happy indeed.

Communication is a two-way street. So we didn't just simplify the way you can interact with your All-New XC90. We've also streamlined the way the XC90 communicates with you. Any information you need to see straight away – for example, speed limits or navigation arrows – flashes up on the windscreen, in the optional head-up display. (If you don't have that option, this information stays in the driver display in the dashboard.) Less urgent information – for example, current speed or fuel level – appears in the driver display, while anything you need to know or do whenever you have time (such as climate and entertainment) has its place on the centre display with touchscreen.

“Our sound systems turn any drive into a truly momentous experience.”

Connect with all your senses.

Nothing rounds off a drive in your car better than luxuriating in the rich sound of your favourite piece of music. And our two sound systems – Premium Sound by Bowers & Wilkins™ and High Performance Sound – turn any drive into a momentous experience.

Thanks to Sensus Connect, which is standard, you can stream your favourite tunes from your device to your car via Bluetooth®. You can also use Bluetooth® or

WiFi tethering to connect your XC90 to the internet via your device. You can then browse the web and access a variety of internet radio and media apps.

With Sensus Navigation as standard, you can view your route on the centre display via with touchscreen. And with the forthcoming Apple CarPlay, you can use the centre display to access your iPhone® as well (version 5 or later).

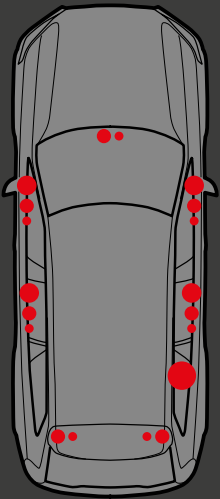

Premium Sound by Bowers & Wilkins™ embodies our quest for perfection. The numbers are impressive: one 12-channel amplifier, 1400W output, 19 speakers including two automotive innovations: a new type of sub-woofer, which is both very powerful and space-saving, and a tweeter facing the cabin for outstanding sound quality. But our pursuit of the definitive sound system went beyond mere technical facts. Our sound systems engineers searched obsessively for audiophile perfection. When they listened to a concert in Gothenburg's Konserthuset, they knew they'd found it.

Using a radically new approach called acoustic holography, the team took the Konserthuset's unique fingerprint – its very own sound profile – and reproduced it in the car. The result, our Concert mode, speaks directly to any music lover's soul – regardless of which of the seats you travel in. Our two other audio modes, Studio and Stage, allow you to create exactly the sound you want. Apart from this very high-end package, there's also our High Performance sound system, which delivers a crisp, natural sound at a quality that's very rare in this class.

SENSUS

The central touchscreen display is framed in a dark, metallic-looking bezel. At the top, it shows signal strength, Bluetooth, Wi-Fi, and USB icons, along with the time 15:49. The main interface is divided into several sections: 'Navigation' showing 'Bråland 522' and 'Next exit: 90-Stora Högamotet'; 'Media - Bluetooth' displaying 'Arizona Rain/ Color Me' and 'The Skies Belong To Us' with a track duration of 1:02 and a total duration of 3:55; a music library with 'Shuffle' selected, listing 'Wave Goodbye', 'Arizona Rain', 'Color Me', 'The Skies Belong to Us', and 'Nights'; 'Phone' information for 'Telenor Daniel's Phone' with a battery icon; and a climate control section at the bottom showing '22°C' on both sides and 'AUTO' in the center.

A beautifully designed display. Our gorgeous centre display with touchscreen is an eye-catching feature in the interior, epitomising our Swedish design philosophy of marrying form with function. You'll notice that it's very glossy and black, and yet we've kept glare to an absolute minimum. The display is beautifully complemented by our 'flying wings' controls, which evoke the purposeful reduction and simplicity of high-end amplifiers. Press 'play' and you'll find that our two sound systems live up to the association every time.

FIND OUT MORE AT VOLVOCARS.COM.AU



SENSUS



The beauty of information.

True to our Swedish design heritage, we've created an interface that's as functional as it is beautiful. The head-up display presents information as if it's hovering two metres in front of the car, so you never need to look away from the road. And because the projections are semi-transparent, they don't obscure your vision: you'll find this particularly useful with Sensus Navigation, which uses the head-up display for its navigation arrows.

The colour scheme of the full graphical 12-inch driver display in the dashboard corresponds to the drive mode you've chosen, such as Comfort, Sport and Classic. When the ignition is turned off, the display has a glossy black, hi-tech look.

Our tablet-sized centre display with touchscreen is vertical, which is innovative and practical. We've placed large touch buttons at the bottom of the screen, where they're easy to reach, and information for viewing at the top. You'll also find that this format makes following routes on maps easier, as more of them can be displayed – and you don't need to scroll up and down all the time.

Being Swedish, we've also made sure that this glossy, anti-glare screen responds to the lightest touch, even when you're wearing gloves.

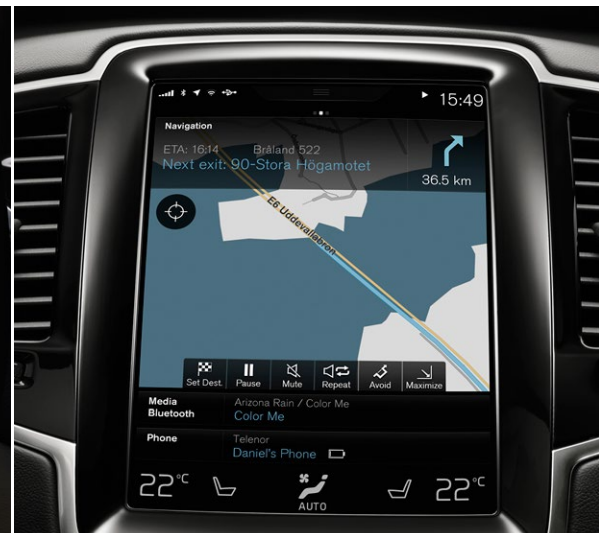

Talk to me. The easiest way to interact with your car is by talking to it. That's why we've linked the most commonly used functions to voice control. But don't worry – you don't have to learn a list of robotic commands. We've collected a vast bank of phrases people use in real-life situations and trained voice control to understand them – in more languages than ever, which means you can now speak to your car in a way that comes naturally to you.

The short way home. Sensus Navigation makes use of the centre display with touchscreen by showing your route in the largest possible format. And with the optional head-up display, you'll be guided by navigation arrows hovering in front of you. As the system is connected, you have access to apps like Local Search, Weather and Send to Car. Best of all, Sensus Navigation has voice control, so all you have to do is say where you want to go.







Light up the dark. Our 'Hammer of Thor' LED lights combine an impactful look with safety and convenience. They have an especially wide and long light pattern and are among the brightest on the market. The LEDs last the lifetime of the car without losing any of their brightness. The distinctive, hammer-shaped light-guides not only act as daytime running lights – they also flash in a warm tangerine colour when indicating.

FIND OUT MORE AT [VOLVOCARS.COM.AU](https://www.volvocars.com.au)

T6 AWD | R-Design | 720 Bursting Blue metallic | 22" 5-Double spoke, Matt Black/Diamond Cut, 175

“Our vision is to design cars that should not crash.”

INTELLISAFE

We protect what's most important: You and your family.

The XC90 is packed with intuitive safety technologies as standard. They support you in your daily driving, help you avoid or mitigate collisions and protect you in the event of an accident. Most of the time, you won't be aware of these helpers, but they're watching out for you, day or night. We call this comprehensive, innovative approach to your safety IntelliSafe.

This commitment goes back to 1927. Our founders, Assar Gabrielsson and Gustaf Larson, stated that “cars are driven by people, so the guiding principle behind everything we make at Volvo is, and must remain, safety”. Nearly 90 years on, our vision is to design cars that should not crash. In the shorter perspective, the aim is that by

2020 no-one should be killed or seriously injured in a new Volvo. We think our founders would have approved.

The All-New Volvo XC90 is yet another step towards this ambition. In 2008, we launched City Safety – the world's first collision avoidance technology. In the All-New Volvo XC90, City Safety has become more capable and versatile than ever. Day and night, it can help avoid or mitigate collisions with other cars, pedestrians and cyclists in your path. And now, City Safety also includes Braking in Intersection – another world-first from Volvo Cars. If you should turn into the path of an oncoming car at a junction, your XC90 will brake automatically to mitigate a collision

or prevent it altogether. The standard IntelliSafe technologies also include preventive safety features such as Road Sign Information, Lane Departure Warning and Electronic Stability Control. And it goes without saying that you also get Volvo's legendary strength.

If you'd like to build on this, the IntelliSafe Surround option is designed to alert you to hazards all around your car, while the IntelliSafe Assist option assists you for a relaxed drive in the city or on the highway. For example, it can help you to keep a safe distance to the car ahead and avoid lane drifting by gently steering you back to your lane if it's needed.



City Safety senses if you're about to collide with the car in front and applies the brakes. The system is active at all speeds and can reduce your speed by up to 50km/h. In many situations, this can help you avoid collisions altogether or help to reduce the severity of a crash. As a world-first, City Safety also brakes if you're about to turn into the path of an oncoming car, again helping you to avoid or mitigate a collision.

City Safety also watches out for pedestrians and cyclists, even at night. This is particularly important as pedestrians and cyclists are much harder to see than cars in low light. Should a pedestrian or bike veer into or across your path, City Safety brakes to avoid or mitigate a collision.

The BLIS system uses radar sensor technology to alert you to vehicles in your blind spot and to vehicles approaching fast from behind in the adjacent lane. There's also Cross Traffic Alert, which watches out for vehicles you can't see – up to 30 metres away – when you're reversing out of tight parking spaces.

READ MORE AT VOLVOCARS.COM.AU

T6 AWD | Inscription | 707 Crystal White pearl | Exterior Styling Accessories Urban | 21" 10-Spoke Turbine, Polished



INTELLISAFE





Tight car parks and narrow city streets need never again be stressful to manoeuvre - with the optional 360° camera, you get a bird's-eye, uninterrupted view of the car's surroundings on the centre display.

Would you like your car to park for you? Then let Park Assist Pilot do the work, and manoeuvre you into a vacant space. Not only can this technology parallel park, it can also handle perpendicular parking. Once it detects a suitable gap, it takes over the steering and guides your XC90 into place - all you need to control is the brake and the accelerator. The technology is so precise it can park in spaces you wouldn't even normally consider: when parallel parking, for example, a space just 1.2 times the length of the car is enough.

READ MORE AT VOLVOCARS.COM.AU

T6 AWD | R-Design | Panoramic Roof | 720 Bursting Blue metallic | 22" 5-Double Spoke, Matt Black / Diamond Cut, 175



INTELLISAFE



Your safety is our mission.

As proactive as the safety technology is, a vital step when creating an extremely safe car is designing protective strength around the passenger compartment. At Volvo Cars, we pioneered the use of ultra-high-strength steel in our safety cages. In the All-New XC90, we have made extensive use of this extremely tough material. But an intelligent structure needs to dissipate energy as well as resist it. That's why we've engineered the

XC90 to include strategically placed softer segments in different steel qualities, which act as front and rear crumple zones.

One of the pioneering innovations in the first-generation XC90 was our roll-over protection system. For the All-New XC90, we applied the same philosophy in a brand-new design.

In typical Volvo style, we also want to protect other motorists. That's why we've

developed our lower crash structure – it means the XC90 is compatible with smaller cars' crumple zones. And it means you can drive your XC90 with a clear conscience.

We designed the safety technologies of your XC90 to help protect people of different size and age. For example, a child over four years of age will ride in comfort and be safely positioned in our integrated booster cushion on the second row's centre position.



Rear Collision Warning with braking at standstill, which is part of IntelliSafe Surround, detects if you're about to be hit from behind and warns the driver behind by flashing your hazard lights at a high rate. If a collision can't be avoided, the front safety belts are tightened to keep you in position. And just before impact, the brakes are applied to help protect you and your passengers from whiplash injuries.

Our Run Off Road Protection technology is a safety world-first. When the system senses an imminent running-off-road scenario or a collision, it automatically tightens the front safety belts with two levels of force to keep you at a safe position. And to help protect your spine if the car lands hard during an accident, we designed the front seat frames and seat cushions to help absorb severe vertical forces. If a collision is avoided, the front safety belts unroll again without needing to be serviced.

INTELLISAFE





MARIA HISSEN

6,8

Bastugatan
14a-17a

“The key to this is our all-new, lightweight, low-friction, turbocharged 2.0-litre four-cylinder engine, which is coupled with our newly designed automatic eight-speed Geartronic® transmission.”

DRIVE-E

Enjoying more. Using less.

Drive-E is our all-embracing approach to efficient power and an uncompromising driving experience. Our new-generation Drive-E powertrains play a central role in this. In fact, they redefine how luxury cars will be powered in the 21st century. Yes, they deliver the performance and driving enjoyment you'd expect from a luxury SUV. But thanks to our unrelenting commitment to efficiency, they reduce the impact on the environment as well. All this means you get power and superb driveability together with low fuel consumption and CO₂ emissions.

The key to this is our all-new, lightweight, low-friction, turbocharged 2.0-litre four-

cylinder engine, which is coupled with our newly designed automatic eight-speed Geartronic® transmission. And to maximise the efficiency of our Drive-E powertrains, there's an ECO mode, which calibrates the gearbox and engine control systems for the lowest possible fuel consumption. ECO mode also softens the throttle response to further boost efficiency. And because the air-conditioning affects fuel use, it is disengaged in ECO mode (although it can be switched on manually).

Then there's the Eco-Coast function, which uses the car's kinetic energy to save fuel. When the driver stops pressing the

accelerator at speeds above 65km/h, there is no engine braking; the car just coasts along with the engine at idle. And, finally, the Stop/Start engine technology also plays its part in lowering fuel consumption.

Our Drive-E diesel powertrain benefits from additional, diesel-specific technology. With twin turbos and the revolutionary i-ART direct fuel injection, this intelligent engine provides responsive, clean and efficient performance – each cylinder has its own microchip and pressure sensor for the perfect metering of fuel. Better still, this advanced engine remains in precise tune even after years of use.

DRIVE-E



No matter where you are in Sweden, forests and fresh air are never far away. For us at Volvo Cars, this is an inspiration and an obligation. We think that everyone should be able to enjoy the cleanest possible environment – even in surroundings with high levels of pollution. That’s why we’ve created CleanZone: it’s our comprehensive approach to a clean interior in your car.

As part of CleanZone, we test all our interiors to ensure none of them emits any odours or harmful gases. We also take care that all materials are hypo-allergenic. Then there’s

our newly developed cabin filter, which comes as standard. It greatly reduces the levels of dust, pollen and particles entering the cabin, even if they’re of a very fine size.

On top of this, our CleanZone interior air quality system has an active charcoal multi-filter that protects you and your passengers from harmful vehicle emissions, such as carbon monoxide and nitrous oxides, and diesel particles. The system also opens and closes the air vents automatically. It constantly measures the quality of the air entering the cabin and switches to recirculation mode if it detects harmful gases, opening the vents again when conditions are appropriate.

T6 AWD | Inscription | 717 Onyx Black metallic |
21" 8-Spoke, Silver/Diamond Cut, 174

“Our very powerful T8 Twin Engine delivers astonishing performance without compromising on fuel efficiency and low emissions.”



Double power.

Nothing encapsulates our fresh thinking on 21st-century luxury and performance better than our top-of-the-range T8 Twin Engine plug-in hybrid. Combining a supercharged and turbocharged 2.0-litre Drive-E petrol powertrain with an electric motor, the T8 Twin Engine puts out an astonishing amount of kilowatts, which is accompanied by a jaw-dropping amount of torque. But it can also deliver fuel consumption that would put a compact car to shame. Not only does this plug-in hybrid offer scintillating performance and amazing fuel efficiency, but the XC90 T8 Twin Engine AWD also handles supremely well thanks to the compact, high-capacity battery being mounted centrally along the transmission tunnel.

It's versatile, too – the T8 Twin Engine features different driving modes to suit virtually any driving environment. Pure mode is all about reducing fuel consumption and emissions. Working at speeds of up to 125km/h, it uses electric power as much as possible, sending it to the rear wheels. This mode packs ample reserves: a full battery suffices for most people's daily commute. But because the high-performance petrol engine can be called upon at any time, there's never any worry about battery range.

Hybrid is the default mode. Geared to maximum comfort, this uses the electric motor at the rear wheels as well as the petrol engine, which drives the front wheels. It does this either individually or in parallel to achieve

an optimum balance between performance and efficiency.

The Power mode, on the other hand, unleashes the combined forces of petrol and electric at the same time to all four wheels, while steering, transmission and brakes are tuned for sportiness. The AWD (all-wheel drive) mode improves traction and, in addition, the Off Road mode engages an electronically controlled limited-slip differential function and can help you negotiate poor roads at speeds below 40km/h. So your XC90 can be a silent-running zero-emission city car, a blistering performance SUV, or a reassuring companion in challenging conditions.



Our plug-in hybrid technology means you get an uncompromising driving experience with excellent fuel economy and low CO₂ emissions all at the same time. That's why this solution is as important today as it is in our future.

Our XC90 T8 Twin Engine plug-in hybrid is the latest milestone on this journey. In addition to a supercharged and turbocharged high-performance petrol engine, it has a potent electric motor which delivers instant and impressive torque to the rear wheels. This motor is powered by high-capacity batteries mounted centrally along the transmission tunnel. It's an intelligent positioning which gives you excellent weight distribution and, as a consequence, outstanding handling.

The T8 Twin Engine can handle most people's daily commutes in pure electric mode – but because the high-performance petrol engine can be called upon at any time, there's never any worry about battery range.

READ MORE AT VOLVOCARS.COM.AU

T8 Twin Engine | R-Design | 720 Bursting Blue metallic | 22" 5-Double Spoke Diamond Cut/Matte Black, 175



DRIVE-E



Firm control with a velvet touch.

The All-New XC90 also incorporates our very latest electronic support systems that constantly adjust to changing road conditions and driving styles. For example, our hill start assist function makes it easier to start off on a steep hill. And for difficult roads and poor weather conditions, all-wheel drive and hill descent control ensure you embark on your journey with confidence.

The XC90 is available with air suspension on all four wheels, which includes an advanced, electronically controlled damper system. Not only does this give you outstanding ride comfort, you also have the option to choose between different drive modes that cater to individual driving styles and increase the car's versatility in all road and weather conditions.

In Comfort mode, the air suspension is tuned for maximum comfort while Eco mode optimises settings for low fuel consumption and CO₂ emissions. Dynamic or Power mode lowers the car by 20 millimetres at higher speeds to optimise aerodynamics and handling, while the Off Road mode increases ground clearance by 40 millimetres at low speeds. The modes are simple to change using an elegant and ergonomic roller control between the front seats.

With the air suspension system, you can also lower the rear of the car by 50 millimetres by pushing a button inside the load area. This makes it easier to lift heavy items into (or out of) your car, or to attach a trailer to its tow hook.



Choose the Off Road mode and the air suspension will raise the car by 40 millimetres. Hill Descent Control is activated at the same time – the car brakes for you on steep gradients; all you need to do is steer. The Off Road mode gets your XC90 to navigate challenging terrains – all you need to do is turn the elegant drive mode selector to the desired position.

READ MORE AT VOLVOCARS.COM.AU

T6 AWD | Inscription | 707 Crystal White pearl | Exterior Styling Accessories Rugged | 22" 6-Double Spoke Matt Tech Black/Diamond Cut

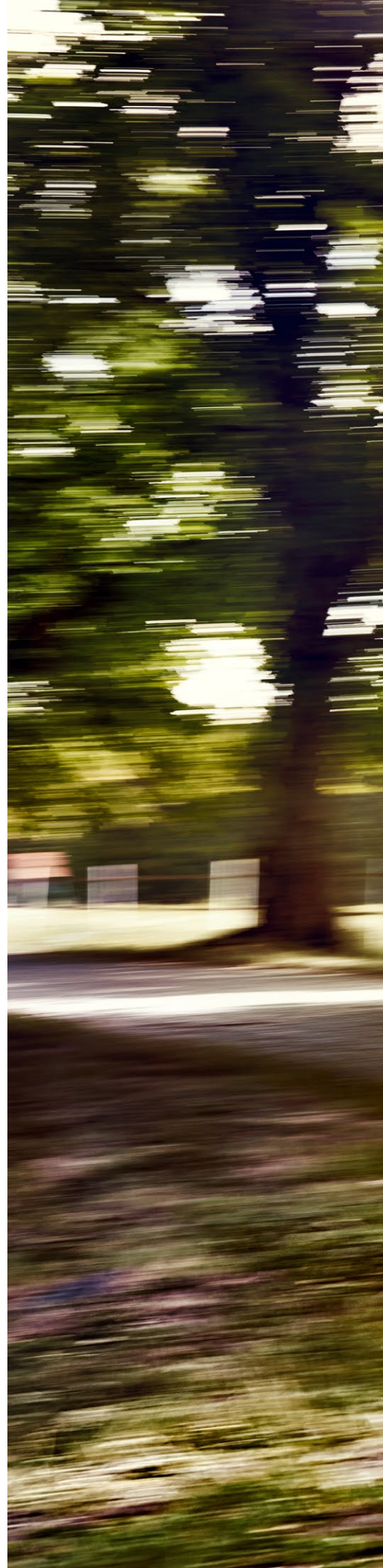



Big heart in a small package.



T8 Twin Engine | 235kW + 65kW | 400Nm + 240Nm | 2.1 l/100km

T6 AWD | 235kW | 400Nm | 8.5 l/100km

D5 AWD | 165kW | 470Nm | 6.2 l/100km

READ MORE AT VOLVOCARS.COM.AU

T6 AWD | R-Design | 720 Bursting Blue metallic | 22" 5-Double Spoke, Matt Black/Diamond Cut, 175

Please note T8 Twin Engine figures shown are based on European testing. Please check with your Volvo dealer for the latest local information.

Our efficient, smooth and responsive Drive-E powertrains prove that you don't need a big engine to get big performance – our new 2.0-litre four-cylinder design is capable of generating high power outputs. And all have been engineered with low fuel consumption and emissions in mind. Our 235kW high-performance petrol engine

uses both supercharging and turbocharging to deliver great performance. And our top-of-the-range Twin Engine plug-in hybrid develops an exhilarating 295kW. Or choose our high-performance 165kW twin-turbocharged diesel engine. It uses the advanced i-ART technology for responsive, fuel-efficient performance.



The choice is yours.

Choosing your All-New Volvo XC90 was the easy part. Now all you have to do is give it the twist that best matches your personality. Momentum is our most accessible package,

whereas if you're aiming for top-of-the-range luxury, you'll love Inscription with its distinctive grille. Finally, the R-Design is all about a sporty look, both inside and out.

XC90 MOMENTUM

Includes:

Exterior:

19" Aluminium wheels | Active High Beam (AHB) | Automatically dimmed exterior rear view mirrors | Bright decor exterior, front | Bright decor strip, outer door handles | Daytime Running Lights (DRL) | Dual visible tailpipes with chrome sleeves | Front grille in high gloss black with chrome frame | Fully colour adapted sills and bumpers | Headlight high-pressure cleaning | LED headlights with Active Bending Lights (ABL) | Park assist pilot with front and rear park sensors | Power-operated tailgate | Rain sensor | Retractable side view mirrors | Silver roof rails | Touring chassis | Wet arm wipers

Interior:

12.3" graphical instrument cluster | 9" centre display | Automatically dimmed inner rear view mirror | AUX and USB connections | Cargo divider under load floor | Cargo opening scuff plate in stainless steel | Child seat booster cushion | CleanZone | Collision mitigation support, front | Comfort seats, in leather | Crossed Brushed Aluminium decor inlays | Cruise control | Electronic Climate Control Four Zone | Four-way power adjustable front seat lumbar support | Hill Descent Control | Hill start assist | Humidity sensor | Interior mid-level illumination | Keyless start | Lane departure warning | Leather steering wheel with décor inlay and leather gearshifter | Luggage area 12V power outlet | Metal tread plates, front and rear | Park assist camera | Power cushion extension, driver and passenger seat | Power driver seat with memory function for seat and side mirrors | Power passenger seat, with memory function | Rear door power child locks | Road Sign Information (RSI) | Semi-automatic load cover | Sensus Connect High Performance audio | Sensus Navigation | Temporary spare wheel | Textile floor mats | Third Row Climate Control



XC90 INSCRIPTION

Includes Momentum equipment level plus the following:

Exterior:

20" Inscription aluminium wheels | Bright decor exterior | Bright decor side moulding with embossed Inscription logo | Bright integrated roof rails | Dual integrated tailpipes | Hands-free tailgate opening | Illuminated door handles and puddle lights | Inscription front grille | Keyless entry

Interior:

12.3" Full graphical instrument cluster | Collision warning mitigation support, front and rear | Comfort seats, in Nappa leather | Illuminated metal tread plates | Inscription carpet set | IntelliSafe Surround including Blind Spot Information System (BLIS) with Cross Traffic Alert (CTA) | Interior high level illumination | Leather key remote | Metal Mesh decor inlays



XC90 R-DESIGN

Includes Momentum equipment level plus the following:

Exterior:

20" R-Design aluminium wheels | Bright integrated roof rails | Mirror caps in matte silver | R-Design dual integrated tail pipes | R-Design front grille | R-Design front spoiler | R-Design silk metal window trim

Interior:

12.3" Full graphical instrument cluster | Charcoal headlining | Collision warning mitigation support, front and rear | Drive mode settings | Gearshift paddles | IntelliSafe Surround including Blind Spot Information System (BLIS) with Cross Traffic Alert (CTA) | Interior high level illumination | R-Design carbon fibre décor inlays | R-Design carpet set | R-Design Contour seats in perforated Nappa leather | R-Design illuminated tread plates | R-Design leather key remote | R-Design pedals | R-Design perforated leather steering wheel and gearshifter

T8 R-Design only additional or alternative equipment level to standard R-Design:

19" front and 18" rear brake discs | Charge connector with charge plug and cord | Crystal Gearshifter | Front wheel drive with Electric Rear Axle Drive | Panoramic sunroof | Preventilation and prolonged heating after engine shut-off | Tyre Repair Kit (Temporary spare wheel not available)



The exterior colour you choose has a dramatic impact on the personality of your XC90. But no matter which you choose, each one imbues the car with a sense of luxury and presence.

"Our colour palette is very Scandinavian," says Ebba Maria Thunberg, who is responsible for

colours and materials. "When you look at our palette, you'll find that it contains softer tones that are more connected with nature." Being Swedish, our designers are inspired by the ocean and the sky, but also by the shore and the way the light changes throughout the seasons. Every tone speaks of uniqueness, quality and charisma.



614
Ice White
(Also available for R-Design)



707
Crystal White pearl metallic
(Also available for R-Design)



477
Electric Silver pearl metallic
(Also available for R-Design)



467
Magic Blue metallic



717
Onyx Black metallic
(Also available for R-Design)



487
Ember Black pearl metallic



612
Passion Red
(Exclusive to R-Design)



711
Bright Silver metallic
(Also available for R-Design)



720
Bursting Blue metallic
(Exclusive to R-Design)



714
Osmium Grey metallic
(Also available for R-Design)



492
Savile Grey metallic
(Also available for R-Design)



700
Twilight Bronze metallic



719
Luminous Sand metallic



From expressive to discreet, elegant to sporty, you can give your XC90 a unique twist by the wheels you choose.

Would you like to make an entrance or do you prefer the charm of the understated? Are you going for a sporty persona or an intricate, refined look? Try different wheels on our online configurator and find the one that's right for you.

22", 5-Double Spoke, Matt Black/Diamond Cut, 175 (R-Design)



19", 10-Spoke Turbine,
Silver, 172



20", 10-Spoke,
Silver/Diamond Cut, 173



18", 5-Spoke,
Sparkling Silver, 233



20", 5-Spoke,
Matt Black/Diamond Cut
(R-Design)



20", 5-Double Spoke,
Matt Tech Black/Diamond Cut, 234



19", 6-Spoke Turbine,
Silver, 177



21", 8-Spoke,
Silver/Diamond Cut, 174



18", 6-Double Spoke,
Sparkling Silver, 228



21", 10-Spoke Turbine,
Polished
(Accessories)

SWEDISH INTERIOR DESIGN

Personalise your living space.



We're very proud of the interior in the All-New XC90. Every detail, every line, every shape is testimony to our designers' untiring pursuit of their vision: to create a space in which you feel relaxed, at peace and in complete control. It's an airy, uncluttered cabin, which gives you astonishing scope to choose the upholstery and interior trim that suits your personality.

Choose the interior and seats in charcoal to create a dynamic, cockpit-like feel, the warm amber option to convey the mood of a luxurious lounge, or our futuristic blond theme. Then, you can complement the look by accenting the cabin with aluminium, wood, carbon fibre or charcoal décor panels. There are two seat types: the standard comfort seats are designed to ensure a pleasant and luxurious drive even on the longest journey.

They're available in leather and fine nappa leather. Then there are the power-operated, sculptured contour seats, which are available in a combination of fine nappa leather and nubuck textile, particularly suited to dynamic driving. In the R-Design version, the contour seats are standard and upholstered in perforated fine nappa leather. You also have a choice between steering wheels – one dark, and one in a two-tone design.



The remote key fob is an excellent example of the craftsmanship and clean design inside your XC90. For the Inscription and R-Design variants, it's clad in the same leather as your seats.



Contour seat



Comfort seat

INLAYS



Dark Flame Birch



Cross Brushed Aluminium



Metal Mesh

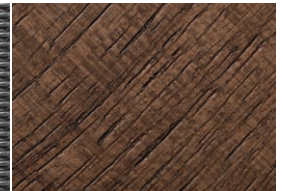

Linear Walnut

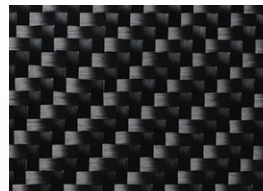

Carbon Fibre
(Exclusive to R-Design)



Leather

Fine Nappa Leather

**Fine Nappa Leather,
Perforated**

**R-Design Nubuck textile /
Fine Nappa Leather, Perforated /
Fine Nappa Leather**



**Blond Leather
(Comfort seat), UA00**

in Blond/Charcoal interior with Blond headlining and Dark Flame Birch inlay

**Also available in the
Blond/Charcoal interior:**

- Blond Fine Nappa Leather (Comfort seat), UB00
- Blond Fine Nappa Leather, Perforated (Comfort seat), UC00
- Blond Fine Nappa Leather (Contour seat), UB01



**Charcoal R-Design
(Nubuck textile / Fine Nappa Leather) (Contour seat), RB0R**

in Charcoal interior and Carbon Fibre inlay

**Also available in the
Charcoal interior:**

- Charcoal R-Design (Fine Nappa Leather, perforated) (Contour seat), RC0R
- Charcoal Leather (Comfort seat), RA00
- Amber Leather (Comfort seat), RA20
- Charcoal Fine Nappa Leather (Comfort seat), RB00
- Amber Fine Nappa Leather (Comfort seat), RB20
- Charcoal Fine Nappa Leather, Perforated (Comfort seat), RC00
- Amber Fine Nappa Leather, Perforated (Comfort seat), RC20
- Charcoal Fine Nappa Leather (Contour seat), RB01
- Amber Fine Nappa Leather (Contour seat), RB21

**Blond Fine Nappa Leather
(Contour seat), WB01**

in Blond interior with Blond headlining
and Metal Mesh inlay

Also available in the Blond interior:

Blond Leather (Comfort seat), WA00

Blond Fine Nappa Leather
(Comfort seat), WB00

Blond Fine Nappa Leather,
Perforated (Comfort seat), WC00



**Blond Fine Nappa Leather,
Perforated (Comfort seat), QC00**

in Blond/Espresso interior with Blond
headlining and Linear Walnut inlay

**Also available in the
Blond/Espresso interior:**

Blond Leather (Comfort seat), QA00

Blond Fine Nappa Leather
(Comfort seat), QB00

Blond Fine Nappa Leather
(Contour seat), QB01



Urban luxury.



Fashion designers know that an elegant shape can be enhanced by the correct accessories. It's the same with cars. Do you seek a sophisticated, refined persona? Or do you wish to show the world a tougher, more rugged edge? Our two styling kits transform the appearance of your XC90 to match your personality.

With well-judged touches of stainless steel, the Urban Luxury Styling Kit adds a luxurious sparkle to your XC90. The front décor frames feature abundant chrome and mesh. Together with the skid plate in stainless steel and the lower spoiler with mesh detailing, they give your XC90 a luxurious and dynamic impression. For the sides, the body kit with its wheel arch extensions and door trims give your XC90 a more muscular appearance.

And by accentuating the horizontal, the side scuff plates emphasise the sleekness of the XC90's shape. The rear bumper gets an exclusive skid plate in stainless steel and a lower spoiler whose styling and mesh accents give the tail-end of your XC90 a dynamic attitude. The integrated double tailpipes are included and complete the look of elegant power.



Rugged luxury.



With its tech matt black accents, the Rugged Luxury Styling Kit gives a no-nonsense, go-anywhere feel to your XC90, showing the world that you're ready to take on any challenge.

Give your XC90 an assertive, rugged expression all round. The front décor frames add a real sense of purpose, combining

chrome surfaces with mesh detailing. Then there's the eye-catching skid plate in stainless steel for the front bumper, which also includes a lower spoiler. Again, sporty mesh detailing adds to the confident appearance. On the sides, our body kit has wheel arch extensions and door trims in tech matt black for that rugged feel. You can enhance this further with our eye-

catching running boards. They have subtle light strips that guide you as you enter and exit after dark. A stainless-steel skid plate adds another touch of luxury to the rear bumper. It harmonises beautifully with the lower spoiler in tech matt black and mesh accents, further enhancing the tough stance. Double integrated tailpipes provide a powerful finishing touch.

Create an XC90 that's perfect for your life.

With our range of accessories, you can create your own unique XC90 that fits in perfectly with your life. Take the Illuminated Tailgate Scuff Plate. With its illumination around the edges, it immediately elevates your load compartment from a practical storage space to a luxurious extension of the interior. The Red Key is ideal if your older children have just learned to drive. It's natural that they should want to try your

XC90, too. The Red Key limits the car's top speed to 120km/h by default. It also limits the audio volume and sets the Adaptive Cruise Control to the longest possible distance. All this goes a long way to make you feel at peace as a parent. And even if you don't have children, the Red Key comes in handy if you give your car to a valet, or leave it with a garage. Of course, you can adjust the Red Key's settings as you see fit.

If you've fallen in love with the interior wood trim in your car, our key fobs made from Linear Walnut or Flame Birch allow you to carry a little piece of Scandinavia in your pocket.



The Red Key remote limits the car's top speed and audio volume - all to make you feel at peace when leaving your XC90 to someone else, for example a young adult.



The steel grille prevents loads from being thrown forward in a collision. The longitudinal load compartment divider separates the compartment, and the dog gate keeps your dog safely where it belongs.



You can enhance the rugged feel with our eye-catching integrated running boards. They have subtle light strips that guide you as you enter and exit after dark.



If you have an active lifestyle, our roof load carriers are a must. They're specially designed to fit neatly and securely into the mounts and combine with any other holders you might need. No matter which sport you like, our specially designed holders – such as the kayak holder shown here – combine safety with ease of use.

T6 AWD | Inscription | 707 Crystal White pearl | Exterior Styling Accessories Rugged | 22" 6-Double Spoke Matt Tech Black/Diamond Cut



SEE MORE LIFESTYLE ACCESSORIES AT
[COLLECTION.VOLVOCARS.COM](https://collection.volvocars.com)

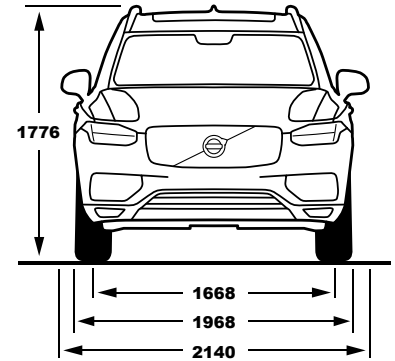
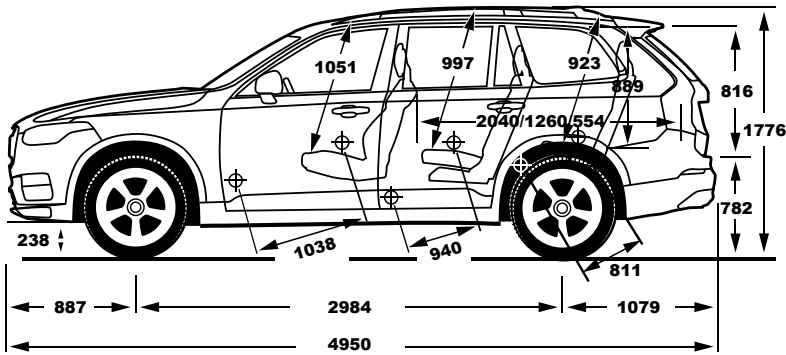

	T8 Twin Engine	T6 AWD
Engine type:	Plug-In Hybrid with 2.0 I4 petrol supercharged and turbocharged, and electric motor	2.0 I4 petrol supercharged and turbocharged
Transmission:	Eight-speed Geartronic®	Eight-speed Geartronic®
Fuel consumption, litres / 100km, mixed cycle, auto:	2.1	8.5
CO ₂ g/km, auto:	49	199
Max. power output:	235kW at 5700rpm + 65 kW at 7000rpm	235kW at 5700rpm
Max. torque:	400Nm at 2200-5400rpm + 240Nm at 0-3000rpm	400Nm at 2200-5400rpm
Acceleration, 0-100km/h in sec, auto:	5.6	6.5
Top speed, km/h, auto:	230	230
Fuel tank, litres:	50	71
Environmental classification:	Euro 6	Euro 6

Please note T8 Twin Engine figures shown are based on European testing. Please check with your Volvo dealer for the latest local information.

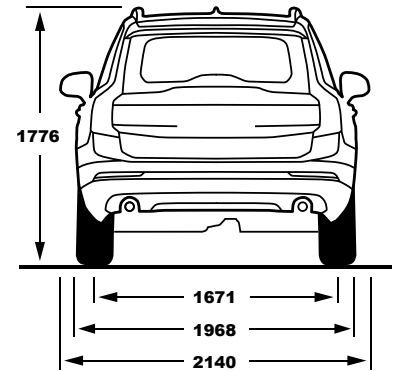
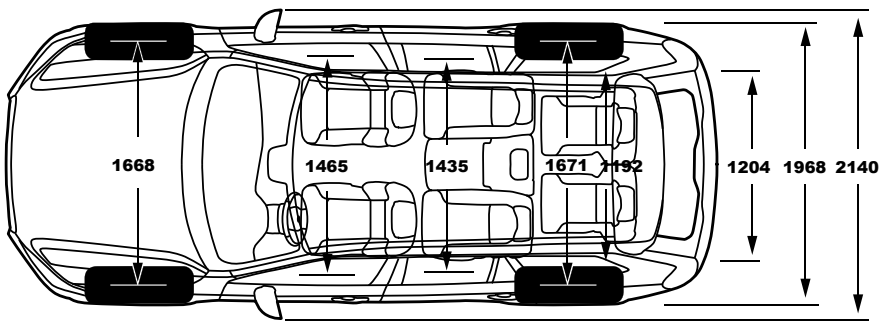

D5 AWD

Engine type:	2.0 I4 common-rail twin-turbodiesel
Transmission:	Eight-speed Geartronic®
Fuel consumption, litres/100km, mixed cycle, auto:	6.2
CO ₂ g/km, auto:	162
Max. Power output:	165kW at 4250rpm
Max. torque:	470Nm at 1750-2500rpm
Acceleration, 0-100km/h in sec, auto:	7.8
Top speed, km/h, auto:	220
Fuel tank, litres:	71
Environmental classification:	Euro 6

NB. The engine programme may vary from country to country. All technical data may be subject to change. Please talk to your Volvo dealer for the latest information.

Sensus options.

Sensus Connect comes with a host of features as standard: there's voice control, our High Performance audio system, an eye-catching 9-inch centre display with touchscreen and our 12-inch driver display. And if you'd like to enhance your experience, there's a wealth of options. For example,

you will be able to access selected apps and functions in your iPhone® via the centre display using Apple CarPlay. Then, there's Sensus Navigation and the head-up display: together, they make navigating easy and intuitive.

SENSUS

SENSUS CONNECT WITH HIGH PERFORMANCE AUDIO SYSTEM

Includes the following standard features:

- 12" driver display
- 9" centre display with touchscreen
- Bluetooth® audio streaming
- USB and AUX inputs
- Voice control
- Steering wheel controls

- Tethering via Wi-Fi or Bluetooth®
- High Performance audio system (330W, 10 speakers)
- Integration with Sensus Navigation
- Internet radio via apps

In addition, a digital owner's manual and connected service booking are included.

The following apps* will be standard:

- TuneIn
- Local Search
- Weather
- Send to Car

*More apps will be introduced later during 2015. For more information, please contact your Volvo dealer.

SENSUS CONNECT OPTIONS

In addition, the following options are available:

- Head-up display
- Apple CarPlay (for iPhone® 5 or later)
- High Performance subwoofer
- DAB+ (Digital Audio Broadcasting)
- CD player

PREMIUM SOUND BY BOWERS & WILKINS™

Our top-of-the-line audio system, developed exclusively for your XC90 together with the renowned high-end audio manufacturer Bowers & Wilkins™.

- 12-channel 1400 W Class D amplifier
- 19 Bowers & Wilkins™ speakers, including a subwoofer
- Quantum Logic Surround sound system
- Dirac Dimensions room transformation technology with three room modes: Concert, Studio and Stage
- Dirac Live sound-enhancement technology
- Stainless-steel tweeter panels

IntelliSafe options.

INTELLISAFE

Your Volvo XC90 comes with comprehensive IntelliSafe technologies as standard, which includes all the safety you'd expect from a Volvo and more. You'll also get City Safety, which encompasses technologies designed to help avoid collisions with pedestrians, cyclists and other cars. As a world-first, City Safety now also autobrakes if you're about to turn into the path of an oncoming car.

Add IntelliSafe Surround, and you'll get the benefit of technologies that alert you to vehicles approaching in your blind spot or from behind, providing an additional layer of safety. To round it off, the IntelliSafe Assist option supports your driving with Adaptive Cruise Control, Pilot Assist and Lane Keeping Aid.

INTELLISAFE STANDARD

Includes:

- Electronic Stability Control
- Roll Stability Control
- Driver Alert Control
- Road Sign Information
- Speed Limiter
- Lane Departure Warning
- Automatic braking after a collision
- City Safety
- Safety cage
- Safety belts with reminders and pretensioners for all seats
- Prepared front safety belts
- Airbags
- Run-off road protection
- Brake pedal release
- Whiplash Injury Protection System

INTELLISAFE SURROUND

Includes IntelliSafe Standard plus the following:

- Blind Spot Information
- Rear Collision Warning with braking at standstill
- Cross Traffic Alert

INTELLISAFE ASSIST

Includes IntelliSafe Standard plus the following:

- Adaptive Cruise Control
- Pilot Assist
- Distance Alert
- Lane Keeping Aid

INTELLISAFE DRIVER SUPPORT PACK

Driver assistance, convenience and IntelliSafe Assist features combined in a single pack including:

- 360° Camera
- Head-Up Display
- IntelliSafe Assist



The simplest way to own a car.

We love it when you're happy – when things are easier than you expect, or go faster and become better. Because when you buy a Volvo, you buy the simplest way to have a car. Financing, insurance, servicing, changing tyres, cleaning – those aspects of car ownership that you might not find very interesting are the ones that we love to make easier and better for you. That's why your

Volvo Car dealer will always offer you a whole range of simplifying services and offers all designed around you, giving you the most carefree ownership experience possible.

Still, this is just the beginning. Through our uniquely Swedish approach to innovation, we continuously find new ways to make your life simpler. For instance, the Connected Service Booking* function, which lets you book an

appointment just by pushing a button in your car. Or the new way of working in teams – like in a racing pitstop – that is gradually being introduced in Volvo Car workshops all over the world. We call it Volvo Personal Service, and it will make your workshop visits much shorter and more convenient.

BUYING & OWNING

- Warranties
- Financing
- Insurance
- My Volvo website

MAINTENANCE & SERVICES

- Volvo Genuine Service
- Volvo Professional Car Care

IF SOMETHING HAPPENS

- Volvo Roadside Assistance
- Repairs
- Volvo Glass Services
- Volvo Dent Repair
- Car Climate Services

MY VOLVO

My Volvo is a personalised website that contains everything you need to really get to know – and get the most out of – your car. It gives you:

- A complete overview of your Volvo Car ownership
- Easy access to all facts relating to your car
- Helpful tips regarding your specific Volvo model
- Instructional films and owner's manuals
- Online Service Booking
- Reminders regarding important stages of your car ownership
- Exclusive articles, films and photographs

CONNECTED SERVICE BOOKING*

If your Volvo has Sensus Connect, it will remind you when it needs servicing and offer to contact your Volvo Car dealer for you. Booking proposals sent from your preferred dealer can easily be managed directly in the car or on your personal My Volvo website. When the time comes to drive to your workshop, your Volvo will remind you and even guide you there. And since your Volvo tells us what it needs, we can make sure it always receives the service it requires when it gets there.

*Available depending on introduction date. Please contact your Volvo Car dealer

V O L V O