

ALL 4
THE BACK ROADS
THE SHORT CUTS
THE ESCAPE ROUTES
THE PATH LESS
TRAVELLED
THE OUTBACK DRIVER



OUTBACK | 2011

ALL 4 THE DRIVER™



SUBARU

ALL4 THE ESCAPE





IMAGE: OUTBACK 3.6R PREMIUM



ALL 4 THE DRIVER™

All 4 the Driver™ is far more than a simple phrase for those of us that work for Subaru. It's a philosophy that ensures a culture that's united in its passion for putting you, our customer, first.

Basically, it's about creating an extraordinary experience for you, each and every time. It means we have an uncompromising commitment to quality, especially in our dealings with you and how we make you feel. At Subaru we are all accountable for making All 4 the Driver a real experience for you. And we're all motivated by that challenge.

To find the Subaru that is right for you - don't take our word for it, Drive It Your Way®. After all, there's only one way to find out how a Subaru feels, and that's by getting behind the wheel. Put your favourite Subaru to the test on the kind of roads where you need it to perform most - from a quick, local dash around the block, to a longer freeway cruise, there's a test drive route to suit you. Ask your local Subaru Retailer for details.



Symmetrical All-Wheel Drive
Horizontally-opposed Boxer engine
Five-star ANCAP occupant safety

ALL 4 THE PERFORMANCE, THE SAFETY, THE RETAINED VALUE

Performance

Our Symmetrical All-Wheel Drive and horizontally-opposed Boxer engine technology have been developed to work together to provide superior handling, performance and balance - which gives our Drivers greater confidence. Confidence that makes for pure driving pleasure.

Safety

Thanks to its uniquely balanced design, every Subaru is made to grip the road in just about any condition. A ring-shaped passenger safety cell and advanced crumple zone technology help protect Subaru Drivers and passengers from serious injuries. It's part of the reason every Subaru is awarded a five-star ANCAP occupant safety rating – the highest occupant safety rating available in Australia – ensuring a worry-free trip, wherever you're heading.

Retained Value

Excellent retained value is no accident. Subaru starts with outstanding cars, adds world famous advanced driving technologies and provides every owner with maximum five-star occupant safety. But it doesn't end there. Our highly skilled service technicians at over 100 Subaru service centres around Australia ensure your Subaru is kept in peak condition at all times. Subaru has had an active focus on the retained value of all our models for many years. This is the result of delivering exceptional performance, safety technologies and DataDot™ theft protection to ensure that owning a Subaru is a good investment.



THE
DIFFERENCE
IS OUR
DNA



ALL OF THIS ADDS UP TO A BETTER EXPERIENCE FOR THE DRIVER.

ALL 4 THE MUD THE SWEAT THE CHEERS THE SUBARU DRIVER



Rallying has always been a brutally tough motorsport. With uncompromising terrain, wildly fluctuating conditions, and constant demands on the cars, it's one of the most challenging sports in the world – and a perfect testing ground for Subaru. We were part of the World Rally Championship for 19 years – and while we were fine-tuning our unique technologies, we were also winning championships. We won the World Rally Championship Manufacturers' title three times, and the driver's title three times as well.

And our decade of dominance in the Australian Rally Championship – from 1996 to 2005 – is a testament not only to our ongoing passion for innovative design and engineering, but our unique understanding of Australian driving conditions. It's a passion that flows through our earliest designs and drawings, into our race-bred testing regime, and into the car you drive.

Pioneering performance since 1958

From the introduction of the Subaru 360 in 1958 to Subaru's three consecutive World Rally Championship (WRC) Manufacturers' titles from 1995 to 1997, Subaru has a long history of engineering and motor sports achievement. Here's a quick look at the Subaru journey...



AUSTRALIAN
MANUFACTURERS'
CHAMPION



AUSTRALIAN RALLY DRIVER'S
CHAMPIONSHIP

ALL 4 THE SUBARU HERITAGE

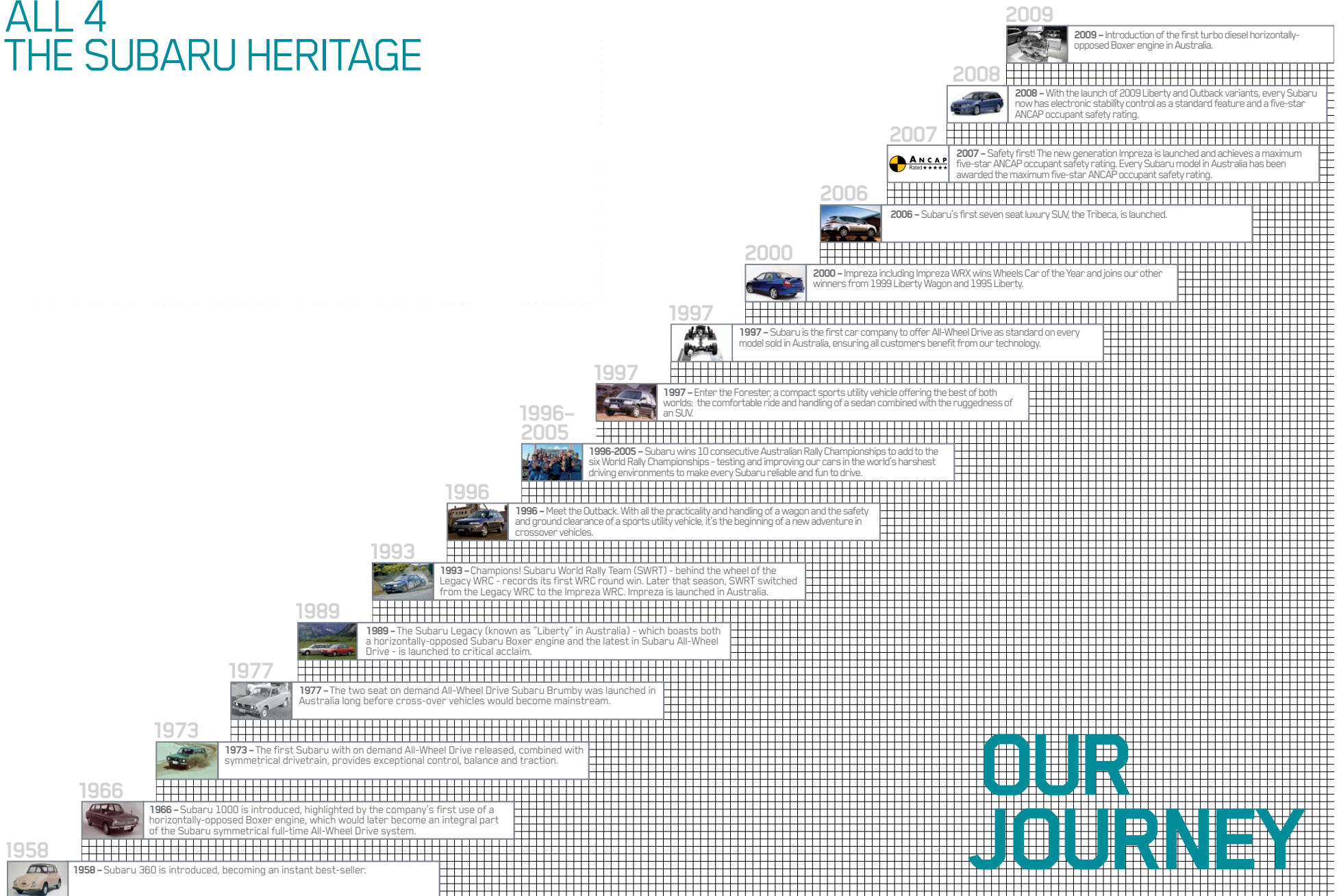

OUR JOURNEY





ALL 4 THE ESCAPE THE EVERYDAY ANYDAY

Confidence

It reveals itself in the corners. In the wet. In the moments when it really counts. It's the same confidence that turns an everyday drive into an exhilarating ride. That's why we've made driver confidence the cornerstone of everything we do at Subaru. Every innovation, every technological advancement, every intricate detail in a Subaru is there to inspire confidence. And give you a more enjoyable drive, whatever road you're travelling on.

Just pack up and go

Wherever you want. Whenever you want. Getting away from it all at a moment's notice is one of life's simplest pleasures. All you need is a spirit of adventure, and a car rugged, robust and durable enough to take you where you want to go. We've designed the Subaru Outback to be that car.

With its sure-footed, wide-body design and the balance and control of Subaru's Symmetrical All-Wheel Drive and Vehicle Dynamics Control system, the Outback will allow you to take on challenging conditions with confidence. And its sophisticated styling cues, technological advancements and luxurious appointments mean it's as at home in the city as the bush. So you can live more adventurously, every day.

IMAGE: OUTBACK 3.6R PREMIUM

ALL 4 THE FEELING ON THE INSIDE

Taking on the great outdoors needn't mean roughing it. In fact, whenever you get away in your Outback, you'll do it in luxury. From dual-zone climate control air-conditioning, to power windows and mirrors, every element of the Outback's stylish interior has been designed around comfort. And the most luxurious appointment of all?

Space. Everyone – especially those in the back – will find big trips a breeze, with room to spread out and get comfy. As for the driver, you'll also notice that while you've got plenty of room, everything's within easy reach – so you never have to concentrate on anything other than the road.



IMAGE: OUTBACK 2.5i PREMIUM WITH OPTIONAL SATELLITE NAVIGATION



25°C 82 mi 12:00

P 00 00008

0 20 40 60 80 100 120 140 160 180 200 220 km/h



SRS AIRBAG

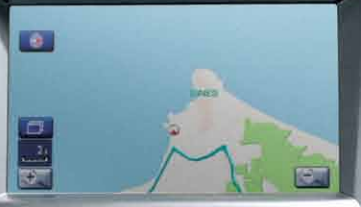

DVD player and radio controls including buttons for SEEK, AUTO, SCAN, and DISP, along with a digital display showing 25.0 and 23.5.



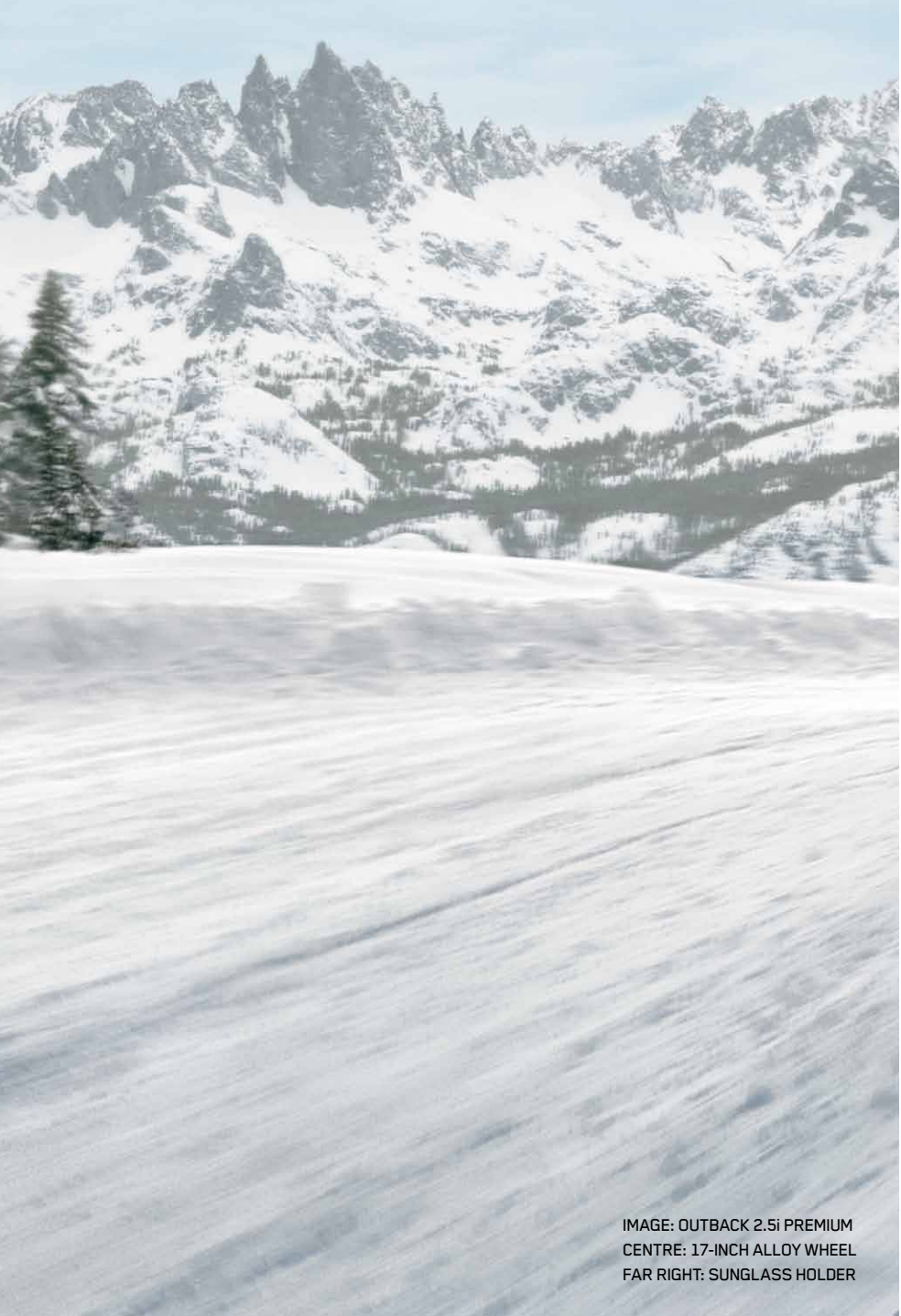

We've taken all the experience and knowledge that comes with producing the original crossover vehicle, and delivered it with refined style and intelligent features. And under the bonnet, a 2.5-litre Boxer engine capable of producing 123kW of power, and 229Nm of torque, is matched by the balance of Subaru's Symmetrical All-Wheel Drive system and the added safety of Vehicle Dynamics Control.

The Outback 2.5i also features a six-stack in-dash CD player with auxiliary jack¹, dual-zone climate control air-conditioning, electronic park brake, power windows and mirrors, *Bluetooth*[®] wireless technology² and rear privacy glass. Plus, 17-inch alloy wheels, the ease of hill holder and the option of a six-speed manual or Lineartronic™ CVT.

And of course, the added safety of seven SRS³ airbags, including dual front, front side, curtain and driver's knee protection.

Take the Outback 2.5i Premium, and you'll enjoy an electric sunroof and the extra comfort of leather⁴ seats including an eight-way power driver's seat with dual memory and lumbar support.

You also have the option of an eight-inch touch screen in-dash satellite navigation system with *Bluetooth*[®] wireless technology², voice recognition, a single CD/DVD⁵ player with six speakers, RCA jacks⁶ and rear view reverse camera.

OUTBACK 2.5i AND OUTBACK 2.5i PREMIUM

ALL 4
THE VERSATILITY
THE FEATURES
THE STYLE
THE DRIVER

1. Auxiliary jack not available if satellite navigation is fitted.
 2. *Bluetooth*[®] is a registered trademark of Bluetooth SIG Inc. System operation ability is subject to the *Bluetooth*[®] wireless technology specification of individual's phone.
 3. SRS: Supplemental Restraint System. Effective when used in conjunction with seatbelts.
 4. Some parts of seating are not full natural leather.
 5. DVD only operates when vehicle is stationary.
 6. RCA jacks replace auxiliary jack when satellite navigation is fitted.



IMAGE: OUTBACK 2.5i PREMIUM
 CENTRE: 17-INCH ALLOY WHEEL
 FAR RIGHT: SUNGLASS HOLDER

OUTBACK 3.6R AND OUTBACK 3.6R PREMIUM

An adventurous crossover vehicle with sophistication and elegance. The luxurious, six-cylinder Outback is smooth and powerful with a host of intelligent technologies – to take you anywhere in style. The 191kW 3.6-litre Subaru Boxer engine gives you power on tap, and enough torque to shoulder even the biggest loads.

A five-speed automatic transmission delivers smooth acceleration, whilst the Vehicle Dynamics Control and seven SRS¹ airbags help make every drive a safe one. As intelligent as it is powerful, the Outback 3.6R features include SI-DRIVE, a push-start ignition with smart key, as well as rain sensing wipers, and dusk sensing headlights.

The Outback 3.6R Premium adds leather² seats and electric sunroof along with the superior sound of a 10-speaker McIntosh entertainment system with built in satellite navigation. It features *Bluetooth*³ wireless technology³, voice recognition, a single CD/DVD⁴ player, RCA jacks⁵ and rear view reverse camera.

ALL 4
THE LUXURY
THE ELEGANCE
THE ADVENTURE
THE DRIVER

1. SRS: Supplemental Restraint System. Effective when used in conjunction with seatbelts.
2. Some parts of seating are not full natural leather.
3. *Bluetooth*[®] is a registered trademark of Bluetooth SIG Inc. System operation ability is subject to the *Bluetooth*[®] wireless technology specification of individual's phone.
4. DVD only operates when vehicle is stationary.
5. RCA jacks replace auxiliary jack when satellite navigation is fitted.

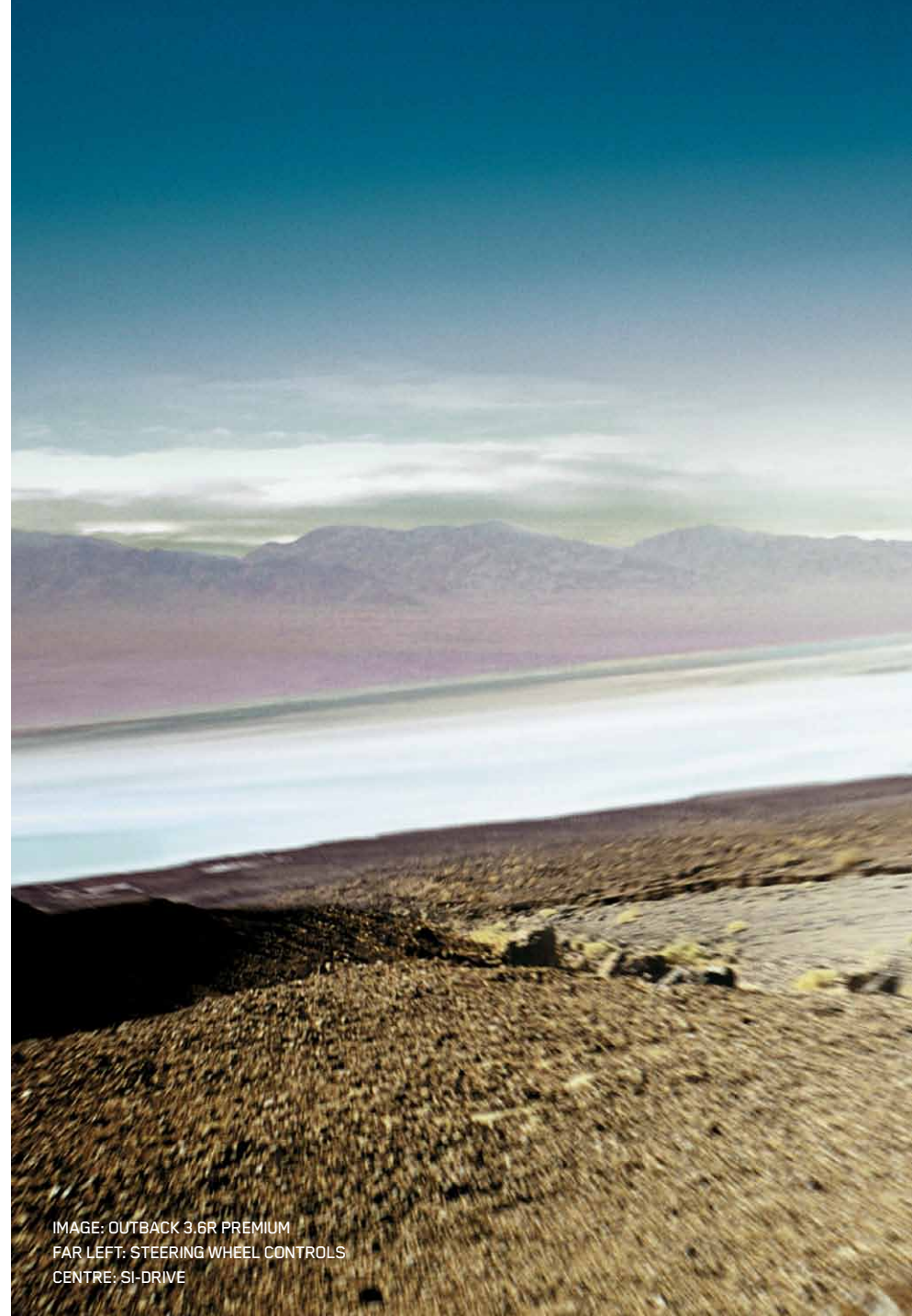

IMAGE: OUTBACK 3.6R PREMIUM
FAR LEFT: STEERING WHEEL CONTROLS
CENTRE: SI-DRIVE



OUTBACK 2.0D AND OUTBACK 2.0D PREMIUM

All the style. All the substance. The Subaru Outback 2.0 Diesel gives you the flexibility Outback has always represented, but with the ability to go over 1000km¹ on a single tank and meets the EURO5 emissions standards.

Powered by a 2.0-litre turbocharged Boxer Diesel engine and a six-speed manual transmission, with Vehicle Dynamics Control and the balance of Subaru's Symmetrical All-Wheel Drive system – the Outback 2.0 Diesel cuts down on fuel, while losing none of the adventure.

Sharing the features of the Outback 2.5i, you'll find the Outback 2.0 Diesel packed with intelligent features like a six-stack in-dash CD player with auxiliary jack², dual-zone climate control air-conditioning, electronic park brake, power windows and mirrors,

Bluetooth[®] wireless technology³ and rear privacy glass. Plus, 17-inch alloy wheels and the ease of hill holder. And of course, the added safety of seven SRS⁴ airbags, including dual front, front side, curtain and driver's knee protection.

Choose the Outback 2.0 Diesel Premium and you'll also enjoy an electric sunroof and the extra comfort of leather⁵ seats including an eight-way power driver's seat with dual memory and lumbar support. And you also have the option of an eight-inch touch screen in-dash satellite navigation system with *Bluetooth*[®] wireless technology³, voice recognition, a single CD/DVD⁶ player with six speakers, RCA jacks⁷ and rear view reverse camera.

ALL 4
THE ECONOMY
THE LONG RUN
THE DIESEL
THE DRIVER

1. Based on a highway cycle of 5.6L per 100km and fuel capacity of 65L tested in accordance with ADR81/02.
2. Auxiliary jack not available if satellite navigation is fitted.
3. *Bluetooth*[®] is a registered trademark of Bluetooth SIG Inc. System operation ability is subject to the *Bluetooth*[®] wireless technology specification of individual's phone.
4. SRS: Supplemental Restraint System. Effective when used in conjunction with seatbelts.
5. Some parts of seating are not full natural leather.
6. DVD only operates when vehicle is stationary.
7. RCA jacks replace auxiliary jack when satellite navigation is fitted.



IMAGE: OUTBACK 2.0 DIESEL PREMIUM
FAR LEFT: OPTIONAL SATELLITE NAVIGATION SYSTEM
CENTRE: 17-INCH ALLOY WHEEL



ALL OR NOTHING

We pioneered Symmetrical All-Wheel Drive (SAWD) over 30 years ago and it remains one of our defining achievements. The combination of SAWD and the Traction Control System incorporated within the Subaru Vehicle Dynamics Control system (VDC) optimises tyre traction

and provides the driver with outstanding control. Partnered with our horizontally-opposed Boxer engine, and symmetrical drivetrain, it gives you a sense of poise and balance that not only inspires confidence, but delivers optimum safety – whatever the conditions.



The benefit of symmetry

The drivetrain of your Subaru is perfectly symmetrical with the engine, transmission, propeller shaft and rear differential all arranged in a straight line.

The result is ideal weight distribution, a low centre of gravity, and perfect balance giving you sure-footed control, and smooth, receptive handling.

Three distinctive advantages

1. Better balance

A low centre of gravity means less body roll, flatter cornering and improved response with the benefits of SAWD grip.

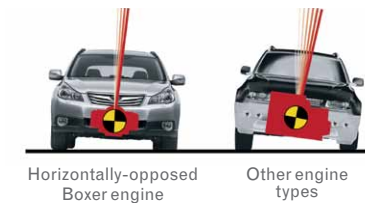

2. Less vibration

Our horizontally-opposed Boxer engines are flat in shape and sit low in the engine bay, meaning less vibration, noise and greater cabin comfort.

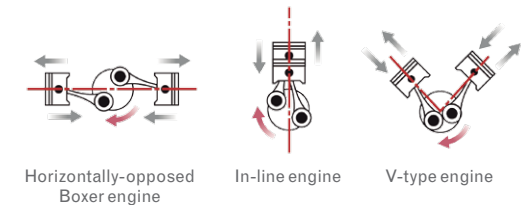

3. More grip and traction

SAWD offers distinct advantages over two-wheel drives when cornering by optimising traction and reducing the likelihood of oversteer or understeer.



Transfers power from the wheels that slip to those with grip

Sure-footed control

The sense of control you feel behind the wheel owes a lot to our intelligent chassis design and finely tuned suspension. The light but rigid materials in the chassis give the car extra agility, and the

McPherson strut-type independent front suspension, a double wishbone rear suspension and speed sensitive power-assisted steering combine to provide a smooth, controlled ride, with lots of road-holding grip.

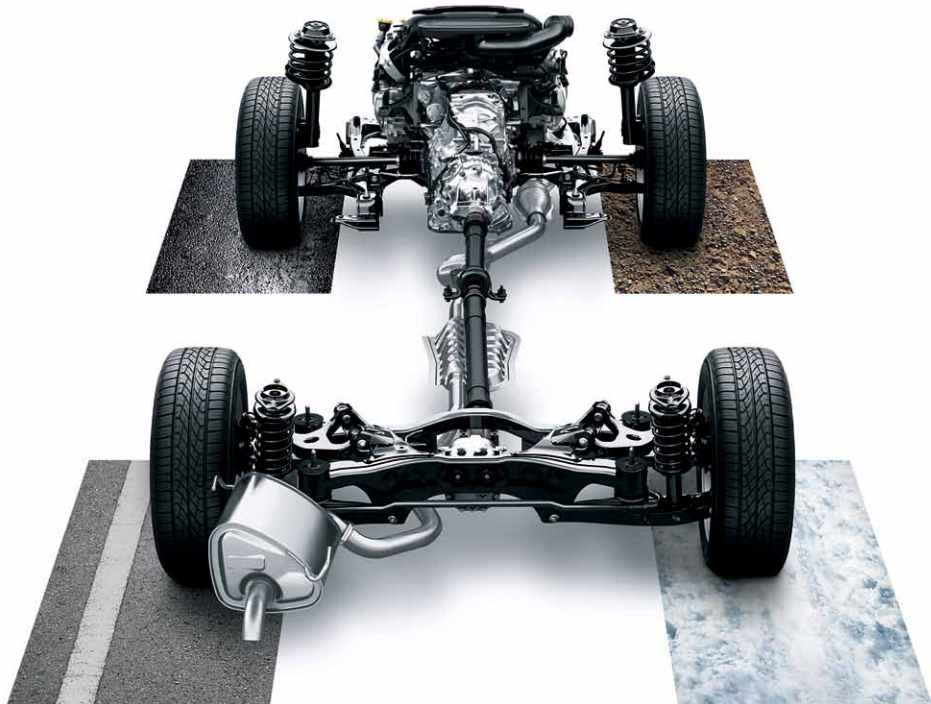

Front suspension

A wide track rigid front suspension produces more responsive steering and stable cornering, optimising tyre contact with the road surface.



Rear suspension

Self-levelling double wishbone rear suspension ensures a consistent ride height, and adjusts automatically depending on the cargo load. This ensures maximum tyre contact with the road – delivering a smooth, controlled ride with outstanding handling, comfort and quietness.



ALL 4 THE EXHILARATION

You feel the difference on your very first drive. That quiet, smooth acceleration and light-footed responsiveness that has become the hallmark of the horizontally-opposed Subaru Boxer engine. Tuned for mid-range torque as well as top-end power, it offers the driver impressive performance – even when carrying a big load.

ACTIVE CONTROL

The Outback 3.6-litre DOHC six-cylinder engine features our Dual Active Valve Control System (DAVCS) which varies inlet and exhaust camshaft timing, improving fuel economy, power and torque.

INTELLIGENT TIMING

The Outback 2.5-litre SOHC engine utilises our intelligent Active Valve Lift System (i-AVLS). i-AVLS varies the inlet valve lift and timing to improve fuel efficiency, power and low speed torque.



SUBARU 2.5-LITRE FOUR-CYLINDER SOHC BOXER ENGINE



Max. power: 123kW @ 5,600rpm
Max. torque: 229Nm @ 4,000rpm

The 2.5-litre naturally aspirated engine delivers 123kW of power at 5,600rpm; and provides the towing capability of 229Nm of torque at 4,000rpm.

That translates to an even, well-balanced drive, with strong torque performance in both low and high rev ranges. Fuel economy is impressive with only 8.4¹ litres required per 100km giving you extended range with lower emissions.

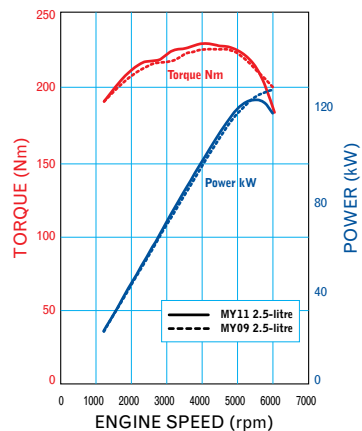

SUBARU 3.6-LITRE SIX-CYLINDER DOHC BOXER ENGINE



Max. power: 191kW @ 5,600rpm
Max. torque: 350Nm @ 4,400rpm

The powerful, 3.6-litre horizontally-opposed Boxer engine produces an impressive 191kW of power at 5,600rpm. And it can carry a load too – with 350Nm of pulling power at 4,400rpm.

The torque curve shows the engine's consistent pulling ability throughout the rev range, while the power curve demonstrates a smooth, linear delivery from very low to high revs – giving you the ideal combination of drivability and performance.

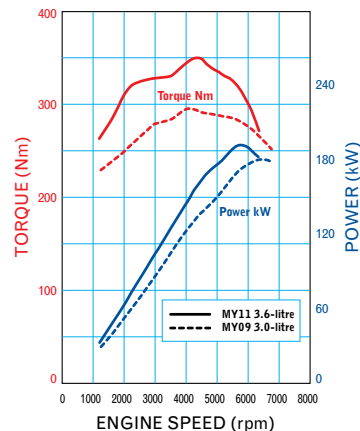

SUBARU 2.0-LITRE FOUR-CYLINDER DOHC TURBOCHARGED BOXER DIESEL ENGINE



Max. power: 110kW @ 3,600rpm
Max. torque: 350Nm @ 1,800-2,400rpm

Subaru's Boxer Diesel engine delivers 110kW of power at 3,600rpm and 350Nm of torque between 1,800 and 2,400rpm.

Common rail fuel injection, turbocharging, double overhead camshafts and an intercooler mark this engine as state-of-the-art. With outstanding fuel economy, extraordinary driving range and strong pulling power, our Boxer Diesel engine produces a drive that's lively and efficient.

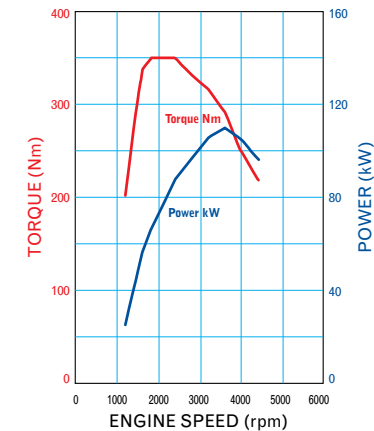

1. Based on Lineartronic™ CVT model tested in accordance with the ADR81/02 'combined cycle' test.

ALL 4 THE PERFORMANCE

Manual transmission

The six-speed manual transmission available on selected Outback models has been specifically developed to deliver improved driveability, and a quieter, more fuel efficient ride.

The six-speed's wider gear ratio spread translates to faster acceleration in the lower gears, and improved fuel consumption—for an all-round stronger performance.



Automatic transmission

Lineartronic™ CVT:

The 2.5-litre naturally aspirated Outback range features an innovation called Lineartronic™ Continuously Variable Transmission (CVT) – Subaru's first longitudinally mounted CVT system for an All-Wheel Drive production vehicle. What makes it so special is that unlike conventional automatics – which use fixed gear ratios – the CVT gives you smooth acceleration with no discernible steps or shifts.

Five-speed automatic:

You'll find the five-speed automatic transmission in the Outback 3.6R and the Outback 3.6R Premium models. It utilises a Variable Torque Distribution (VTD) centre differential that sets a drive split of 45 percent / 55 percent front to rear to ensure greater balance and control. The five-speed automatic transmission can be driven in full automatic mode or manual mode using the paddle gear shift on the steering column, and also interacts with SI-DRIVE to tailor the gear changes and responsiveness of the vehicle to the driver's needs.



Always in the right gear

All automatic transmissions come with Adaptive Control¹ featuring Hill Climb Control, Sudden Accelerator Release Control, Braking Control and Cornering Control – that give you greater confidence in a range of different driving situations.

The selectable manual mode of the automatic transmissions allows you to 'shift' manually using steering wheel paddle controls. When in drive, you can engage manual mode simply by moving the gear selector towards you, or engage temporary manual mode immediately by using the steering wheel paddle controls.

1. Only applies to five-speed automatic in S# mode and Lineartronic™ CVT.

THREE DRIVES, ONE CAR



Every drive's different. From the trip to work, to the highway cruise, to the path less travelled, you'll always face different conditions, and place different demands on the car. That's why we developed Subaru Intelligent Drive (SI-DRIVE)

– giving you three driving modes to match every challenge you experience on the road. SI-DRIVE regulates the engine control unit, the electronic throttle and the transmission control unit and is standard in Outback 3.6R models.

1. Intelligent (I) mode

Intelligent mode gives you a well-balanced, economical performance, with smooth throttle control and optimum fuel efficiency when combined with sensible driving. It's ideal for the daily commute to work, freeway driving and in heavy traffic – where power isn't essential.



2. Sport (S) mode

Sport mode's linear acceleration turns an everyday drive into an exhilarating experience – with heightened acceleration and sporty all-round performance.



3. Sport Sharp (S#) mode

For the true driving enthusiast. Sport Sharp mode significantly boosts responsiveness with even the lightest touch on the throttle. Gearshift timing is set at higher engine speeds for thrilling performance.





SAFETY FIRST SECOND AND THIRD

FIRST – BALANCE

Symmetrical All-Wheel Drive (SAWD) is an integral part of the Subaru driving experience. SAWD enhances control by taking advantage of the traction offered by all four tyres distributing power. Which means driving on low friction surfaces like wet or snowy roads and muddy tracks becomes much safer.

SECOND – STABILITY

All Outbacks come standard with a high level of collision avoidance technologies – an electronic driver assist system called Vehicle Dynamics Control (VDC). This is not just Electronic Stability Control (ESC) but a complete system of safety measures.

Subaru's VDC system is made up of both stability and braking technologies:

- Electronic Stability Control (ESC)
- Traction Control System (TCS)
- TCS Limited Slip Device (LSD)
- Anti-Lock Braking System (ABS)
- Electronic Brakeforce Distribution (EBD)
- Brake Assist

So in extreme situations – like when you have to swerve or brake suddenly – VDC is there to help. The VDC system is constantly analysing through an array of sensors, the parameters that affect vehicle stability of the Outback whilst it's in motion.

Understeer or oversteer challenge even the best of drivers. The ESC technology incorporated within the VDC system aids the driver in maintaining control during cornering and emergency manoeuvres. When the road conditions are particularly challenging such as a muddy track the VDC Traction Control System and TCS Limited Slip Device kick in, minimising wheel spin and transferring power from the wheels that slip to the wheels with grip.

The Anti-lock Braking System (ABS) – including Electronic Brakeforce Distribution (EBD) and Brake Assist work together to help avoid wheels locking up, maximise stopping power and make sure the right amount of braking force is applied in an emergency. Every centimetre makes a difference. Put simply, all these features work together to give you control when you need it the most.

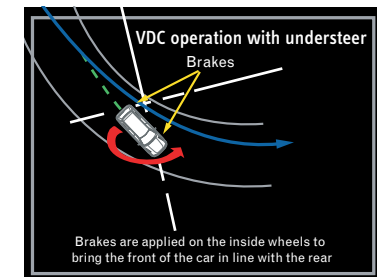
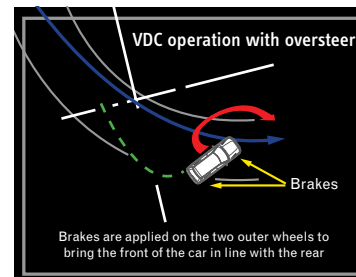
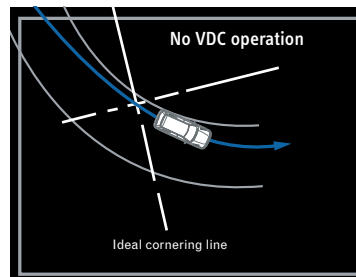

THIRD – PROTECTION

Five-star safety...

Every occupant can feel that much safer knowing the Outback has been awarded the maximum five-star crashworthiness rating for occupant safety from the respected and independent Australasian New Car Assessment Program (ANCAP)¹.

Such a high safety rating has a lot to do with the innovative advancements that we've made an integral part of the Outback. Advancements like the high-strength front seat frames and energy absorbing headrests that provide enhanced protection against whiplash in heavy rear-end collisions. All rear seatbelts come with Automatic Emergency Locking Retractors, and the front seatbelts feature pretensioners that hold you securely in place in an accident.

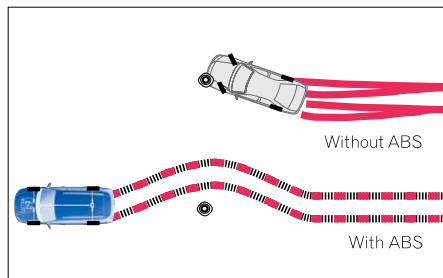

... That's tough on the outside...

The Outback's ring-shaped passenger safety cell is made to absorb impact – and features steel reinforcements, crumple zones and a strong, rigid build designed to help reduce injury in the event of an accident.

The chance of serious injury to the front occupants is further reduced by the ingenious positioning of the engine – low enough to slide below the cabin in a severe frontal collision. Plus the energy-absorbing collapsible steering column, and pedal intrusion limiting system help minimise driver injuries in a heavy frontal collision.

... And soft on the inside

Seven SRS² airbags help protect passengers from a heavy impact. Dual front, front side, curtain and driver's knee airbags come standard in all Outback models.

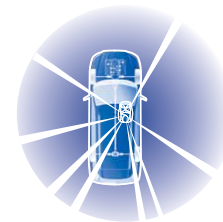

A grand vision

Subaru design engineers take special care to optimise your field of vision from the driver's seat, without compromising the protection of all your occupants. The result is a strong passenger compartment, with outstanding visibility – helping you to avoid accidents in the first place.

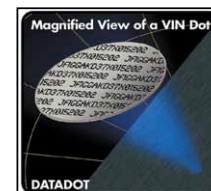

Did you know?

All Subaru Outback models are fitted with advanced engine immobilisers and DataDot™ technology. Approximately 7,000 microscopic dots are laser-etched with your vehicle's unique Vehicle Identification Number – making your Subaru a much less attractive target for potential thieves.

1. The Australasian New Car Assessment Program (ANCAP) gives consumers consistent information on the level of occupant protection provided by vehicles in serious front and side crashes.
2. SRS: Supplemental Restraint System. Effective when used in conjunction with seatbelts.

ALL 4 THE ENTERTAINMENT

Entertainment

Wherever your adventures take you, you'll always be accompanied by the perfect soundtrack. There are a variety of audio systems across the Outback range to make the most of any road trip. And the best part is, it's all at your fingertips, with audio controls right there on the leather steering wheel.

Bluetooth® wireless technology¹

The Outback range features Bluetooth® wireless technology¹ giving you hands-free calling from your mobile phone so you are always in touch (operation ability is subject to Bluetooth® specification of individual phone).

Satellite navigation

The Outback 2.5i Premium and Outback 2.0 Diesel Premium with optional satellite navigation system, comes with a high definition, eight-inch VGA monitor showing you the best way home (thanks to the renowned Whereis™² Map database). A single CD/DVD³ player with MP3/WMA/iPod⁴ compatibility pumps out your soundtrack of choice with DOLBY PRO LOGIC sound through six speakers. It also features voice recognition, RCA jacks⁵ and a rear view reverse camera.

Standard audio

With six speakers, and a six-stack CD player that's MP3/WMA and iPod⁴ compatible, our standard audio system (available in the Outback 2.5i, Outback 2.5i Premium, Outback 3.6R, Outback 2.0D and Outback 2.0D Premium) is anything but standard. Door speakers and tweeter position ensure rich sound all through the cabin and an auxiliary jack⁶ means you can always listen to your favourite playlist on your iPod⁴.

McIntosh entertainment system with satellite navigation

The Outback 3.6R Premium features a superior McIntosh entertainment system – for the ultimate in sound quality. You'll enjoy the incomparable, cabin-filling sound of 10 speakers – including a subwoofer, large tweeters and a separate amplifier – delivering your driving soundtrack from the single CD/DVD³ player with MP3/WMA/iPod⁴ compatibility. The McIntosh system also includes satellite navigation, voice recognition, RCA jacks⁵ and a rear view reverse camera.

1. Bluetooth® is a registered trademark of Bluetooth SIG Inc. System operation ability is subject to the Bluetooth® wireless technology specification of individual's phone. 2. Whereis is a registered trademark of Telstra Corporation Limited. 3. DVD only operates when vehicle is stationary. 4. iPod is a registered trademark of Apple Computer, Inc. 5. RCA jacks replace auxiliary jack when satellite navigation is fitted. 6. Auxiliary jack not available if satellite navigation is fitted.



Satellite navigation system



McIntosh entertainment system with satellite navigation

WATCH THIS SPACE



The Outback doesn't just give your passengers the ability to spread out, it also offers plenty of room for all your belongings. And whether you're packing for a long weekend, or just trying to pack in all the groceries, the Outback's large, wide-body design makes fitting everything in that much easier.

Remote keyless entry means you can unlock the car with a handful, and the retractable cargo security blind means you'll be the only one who knows what's stowed on board. Easy-to-use release levers in the cargo area also allow you to instantly fold down the rear seats for an extra-large load.

A place for everything

The Outback gives you the storage facilities for all of life's little knickknacks:

- Centre console cup holders with lid
- Moulded door pockets with bottle holders
- Seat back pocket nets
- Sunglass holder
- Front centre tray

Outback 3.6R Premium ivory interior shown



Retractable cargo blind



Centre console cup holders with lid



Rear seat cup holders



Sunglass holder



Seat back pocket nets



Moulded door pockets with bottle holders

THE OUTBACK RANGE

OUTBACK 2.5i



OUTBACK 2.5i PREMIUM

Optional satellite navigation also available



Outback 2.5i Premium with optional satellite navigation shown

OUTBACK 3.6R



OUTBACK 3.6R PREMIUM



THE OUTBACK RANGE

OUTBACK 2.0D



OUTBACK 2.0D PREMIUM

Optional satellite navigation also available



Outback 2.0D Premium with optional satellite navigation shown

ALL 4 THE HUE THAT'S... YOU

One of the final choices – but one of the most important! The colour you choose for your Outback makes a bold statement about who you are.

So we've made sure you've got lots of ways to express yourself – with a wide range of colours to make your Outback more... you.



Note: Paint colours are representative only and subject to variation due to the printing process.

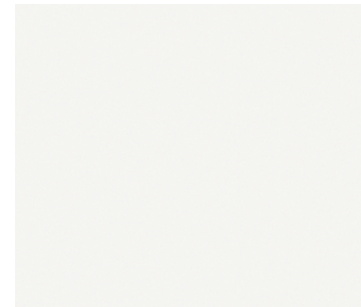

Satin white pearl

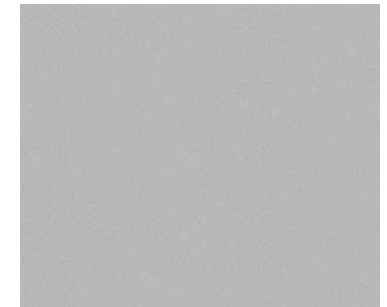

Steel silver metallic

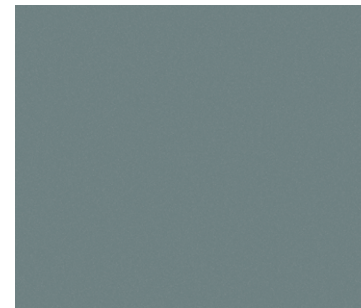

Sage green metallic

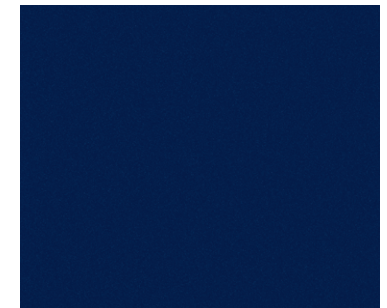

Galaxy blue silica



Graphite grey metallic

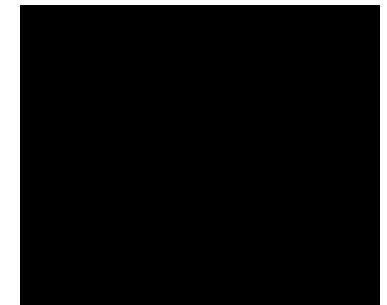

Crystal black silica



Camellia red pearl



Sunlight gold opal

MAKE A GENUINE DIFFERENCE

Subaru Genuine Accessories

The small things can sometimes make the biggest difference. So to set your Subaru apart, personalise it with any of our Subaru Genuine Accessories. From the added protection of carpet mats and cargo trays, to towing and adventure packed roof carrying systems, we have a great range of accessories to help you get your Subaru just right for your lifestyle. You can see the complete range of accessories at subaru.com.au

Genuine accessories

Genuine warranty

All Subaru Genuine Accessories come with a manufacturer's warranty:

- When you have them fitted at the time you purchase your new vehicle (or at your first scheduled service by your Subaru Retailer) you get a three-year/unlimited-kilometre warranty.

- When you purchase accessories and have them fitted by your Subaru Retailer any other time you get a two-year/unlimited-kilometre warranty.
- When you purchase accessories from your Subaru Retailer at any other time, you get 12-month/unlimited kilometre warranty.

You can get full warranty information at subaru.com.au



Roof cross bars



Universal locking arm¹



Bicycle holder upright¹



Atlantis 780 luggage pod¹ - large



Bonnet protector²



Headlight protector³



Rubber floor mat



Carpet floor mat

1. Roof cross bars required. 2. Not suitable for Outback 2.0 Diesel. 3. Not suitable for HID headlights.

**ALL 4
THE LIFESTYLE
THE PERSONALISING
THE ACCESSORISING
THE OUTBACK DRIVER**



Outback 2.5i Premium shown with bonnet protector, headlight protectors, fog light protectors and door visors.



Cargo tray



Cargo step panel



Towbar



Door visor



Fog light protector



iPod¹ cable²



AVN satellite navigation³



Puddle lamps

1. iPod is a registered trademark of Apple Computer, Inc. 2. iPod not included. Suitable for vehicles with factory fitted satellite navigation. 3. Suitable for all models without factory fitted satellite navigation.

ON THE ROAD TO TOMORROW



The maker of Subaru vehicles, Fuji Heavy Industries (FHI), understands the importance of environmental responsibility in all its business activities and services. And in keeping with its goal of being “an intelligent company that is friendly to the global environment” it’s constantly looking for ways to be more environmentally considerate – even in ways that reach beyond the automotive manufacturing sector of its business.

FHI has bettered its carbon dioxide emission reduction targets, thanks to their commitment to energy conserving programs at their factories and other facilities, including the introduction of natural gas-fuelled cogeneration facilities. It also strives to reduce CO₂ emissions in its non-automotive areas, producing fuel-efficient general use engines and wind turbine electric power generation systems.

And at the forefront of all this is their environmentally responsible manufacturing of Subaru vehicles, right across the world. For instance in North America, Subaru was the first automotive manufacturer to receive the stringent ISO 14001 environmental management standard. As well as being the first to achieve zero landfill status.

Since then, Subaru has achieved ISO 14001 accreditation across its entire Japanese business, and continues to find new ways to minimise its impact on the world we all call home.

(Source: Fuji Heavy Industries 2007 Social and Environmental Report)

SUBARU SERVICES

For more information about the Subaru Services listed below visit subaru.com.au

SUBARU FINANCE

Subaru Finance allows you to explore a range of tailored finance options through your authorised Subaru Retailer – so that approved customers can finalise purchase details quickly and conveniently. As dedicated automotive finance specialists, we can offer a range of private and business packages, including vehicle loans, leasing and commercial hire purchase finance.

SUBARU INSURANCE

We understand that you, as a Subaru owner, want a range of insurance options that offers features and benefits that complement your Subaru vehicle. Subaru Insurance options include:

- Subaru Comprehensive Motor Vehicle Insurance
- Subaru Motor Equity Insurance
- Subaru Loan Protection Insurance

These Subaru Insurance products are available only through participating authorised Subaru Retailers.

SUBARU SME LEASING SOLUTIONS

Tailored specifically for small to medium businesses, Subaru SME Leasing Solutions allows your business to explore a range of operating lease solutions through your authorised Subaru Retailer, so that approved customers can enjoy the benefits a true fleet management company can provide. Subaru SME Leasing Solutions offers a range of business packages, including operating leasing and a full range of fleet management services.

SUBARU PREFERRED COLLISION REPAIRER NETWORK

Subaru has appointed a network of Preferred Collision Repairers, with stringent quality standards and high customer service levels. Our dedicated helpline is available on 1800 737 179, 24-hours a day, seven days a week.

SUBARU SERVICE AND SUBARU GENUINE CARE

Inherent within every Subaru is a philosophy of engineering excellence, award-winning performance and advanced driving technology. Subaru Genuine Care delivers the technical expertise, specialist diagnostic equipment and genuine replacement parts required to keep your Subaru in optimum condition. There is also the advantage of knowing your vehicle is maintained by factory-trained technicians with unequalled knowledge of Subaru products.

SUBARU LIFESTYLE

The philosophy of building motor vehicles that perform to the highest standards extends to our range of quality merchandise. With a diverse collection of stylish apparel and accessories, there is something to appeal to every Subaru enthusiast. To see the entire Subaru merchandise range, visit shop.subaru.com.au, or ask your local authorised Subaru Retailer.

SUBARU ROADSIDE ASSIST

In the unlikely event your Subaru breaks down or experiences technical problems, Subaru Roadside Assist is available 24-hours a day, seven days a week to help customers at a competitive annual fee starting from \$71.50*. For more information on Roadside Assist, ask your local authorised Subaru Retailer.

*Prices subject to change without notice.

SUBARU ASSURED WARRANTY PROGRAM FOR USED VEHICLES

Qualifying used Subaru vehicles from participating Subaru Assured Retailers offer a two-year unlimited kilometre warranty extension to further complement either the balance of a new vehicle or the statutory warranty that remains. Every used Subaru Assured vehicle must pass a 116-point inspection.

OUTBACK AWARDS

- 2009 • Australia's Best Cars, Best Recreational 4WD, Subaru Outback 2.5i
- Fairfax Drive Car of the Year 2009, Best SUV under \$40,000, Subaru Outback
 - Australasian New Car Assessment Program (ANCAP)
five-star occupant safety rating for the entire Outback range

subaru.com.au

Subaru (Aust) Pty Limited ABN 95 000 312 792 (Subaru Australia)
Level 3, 4 Burbank Place, Baulkham Hills NSW 2153. Toll Free: 1800 226 643
Subaru Australia reserves the right to vary vehicle specifications and standard features in Australia from those detailed in this brochure.
Vehicles shown in this brochure may be fitted with accessories available at additional cost.
No part of the brochure can be reproduced without written permission from Subaru Australia. Printed in Australia.
© Copyright 2010 – Subaru (Aust) Pty Limited. All rights reserved.

ALL 4
THE BACK ROADS
THE SHORT CUTS
THE ESCAPE ROUTES
THE PATH LESS
TRAVELLED
THE OUTBACK DRIVER



OUTBACK | 2011

ALL 4 THE DRIVER™



SUBARU

MY11 OUTBACK SPECIFICATIONS¹

MODEL		2.5i	2.5i Premium	2.5i Premium Satellite Navigation	3.6R	3.6R Premium Satellite Navigation	2.0D	2.0D Premium	2.0D Premium Satellite Navigation
TRANSMISSION									
6-speed manual transmission		•	•	•			•	•	•
Lineartronic™ CVT		•	•	•					
5-speed automatic transmission with manual mode					•	•			
ENGINE									
Engine type		Horizontally-opposed Boxer 4-cylinder, petrol engine			Horizontally-opposed Boxer 6-cylinder, petrol engine		Turbocharged horizontally-opposed Boxer 4-cylinder, diesel engine		
Valve mechanism		SOHC with i-AVLS			DOHC with Dual AVCS		DOHC		
Bore x stroke	mm	99.5 x 79.0			92 x 91		86 x 86		
Capacity	cc	2457			3630		1998		
Compression ratio		10			10.5		16		
Fuel tank capacity	litres				65				
Fuel system		Multi point sequential injection					Common rail direct injection		
Fuel requirement	RON	90-95					Diesel		
PERFORMANCE²									
Maximum power output (DIN)	kW/rpm	123kW@5600rpm			191kW@5600rpm		110kW@3600rpm		
Maximum torque (DIN)	Nm/rpm	229Nm@4000rpm			350Nm@4400rpm		350Nm@1800-2400rpm		
Acceleration 0 - 100 km/h	seconds	9.6 (MT)			7.6 (AT)		9.7 (MT)		
		10.4 (CVT)							
Electronic Throttle Control system (ETC)					Drive-by-wire				
Fuel consumption (ADR81/02) ³ - combined	l/100km	8.9 (MT) / 8.3 (CVT)			10.3		6.4		
	- urban	12 (MT) / 11.2 (CVT)			14.7		7.7		
	- extra urban	7.1 (MT) / 6.6 (CVT)			7.6		5.6		
CO ₂ emissions (ADR81/02) combined	(g/km)	209 (MT) / 193 (CVT)			242		168		
Emission standards		EURO4 (MT) / EURO5 (CVT)			EURO4		EURO5		
SYMMETRICAL ALL-WHEEL DRIVE									
Type	Manual	Centre Differential with a Viscous Limited Slip Differential			n/a		Centre Differential with a Viscous Limited Slip Differential		
Type	Auto	Active Torque Split			Variable Torque Distribution		n/a		
TRANSMISSION									
Gear ratio	1st	3.454 (MT) / 3.525 (CVT)			3.540		3.454		
	2nd	1.947 (MT) / Continuously Variable Transmission(CVT)			2.264		1.75		
	3rd	1.296 (MT) / Continuously Variable Transmission (CVT)			1.471		1.062		
	4th	0.972 (MT) / Continuously Variable Transmission (CVT)			1.000		0.785		
	5th	0.825 (MT) / Continuously Variable Transmission (CVT)			0.834		0.634		
	6th	0.695 (MT) / 0.558 (CVT)			n/a		0.557		
Gear ratio - reverse		3.636 (MT) / 2.358 (CVT)			2.370		3.636		
Final reduction gear ratio		4.444 (MT) / 3.9 (CVT)			3.083		4.444		
STEERING									
Steering		Engine speed sensitive power assisted rack and pinion					Electric power steering		
Minimum turning circle (kerb to kerb)	m						11		
SUSPENSION									
Type	Front	McPherson strut type, independent suspension							
Type	Rear	Self-levelling double wishbone type, independent suspension							
BRAKES									
Type	Front	Ventilated disc brake							
Type	Rear	Solid disc brake			Ventilated disc brake		Solid disc brake		
Brake booster type	mm	Tandem							
ABS		4-channel, 4-sensor ABS with Electronic Brakeforce Distribution							
WHEELS AND TYRES									
Tyre manufacturer		Yokohama							
Tyres (width, profile, size, load index & speed rating)		225/60 R17 99V							
Rim size		17x7JJ							
Wheels		17"							
Spare wheel		185/65 R17 90M "Temporary steel wheel"							
MEASUREMENT									
Overall length	mm						4790		
Overall width	mm						1820		
Overall height	mm						1615		
Wheel base	mm						2745		
Front track	mm						1535		
Rear track	mm						1535		
Minimum ground clearance ⁴	mm						213		
Cargo volume - rear seat up/down	litres						Wagon - 490 / 1690		
Tare mass	kg	1465 (MT) / 1505 (CVT)	1484 (MT) / 1524 (CVT)	1485 (MT) / 1525 (CVT)	1569	1600	1551	1571	1572
TOWING									
With trailer brakes/without trailer brakes	kg	1500/750			1800/750		1700/750		
Maximum tow ball down load	kg	150			180		170		

1. Subaru Australia reserves the right to change mechanical specification and equipment levels without notice. 2. All performance data measured using 95RON as required by Australian Design Rule 81/02. Vehicles tested in accordance with ADR 81/02. 3. Fuel consumption figures calculated in accordance with Australian Design Rules 81/02. 4. Ground clearance at kerb weight.

OUTBACK AWARDS

- 2009 • Fairfax Drive Car of the Year 2009, Best SUV under \$40,000 Subaru Outback
 - Australia's Best Cars, Best Recreational 4WD, Subaru Outback 2.5i
 - Australasian New Car Assessment Program (ANCAP) five-star occupant safety rating for the entire Outback range

subaru.com.au

Subaru (Aust) Pty Limited ABN 95 000 312 792 (Subaru Australia)
Level 3, 4 Burbank Place, Baulkham Hills NSW 2153. Toll Free: 1800 226 643

Subaru Australia reserves the right to vary vehicle specifications and standard features in Australia from those detailed in this brochure.

Vehicles shown in this brochure may be fitted with accessories available at additional cost.

No part of the brochure can be reproduced without written

permission from Subaru Australia. Printed in Australia.

© Copyright 2010 – Subaru (Aust) Pty Limited. All rights reserved.

